

EVINRUDE/JOHNSON PROPELLER SELECTION GUIDE



EVINRUDE
Johnson | 
GENUINE PARTS

EXPERIENCE MORE AT EVINRUDE.COM

TABLE OF CONTENTS

WHERE THE POWER MEETS THE WATER!	3
HOW DOES A PROPELLER WORK?	3
WHAT TO CONSIDER WHEN SHOPPING FOR A PROPELLER	4
DIAMETER	4
PITCH	4
RAKE	4
CUP	4
VENTILATION	4
CAVITATION	4
MATERIAL	5
BLADE COUNT	5
ROTATION	5
SELECT THE RIGHT PROPELLER FOR YOUR BOAT AND OUTBOARD	7
STEP ONE: PROPELLER STYLE	7
STEP TWO: PROPELLER SIZE	7
STEP THREE: ENGINE MOUNTING HEIGHT	7
THINGS TO REMEMBER	7
PROPELLER HUB SYSTEMS	8
HARDWARE CHART	8
PROPELLER FAMILY DESCRIPTIONS	9
REBEL	9
RAKER	9
RENEGADE BASS	9
CYCLONE	9
VIPER	9
ROGUE	9
SSP	9
HYDRUS	9
EVINRUDE/JOHNSON ALUMINUM PROPS	9
APPLICATION CHART	9
QUICK REFERENCE GUIDES	10



EXPERIENCE MORE AT EVINRUDE.COM

WHERE THE POWER MEETS THE WATER!

Choosing the right propeller is the single most important decision you can make to get the best performance from your boat and outboard! Propeller choice can affect boat top speed by as much as 5 to 10 MPH. It also has a direct effect on acceleration, cornering, pulling power, and fuel economy. With some boats, you may need to change propellers for different activities, such as high speed cruising, water skiing, or carrying heavy loads. Using the wrong propeller in any of these applications will not only hurt performance, but could also cause engine damage.



BASIC PROPELLER TERMS

- A** LEADING EDGE. The edge of the blade closest to the boat.
- B** TRAILING EDGE: The edge of the blade farthest from the boat.
- C** BLADE TIP: The point on the blade farthest from the hub. It separates the leading edge from the trailing edge.
- D** BLADE ROOT: The area where the blade attaches to the hub.
- E** BLADE BACK: The side of the blade closest to the boat (low pressure side).
- F** BLADE FACE: The side of the blade opposite to the boat (high pressure side).

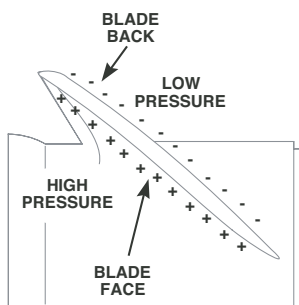
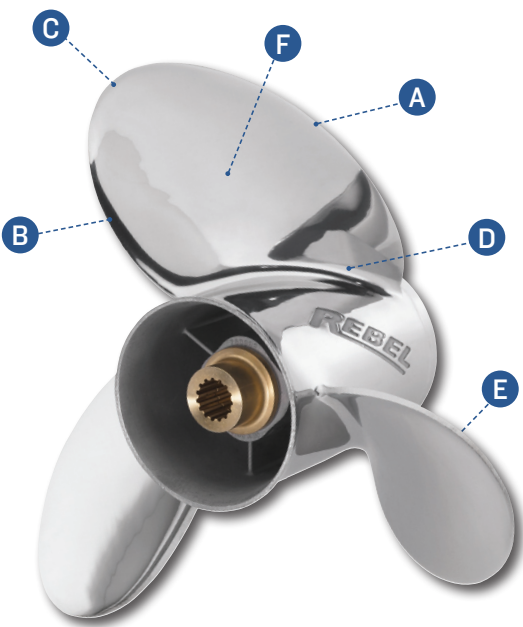

HOW DOES A PROPELLER WORK?

A propeller is a set of identical twisted blades, spaced evenly around a hub. Most propellers have a splined bushing in the hub that mounts on the outboard. The bushing attaches to the propeller with flexible rubber that acts like a shock absorber. If the propeller strikes something hard, the rubber helps protect against damage. Newer propellers may use a multi-piece interchangeable hub system. Refer to Propeller Hub systems on Page 9. Each propeller blade has two surfaces that displace water to move the boat. As the propeller rotates, the blade back creates a low pressure that helps pull the boat forward. The blade face creates high pressure as it rotates. This pressure forces a stream of water away from the propeller. As the water is pushed to the rear, an equal force pushes the boat forward.

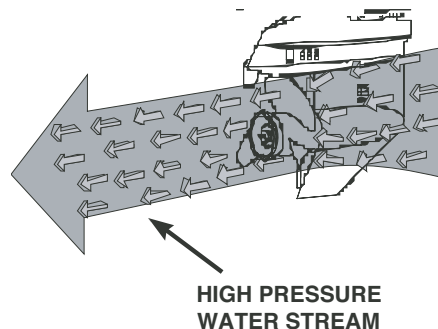

WHAT TO CONSIDER WHEN SHOPPING FOR A PROPELLER

WHAT TO CONSIDER WHEN SHOPPING FOR A PROPELLER

SEVERAL CHARACTERISTICS AFFECT HOW A PROPELLER WILL PERFORM. ESPECIALLY IMPORTANT ARE PROPELLER DIAMETER, PITCH, RAKE, AND CUP. MOST PROPELLERS ARE IDENTIFIED BY THEIR DIAMETER AND PITCH. LOOK FOR A NUMBER LIKE $14\frac{3}{4} \times 21$. THE FIRST NUMBER IS THE DIAMETER, THE SECOND IS THE PITCH. IN ADDITION, IT IS IMPORTANT TO UNDERSTAND THE EFFECTS OF VENTILATION, CAVITATION, MATERIALS, AND OTHER APPLICATION VARIABLES ON PROPELLER PERFORMANCE.

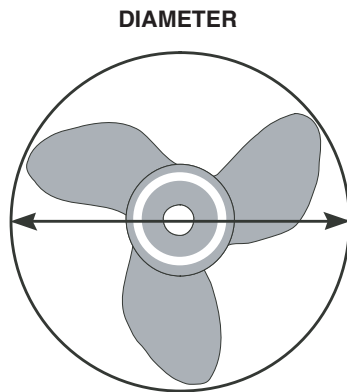

DIAMETER

Diameter is the width of the circle described by the tips of the rotating blades. Propeller diameter determines the amount of power a propeller can apply to the water—how much load the propeller can push. Generally, heavy loads require larger diameter propellers while small, fast boats are more efficient with a smaller diameter. However, diameter is not usually a critical option when choosing a propeller. Focus instead on propeller style and pitch.

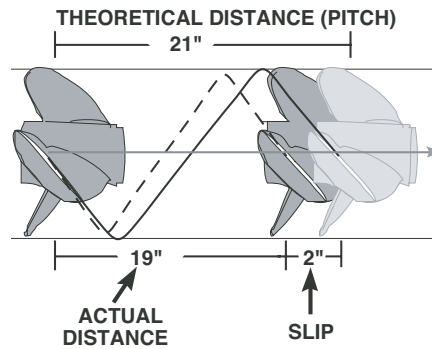

PITCH

Pitch is the theoretical distance a propeller will travel in one complete revolution. For example, a $14\frac{3}{4} \times 21$ propeller would ideally move 21 inches forward with each revolution. In practice, the actual distance travelled is less than the pitch because of "slip" which is necessary to produce thrust. Lower pitched propellers are like the lower gears on a car or bicycle. They create less forward travel with each revolution. A low pitch allows engine RPM to build up quickly, which gives faster acceleration and more pulling power. This works well for heavy loads, but results in slower top speeds. Higher pitched propellers are similar to high gears. They create more forward travel with each revolution. A high pitch puts more load on the engine, which reduces low speed pulling power and acceleration, but usually provides more top speed.

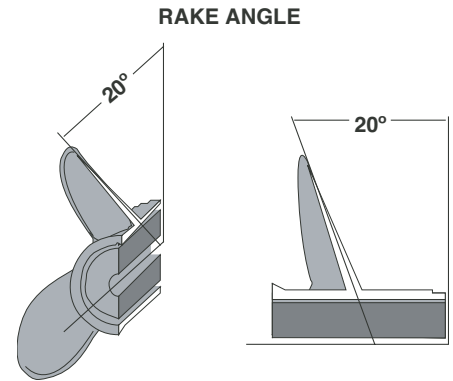

RAKE

Rake is the angle the blade tip tilts away from the gearcase. The angle is measured on a line extending from the center of the hub through the center of the blade. Rake can be either flat or progressive. Progressive rake means that the rake angle increases with distance from the hub. Most propellers have between 0° and 20° rake. High rake propellers tend to lift the bow of the boat. On fast, lightweight, V-bottom boats, a high rake propeller should increase speed by reducing the amount of wetted hull surface. When operated partially surfacing, high rake propellers reduce the amount of water being thrown off the blade by centrifugal force as the blade leaves the water. This allows high rake propellers to work more effectively in these applications. Tunnel boats and other air entrapment type hulls may become unstable when using a high rake propeller. In these applications, a propeller with less bow lift would be a more appropriate selection.



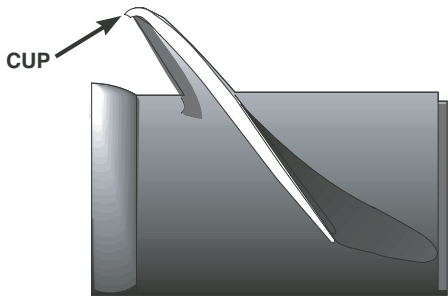

CUP

Cup is the small curved lip added to the edges of some propellers. Cupping acts like a seal on the edge of the blade. It keeps water on the high pressure blade face from flowing around the trailing edge to the low pressure area on the blade back. This reduces ventilation and slipping, especially when operating in disturbed or aerated water. Propellers with cup excel in sharp turns and applications where the engine is mounted higher than normal. Cupping also allows the outboard to be trimmed higher for more bow lift. Cupping the tips of the blades increases the effective rake, adding to the bow lift capabilities of the propeller. Adding cup to the trailing edge of the blades has the effect of increasing pitch. As a result, you can expect a slight loss of engine speed (150-300 RPM) when cup is added. However, the additional cup may allow the propeller to work at a higher transom height. Raising the motor will reduce drag on the gearcase and will often recover the engine speed.

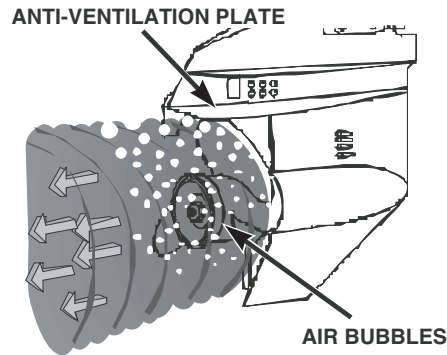
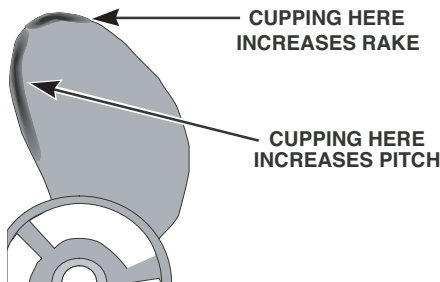

VENTILATION

Ventilation is the result of air bubbles from surface air or exhaust gases being drawn into the blades. These pockets of air make a propeller lose its bite or thrust. Your RPM may climb wildly, yet you may not gain or lose speed. This is most common with high transom mountings, extreme trim settings, or sharp turns. To help prevent ventilation, the outboard has an anti-ventilation plate directly above the propeller. For most applications, this plate should be within an inch above or below the bottom of the boat. On a high-performance boat, this rule does not necessarily apply. The anti-ventilation plate may be several inches above the boat bottom. Water testing is the best way to determine the correct engine mounting height. Cupped or high performance propellers help minimize ventilation.

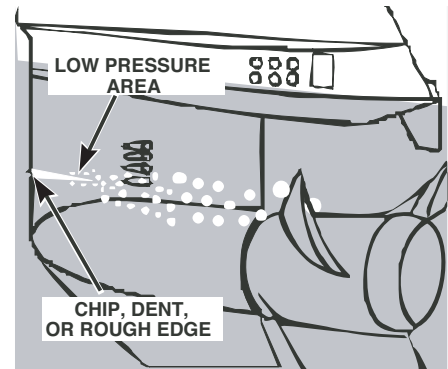

CAVITATION

Cavitation is caused by a disturbance of the water flow in front of the propeller. An irregularity in the boat bottom or gearcase, a misplaced transducer or speedometer pickup, or even a loose rivet can cause this problem. Cavitation begins when a disturbance creates a low-pressure area in the water flow. As speed increases, the low pressure intensifies enough to vaporize (boil) some of the surrounding water. When the vapor bubbles approach a high pressure area, they collapse, releasing energy and causing damage. The results of cavitation usually appear as burned areas on the gearcase or propeller blades. If the damage is substantial, performance is lost and the propeller should be replaced. In addition, the cause of the disturbance should be repaired to prevent further problems.

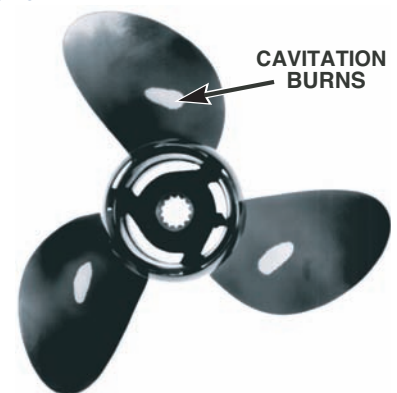



MATERIAL

Aluminum propellers provide a good balance of cost, performance, and durability for most applications.

Stainless steel propellers offer improved performance, fuel economy, and durability. Because stainless steel is five times stronger than aluminum, it is much less susceptible to damage from striking underwater objects. However, the main advantage of stainless steel is in performance. Because of its strength, stainless propeller blades can be cast much thinner, which reduces drag. Stainless steel blades are also stiffer, which increases efficiency. Composite and plastic propellers are generally used for emergency situations.

BLADE COUNT

Theoretically, the fewer number of blades a propeller has, the more efficient it will be. But as the number of blades is increased, vibration is decreased. For most applications, three blade propellers provide the best balance between efficiency and smoothness. However, BRP/Evinrude engineers have created a series of four blade propellers that provide increased efficiency and a superior grip on the water. The result is improved acceleration and better cornering in all water conditions. In addition, when operated in a surfacing application, a four blade propeller keeps more blades in the water for maximum thrust and efficiency.

ROTATION

Right-hand propellers are considered standard rotation propellers. To move the boat forward, the propeller rotates in a right-hand (clockwise) direction as viewed from the rear. Left-hand propellers are considered counter-rotation propellers. To move the boat forward, the propeller rotates in a left-hand (counterclockwise) direction as viewed from the rear. Left-hand propellers must **ONLY** be used on an outboard equipped with a counter-rotation gearcase. In a dual-outboard installation, the use of both right-hand and left-hand propellers balances the torque created by the rotation of the propellers. This helps to reduce the effort needed in steering and also helps to keep the boat level from side to side.

WARNING

For dual-outboard installations, always check to be sure propellers are installed on the correct engines before aggressively operating the boat.

SELECT THE RIGHT PROPELLER FOR YOUR BOAT AND OUTBOARD

STEP ONE

Choose the propeller type designed for the way the boat will be used:

- Fishing, skiing, cruising, commercial, racing, etc?
- How many people will be on board?
- Is the water shallow, or are there rocks or other underwater objects?
- Will the boat be used for multiple purposes?

Use the propeller family descriptions in the following pages as a guide. For example, a Rebel™ propeller could be a good choice for a large, offshore boat. In contrast, a Raker® propeller provides bow lift, for increased top speed, on small, fast boats.

STEP TWO

Find the correct sized propeller for your specific outboard, boat, and load combination. When selecting a propeller, start with the propeller charts in the following pages. These charts group all of the propellers designed for a particular outboard and provide detailed information such as pitch, diameter, style, and the number of blades.

To complete the selection process, you must perform a water test. During this running test, you will determine the best combination of engine mounting height, propeller style, and propeller pitch.

All Evinrude and Johnson outboards have a recommended full throttle operating range. This means that, at full throttle, engine RPM must never be below or above this range. These specifications can be found in the Operator's Guide.

The propeller provides the load that controls engine RPM. Reducing propeller pitch size will increase engine RPM at full throttle. Increasing propeller pitch size will decrease engine RPM at full throttle.

You have the correct propeller pitch when the engine runs at the midpoint of the full throttle operating RPM range with the normal, expected load in the boat. This is usually the point of peak horsepower. Choosing the correct propeller pitch for a given boat and application will ensure long engine life, along with best overall fuel economy and performance.

When you have a selection of propellers ready for testing:

1. Use an accurate tachometer to measure RPM and an accurate speedometer to measure boat speed.
2. Testing should be performed with the typical load—number of people, gear, water in live wells, etc.
3. Make sure that every test is with an identical setup.
4. Test each propeller at wide open throttle (WOT).
5. Engines should be tested at their optimum trim angle. This is the highest trim position the engine can be run without excessive ventilation, either in a straight line or in turns.
6. If the RPM is too low at WOT, try a reduced pitch and retest.
7. If the RPM is too high at WOT, test a propeller with more pitch. One pitch size usually results in a change of 200-300 RPM.
8. If the boat will be used for two applications, like water skiing and cruising, it may be necessary to test propellers for each type of use.

STEP THREE

Adjust the engine mounting height for peak performance. The ideal engine mounting height provides the fastest boat speed without sacrificing acceleration, maneuverability, or engine water pressure. It is achieved by a trial and error method.

1. Start with the outboard's anti-ventilation plate even with the bottom of the boat.
2. Raise the outboard one mounting hole at a time until engine performance is no longer acceptable. Then, lower the outboard back down one hole. Optimum engine height is affected by propeller style, diameter, and pitch. As you raise the engine, you may need to experiment with a variety of propellers to maximize performance.

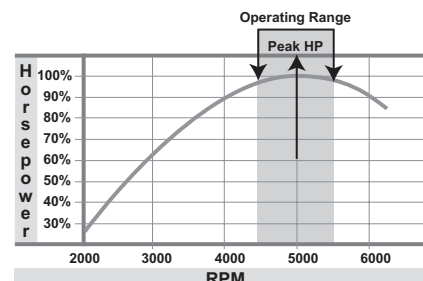

THINGS TO REMEMBER

Check full throttle RPM often. It is possible that the propeller pitch size may have to change as the boating application or load changes.

- Adding or removing people can significantly change the power requirements placed on the engine.
- Changes in atmospheric pressure, temperature, and humidity all affect engine performance, which directly affects propeller performance.
- Salt water is more buoyant than fresh water; this may cause some hulls to run faster when moving from a fresh water to salt water location.
- The accumulation of marine growth or dirt—moss, barnacles, lime deposits, etc—is a major cause of poor boat performance.

PROPELLER HUB SYSTEMS



DID YOU KNOW EVINRUDE JOHNSON GENUINE PARTS HAS PROPELLERS TO FIT EVERY BRAND OF OUTBOARD ENGINE?

Evinrude and Johnson has been a leader in propeller performance for over 40 years. Since 1982 our engineers have laid claim to defining new levels of speed and performance with the legendary Raker and now the Raker II propellers. Since the Nineties, the Viper propeller has unleashed previously unknown performance in the everyday runabout. As an extra bonus every Evinrude Johnson propeller comes with a 3 year limited warranty.

Evinrude Johnson Genuine Parts has been expanding our propeller line to include a select group of V4 and V6 propellers with interchangeable hub systems.

The Evinrude Johnson interchangeable hub offering begins with V4 and V6 aluminum propellers, commonly referenced in the aftermarket as D Series and E Series. They use the “Aluminum Interchangeable Hub” system and can be fitted with accessory hub kits designed to match the propeller

shaft of all brands of outboard engines.

The expanded lineup continues into the V6, E Series stainless steel propellers comprised of SSP, Viper, Rebel, Cyclone and Raker II propellers. These props use the TBX hub system designed specifically for the heavy load requirements of high horsepower outboards. With only one additional TBX hub kit these propellers can also be fitted to virtually every competitive brand of V6 outboard engine.

PROPELLER HUB SYSTEM - V6 STAINLESS STEEL PROPELLER INTERCHANGEABLE CHART

DESCRIPTION	P/N
TBX™ bushing kit (POP) - Evinrude®/Johnson® outboards V6	177283
TBX™ bushing kit (POP) - competitive outboards V6	177288

PROPELLER HUB SYSTEM - ALUMINUM PROPELLER INTERCHANGEABLE CHART

APPLICATION	SPLINE	YEAR	P/N
Evinrude®/Johnson® V4 45-75 HP, large gearcase 4-1/4"	13	1968-current	765195
Evinrude®/Johnson® V4 85-140 HP	13	1969-current	765195
Evinrude®/Johnson® 90-140 HP, large gearcase	15	1991-current	765190
Force® 75-150 HP	15	1995-current	765192
Honda® 75-150 HP	15	1995-1998	765192
Honda® BF 135 HP, 150 HP, 200 & 225 HP	15	2003-current	765192
Mercury®/Mariner®/MerCruiser® 60 HP Bigfoot	15		765192
Mercury®/Mariner®/MerCruiser® 70-140 HP (except 135 HP), XR-4, XR-6	15	1961-current	765192
Mercury®/Mariner®/MerCruiser® 135 HP	15	1987-current	765192
Mercury®/Mariner®/MerCruiser® 150-300 HP	15	1978-current	765192
Yamaha® 80-140 HP	15	1978-1983	765192
Yamaha® 150-175 HP	15	1978-1983	765192
Yamaha® 115 HP, FS115 (4-stroke), 130 HP	15	1984-current	765193
Yamaha® 150-130 HP	15	1984-current	765193
Yamaha® Sterndrives	15	1989-1993	765193
OMC Cobra® SX	19	1994-current	765194
Volvo® SX Sterndrives	19	1994-current	765194
Honda® 75-90 HP	15	1999-current	765196
Honda® 115-130 HP	15	1999-current	765196
Nissan®/Tohatsu® 90-140 HP	15	1987-current	765197
Mercury®/Mariner®/MerCruiser® 225 EFI (4-stroke) manufactured by Yamaha®	15		765198
Evinrude®/Johnson® 90, 115 HP (4-stroke)	15	2003-current	765199
Suzuki® DF90, DF115 (4-stroke)	15	2001-current	765199
Suzuki® DF140 (4-stroke)	15	2001-current	765200

FAMILY DESCRIPTIONS

THE RIGHT PROPELLER WILL INCREASE FUEL ECONOMY, TOP-END SPEED AND EVEN ENGINE LIFE. WE'VE ENGINEERED EVINRUDE JOHNSON PROPELLERS FOR EVERY APPLICATION. AND ALL OF OUR PROPS FEATURE A 3-YEAR LIMITED WARRANTY. THE BEST PROPELLERS ALL HAVE ONE THING IN COMMON: THE LEGENDARY EVINRUDE JOHNSON NAME.



RAKER® II TBX™
BASS & HIGH PERFORMANCE

- Fast, Fast, Fast...
- Custom cupped high rake blades
- Superior bow lift
- Exceptional top end speed
- Vented hub for faster acceleration
- V6 Raker II use the TBX hub system



CYCLONE™ TBX™
OFFSHORE CRUISING & RUNABOUTS

- V6 – Standard & Counter Rotation
- Enhanced performance propeller
- Stays on plane with minimum RPM
- Less vibration and improved fuel economy
- TBX interchangeable hub system



REBEL® TBX™
OFFSHORE & CRUISING

- V6 – Standard & Counter Rotation
- Use on offshore boats, large runabout, & pontoon boats
- Designed & engineered for efficient midrange cruising
- Improved fuel economy with longer cruising range
- TBX interchangeable hub system



VIPER™ TBX™
RUNABOUTS & GENERAL RECREATION

- V6 – Standard & Counter Rotation
- V4 – Standard Rotation
- Versatile 3-blade performance
- Excellent balance of speed and durability
- V6 sizes use the TBX™ hub system
- 40HP-130HP w/shock absorbing rubber hub



SSP® TBX™
GENERAL PURPOSE & DURABILITY

- Ideal upgrade from aluminum
- Fast planing 3-blade versatile prop
- Cupped blades
- V6 sizes use the TBX™ hub system
- 40HP-130HP w/shock absorbing rubber hub



ROGUE™
SMALL RUNABOUTS & FLATS BOATS

- Provides extra stern lift
- Stays on plane with minimum RPM
- Custom high luster finish
- 40HP-130HP w/shock absorbing rubber hub



HYDRUS™ PONTOON
PONTOON BOATS

- Ideal upgrade from aluminum
- Fast planing 3-blade versatile prop
- Cupped blades
- V6 sizes use the TBX™ hub system
- 40HP-130HP w/shock absorbing rubber hub



ALUMINUM
GENERAL PURPOSE & ECONOMY

- Sizes for 40HP through 300HP
- Lowest cost and good value
- Precision casting provides great strength and long life
- Cupped blades
- Includes custom interchangeable hub system

FAMILY APPLICATION CHART

ENGINE TYPE	ALUMINUM	HYDRUS	SSP	ROGUE	RAKER	VIPER	REBEL	CYCLONE
I2 40-60 HP	•	•	•	•	•	•		
I3 75-90 HP*	•	•	•	•	•	•		
V4 I15-130 HP	•	•	•	•	•	•		
V6 I50-300 HP	•		•		•	•	•	•
Rotation - Standard RH	•	•	•	•	•	•	•	•
Rotation - Counter LH			•			•	•	•

BOAT TYPE	ALUMINUM	HYDRUS	SSP	ROGUE	RAKER	VIPER	REBEL	CYCLONE
Runabout - Fiberglass	•		•	•		•		•
Runabout - Aluminum	•		•	•		•		•
Deck Boat	•					•	•	•
Flats Boat	•			•		•		•
Bay Boat	•			•		•	•	•
Multi-Species Boat - Aluminum	•					•		•
Multi-Species Boat - Fiberglass					•	•	•	
Bass Boat					•			•
Sport Runabout I50 HP+					•			
Offshore - small, single engine	•			•		•	•	•
Offshore - multiple engine						•		•
Pontoon - twin log	•	•	•	•		•	•	
Pontoon - triple log						•	•	

QUICK REFERENCE GUIDE

ALL ALUMINUM PROPELLERS FITTING 40-140HP 2-STROKE, 13 SPLINE AND V6 ALUMINUM PROPELLERS, 15 SPLINE ARE PACKAGED WITH ALUMINUM INTERCHANGEABLE HUB KIT. ALL V6 STAINLESS STEEL PROPELLERS ARE PACKAGED WITH THE EVINRUDE / JOHNSON TBX HUB KIT. REFER TO THE INTERCHANGEABLE HUB KIT CHART TO ORDER KITS TO FIT COMPETITORS OUTBOARDS.

ALL EVINRUDE®/JOHNSON® PROPELLERS HAVE A 3-YEAR LIMITED WARRANTY!

15H.O.-30 HP EVINRUDE® E-TEC®

P/N	MATERIAL/FAMILY	BLADE COUNT	DIAMETER	PITCH	NOTES
5008225	Aluminum	4	11"	7"	15H.O. High Thrust
765048	Aluminum	3	11"	9"	General Purpose and Economy
765049	Aluminum	3	10 1/2"	11"	General Purpose and Economy
765135	Aluminum	4	10.2"	11"	General Purpose and Economy
765050	Aluminum	3	10.3"	12"	General Purpose and Economy
765136	Aluminum	4	10.1"	12"	General Purpose and Economy
778863	Aluminum	3	10.3"	13"	General Purpose and Economy
765137	Aluminum	4	10"	13"	General Purpose and Economy
765138	Aluminum	4	10"	14"	General Purpose and Economy
763486	Aluminum	3	10"	15"	General Purpose and Economy
765139	Aluminum	4	10"	15"	General Purpose and Economy
765176	SSP	3	10"	11"	Durability and General Purpose
765174	SSP	4	10"	11"	Durability and General Purpose
765177	SSP	3	10"	12"	Durability and General Purpose
765175	SSP	4	10"	12"	Durability and General Purpose
765178	SSP	3	10"	13"	Durability and General Purpose
766153	SSP	4	10"	13"	Durability and General Purpose
765179	SSP	3	10"	14"	Durability and General Purpose
765180	SSP	3	10"	15"	Durability and General Purpose

40-130 HP EVINRUDE® E-TEC® (EXCLUDES 25" MODELS)

P/N	MATERIAL/FAMILY	BLADE COUNT	DIAMETER	PITCH	NOTES
763300	Aluminum	3	14"	9"	General Purpose and Economy
763301	Aluminum	3	14"	11"	General Purpose and Economy
765181	Aluminum	3	13 3/4"	13"	General Purpose and Economy
765182	Aluminum	3	13 1/2"	15"	General Purpose and Economy
765183	Aluminum	3	13 1/4"	17"	General Purpose and Economy
765184	Aluminum	3	13.2"	19"	General Purpose and Economy
765185	Aluminum	3	13.2"	21"	General Purpose and Economy
I77201	Hydrus™ Aluminum	3	13 7/8"	9"	Pontoon boats, High Reverse Thrust
I77202	Hydrus™ Aluminum	3	13 7/8"	11"	Pontoon boats, High Reverse Thrust
I77203	Hydrus™ Aluminum	3	13 7/8"	13"	Pontoon boats, High Reverse Thrust
763957	SSP	3	13 3/4"	13"	Durability and General PurposE
763950	SSP	3	13 1/2"	15"	Durability and General PurposE
763951	SSP	3	13 1/4"	17"	Durability and General PurposE
763952	SSP	3	13"	19"	Durability and General PurposE
763929	Viper™	3	13 7/8"	15"	Swept blade design, General use, Bow Lifter
763930	Viper™	3	13 7/8"	17"	Swept blade design, General use, Bow Lifter
763931	Viper™	3	13 7/8"	19"	Swept blade design, General use, Bow Lifter
763932	Viper™	3	13 7/8"	21"	Swept blade design, General use, Bow Lifter
763953	Raker®	3	13 1/2"	18"	High Performance Bow Lifter
763954	Raker®	3	13 1/2"	20"	High Performance Bow Lifter
763956	Raker®	3	13 1/2"	24"	High Performance Bow Lifter
763964	Rogue™	4	13 1/2"	13"	Flat Boats and Runabouts
763965	Rogue™	4	13 1/4"	15"	Flat Boats and Runabouts
763966	Rogue™	4	13"	17"	Flat Boats and Runabouts
763967	Rogue™	4	13"	19"	Flat Boats and Runabouts
763968	Rogue™	4	13"	21"	Flat Boats and Runabouts

QUICK REFERENCE GUIDE

150 - 300 HP EVINRUDE® E-TEC®, 25" MODELS - 90, 115, 130 EVINRUDE® E-TEC®

RIGHT HAND (STANDARD ROTATION)	LEFT HAND (COUNTER ROTATION)	MATERIAL/ FAMILY	BLADE COUNT	DIAMETER	PITCH	NOTES
763453		Aluminum	3	15 1/2"	13"	General Purpose and Economy
765186		Aluminum	3	15"	15"	General Purpose and Economy
765187		Aluminum	3	14 7/8"	17"	General Purpose and Economy
765188		Aluminum	3	14 1/2"	19"	General Purpose and Economy
765189		Aluminum	3	14.3"	21"	General Purpose and Economy
763470		Aluminum	3	14 1/4"	23"	General Purpose and Economy
763959		SSP TBX™	3	15 5/8"	11"	Durability and General Purpose
763960	763961	SSP TBX™	3	15 5/8"	13"	Durability and General Purpose
763962	763963	SSP TBX™	3	15"	15"	Durability and General Purpose
763910	763911	Viper™ TBX™	3	15"	14"	All-around General Purpose, Bow Lifter
763912	763913	Viper™ TBX™	3	14 3/4"	16"	All-around General Purpose, Bow Lifter
763914	763915	Viper™ TBX™	3	14 3/4"	17"	All-around General Purpose, Bow Lifter
763916	763917	Viper™ TBX™	3	14 3/4"	18"	All-around General Purpose, Bow Lifter
763918	763919	Viper™ TBX™	3	14 3/4"	19"	All-around General Purpose, Bow Lifter
763920	763921	Viper™ TBX™	3	14 3/4"	20"	All-around General Purpose, Bow Lifter
763922	763923	Viper™ TBX™	3	14 1/2"	21"	All-around General Purpose, Bow Lifter
763924	763925	Viper™ TBX™	3	14 1/4"	22"	All-around General Purpose, Bow Lifter
763936	763937	Cyclone™ TBX™	4	14 1/2"	15"	Cruising and Transom Lift
763938	763939	Cyclone™ TBX™	4	14 1/4"	17"	Cruising and Transom Lift
763940	763941	Cyclone™ TBX™	4	14 1/8"	18"	Cruising and Transom Lift
763942	763943	Cyclone™ TBX™	4	14 1/8"	19"	Cruising and Transom Lift
763944	763945	Cyclone™ TBX™	4	14"	20"	Cruising and Transom Lift
763946	763947	Cyclone™ TBX™	4	14"	21"	Cruising and Transom Lift
763948	763949	Cyclone™ TBX™	4	14"	23"	Cruising and Transom Lift
177264		Raker II® TBX™	3	14 1/2"	22"	High Performance Bow Lifter
177265		Raker II® TBX™	3	4 1/2"	24"	High Performance Bow Lifter
177309		Raker II® TBX™	3	14 1/2"	24"	High Performance Bow Lifter
(Big Bass - special vent holes)						
177299		Raker II® TBX™	3	14 1/2"	25"	High Performance Bow Lifter
177266		Raker II® TBX™	3	14 1/2"	26"	High Performance Bow Lifter
177267		Raker II® TBX™	3	14 1/2"	28"	High Performance Bow Lifter
763984	763985	Rebel TBX™	3	15 3/4"	15"	Faster Cruising Speeds and Improved Fuel Economy
763986	763987	Rebel TBX™	3	15 1/2"	17"	Faster Cruising Speeds and Improved Fuel Economy
763988	763989	Rebel TBX™	3	15 3/8"	18"	Faster Cruising Speeds and Improved Fuel Economy
763990	763991	Rebel TBX™	3	15 1/4"	19"	Faster Cruising Speeds and Improved Fuel Economy
763992	763993	Rebel TBX™	3	15 1/8"	20"	Faster Cruising Speeds and Improved Fuel Economy
763994	763995	Rebel TBX™	3	15"	21"	Faster Cruising Speeds and Improved Fuel Economy
763996	763997	Rebel TBX™	3	14 7/8"	22"	Faster Cruising Speeds and Improved Fuel Economy
763998	763999	Rebel TBX™	3	14 3/4"	23"	Faster Cruising Speeds and Improved Fuel Economy
764000	764001	Rebel TBX™	3	14 1/2"	25"	Faster Cruising Speeds and Improved Fuel Economy
763933		Renegade™ Bass	4	13 1/2"	23"	Bass and High Performance





THE WORLD IS OUR PLAYGROUND

Nothing is more valuable than your playtime. That is why BRP is dedicated to continually finding new and better ways to help you enjoy your favorite powersports. From snow to water to both on-and-off road fun, our passion for adventure fuels the innovations that result in the ultimate powersports experience for our customers. We value

the land and water we play on and are committed to protecting it. Our desire to thrill is paired with an emphasis on rider responsibility, placing personal safety above all else. So that each outing can be the most enjoyable, memorable and thrilling experience possible. Because your free time should always be your best time.



www.brp.com



SKI-DOO® SEA-DOO® CAN-AM®
LYNX® EVINRUDE® JOHNSON® ROTAX®