

# 4000 Series

Compact Utility Tractors





# Settle in for the long haul.

When it comes to comfort and performance, John Deere 4000 TWENTY Series Tractors stay ahead of the game with premium features and an efficient design. Take the adjustable, ergonomic driver's seat, for instance. Or pedals that reduce stress on your legs and ankles. When you add features like the Economy PTO for extra fuel savings and the exclusive Performance Tracking System for at-a-glance system monitoring, you've got a tractor that combines advanced technology with superior comfort.



- 1 LoadMatch™ electronic power management system** maximizes torque and virtually eliminates the possibility of stalling.
- 2 Quik-Park™ loaders** can be attached and detached in minutes—without tools. Mechanical self-leveling loader ensures full buckets everytime when loading.
- 3 Standard 4WD** digs in when doing loader work or rotary cutting over challenging ground.
- 4 Available eHydro™ hydrostatic transmission** makes it easy to switch from forward to reverse, plus lets you rest your heel on the platform.
- 5 An exclusive digital Performance Tracking System** instantly tells you the status of the vital systems on your tractor.
- 6 Economy PTO** runs at a lower rpm, providing fuel efficiency without compromising power or capacity (4520/4720).
- 7 Up to 5 hydraulic SCVs** provides expanded versatility when using multiple hydraulic implements.







## STANDARD FEATURES AND OPTIONS

### Transmission

**eHydro™**  
Effortless two-pedal automatic transmission. With easy shifting from forward to reverse at the touch of a pedal, it's ideal for everything from loading to mowing. And with **eThrottle™** on 4520 and 4720, a turn of a switch allows the tractor to operate like a car, by linking engine and transmission together.

### PowrReverser™

Convenient dash-mounted lever makes this manual transmission easy to shift from forward to reverse without clutching—a noticeable benefit when loading.

### Tire options

**Bar Tread/R1**  
Provides the best traction, not as gentle on turf.

**Turf Tires/R3**  
Less aggressive tread is perfect for mowing and landscape work.

**Turf Special/R3**  
Specialty high-flotation tires typically used on fine turf like golf courses.

**Industrial/R4**  
Excellent traction and is softer on the grass than R1s. Often the preferred choice.

### Other Options

- Electro-hydraulic 3rd SCV
- Electro-hydraulic 4th/5th SCVs (cab only)
- Mechanical 4th/5th SCVs (open station)
- Electric diverter/2 add'l rear hydraulic couplers
- Air ride seat
- Automotive-style cruise control (eHydro only)
- Canopy
- Mid PTO
- Power beyond hydraulics
- Sunshade umbrella
- Seat armrests
- Top-and-tilt kit for 3-pt. hitch
- Vertical exhaust
- Economy PTO (optional on 4520 and 4720)

## DIMENSIONS

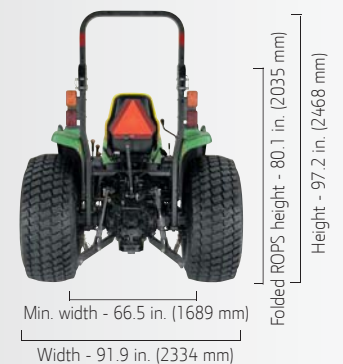



# All-around comfort.

Don't mind the weather. Despite rain, snow or sweltering sun, you'll be comfortable in a John Deere 4000 TWENTY Series cab. Tightly sealed to practically eliminate dust and allergens, designed to maximize visibility, and pressurized to boost air quality, the 4000 TWENTY Series cabs keep you focused on the task at hand—not Mother Nature. With features that include a parking brake, stereo and transmission control, it's as smooth and easy as driving a car. Plus, the Rollover Protection Structure and other safety features ensure these tractors are as safe as they are comfortable.





1

**Visibility:**

Unique raised header bar and high seat placement enable 360-degree views for safer maneuvering.

2

**Climate control:**

Roof-mounted system offers 15,000 BTUs of cooling and 30,000 BTUs of heating for year-round comfort.

3

**Allergen protection:**

ComfortGard™ cab keeps out dust and clippings—as well as microscopic allergens.

4

**Right-hand control center:**

Levers and controls are within easy reach for more efficient operating.

5

**Automotive features:**

Just like a car, the John Deere 4000 TWENTY Series Tractors provide optional features to keep you comfortable.

- Cup holder
- Arm rest
- 2-speed windshield wiper
- Sun visor
- Stereo with iPod™ dock
- Automotive cruise control (set, resume, accelerate, decelerate)
- Automotive-style hand parking brake



**A High-performance heating**

With a 15,000 BTU heater, you can stay comfortable even in the worst winter conditions while removing snow and ice from roads, driveways, paths and more.

**B High-performance cooling**

Extra large condensers and blowers mean fast, efficient cooling in the summer heat when mowing roadsides, cutting hay or doing loader work.

**C Completely pressurized**

Unlike competitors, John Deere ComfortGard Cabs are sealed and pressurized to keep cool air inside and dust and allergens where they belong: Outside.

**D True commercial-grade backhoes mount and dismount easily.**

Bucket rotation of 180 degrees is perfect for trenching without leaving behind spillage. Includes the exclusive and time-saving creep-to-reposition feature which allows vehicle movement from the backhoe operator seat position.



Stereo with iPod™ dock



Rear work lights



Deluxe air ride seat



Right-hand control center

**STANDARD FEATURES AND OPTIONS**

Standard cab features

- Air conditioning and heat
- Forward work lights
- Front windshield wiper
- Deluxe cloth seat
- Sun visor
- Right-hand control center
- Exclusive raised header bar
- Available R1, R3, R3 fine turf, R4 tires

Other options

- Deluxe air ride seat
- Dual external rearview mirrors
- Stereo with iPod™ dock
- Cab speaker kit
- Beacon light
- Back up alarm
- Front fender kit
- Rear fender extension kit
- Rear work light kit
- Electro-hydraulic 3rd SCV
- Electro-hydraulic 4th/5th SCVs

4



## Quality and power come standard.

They're quick, compact—and anything but basic. The John Deere 4005 and 4105 Compact Utility Tractors are built for hard work without the hassle, especially when it comes to loading, mowing and backhoe work. You'll experience reliable gear transmission and easy shifting from forward to reverse with the 4005, or standard hydrostatic transmission with no clutching or shifting with the 4105. Plus, the 4105 gives you Twin Touch™ pedals, 4WD and power steering.





- 1 **40.5 and 41.5 HP—Yanmar Liquid-Cooled Diesel Engine.** Efficient diesel engines that offer deep reserves of torque for handling tough loads.
- 2 **Fixed Roll Over Protective Structure—**certified to ASAE standards.
- 3 Optional **iMatch™ Quick Hitch** makes lining up and attaching rear implements a snap.
- 4 **Quik-Park™ 300 CX Loader** can be attached and detached in less than three minutes with no tools and never leaving the seat.
- 5 **Effortless power steering** even during loader operation.
- 6 **4WD and differential lock** dig in during loader work or traveling over challenging ground (optional on 4005 model).
- 7 **New cruise control** provides effortless, automotive-like control while reducing operator fatigue and increasing productivity. (4105)
- 8 **Electro-hydraulic SCV** makes grapple work effortless. (4105)



### 4005 Compact Utility Tractors

Reliable gear transmission with 9 forward and 3 reverse speeds, plus straight line shuttles for quickly shifting from forward to reverse.

### 4105 Compact Utility Tractors

Standard with hydrostatic transmission, no clutching or shifting, changes direction on a dime, perfect for loader, mowing and backhoe work.

## 4005 & 4105 DIMENSIONS

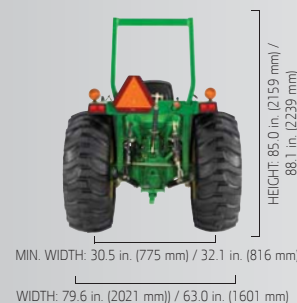



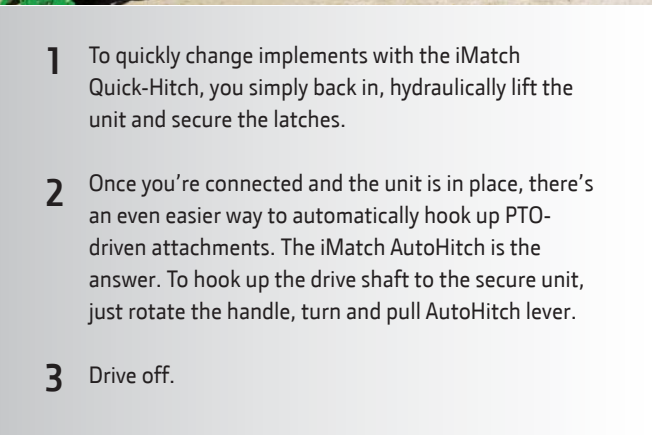

- 1 To quickly change implements with the iMatch Quick-Hitch, you simply back in, hydraulically lift the unit and secure the latches.
- 2 Once you're connected and the unit is in place, there's an even easier way to automatically hook up PTO-driven attachments. The iMatch AutoHitch is the answer. To hook up the drive shaft to the secure unit, just rotate the handle, turn and pull AutoHitch lever.
- 3 Drive off.





# OVER 200 ATTACHMENTS

## Pick up and go.

More than 200 attachments are ready and waiting for you to give them a spin. From backhoes to wheel rakes and every task in between, John Deere commercial-grade attachments not only do it all, they do it better and sooner. The time between starting up your tractor and getting work done is considerably shorter, thanks to John Deere iMatch™ AutoHitch™, Quik-Park™ loaders.

### ATTACHMENTS

	4005	4105	4120	4320	4520	4720
BACKHOES	•	•	•	•	•	•
BOX BLADES	•	•	•	•	•	•
CORE AERATOR	•	•	•	•	•	•
DISK HARROW	•	•	•	•	•	•
FLAIL MOWERS	•	•	•	•	•	•
FOOD PLOT SEEDER	•	•	•	•	•	•
GROOMING MOWERS	•	•	•	•	•	•
GROOMING MOWERS, REAR DISCHARGE	•	•	•	•	•	•
iMATCH AUTOHITCH			•	•	•	•
LANDSCAPE RAKES	•	•	•	•	•	•
LOADERS	•	•	•	•	•	•
MANURE SPREADERS	•	•	•	•	•	•
MID-MOUNT MOWERS			•	•	•	•
OVERSEEDERS	•	•	•	•	•	•
PENDULAR SPREADERS	•	•	•	•	•	•
POSTHOLE DIGGERS BY ROTOMEC	•	•	•	•	•	•
PULVERIZERS	•	•	•	•	•	•
REAR BLADES	•	•	•	•	•	•
ROTARY CUTTERS	•	•	•	•	•	•
ROTARY TILLERS	•	•	•	•	•	•
SICKLEBAR MOWERS	•	•	•	•	•	•
WHEEL RAKES	•	•	•	•	•	•



- 1 Quik-Park™ Loaders**—Fast cycle times, self leveling (400CX only), and impressive lift capacity for superior loading performance. Save time loading and save time putting them on and taking them off—a mere three minutes or less.
- 2 Tiller**—Commercial-duty with heavy-duty tubular tine shafts for excellent performance and durability even in packed-down soil conditions.
- 3 Rotary Cutters**—Designed to cut wide areas fast and those hard-to-reach areas easier.
- 4 Box Blades**—Take down mountains of work or just smooth out those molehills. Precision grading options available for standard duty, mid duty or construction grade.
- 5 Overseeder**—These 3-pt. hitch-compatible units quickly lay down new lawns with aggressive aerating action, precision-metered seed cups and large hopper capacities.
- 6 Food Plot Seeder**—Save time and fuel with single piece of equipment that can disc, plow, furrow, deposit seed, pack soil, cover seed and smooth soil in one pass. Custom-designed electronic drop seeder plants virtually any seed.
- 7 Backhoes**—Powerful digging and backfilling action along with excellent visibility to the trench. Includes the exclusive and time-saving creep-to-reposition feature which allows vehicle movement from the backhoe operator seat position. Available for cab and open-station models.





# Specifications

	4005	4105
<b>ENGINE</b>		
Type	Yanmar 4-cylinder diesel	Yanmar 3-cylinder diesel
HP*	41.5 (30.5 kW)	40.5 (29.8 kW)
PTO HP	35 (26.1 kW)	32.5 (24.2 kW)
Engine Displacement	121.7 cu. in. (2.0 L)	91.5 cu. in. (1.5 L)
<b>ELECTRICAL</b>		
Battery Capacity	650 CCA	500 CCA
Alternator	20 amps	40 amps
<b>HYDRAULICS</b>		
Steering	4.5 gpm (17.0 L/min.)	5.7 gpm (21.6 L/min.)
Implement	8.5 gpm (32.2 L/min.)	9.2 gpm (34.7 L/min.)
Total Capacity	13 gpm (49.2 L/min.)	14.8 gpm (56.2 L/min.)
Lift Capacity (24 in. Behind Link Arms)	2,020 lb. (916.3 kg)	2,200 lb. (999 kg)
<b>TRANSMISSION</b>		
Standard Transmission	Collar shift 9F/3R	Hydrostatic
Final Drive	Planetary	Spur gear
Brakes	Wet disk	Wet disk
Steering	Power	Power
Clutch	2-stage dry	Wet disk
4WD	Optional	Standard
<b>PTO</b>		
PTO Type	Continuous live	Independent
PTO Location	Rear standard	Rear standard
<b>REAR HITCH</b>		
Type	Category 1	Category 1
Control Type	Position	Position
<b>Weight</b>		
With All Fluids	2WD 2,954 lb. (1340 kg)	N/A
	4WD 3,175 lb. (1440 kg)	4WD 2,987 lb. (1355 kg)
<b>TIRE OPTIONS</b>		
	Bar Tread/R1, Turf Tire/R3	Bar Tread/R1, Industrial/R4
<b>ROLL OVER PROTECTIVE STRUCTURE</b>		
	Fixed	Fixed
300 CX Loader	1256 lb. (571 kg)	1393 lb. (633 kg)
Lift Capacity at full height, Measured at pivot		

No one builds or backs tractors better than John Deere.

It's the fine print, but a big story:

Every John Deere Compact Tractor comes with a 3-year/2000-hour limited warranty.\*\*\*

See your dealer for details.

**3 YEARS 2000 HOURS**  
LIMITED WARRANTY

\* Manufacturer's estimate of power (ISO) per 97/68/EC. \*\* eHydro

\*\*\* See the LIMITED WARRANTY FOR NEW JOHN DEERE COMMERCIAL AND CONSUMER EQUIPMENT for details.



## 4120

## 4320

## 4520

## 4720

ENGINE	John Deere PowerTech™	John Deere PowerTech™	John Deere PowerTech™	John Deere PowerTech™
Type	4-cylinder turbocharged diesel	4-cylinder turbocharged diesel	4-cylinder turbocharged diesel	4-cylinder turbocharged diesel
HP*	43 (31.6 kW)	48 (35.3 kW)	60 (44.1 kW)	66 (48.5 kW)
PTO HP	35/37 (26.1/27.6 kW)	39.9 (29.8 kW)	50/52 (37.3/38.8 kW)	56 (41.8 kW)
Engine Displacement	148.9 cu. in. (2.44 L)	148.9 cu. in. (2.44 L)	148.9 cu. in. (2.44 L)	148.9 cu. in. (2.44 L)
ELECTRICAL				
Battery Power	700CCA	700CCA	700CCA	700CCA
Alternator	70 A	70 A	70 A	70 A
HYDRAULICS				
Steering	5.1 gpm (19.3 L/min)	5.1 gpm (19.3 L/min)	5.1 gpm (19.3 L/min)	5.1 gpm (19.3 L/min)
Implement	12 gpm (45.3 L/min)	12 gpm (45.3 L/min)	12 gpm (45.3 L/min)	12 gpm (45.3 L/min)
Total Capacity	17.1 gpm (64.6 L/min)	17.1 gpm (64.6 L/min)	17.1 gpm (64.6 L/min)	17.1 gpm (64.6 L/min)
Lift Capacity (24 in. Behind Link Arms)	2,500 lb. (1134 kg)	2,500 lb. (1134 kg)	2,500 lb. (1134 kg)	2,500 lb. (1134 kg)
TRANSMISSION				
Standard Transmission	PowrReverser™ (12 Forward/12 Reverse gears)	PowrReverser™ (12 Forward/12 Reverse gears)	PowrReverser™ (12 Forward/12 Reverse gears)	eHydro™
Optional Transmission	eHydro™	eHydro™	eHydro™	N/A
Final Drive	Planetary	Planetary	Planetary	Planetary
Brakes	Wet disk	Wet disk	Wet disk	Wet disk
Steering	Power	Power	Power	Power
Clutch	Wet disk, PowrReverser™	Wet disk, PowrReverser™	Wet disk, PowrReverser™	N/A
4WD	Standard	Standard	Standard	Standard
PTO				
PTO Type	Independent	Independent	Independent	Independent
PTO Locations	Rear standard, mid optional	Rear standard, mid optional	Rear standard, mid optional	Rear standard, mid optional
Economy PTO	N/A	N/A	Optional	Optional
REAR HITCH				
Type	Category 1	Category 1	Category 1	Category 1
Control Type	Position	Position	Position	Position
WEIGHT (OPEN STATION)				
With All Fluids	3,700 lb. (1679 kg)	3,700 lb. (1679 kg)	3,700 lb. (1679 kg)	3,700 lb. (1679 kg)
TIRE OPTIONS				
	Bar Tread/R1, Turf Tire/R3, Turf Special/R3, Industrial/R4	Bar Tread/R1, Turf Tire/R3, Turf Special/R3, Industrial/R4	Bar Tread/R1, Turf Tire/R3, Turf Special/R3, Industrial/R4	Bar Tread/R1, Turf Tire/R3, Turf Special/R3, Industrial/R4
ROLL OVER PROTECTIVE STRUCTURE				
	Folding	Folding	Folding	Folding
COMFORTGARD™ CAB				
	N/A	Optional	Optional	Optional
AIR RIDE SEAT				
	Optional	Optional	Optional	Optional
CRUISE CONTROL				
	Standard	Standard	Standard	Standard
LOADMATCH™				
	Standard	Standard	Standard	Standard
AUTO CRUISE / MOTIONMATCH™				
	Optional	Optional	Optional	Optional
400 CX LOADER				
	2194 lb. (977 kg)	2194 lb. (977 kg)	2194 lb. (977 kg)	2194 lb. (977 kg)
Lift capacity at full height, measured at pivot				





## Total support is standard equipment.

No one can duplicate the support and knowledge of your local John Deere dealer. From the moment you enter a John Deere dealership, you can be sure you're getting the very best in customer assistance. Plus, John Deere dealers are in touch with your local community and understand what it takes to maintain your land. Factory-trained service and parts professionals keep your equipment working as hard as you do. Whether in the John Deere dealership or in the field, you can get your equipment serviced and move on to the next task.

### Optional John Deere Maintenance Plan Plus

Peace of mind can be financed for just a few dollars a month with the purchase of your tractor. The John Deere Maintenance Plan Plus includes two at home annual maintenance services with genuine John Deere parts. And an additional year of extended service protection, the same type of coverage as your original warranty.

### Exceptional Parts Support

Behind every John Deere is a parts support network to get you the high-quality part you need fast. If your dealer does not have a part in stock, in most cases you can order it by 5 p.m., and have it the next day. Or, order parts online at [www.JDParts.JohnDeere.com](http://www.JDParts.JohnDeere.com).

### Flexible Available Financing

John Deere Credit has convenient and flexible financing options designed for you. See your dealer for details.



This literature has been compiled for worldwide circulation. While general information, pictures and descriptions are provided, some illustrations and text may include finance, credit, insurance, product options and accessories NOT AVAILABLE in all regions. PLEASE CONTACT YOUR LOCAL DEALER FOR DETAILS. John Deere reserves the right to change specification, design and price of the products described in this literature without notice. John Deere's green and yellow color scheme, the leaping deer symbol, and JOHN DEERE are trademarks of Deere & Company.