



**YANMAR**

# ViO17-1E

TRUE ZERO TAIL SWING MINI EXCAVATOR



## Work in tight work sites with ease.

YANMAR's ViO17-1E, our 1.8-ton class mini excavator, is powered by a 14.5 HP Tier 4 Final YANMAR engine. It goes almost anywhere and works in tight spaces and narrow job sites. With true zero tail swing, it lets you complete your jobs with ease while working around walls, buildings or landscaping. Plus, with YANMAR'S unique retractable undercarriage, you can retract or extend when needed to give you additional flexibility.

### QUICK SPECS

Weight	Horsepower	Max Dig Depth
4,023 lbs	14.5 hp	7'7"

### INNOVATIVE FEATURES



#### True Zero Tail Swing

Take on more jobs in tighter spaces. With true zero tail swing technology, no part of the ViO17-1E housing extends beyond the tracks, so you can work efficiently almost anywhere, with less damage to both the machine and the worksite. Plus, you'll enjoy better visibility for increased performance and safety.



#### Unbeatable Track and Undercarriage Flexibility

Tracks hydraulically retract to 37 inches for traveling through narrow passageways, and expand to 50 inches for greater stability while digging. Plus, the folding blade provides even more flexibility.



#### Intuitive Controls

Joystick pilot controls with control pattern change come standard on the ViO17-1E. The easy-to-access valve lets you switch from excavator to backhoe control in just seconds. The wrist control lever and ergonomically designed armrest provide comfortable, easy operation, designed to significantly reduce fatigue on long, tough workdays.



**Specifications**

Model			ViO17-1E	
Operating Weight	Rubber track	lbs (t)	4,023 (1.8)	
Engine	Type	-	Water-cooled 3-cylinder diesel	
	Model	-	YANMAR 3TNV74F-SPBV	
	Output	HP (kW)/rpm	14.5 (10.8) / 2,400	
Performance	Max Digging Force, Bucket / Arm	lbs (kN)	3,474 (15.5) / 1,993 (8.9)	
	Traveling Speed	MPH (km / h)	2.6 / 1.3 (4.2 / 2.1)	
	Swing Speed	RPM	9.5	
	Boom Swing Angle, (L / R)	degrees	42° / 65°	
Ground Contact Pressure (Rubber Track)			PSI (kPa)	4.1 (28.6)
Hydraulic System	Pump Capacity	GPM (L / min)	Double Variable Displacement Pump: 2 x 4.6 (2 x 17.6) Gear Pump: 3.5 (13.2)	
	Main Relief Set Pressure	PSI (MPa)	2,986 (20.6)	
Blade Dimensions	Width x Height	ft-in (mm)	4'2"7/31" x 9" (1,280/950 x 235)	
Fuel tank capacity		Gals (L)	5.3 (20)	

**Standard Equipment**

- Blade
- Boom Swing Function
- Rubber Tracks
- 2-way Pattern Control
- Arm End Auxiliary Valve
- Cylinder Rod Guards (boom, arm, bucket, blade)
- ROPS / FOPS canopy
- Joystick Pilot Controls
- Arm Rests (adjustable)
- High Back Seat
- Seat Belt
- Travel Levers and Pedals
- Traveling Alarm
- Built-in Boom Light
- Variable Track Width
- Operation Manual
- PTO Quick Connect Fittings
- 4-Point Tie Down

Please note that the standard equipment may vary from this list. Consult your YANMAR dealer for confirmation.

**Hydraulic PTO**

Model		ViO17-1E	
Specification	Output	PSI (MPa)	GPM (L / min)
Combined Flow, Double Actions		2,175 (15)	8.5 (32.2)

**Lifting Capacity**

LIFT POINT HEIGHT h:in (mm)	r:REACH in (mm)											
	RATED LIFT CAPACITY OVER END BLADE DOWN				RATED LIFT CAPACITY OVER END BLADE UP				RATED LIFT CAPACITY OVER SIDE BLADE UP			
	MAX	98.5 (2,500)	78.7 (2,000)	59.1 (1,500)	MAX	98.5 (2,500)	78.7 (2,000)	59.1 (1,500)	MAX	98.5 (2,500)	78.7 (2,000)	59.1 (1,500)
78.7 (2,000)	683 (310)	617 (280)			485 (220)	815 (370)			529 (240)	595 (270)		
59.1 (1,500)	705 (320)	694 (315)			418 (190)	694 (315)			473 (215)	694 (315)		
39.4 (1,000)	727 (330)	870 (395)	1,058 (480)		396 (180)	650 (295)	848 (385)		440 (200)	694 (315)	1,047 (475)	
19.7 (500)	760 (345)	1,003 (455)	1,410 (640)		396 (180)	584 (265)	815 (370)		429 (195)	628 (285)	903 (410)	
Ground (0)	793 (360)	1,091 (495)	1,598 (725)	2,171 (985)	396 (180)	562 (255)	793 (360)	1,102 (500)	451 (205)	617 (280)	881 (400)	1,311 (595)
-19.7 (-500)	837 (380)	1,157 (525)	1,543 (700)	2,325 (1055)	429 (195)	573 (260)	749 (340)	1,146 (520)	485 (220)	628 (285)	848 (385)	1,333 (605)
-39.4 (-1,000)	870 (395)	1,025 (465)	1,477 (670)	2,182 (990)	485 (220)	551 (250)	749 (340)	1,157 (525)	551 (250)	617 (280)	826 (375)	1,300 (590)

**Dimensions - ViO17-1E**

- A 7'7" (2,310 mm)
- B 7' 11" (2,410 mm)
- C 3' (930 mm)
- D 12'6" (3,810 mm)
- E 11'5" (3,480 mm)
- F 5' (1,525 mm)
- G 11'3" (3,440 mm)
- H 8'6" (2,590 mm)
- I 5'6" (1,670 mm)
- J 7'7" (2,300 mm)
- K 10" (260 mm)
- L 3'1" (950 mm) / 4'1" (1,280 mm)
- M 10" (250 mm)
- N 7" (175 mm)
- O 5" (125 mm)
- P 2'1" (640 mm)
- Q 1'4" (400 mm)
- R 3" (85 mm)
- S 2'1" (640 mm)

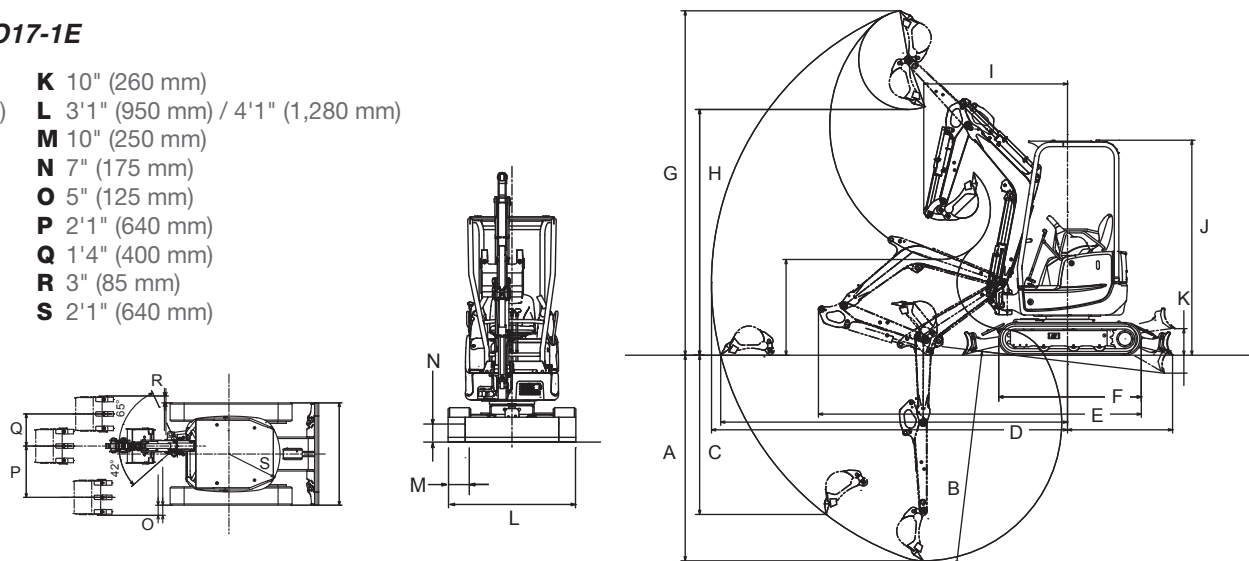

Find more information on the ViO17-1E at [YanmarCE.com](http://YanmarCE.com).