

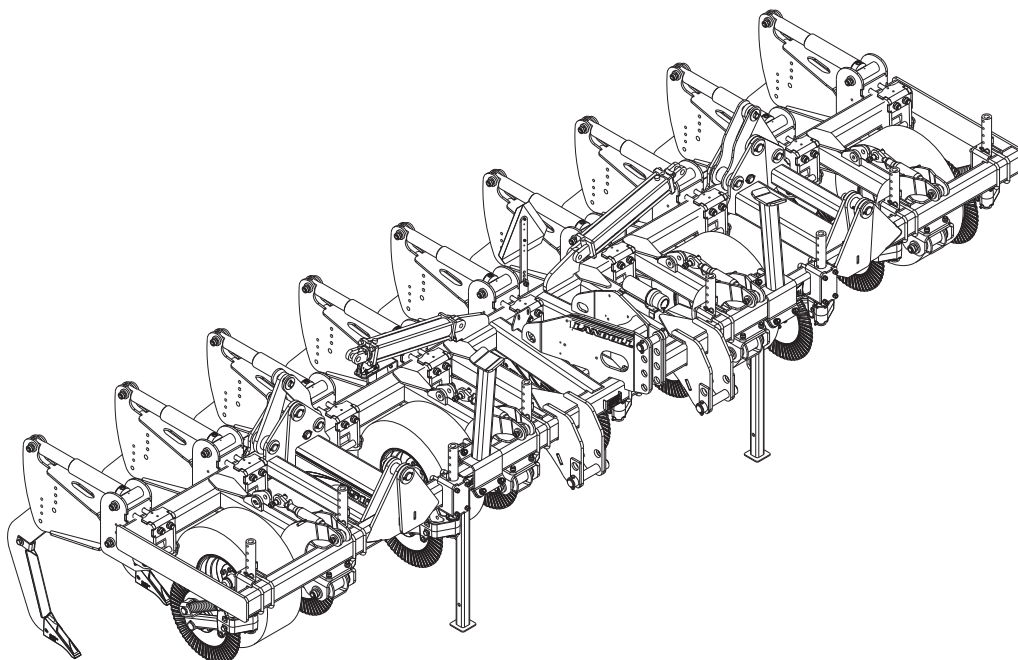

2512 Zone Commander and Caddy

FOR UNITS SHIPPED AFTER DECEMBER 1, 2020
(SN: 25M201237 AND ABOVE)
PREVIOUS UNITS SHOULD REFERENCE F-1040-0320

Operators Manual



LANDOLL COMPANY, LLC

1900 North Street

Marysville, Kansas 66508

(785) 562-5381

800-428-5655 ~ WWW.LANDOLL.COM

Manuals for 2512 Zone Commander

F-1048	2512 Zone Commander Parts Manual
F-1049	2512 Zone Commander Operators Manual
F-1076	Caddy Parts Manual (ONLY)

Table of Contents

1 Introduction and Safety Information

Understanding Safety Statements	1-2
Decal Safety	1-2
Transporting Safety	1-3
Attaching, Detaching, and Storage	1-3
Maintenance Safety	1-3
High Pressure Fluid Safety	1-3
Protective Equipment	1-3
Chemical Safety	1-3
Prepare for Emergencies	1-3
Tire Safety	1-4
Safety Chain	1-4

2 Standard Specifications

Model Specifications	2-1
General Torque Specifications (rev. 4/97)	2-3
Hydraulic Fitting Torque Specifications	2-4
Shank Mounting Dimensions - Rigid	2-5
Shank Mounting Dimensions - Folding	2-10

3 Assembly Instructions

Specific Dangers and Warnings	3-1
Assembly Preparation	3-2
Jackstand Installation	3-2
SMV Bracket Installation	3-2
Shank Assembly	3-3
Coverboard Installation	3-7
Right Hand & Left Hand Coulter Assemblies	3-7
Gauge Wheel	3-7
Electrical Installation	3-11
General Hydraulic Components - Hydraulic Reset Option	3-11
Closer Platform (Option) and Features	3-15

4 Operation and Maintenance

Tractor Preparation	4-2
Zone Commander Operation	4-2
Hydraulic Accumulator Operation	4-2
Attaching to Three-Point Hitch	4-3
Attaching to Caddy	4-3
Hydraulic Fold System	4-5
Field Operation - Three Point Hitch Type	4-6
Wheel Bearing Maintenance	4-6
Coulter Spring Adjustment	4-6
Lubrication	4-6
Storage	4-6

5 Troubleshooting Guide

TABLE OF CONTENTS

Introduction and Safety Information

The Landoll Model 2512 Rigid & Folding Zone Commander are quality products designed to give years of trouble free performance. By following each section of this manual, your system will perform as designed for you and your operation.

- CHAPTER 1** Gives basic instructions on the use of this manual and understanding the safety statements.
- CHAPTER 2** Gives product specifications for the equipment. These specifications supply lengths and measures for your equipment. A Standard Bolt Torque Table is provided to give guidelines for bolt torques to be used when servicing this product.
- CHAPTER 3** Contains assembly instructions for your 2512 Rigid & Folding Zone Commander. When these procedures are correctly followed, your equipment should provide you years of trouble-free operation and service.
- CHAPTER 4** Instructs how to operate your equipment before using it, and describes adjustments needed. Gives practical advice for the care and maintenance of your Landoll equipment. Drawings in this section locate adjustment points on the equipment.

IF YOU HAVE ANY QUESTIONS CONTACT:

LANDOLL COMPANY, LLC
 1900 NORTH STREET
 MARYSVILLE, KANSAS 66508

PHONE # (785) 562-5381 or (800) 428-5655

OR

FAX # (888) 527-3909

- CHAPTER 5** Is a troubleshooting guide to aid in diagnosing and solving problems with the Zone Commander.
- PARTS MANUAL** Is a separate manual showing the various assemblies, subassemblies, and systems. Refer to that manual when ordering Landoll replacement parts. Order parts from your Landoll dealer.
- WARRANTY** The Warranty Registration form is filled out at the time of sale. For questions regarding the product registration, please contact the dealer where the implement was purchased.
NOTE: IMPROPER ASSEMBLY, MODIFICATION, OR MAINTENANCE OF YOUR LANDOLL MACHINE CAN VOID YOUR WARRANTY.
- COMMENTS** Address comments or questions regarding this publication to:

LANDOLL COMPANY, LLC
 1900 NORTH STREET
 MARYSVILLE, KANSAS 66508
ATTENTION: PUBLICATIONS - DEPT. 55

Understanding Safety Statements

You will find various types of safety information on the following pages and on the machine signs (decals) attached to the vehicle. This section explains their meaning.



The Safety Alert Symbol means **ATTENTION! YOUR SAFETY IS INVOLVED!**

NOTE

Means that failure to follow these instructions could cause damage to the equipment or cause it to operate improperly.

NOTICE

Special notice - read and thoroughly understand.



CAUTION

Caution means serious equipment or other property damage can occur if instructions on this label are not properly followed.



WARNING

Warning means serious injury or death can occur if safety measures or instructions on this label are not properly followed.



DANGER

Danger means a life-threatening situation exists. Death can occur if safety measures or instructions on this label are not properly followed.

NOTE

Make sure you read and understand the information contained in this manual and on the machine signs (decals) before you attempt to operate or maintain this vehicle.

The safety statements contained in this manual relate to the operation of the Model 2512 Rigid & Folding Zone Commander.

Decal Safety

1. Examine safety decals and be sure you have the correct safety decals for the implement.
2. Keep these signs clean so they can be observed readily. It is important to keep these decals cleaned more frequently than the implement. Wash with soap and water or a cleaning solution as required.
3. Replace decals that become damaged or lost. Also, be sure that any new implement components installed during repair include decals which are assigned to them by the manufacturer.
4. When applying decals to the implement, be sure to clean the surface to remove any dirt or residue. Where possible, sign placement should protect the sign from abrasion, damage, or obstruction from mud, dirt, oil etc.

**DANGER**

- Do not allow anyone to ride on the tractor or implement. Riders could be struck by foreign objects or thrown from the implement.
- Never allow children to operate equipment.
- Keep bystanders away from implement during operation.

Transporting Safety

IMPORTANT

It is the responsibility of the owner/operator to comply with all state and local laws.

1. When transporting the implement on a road or highway, use adequate warning symbols, reflectors, lights and slow moving vehicle sign as required. Slow moving tractors and towed implements can create a hazard when driven on public roads. They are difficult to see, especially at night.
2. Do not tow an implement that, when fully loaded, weighs more than 1.5 times the weight of the towing vehicle.
3. Carry reflectors or flags to mark the tractor and implement in case of breakdown on the road.
4. Do not transport at speeds over 20 MPH under good conditions. Never travel at a speed which does not allow adequate control of steering and stopping. Reduce speed if towed load is not equipped with brakes.
5. Avoid sudden stops or turns because the weight of the implement may cause the operator to lose control of the tractor. Use a tractor heavier than the implement.
6. Use caution when towing behind articulated steering tractors; fast or sharp turns may cause the implement to shift sideways.
7. Keep clear of overhead power lines and other obstructions when transporting. Know the transport height and width of your implement.

Attaching, Detaching, and Storage

1. Do not stand between the tractor and implement when attaching or detaching implement unless both are not moving.
2. Block implement so it will not roll when unhitched from the tractor.
3. Store in an area where children normally do not play.

Maintenance Safety

1. Understand the procedure before doing the work. Use proper tools and equipment.
2. Make sure all moving parts have stopped.
3. Do not make adjustments or lubricate implement while it is in motion.
4. Block the implement so it will not roll when working on or under it to prevent injury.

High Pressure Fluid Safety

1. Escaping fluid under pressure can be nearly invisible and have enough force to penetrate the skin causing serious injury. Use a piece of cardboard, rather than hands, to search for suspected leaks.
2. Any fluid injected into the skin must be surgically removed within a few hours or gangrene may result.
3. Avoid the hazard by relieving pressure before disconnecting hydraulic lines.

Protective Equipment

1. Wear protective clothing and equipment.
2. Wear clothing and equipment appropriate for the job. Avoid loose fitting clothing.
3. Because prolonged exposure to loud noise can cause hearing impairment or hearing loss, wear suitable hearing protection, such as earmuffs or earplugs.

Chemical Safety

1. Agricultural chemicals can be dangerous. Improper use can seriously injure persons, animals, plants, soil and property.
2. Read chemical manufactures instructions and store or dispose of unused chemicals as specified.
3. Handle chemicals with care and avoid inhaling smoke from any type of chemical fire.
4. Store or dispose of unused chemicals as specified by the chemical manufacturer.

Prepare for Emergencies

1. Keep a First Aid Kit and Fire Extinguisher handy.
2. Keep emergency numbers for doctor, ambulance, hospital and fire department near the phone.

Tire Safety

1. Tire changing can be dangerous and should be performed by trained personnel using correct tools and equipment.
2. When inflating tires, use a clip-on chuck and extension hose long enough to allow you to stand to one side, not in front of or over the tire assembly. Use a safety cage if available.
3. When removing and installing wheels use wheel-handling equipment adequate for the weight involved.

Safety Chain

1. Use a chain with a strength rating equal to or greater than the gross weight of towed machinery, which is 10,100 pounds minimum in accordance with ASAE S338.2 specifications. If two or more implements are pulled in tandem, a larger chain may be required. Chain capacity must be greater than the TOTAL weight of all towed implements.
2. A second chain should be used between each implement.
3. Attach the chain to the tractor drawbar support or specified anchor location. Allow only enough slack in the chain to permit turning. The distance from hitch pin to attachment point or intermediate support point should not exceed 9 inches.
4. Replace the chain if any links or end fittings are broken, stretched or damaged.
5. Do not use a safety chain for towing.

Standard Specifications

Model Specifications

2511N Rigid Zone Commander					
Model	Number of Shanks	Frame Type	Frame Configuration	Transport Width	Estimated Weight
2511N-3-30	3	RIGID	107 (IN) RIGID	110" (9' - 2")	3,357 W/2 GAUGE WHEEL
2511N-4-30	4	RIGID	107 (IN) RIGID	110" (9' - 2")	3,849 W/2 GAUGE WHEEL
2511N-5-30	5	RIGID	107 (IN) RIGID CT, (2) 13 (IN) EXT	140" (11' - 8")	4,725 W/2 GAUGE WHEEL

2512 Rigid and Folding Zone Commander (Caddy Optional)					
Model	Number of Shanks	Frame Type	Frame Configuration	Transport Width	Estimated Weight
2512-4-30	4	RIGID	135 (IN) RIGID	149" (12' - 5")	5,636 W/2 GAUGE WHEEL
2512-5-30	5	RIGID	135 (IN) RIGID	136" (11' - 4")	6,398 W/2 GAUGE WHEEL
2512-6-30	6	RIGID - 1-4-1	135 (IN) RIGID CT, (2) 13 (IN) EXT	161" (13' - 5")	8,209 W/2 GAUGE WHEEL
2512-7-30	7	RIGID - 1-5-1	135 (IN) RIGID CT, (2) 28 (IN) EXT	190" (15' - 10")	9,406 W/2 GAUGE WHEEL
2512-8-30	8	RIGID - 2-4-2	135 (IN) RIGID CT, (2) 44 (IN) WING	223" (18' - 6")	10,473 W/2 GAUGE WHEEL
2512F-7-30	7	FOLDING - 1-5-1	150 (IN) RIGID CT, (2) 24 (IN) WING	167" (13' - 11")	10,422 W/2 GAUGE WHEEL
2512F-8-30	8	FOLDING - 1-6-1	180 (IN) RIGID CT, (2) 24 (IN) WING	197" (16' - 5")	11,559 W/2 GAUGE WHEEL
2512F-9-30	9	FOLDING - 2-5-2	150 (IN) RIGID CT, (2) 52 (IN) WING	167" (13' - 11")	12,721 W/2 GAUGE WHEEL ON WINGS

2512 Folding Zone Commander (Caddy ONLY)					
Model	Number of Shanks	Shank Spacing	Shank Extensions	Transport Width	Estimated Weight
2512F-10-30	10	FOLDING - 2-6-2	180 (IN) CENTER CT, (2) 52 (IN) WING	197" (16' - 5")	13,872 W/2 GAUGE WHEEL ON WINGS
2512F-11-30	11	FOLDING - 2-7-2	210 (IN) CENTER CT, (2) 52 (IN) WING	227" (18' - 11")	14,924 W/2 GAUGE WHEEL ON WINGS
2512F-12-30	12	FOLDING - 3-6-3	150 (IN) CENTER CT, (2) 82 (IN) WING	197" (16' - 5")	16,045 W/2 GAUGE WHEEL ON WINGS
2512F-13-30	13	FOLDING - 3-7-3	210 (IN) CENTER CT, (2) 82 (IN) WING	227" (18' - 11")	17,097 W/2 GAUGE WHEEL ON WINGS
2512F-14-30	14	FOLDING - 3-8-3	240 (IN) CENTER CT, (2) 82 (IN) WING	257" (21' - 5")	18,430 W/2 GAUGE WHEEL ON WINGS
2512F-15-30	15	FOLDING - 4-7-4	210 (IN) CENTER CT, (2) 112 (IN) WING	227" (18' - 11")	19,299 W/2 GAUGE WHEEL ON WINGS
2512F-16-30	16	FOLDING - 4-8-4	240 (IN) CENTER CT, (2) 112 (IN) WING	257" (21' - 5")	20,731 W/2 GAUGE WHEEL ON WINGS

TABLE OF CONTENTS

STANDARD SPECIFICATIONS

Tire Inflation			
Model	Tire Size	Ply/Load Rating	Inflation Pressure (Psi) (Max.)
Caddy STD	IF 320/70R15	144	70 psi
Caddy HD	VF 385/65R22.5	163	70 psi
Gauge Wheels	IF280/70R15	134	64 psi
Gauge Wheels	20.5 X 8.0 X 10	D	70 psi

Recommended Torque Specification For Lug Bolts and Nuts	
Bolt Size	Torque (FT. LBS.)
9/16-18 (Heavy Duty Disc)	80 - 90 FT. LBS.

General Torque Specifications (rev. 4/97)

TORQUE SPECIFIED IN FOOT POUNDS - This chart provides tightening torques for general purpose applications when special torques are not specified on process or drawing. Assembly torques apply to plated nuts and capscrews assembled without supplemental lubrication (as received condition). They do not apply if special graphite moly-disulfide or other extreme pressure lubricants are used. When fasteners are dry (solvent cleaned) add 33% to as received condition torque. Bolt head identification marks indicate grade and may vary from manufacturer to manufacturer. Thick nuts must be used on grade 8 capscrews. Use value in [] if using prevailing torque nuts.

UNC SIZE	SAE Grade 2	SAE Grade 5	SAE Grade 8	UNF SIZE	SAE Grade 2	SAE Grade 5	SAE Grade 8
1/4-20	4 [5]	6 [7]	9 [11]	1/4-28	5 [6]	7 [9]	10 [12]
5/16-18	8 [10]	13 [13]	18 [22]	5/16-24	9 [11]	14 [17]	20 [25]
3/8-16	15 [19]	23 [29]	35 [42]	3/8-24	17 [21]	25 [31]	35 [44]
7/16-14	24 [30]	35 [43]	55 [62]	7/16-20	27 [34]	40 [50]	60 [75]
1/2-13	35 [43]	55 [62]	80 [100]	1/2-20	40 [50]	65 [81]	90 [112]
9/16-12	55 [62]	80 [100]	110 [137]	9/16-18	60 [75]	90 [112]	130 [162]
5/8-11	75 [94]	110 [137]	170 [212]	5/8-18	85 [106]	130 [162]	180 [225]
3/4-10	130 [162]	200 [250]	280 [350]	3/4-16	150 [188]	220 [275]	320 [400]
7/8-9	125 [156]	320 [400]	460 [575]	7/8-14	140 [175]	360 [450]	500 [625]
1-8	190 [237]	408 [506]	680 [850]	1-14	210 [263]	540 [675]	760 [950]
1-1/8-7	270 [337]	600 [750]	960 [1200]	1-1/8-12	300 [375]	660 [825]	1080 [1350]
1-1/4-7	380 [475]	840 [1050]	1426 [1782]	1-1/4-12	420 [525]	920 [1150]	1500 [1875]
1-3/8-6	490 [612]	1010 [1375]	1780 [2225]	1-3/8-12	560 [700]	1260 [1575]	2010 [2512]
1-1/2-6	650 [812]	1460 [1825]	2360 [2950]	1-1/2-12	730 [912]	1640 [2050]	2660 [3325]
1-3/4-5	736 [920]	1651 [2063]	2678 [3347]	1-3/4-12	920 [1150]	2063 [2579]	3347 [4183]

METRIC:

Coarse thread metric class 10.9 fasteners and class 10.0 nuts and through hardened flat washers, phosphate coated, Rockwell "C" 38-45. Use value in [] if using prevailing torque nuts.

Nominal thread diameter (mm)	Newton Meters (Standard Torque)	Foot Pounds (Standard Torque)	Nominal Thread Diameter (mm)	Newton Meters (Standard Torque)	Foot Pounds (Standard Torque)
6	10 [14]	7 [10]	20	385 [450]	290 [335]
7	16 [22]	12 [16]	24	670 [775]	500 [625]
8	23 [32]	17 [24]	27	980 [1105]	730 [825]
10	46 [60]	34 [47]	30	1330 [1470]	990 [1090]
12	80 [125]	60 [75]	33	1790 [1950]	1340 [1450]
14	125 [155]	90 [115]	36	2325 [2515]	1730 [1870]
16	200 [240]	150 [180]	39	3010 [3210]	2240 [2380]
18	275 [330]	205 [245]			

Figure 2-1: General Torque Specifications

Hydraulic Fitting Torque Specifications

TORQUE IS SPECIFIED IN FOOT POUNDS- 37° JIC, ORS, & ORB (REV. 10/97)			
This chart provides tightening torques for general purpose applications when special torques are not specified on process or drawing. Assembly torques apply to plated nuts and capscrews assembled without supplemental lubrication (as received condition). They do not apply if special graphite moly-disulfide or other extreme pressure lubricants are used. When fasteners are dry (solvent cleaned) add 33% to as received condition torque. Bolt head identification marks indicate grade and may vary from manufacturer to manufacturer. Thick nuts must be used on grade 8 capscrews. Use value in [] if using prevailing torque nuts.			
Parker Brand Fittings			
Dash Size	37 Degree JIC	O-Ring (ORS)	O-Ring Boss (ORB)
-4	11-13	15-17	13-15
-5	14-16	-----	21-23
-6	20-22	34-36	25-29
-8	43-47	58-62	40-44
-10	55-65	100-110	58-62
-12	80-90	134-146	75-85
-16	115-125	202-218	109-121
-20	160-180	248-272	213-237
-24	185-215	303-327	238-262
-32	250-290	-----	310-340
Gates Brand Fittings			
Dash Size	37 Degree JIC	O-Ring (ORS)	O-Ring Boss (ORB)
-4	10-11	10-12	14-16
-5	13-15	-----	-----
-6	17-19	18-20	24-26
-8	34-38	32-40	37-44
-10	50-56	46-56	50-60
-12	70-78	65-80	75-83
-14	-----	65-80	-----
-16	94-104	92-105	111-125
-20	124-138	125-140	133-152
-24	156-173	150-180	156-184
-32	219-243	-----	-----
Aeroquip Brand Fittings			
Dash Size	37 Degree JIC	O-Ring (ORS)	O-Ring Boss (ORB)
-4	11-12	10-12	14-16
-5	15-16	-----	16-20
-6	18-20	18-20	24-26
-8	38-42	32-35	50-60
-10	57-62	46-50	75-80
-12	79-87	65-70	125-135
-14	-----	-----	160-180
-16	108-113	92-100	200-220
-20	127-133	125-140	210-280
-24	158-167	150-165	270-360
-32	245-258	-----	-----

Figure 2-2: Hydraulic Fitting Torque Specifications

Shank Mounting Dimensions - Rigid

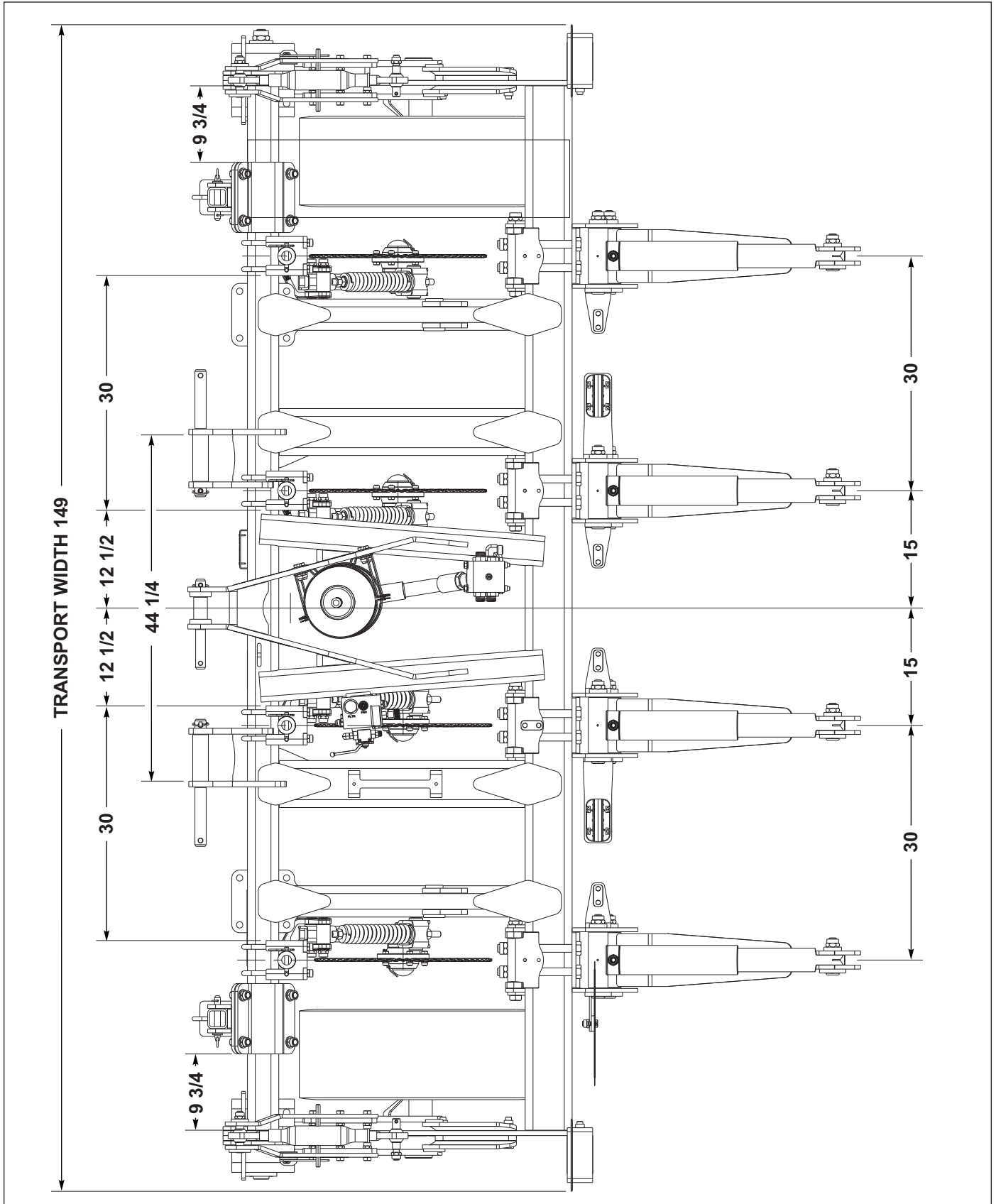

Figure 2-3: 4-Shank Spacing

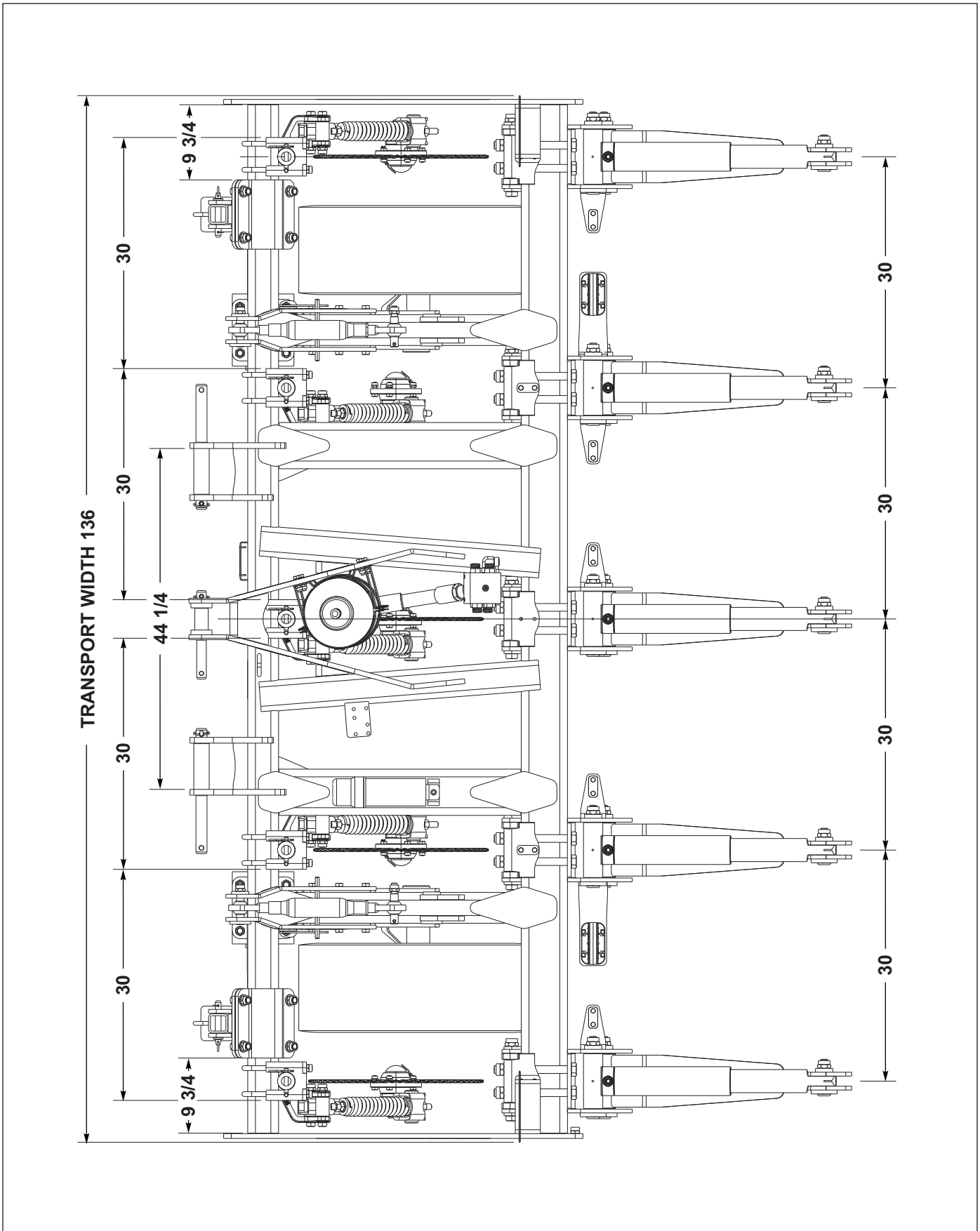

Figure 2-4: 5-Shank Spacing

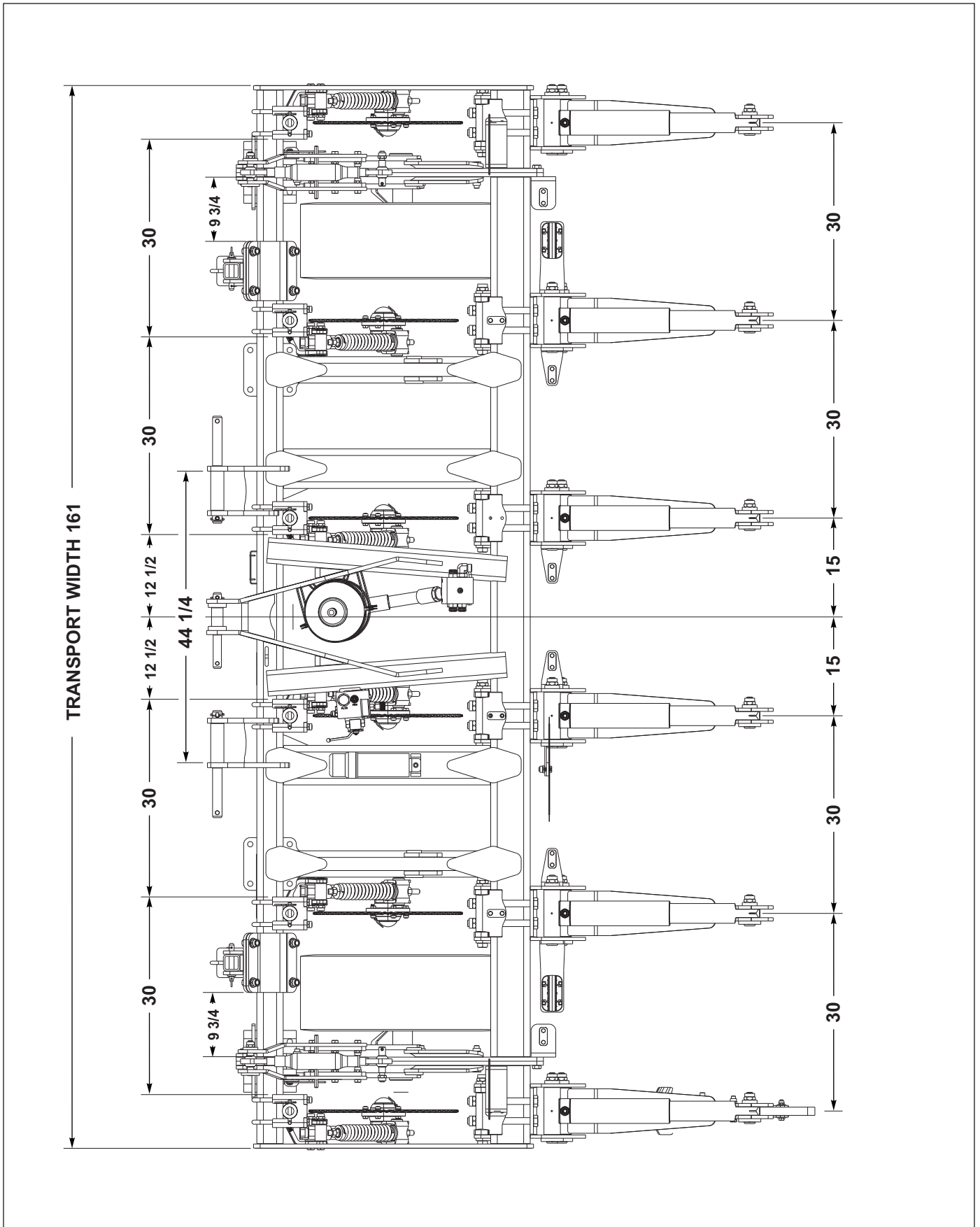

Figure 2-5: 6-Shank Spacing

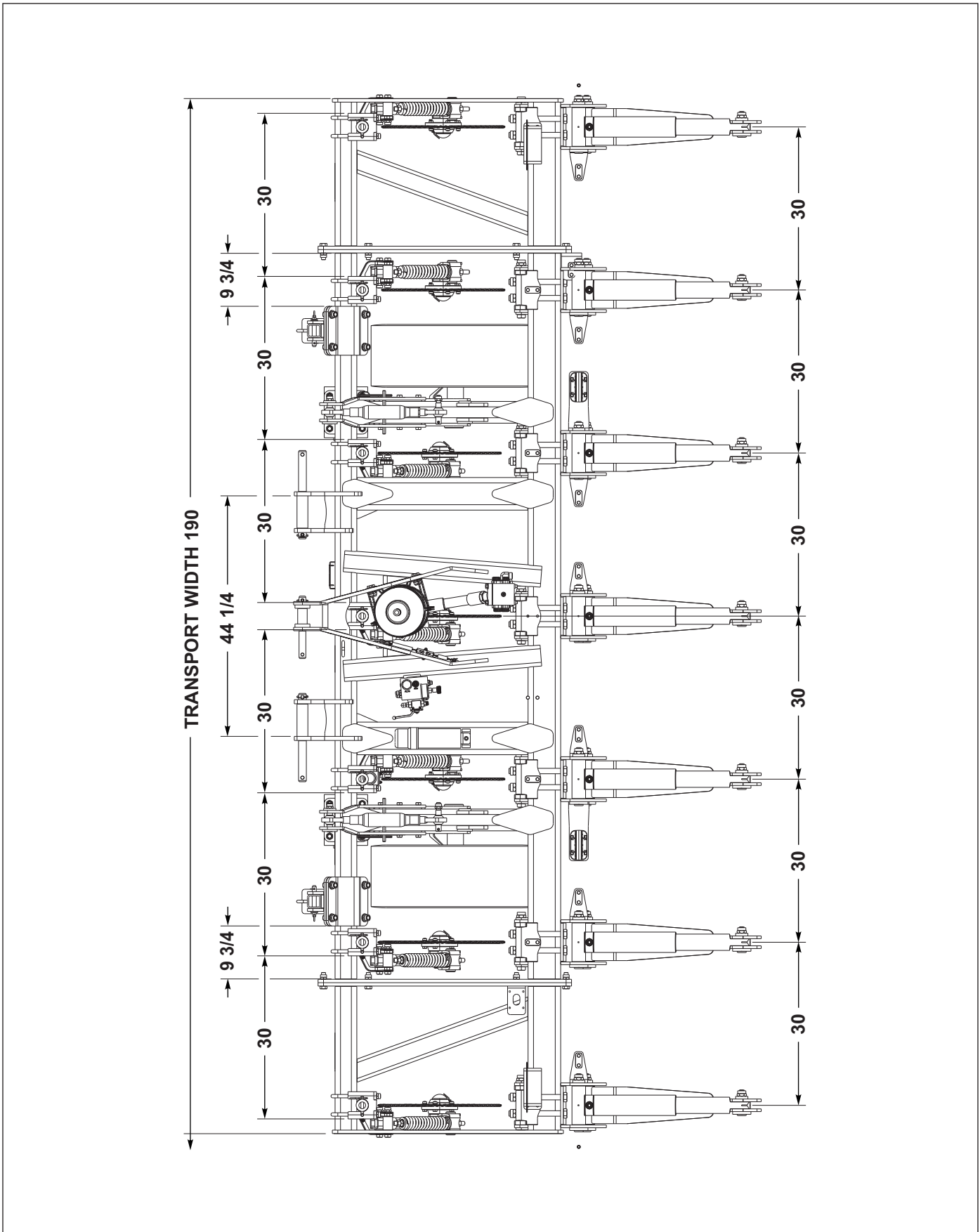

Figure 2-6: 7-Shank Spacing

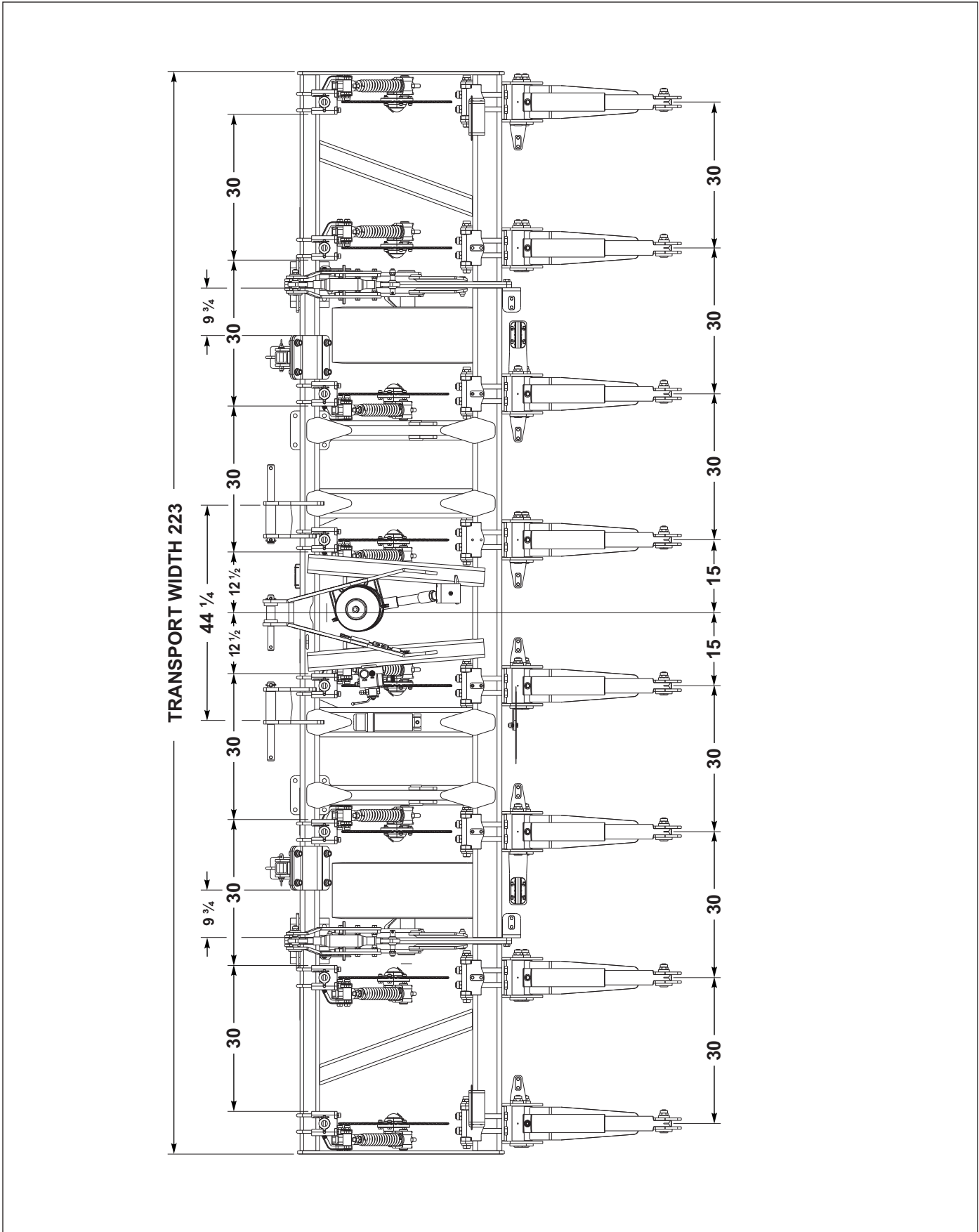

Figure 2-7: 8-Shank Spacing

Shank Mounting Dimensions - Folding

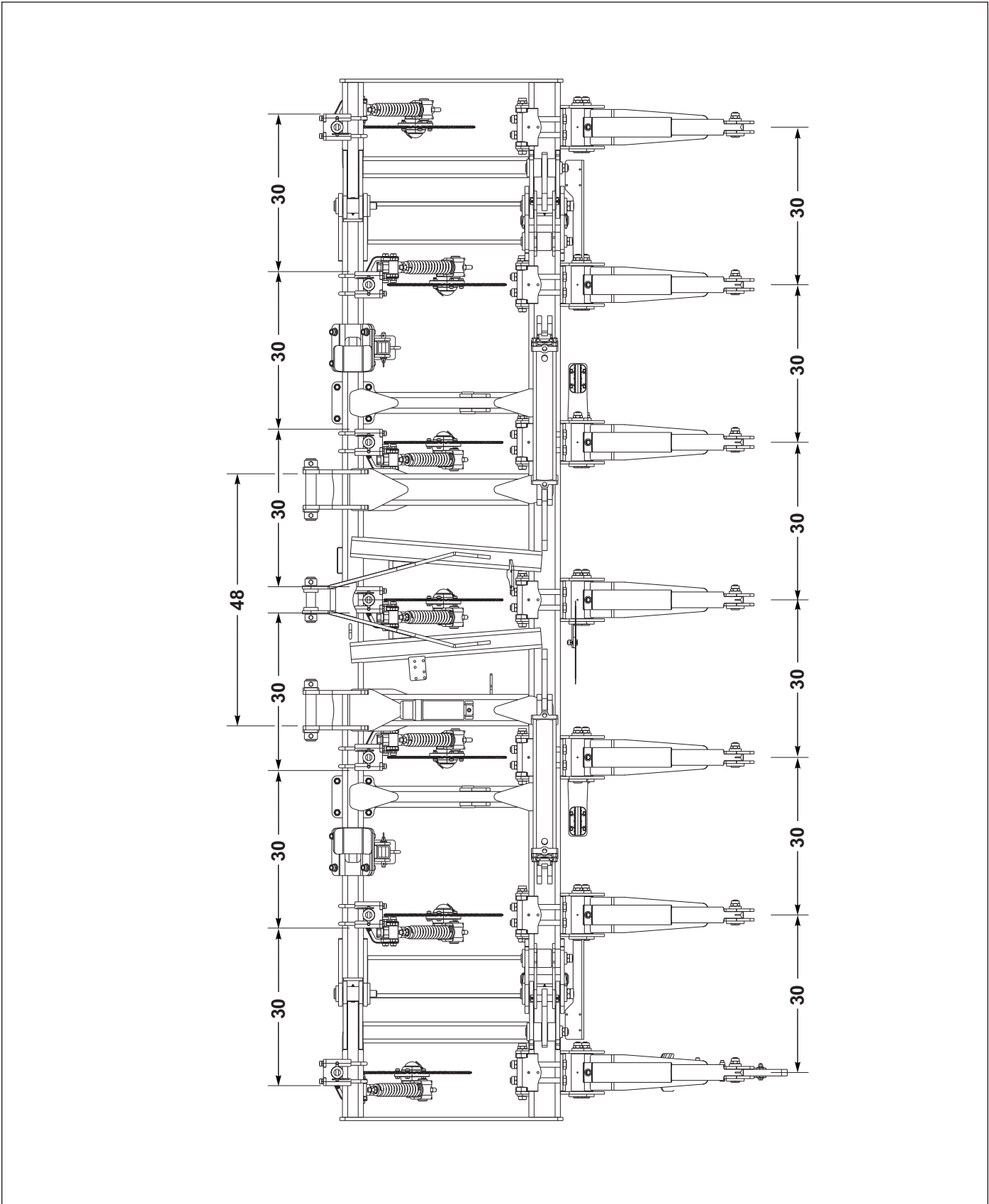

Figure 2-8: Folding - 7 Shank Spacing

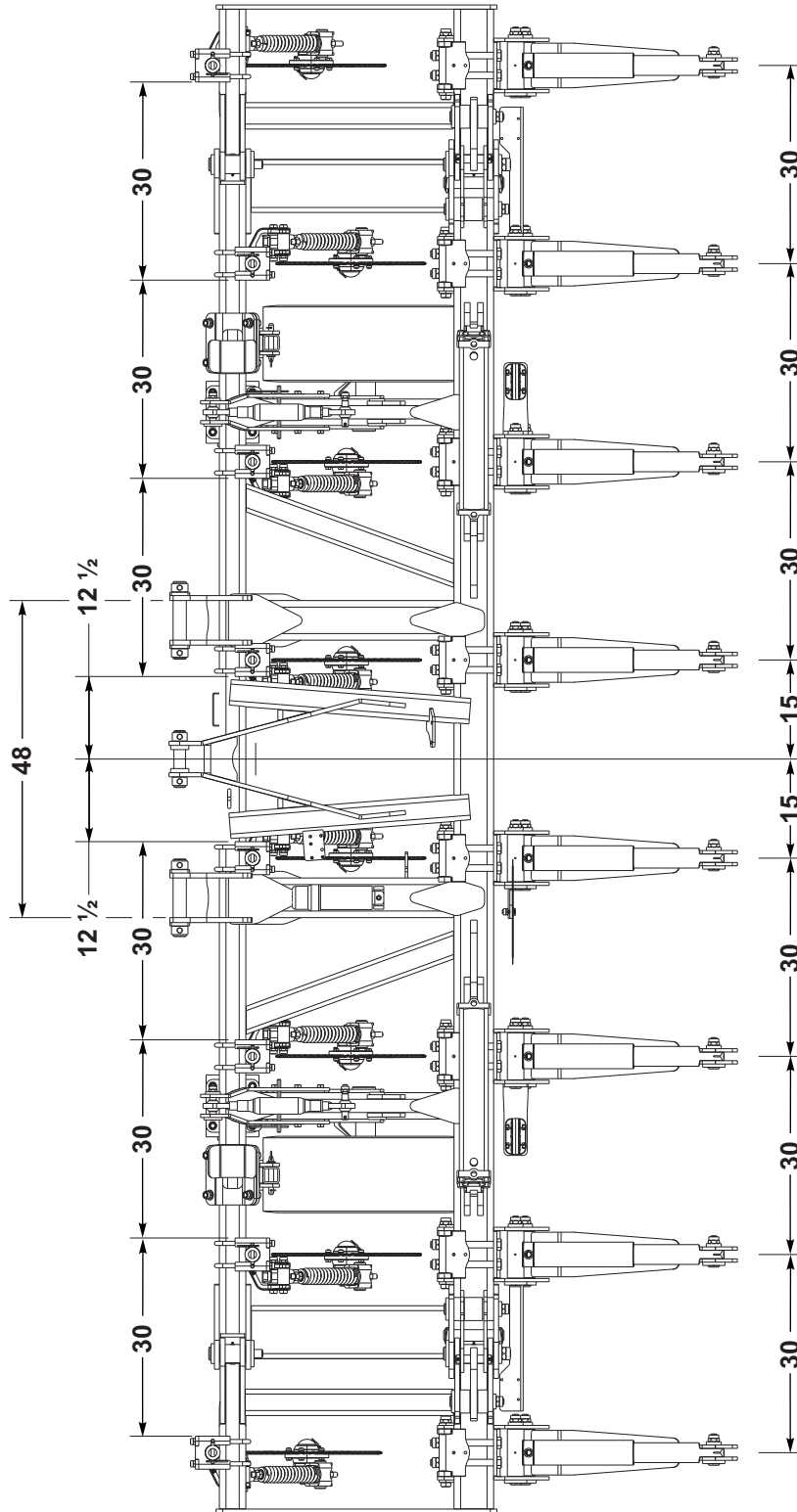

Figure 2-9: Folding - 8 Shank Spacing

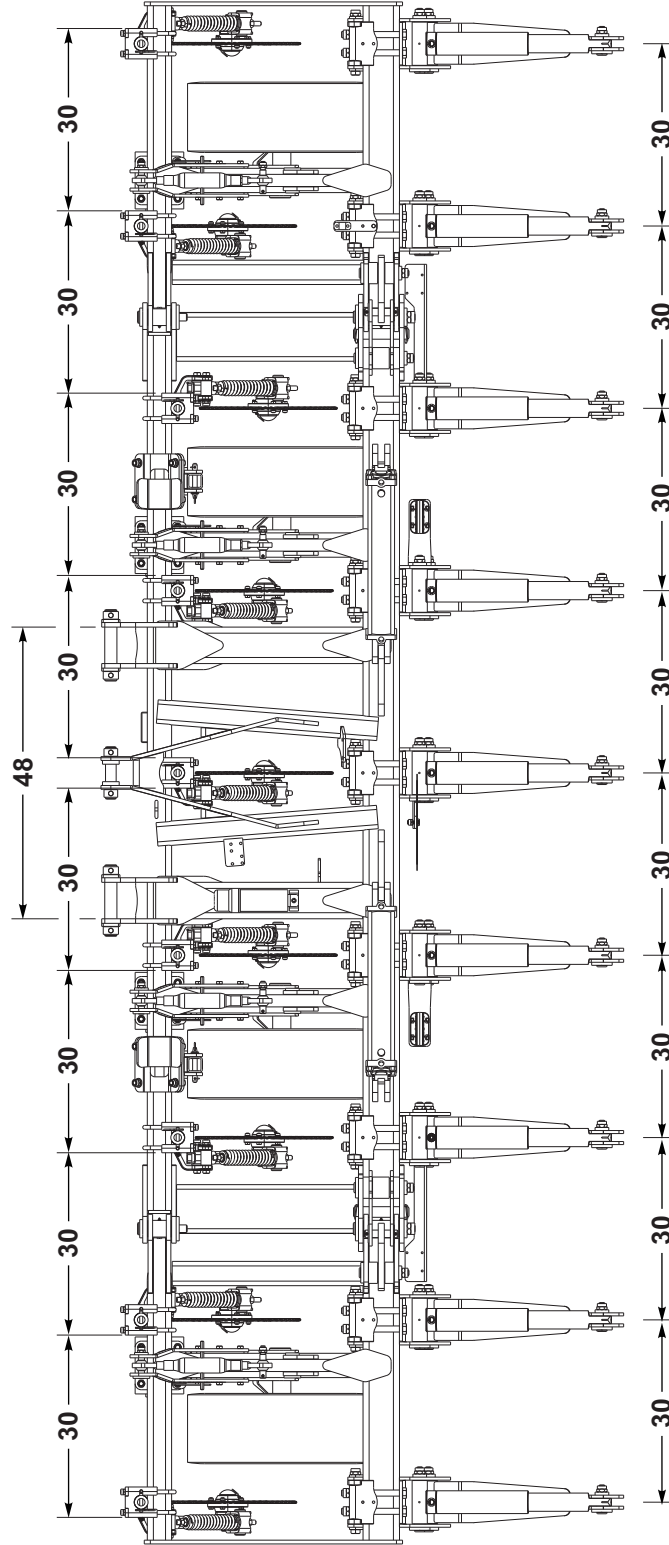

Figure 2-10: Folding - 9 Shank Spacing

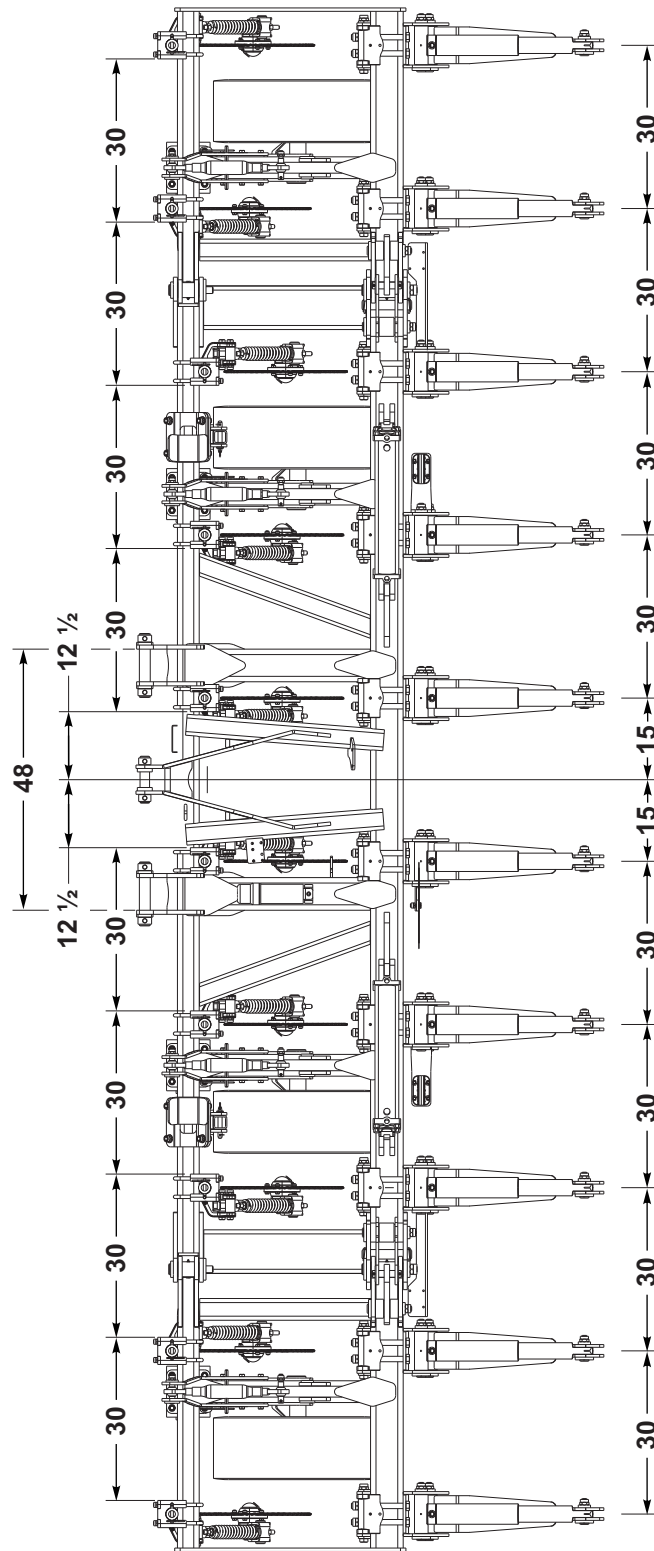

Figure 2-11: Folding - 10 Shank Spacing

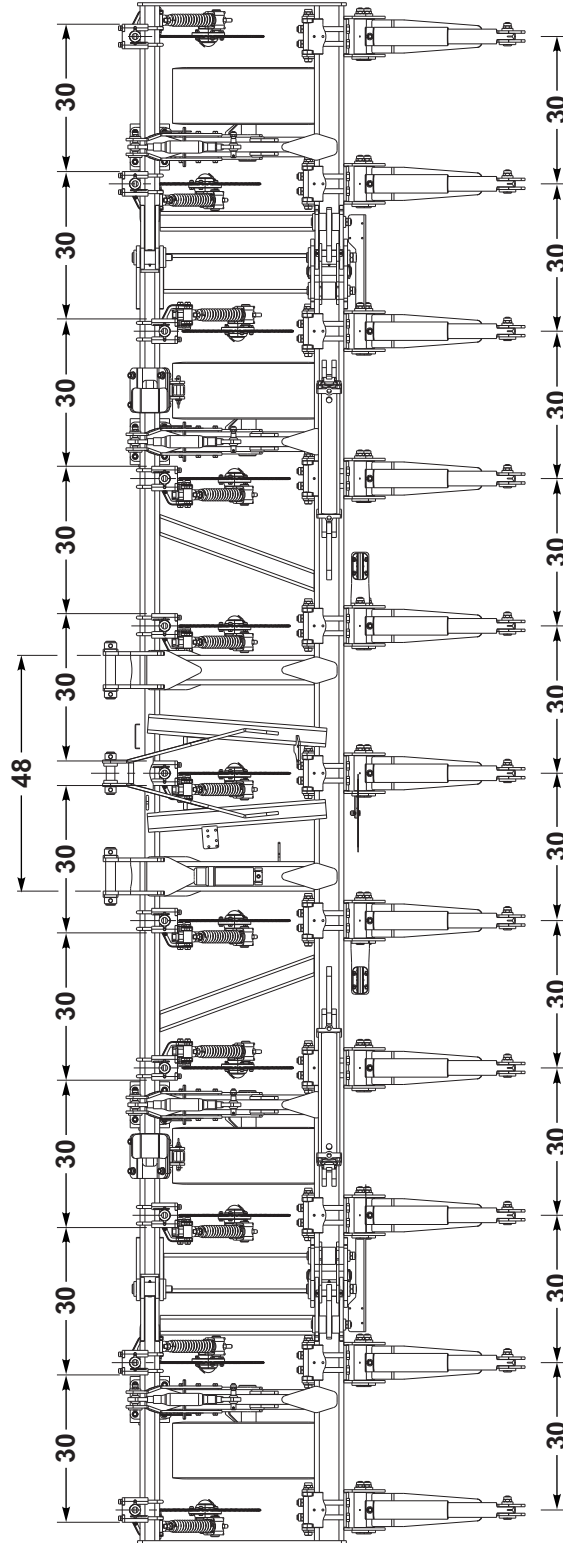

Figure 2-12: Folding - 11 Shank Spacing

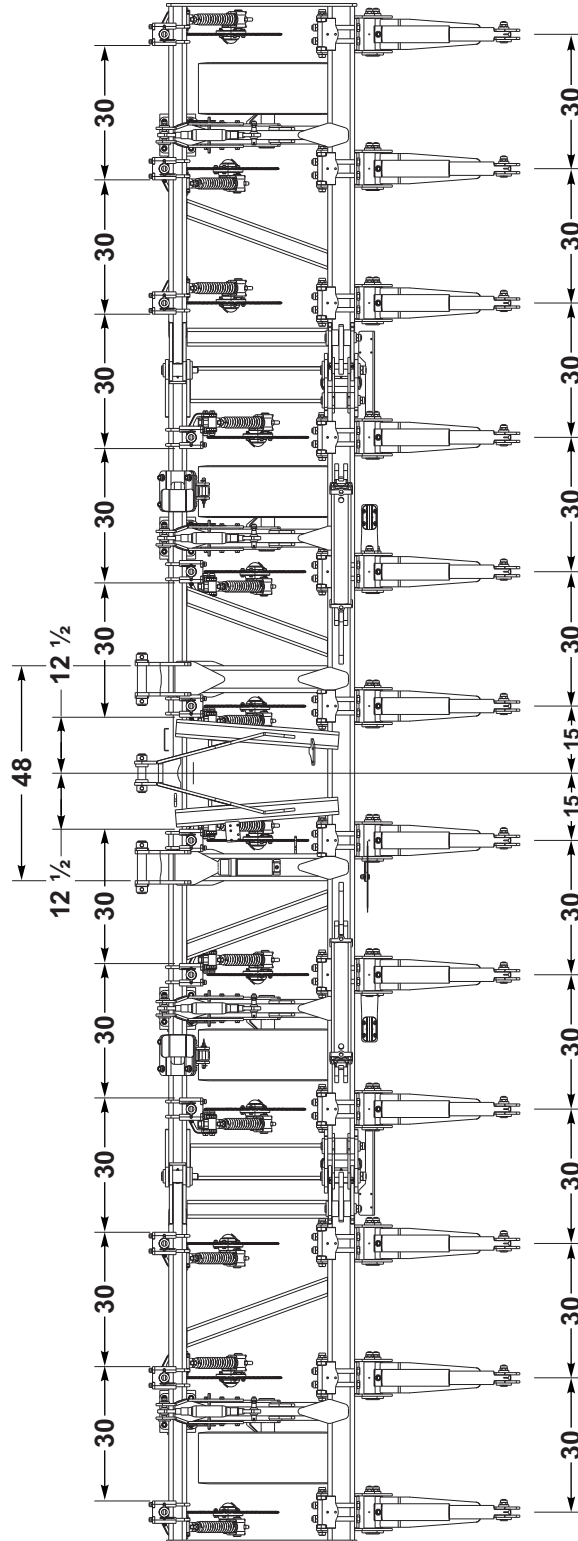

Figure 2-13: Folding - 12 Shank Spacing

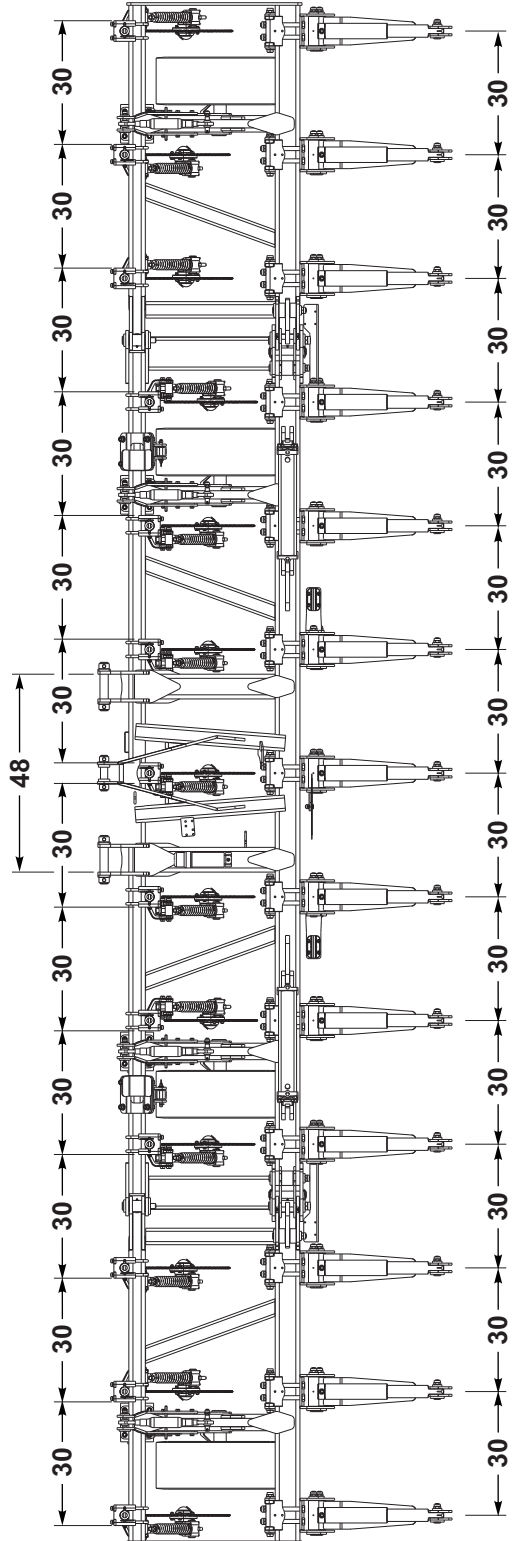

Figure 2-14: Folding - 13 Shank Spacing

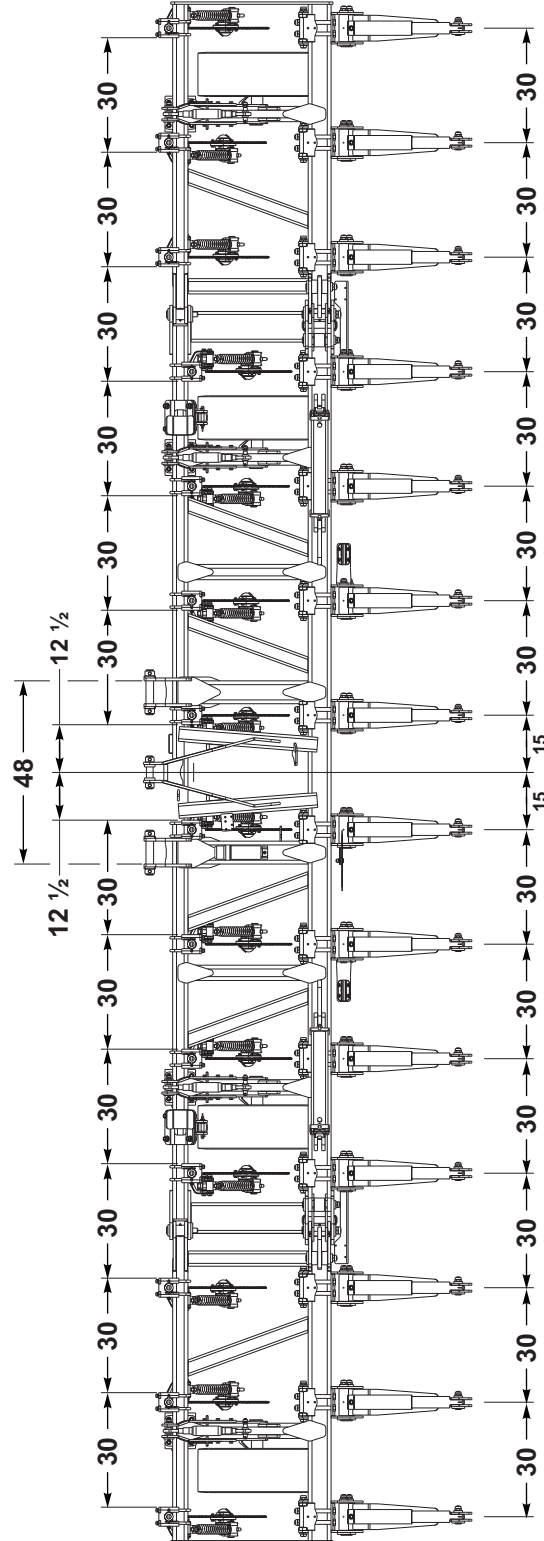

Figure 2-15: Folding - 14 Shank Spacing

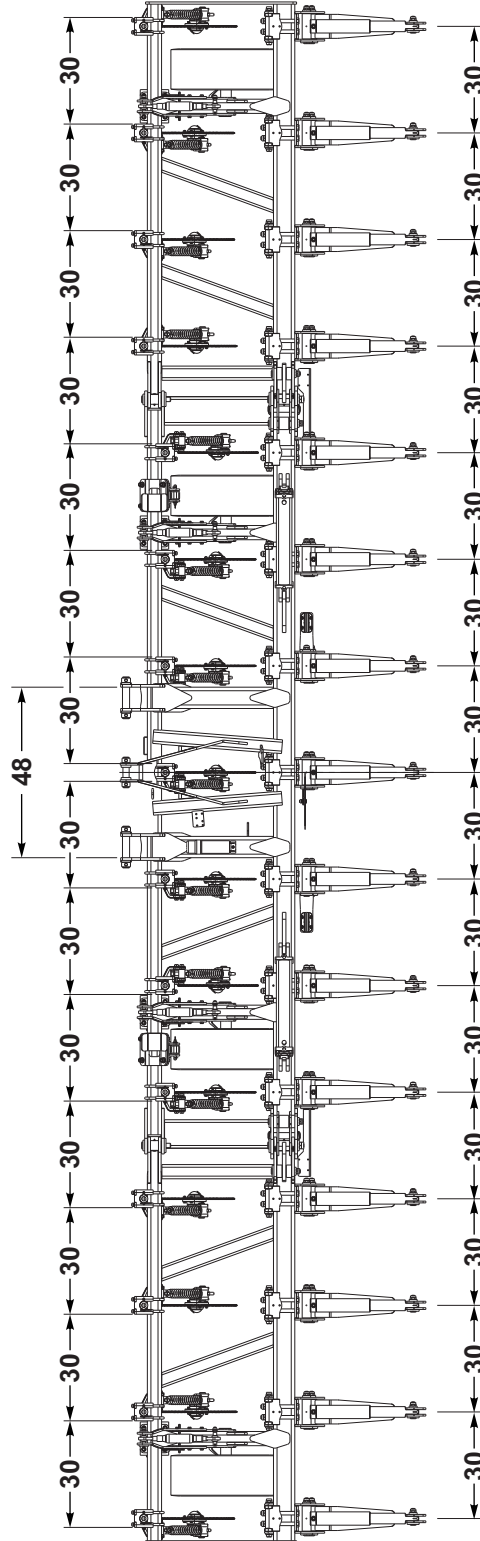

Figure 2-16: Folding - 15 Shank Spacing

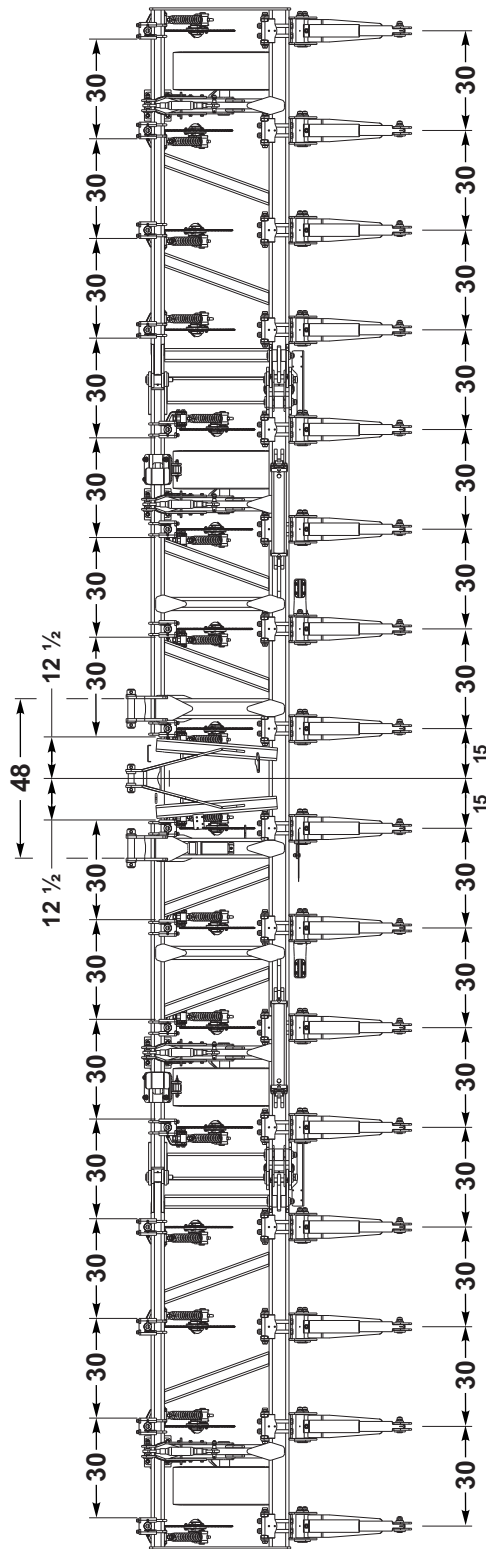

Figure 2-17: Folding - 16 Shank Spacing

Assembly Instructions

It is very important that your new 2512 Series Rigid or Folding Zone Commander be properly assembled, adjusted, and lubricated before use. Illustrations are provided in this section to show proper assembly procedures. Remove paint from grease fittings and replace any that are damaged or missing. Be sure to return bolts, clips, etc. to their original locations.

To ensure assemblies are aligned, **insert all bolts and leave the nuts loose until completion of final assembly.** Use lock washers or flat washers where called for. Spread all cotter pins.

After completion of final assembly, tighten all nuts **evenly** to prevent misalignment, distortion, or binding. Tighten all bolts and nuts to the recommended torques shown on [Page 2-3](#) and [Page 2-4](#). Tighten all u-bolt legs evenly.

IMPORTANT

Check all bolt lengths, nut sizes, etc., from the parts book before assembly. Different models of the 2512 Series Rigid & Folding Zone Commander use different size bolts.

Specific Dangers and Warnings



DANGER

In the event a shank trips and does not release, do not attempt to release the shank. Contact your Landoll dealer for further instructions. A tripped shank can release suddenly and cause serious injury or death.



DANGER

Coulter blades are extremely sharp. use extreme care when working on or near coulter blades. Do not allow coulters to roll over or fall on any part of body. Do not allow wrenches to slip when working near coulter blades. Never push wrenches towards coulter blades. Do not climb over machine above coulter blades. Failure to stay clear of coulter blade edges may result in serious personal injury or death.



DANGER

To prevent accidental lowering:

1. All hydraulically elevated equipment must be locked out using the cylinder lockouts.
2. Lower equipment to the ground while servicing or when it is idle.

Failure to take measures to prevent accidental lowering may result in serious personal injury or death.



WARNING

Be sure to bleed the hydraulic system of all air in lines after installation. Failure to bleed the system of all air may cause the machine to operate improperly.

ASSEMBLY INSTRUCTIONS

Assembly Preparation

1. Hook up the Zone Commander to a tractor using the three-point hitch.
2. Raise the unit about 36" and place stands under the main frame to prevent accidental lowering.

WARNING

Do not attempt to lift heavy parts (such as the frame), manually. Use a hoist or a forklift to move these parts into position.

Jack Stand Installation

NOTE

The implement jack stands must be stored "off the machine" for all **folding machines** during transport and field operation. This is true for both front and rear jack stands.

Front Jack Stands - W/ Mount Bracket

1. With the Jack Stand Weldment Bracket positioned on the bottom side of the front Frame, (clamp facing out), attach the Jack Mount Bracket to the top using 3/4-10 x 2-1/4 Bolts, 3/4 Flat Washer and 3/4-10 Locknut.
2. Insert the Jack Stand Weldment through the bottom of the Jack Stand Weldment Bracket with the handle facing out and pin at desired level (top five holes), with 3/4 x 4 Hitch Pin and hair pin. (See Figure 3-1.)
3. For transport, remove the jack stand Hitch Pin, and raise the Jack Stand Weldment up and re-pin through bottom hole.

Front Jack Stands - W/ Wing-Rest Weldment

4. With the Jack Stand Weldment Bracket positioned on the bottom side of the front Frame, (clamp facing out), attach the appropriate Wing-Rest Weldment using 3/4-10 x 2-1/4 Bolts, 3/4 Flat Washer and 3/4-10 Locknut. (The Wing-Rest Weldments have right hand and left hand designations. The left hand Wing-Rest Plate Stops slope down toward the left and the right hand Wing-Rest Plate Stops slope down toward the right. See Parts Manual for Wing-Rest Weldments according to model number.) (See Figure 3-1.)
5. Insert the Jack Stand Weldment through the bottom of the Jack Stand Weldment Bracket with the handle facing out and pin at desired level (top five holes), with 3/4 x 4 Hitch Pin and hair pin.
6. For transport, remove the jack stand Hitch Pin, and store the Jack Stand Weldment "off the machine."

Rear Jack Stands (Rigid and Folding)

1. With the Jack Stand Mount Bracket positioned on the bottom side of the rear Frame, attach the Jack Stand Weldment Bracket (with the clamp facing out), using 1-8 x 3 Bolts, 1" Flat Washers and 1-8 Locknuts. (See Figure 3-2.)
2. Insert the Jack Stand Weldment through the bottom of the Jack Stand Weldment Bracket and secure with the 1 x 6 Pin and 1/4 x 1-1/4 Lynch Pin.

For transport, remove the jack stand Lynch Pin and store the Jack Stand Weldment "off the machine."

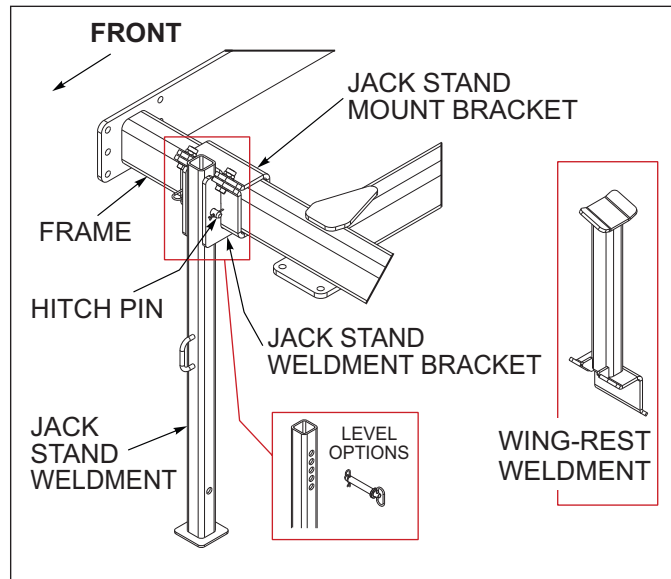

Figure 3-1: Front Jack Stand

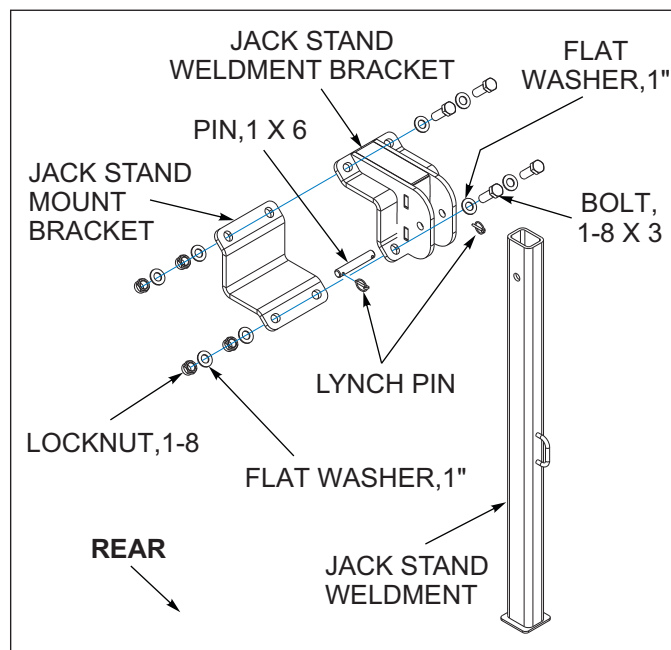

Figure 3-2: Rear Jack Stand

SMV Bracket Installation

1. Attach the SMV mounting bracket at a point where emblem is visible from rear of machine, using U-Bolt and 5/8-11 flange head serrated nuts ([See Figure 3-3.](#))
2. Attach SMV emblem to top of SMV mounting bracket using 1/4-20 x 1 hex head cap screws, Flat Washers, and Hex Locknuts ([See Figure 3-11.](#))

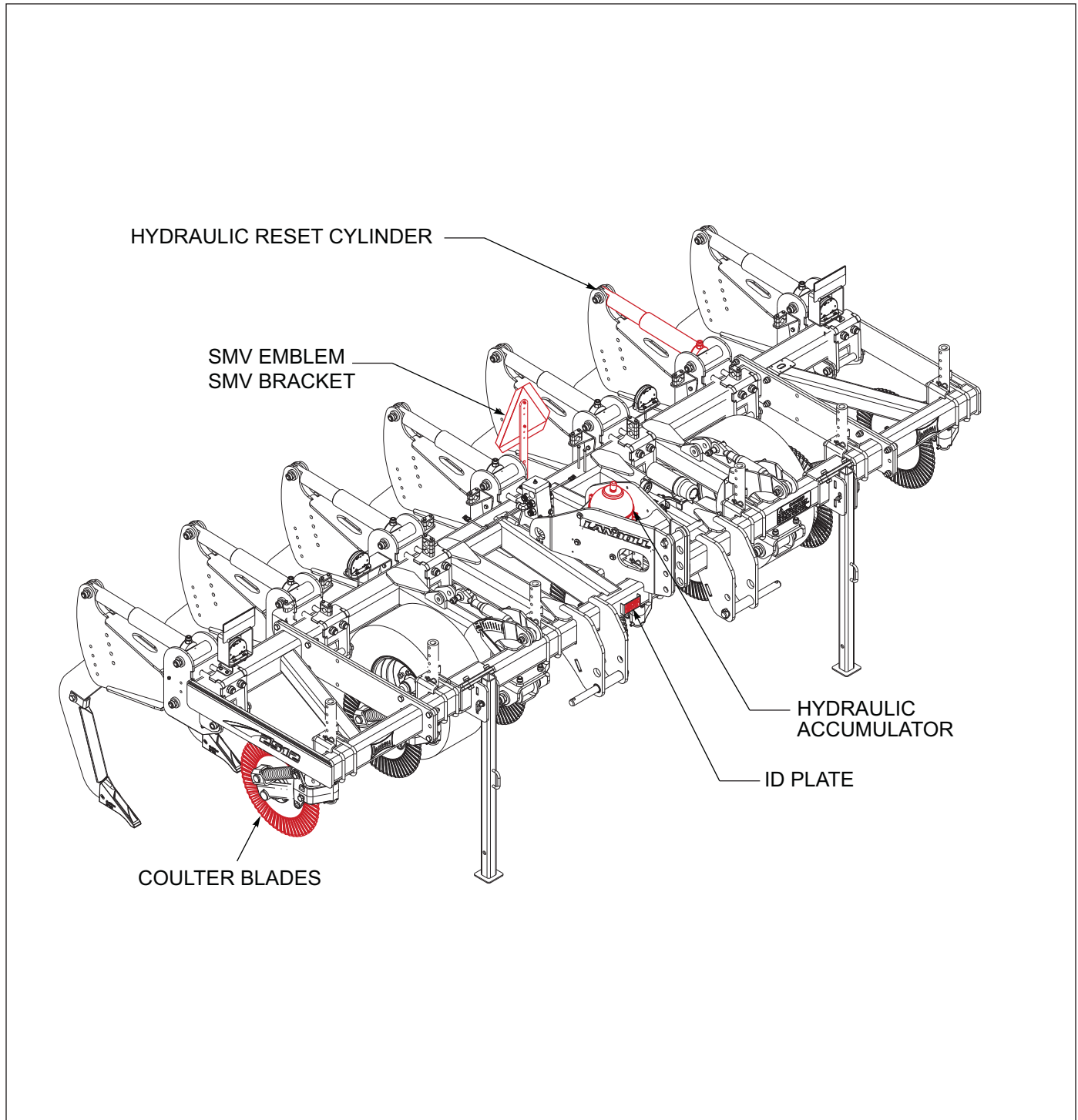

Figure 3-3: 2512 Series Parts Identification

Shank Assembly

The following instructions are for attaching the shanks to the Auto-Reset Shank Clamp (Spring) and the Auto-Reset Shank Clamp (Hydraulic), or the RSB Shank Clamp. (See Figures 3-4 through 3-6.)

There are three shank options to choose from: Parabolic Shank 1-1/4, Straight Leg Shank 1-1/4, and Straight Leg Shank 3/4 (also known as "Low Disturbance Shank").

1. The Clamp weldments are already located on the frame at the proper spacing.
2. Insert a Connex Bushing (P/N 150244) into the second hole from the upper end of the shank. Attach the shank to the front set of mounting holes in the clamp assembly using a 3/4-10 x 4 Bolt and 3/4-10 Locknut. **(A)**. Attach lower hole of shank to rear set of mounting holes in the clamp assembly using 5/8-11 x 3-3/4 Bolt, and 5/8-11 Locknut. **(B)**.

Adjustment holes are provided in the clamp weldment to compensate for varying ground conditions and depths of operation.

NOTE

Select the relative depth the shank will operate at. The Auto-Reset Shank Clamps have four shank mounting holes. There is approximately a 2" differential between holes. The two lower holes will allow for deeper working depths (16" to 20"). The upper two holes will allow for higher shank point loads. That is to say the upper holes are conducive to keeping the shanks properly engaged in the ground.

The RSB Clamp has three holes: the top hole has a maximum operating depth up to 14", the lower two holes have operating depths ranging from 16" to 20".

Landoll recommends using the top upper holes for optimal machine efficiency.

3. Attach shank point to each shank using 1/2 x 2 and 5/16 x 2 Spring Slotted Pins. Place pins with open ends oriented opposite of each other.
For Parabolic Shank 1-1/4, manufactured before 08/30/2020 use 3/8 x 2 Slotted Roll Pin.
4. Place Wearstrip on shank leg with the lower Wearstrip tab in the pocket the shank point provides.

NOTE

Assembling the shank point first will provide a provision for securing the lower tab of the wearstrip when it is assembled.

5. Secure Wearstrip to shank leg using Wearstrip Bracket, with appropriate 1/2-13 x 2-3/4 Bolts, 1/2 Flat Washers and 1/2-13 Locknuts. **(C)**.

 WARNING
Shank Clamp Mounting Bolts <u>MUST BE TIGHTENED</u> to 200FT LB (3/4-10 X 4), and 170 FT LB (5/8-11 X 3-3/4) respectively. Failure to do so may cause Shank Clamp damage. (SEE STEP 2, (A) AND (B).

 DANGER
Auto-Reset Spring Clamp is NOT to be operated at depths greater than 14".

⚠ DANGER
 OPERATING AT A DEPTH THAT EXCEEDS THE MAXIMUM SHANK TRIP HEIGHT EXPOSES THIS MACHINE TO DAMAGE THAT MAY LEAD TO PERSONAL INJURY OR DEATH.

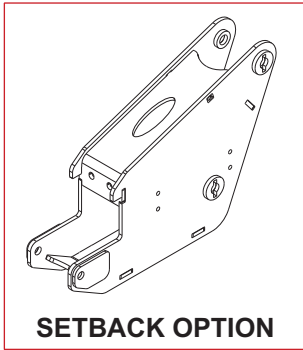

SETBACK OPTION

TORQUE THE GATE CLAMP BOLTS TO 300-400 FT/LBS

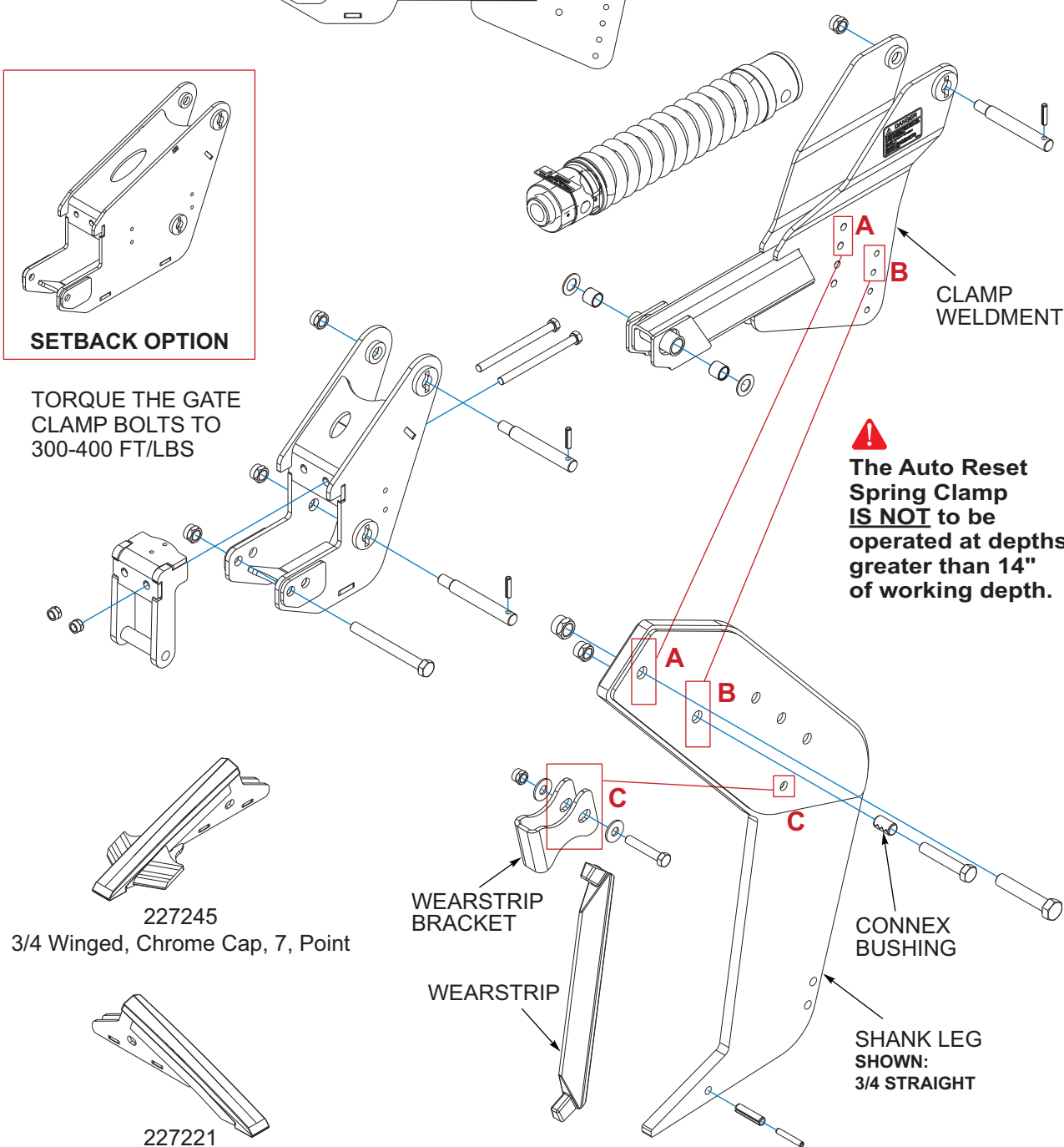

⚠
 The Auto Reset Spring Clamp **IS NOT** to be operated at depths greater than 14" of working depth.

- 227245
3/4 Winged, Chrome Cap, 7, Point
- 227221
3/4 Plain, Chrome Cap, 2, Point

Figure 3-4: Auto-Reset Shank Clamp (Spring)

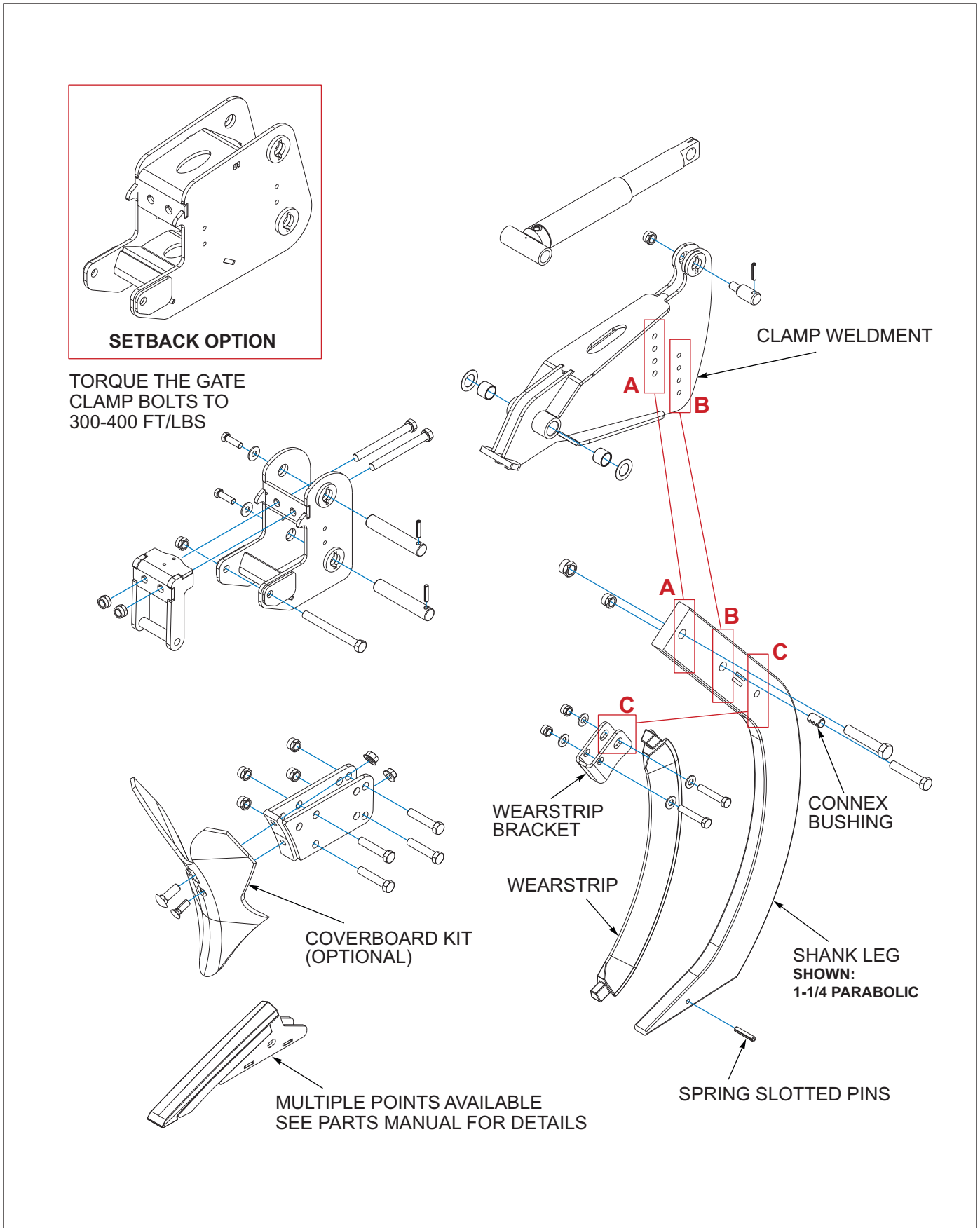

Figure 3-5: Auto-Reset Shank Clamp (Hydraulic)

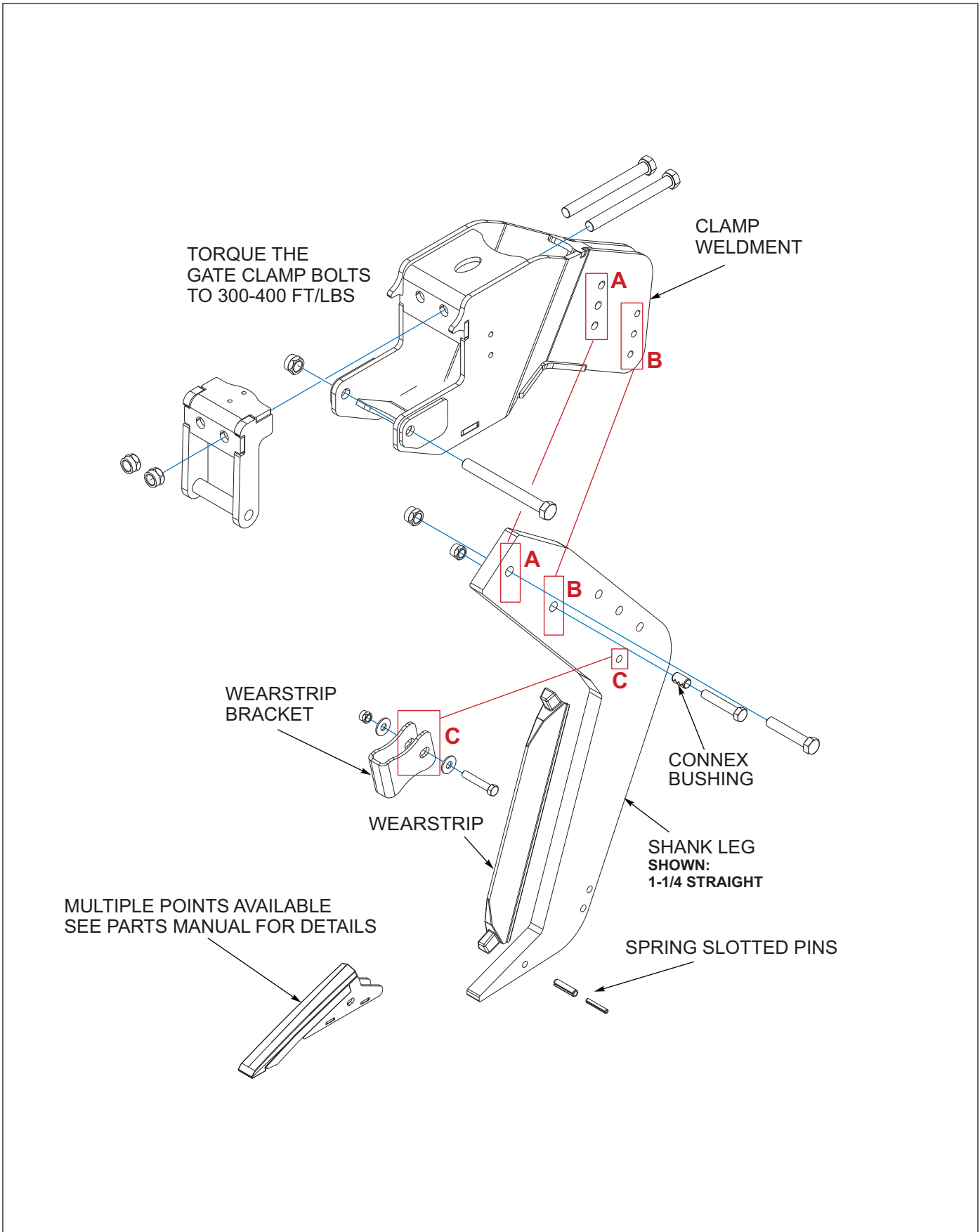

Figure 3-6: RSB Shank Clamp

Coverboard Installation

1. Insert four 1/2-13 x 2-1/2 bolts into the coverboard bracket before attaching the coverboard furrower. (See [Figure 3-5.](#)) Secure with 1/2-13 locknuts and tighten only so that locking portion of nut engages the thread. The customer will tighten these nuts after mounting to shank.
2. Tighten the 7/16-14 flange nut to the 7/16-14 x 1-1/4 plow bolt before tightening the 1/2-13 locknut to the 1/2-13 x 1-1/2 roundhead bolt. This is to ensure that the point of the coverboard furrower is pulled tightly against the bracket. Make sure that the plow bolt head is flush with the surface of the coverboard furrower. (See [Figure 3-7.](#)) This hardware should be tightened now.

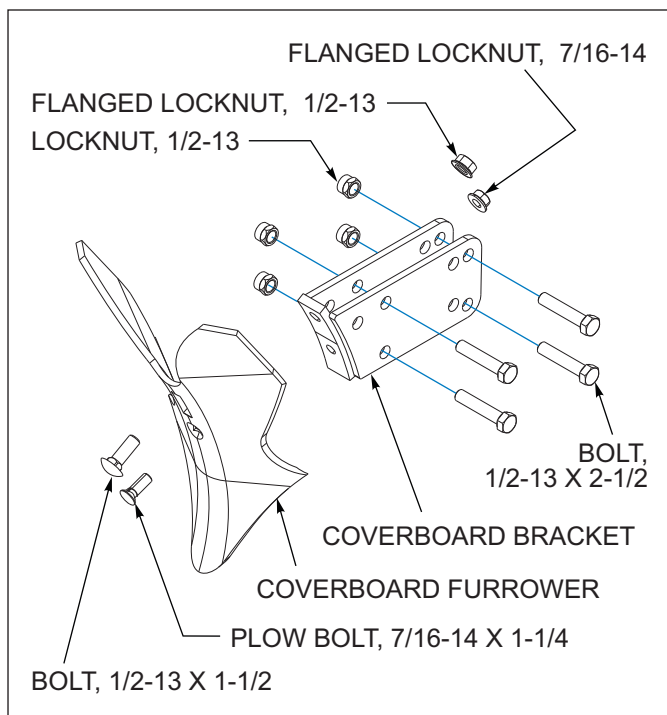

Figure 3-7: Coverboard Installation

Right Hand & Left Hand Couler Assemblies

1. Assemble couler adjustment tube to couler assembly using roll pins 1/2 x 4 and 5/16 x 4. Assemble the couler stop to the couler adjustment tube using 1/2 x 4 screw and nut. (See [Figure 3-8.](#))
2. Install the couler adjustment tube and couler assembly to the frame using the couler clamp tube, 4 u-bolts, clamp plate and 5/8-11 locknuts. Do not tighten nuts until the depth adjustment is completed.
3. Use adjustment pin and 3/16 hairpin to set desired depth. Tighten 5/8 locknuts on the u-bolts.
4. Attach couler blade to couler assembly using 1/2 x 1-1/2 screws and locknuts.

Gauge Wheel

1. The gauge wheel assembly comes fully assembled from the factory. (Horizontal Mount and Vertical Mount Options)
2. Attach the tire and wheel assembly to the hub and tighten the lug nuts to the proper torque as specified on [Page 2-3.](#)

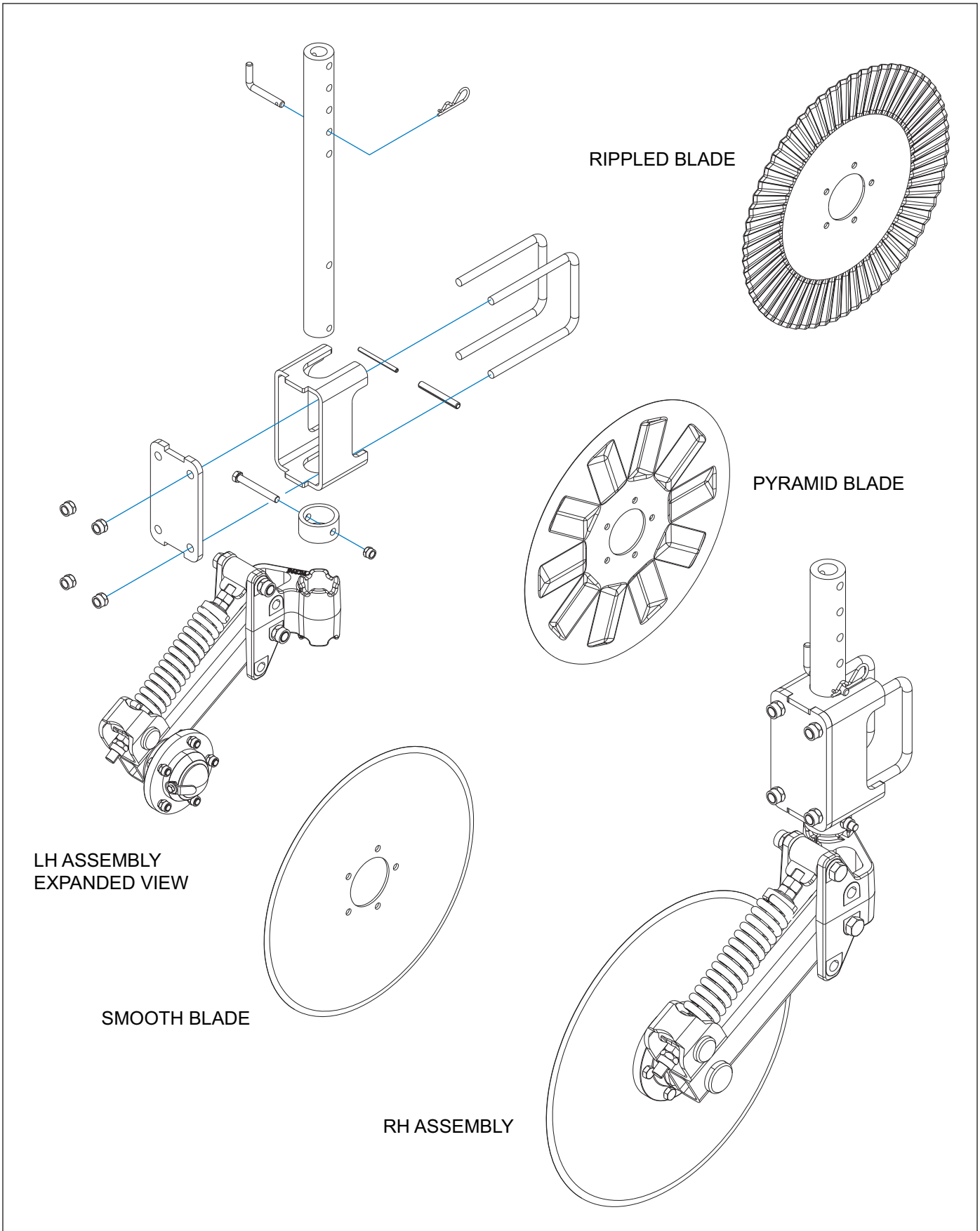

Figure 3-8: Coulters Assembly

GAUGE WHEEL ASSEMBLY - HORIZONTAL MOUNT

Used On All Units With
Odd Number Of Shanks Up To
And Including 9 And All Units Larger.

**LH GAUGE WHEEL -
EXPANDED VIEW**

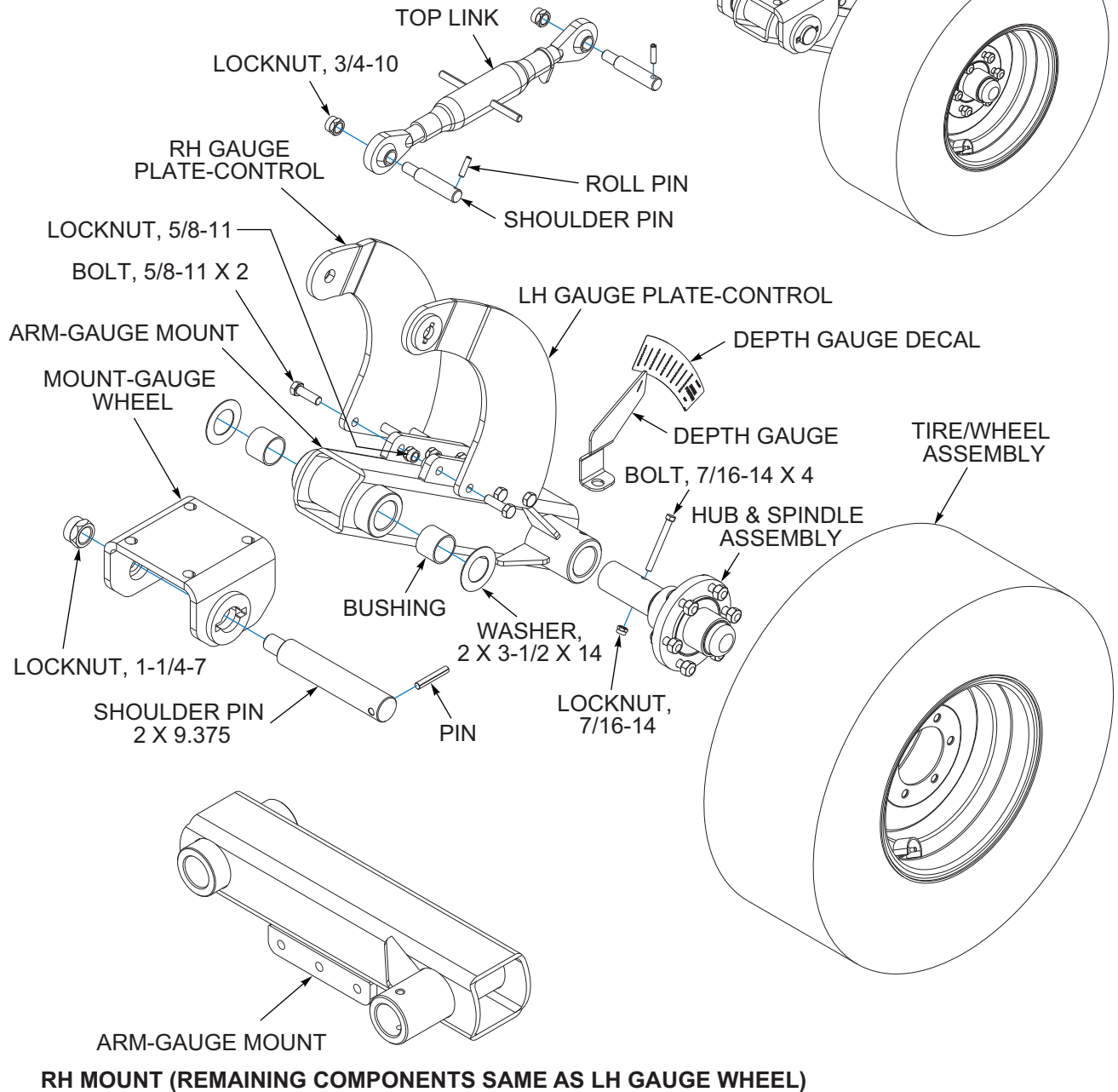

Figure 3-9: Gauge Wheel Assembly - Horizontal Mount

GAUGE WHEEL ASSEMBLY - VERTICAL MOUNT

Used On All Units With
Even Number Of Shanks 4 Through 8.

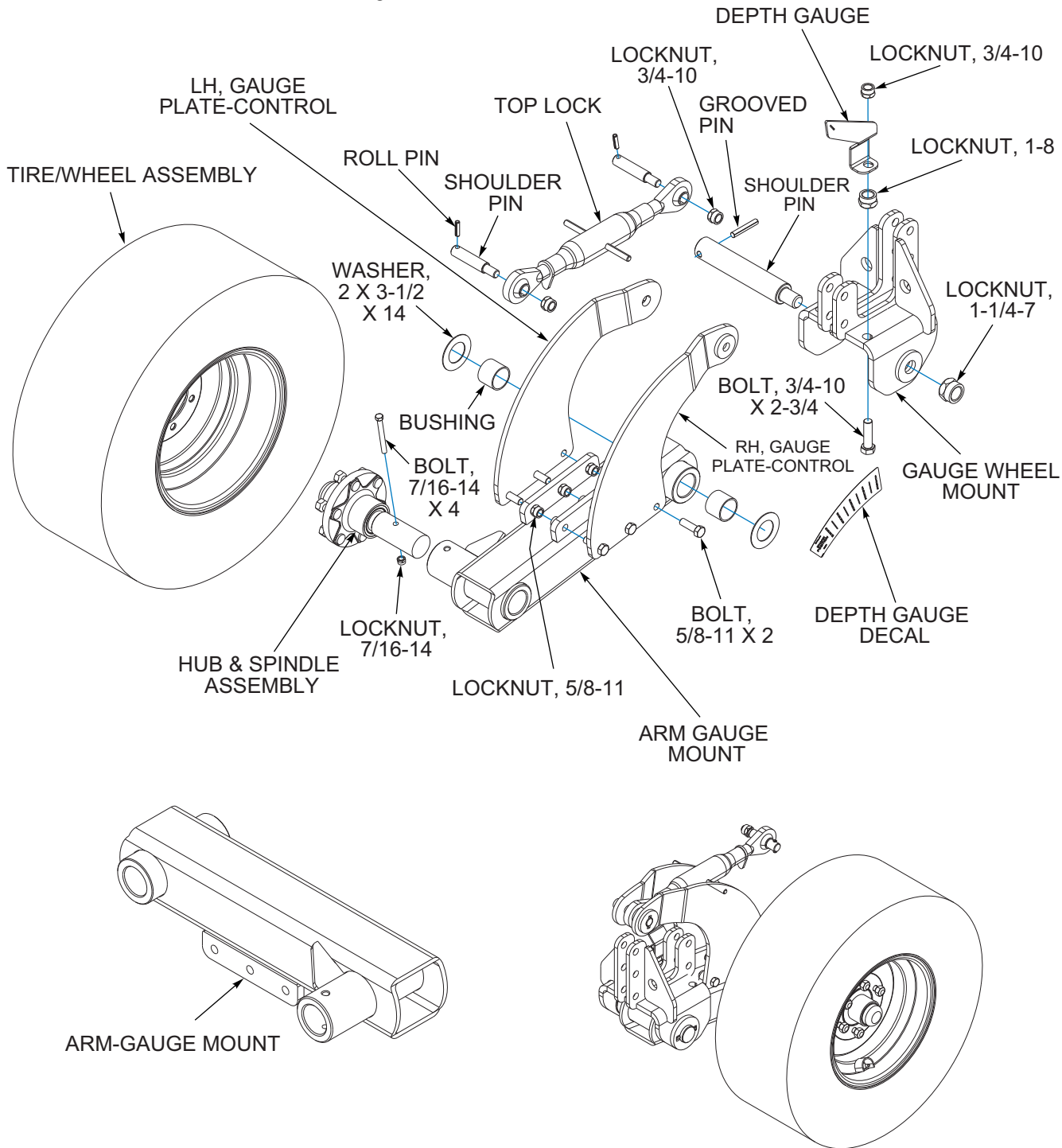

Figure 3-10: Gauge Wheel Assembly - Vertical Mount

Electrical Installation

1. Attach left and right (Amber) Light Mount Brackets to frame. (*See Figures 3-11 thru 3-12.*)
4 Shank: using 3-4-10 x 2 bolts and 3/4-10 lock nuts.
Rigid 5,6,7,8 Shank: using 3/8-16 x 1-1/4 bolts and 3/8-16 lock nuts.
Folding: using 1/2-13 x 1-1/2 bolts and 1/2-13 lock nuts
2. Attach Light Mount Reflector Bracket and ag Amber Lamps (LED) to light brackets using 1/4-20 x 1-1/2 bolts and 1/4-20 lock nuts.
3. Attach Bracket Holder and Light Mount Reflector Bracket to the front of the frame.
4. Attach (Red) Warning Lamp Brackets to frame using 1/2-13 x 1-1/2 bolt and 1/2-13 lock nuts. Install ag Red Lamps (LED) to brackets using 1/4-20 x 1-1/2 bolts and 1/4-20 lock nuts.
5. Attach Ag Flasher Control Module to frame using 1/4-20 x 2 bolts, 1/4W flat washers and 1/4-20 lock nuts. Be sure that the control module is set so that the 4 pin connector faces the right side of the machine.

IMPORTANT

Make sure lights are positioned for maximum visibility from the rear.

1. Install the LED Warning Light Harness to the frame. Connect 2 pin and 3 pin ends to each of the warning lights. Connect 6 pin to the ag flasher control module.
2. Attach 7 pin/4pin 120" harness to frame. Connect 4 pin end to the ag flasher control module.
3. Ensure that the harnesses are clear of any moving parts and secure the harnesses with tie wraps provided.
4. Install the stor-away holder bracket on bolt in coulter clamp plate and assemble harness stor-away to bracket with 1/4-20 x 3/4 hex head cap screws and hex lock nuts.

General Hydraulic Components - Hydraulic Reset Option

Figure 3-13 is provided as a general guideline for the components provided with the Hydraulic Reset Option. It is meant to assist with identifying components on the machine. Each machine size will use a specific quantity of each component during assembly. Please refer to Parts Manual for proper quantity per tool.

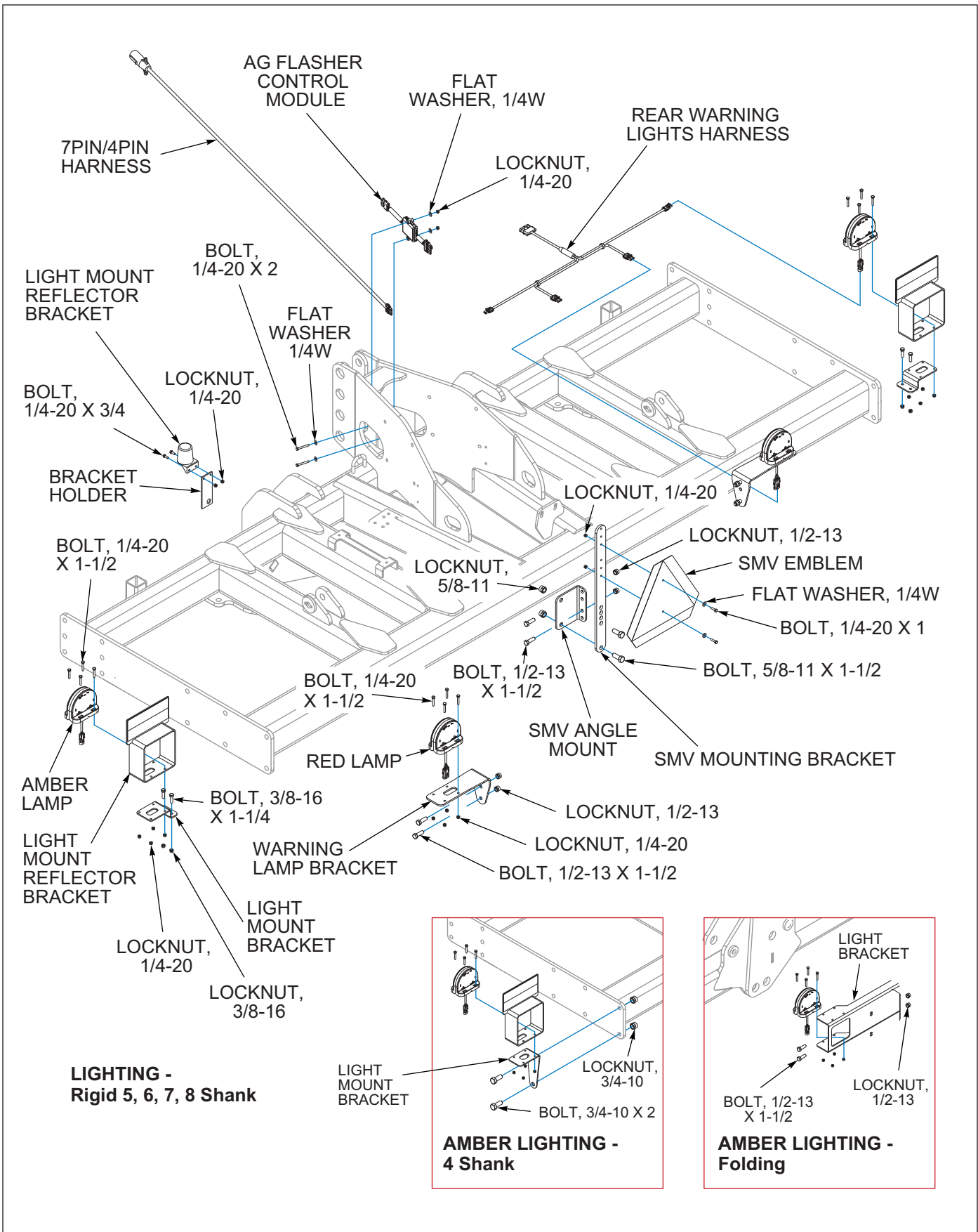

Figure 3-11: LED Light and SMV Bracket Installation

7-PIN CONN.	4-PIN TOWER	CIRCUIT	WIRE COLOR
1	D	GROUND	GROUND
2	-	WORK LAMPS	BLACK ●
3	B	LEFT FLASHING & TURN	YELLOW ●
4	-	STOP LAMPS	RED ●
5	A	RIGHT FLASHING & TURN	GREEN ●
6	C	TAIL LAMPS	BROWN ●
7	-	SWITCHED POWER (12 V)	BLUE ●

LED WARNING LIGHT HARNESS - WIRING CHART

	1	2	3	4	5
	2-PIN TOWER	3-PIN TOWER	6-PIN SHROUD	3-PIN TOWER	2-PIN TOWER
● BLACK LEFT TURN			A	C	
● WHITE GROUND	A	A	B	A	A
● BROWN TAIL LIGHT		B	C	B	
● YELLOW LEFT TURN			D		B
● GREEN RIGHT TURN	B		E		
● RED RIGHT TURN		C	F		

7 PIN/4PIN LIGHT HARNESS - WIRING CHART

Figure 3-12: LED Light and SMV Harness Wire Designations

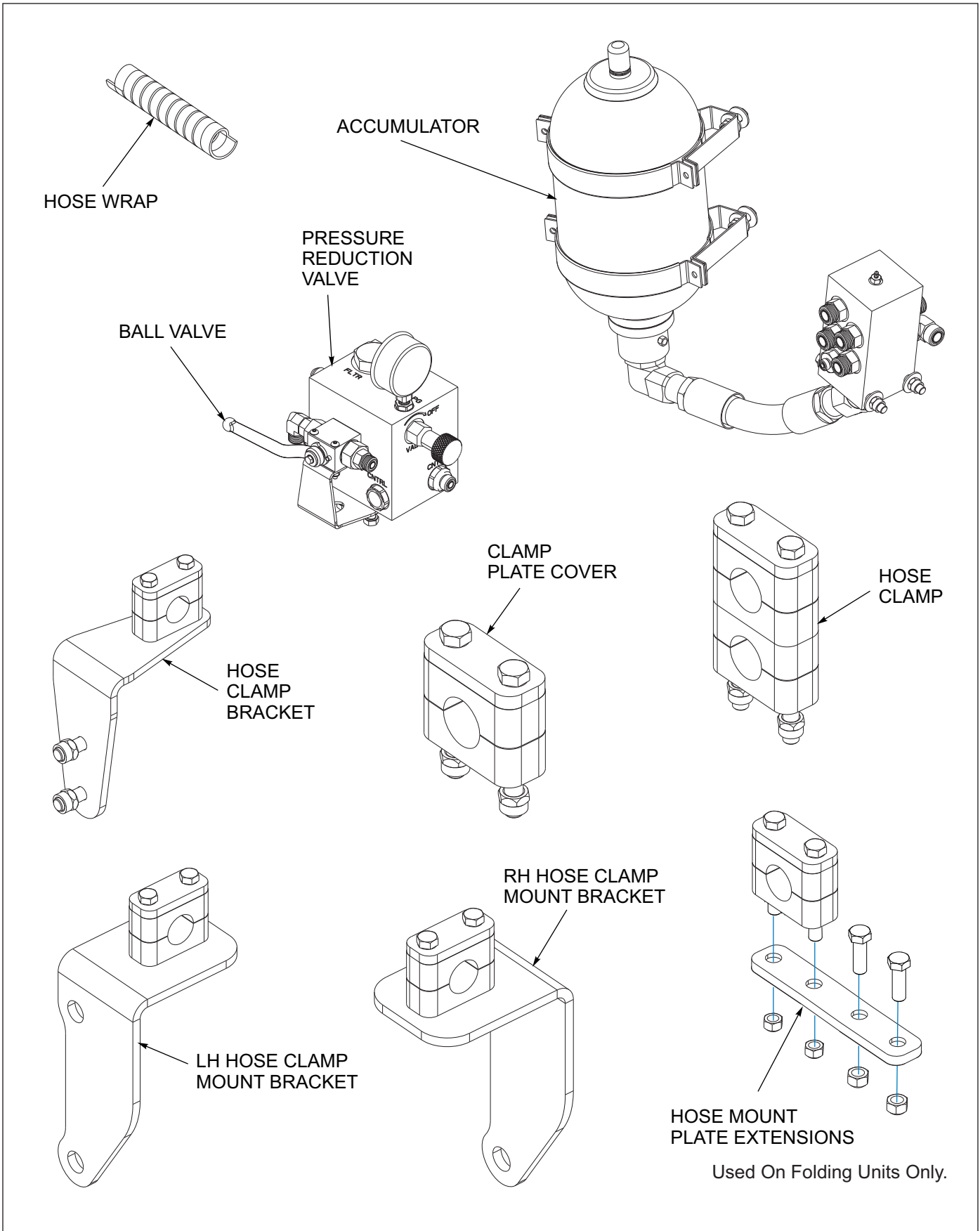

Figure 3-13: Hydraulic Reset Option - General Components

Closer Platform (Option) and Features

The Closer Platform allows the user to mount 5 different features: Closer Wheel, Flat Bar Basket 20", Closer Disc, Crumbler Wheel or Packer Reel.

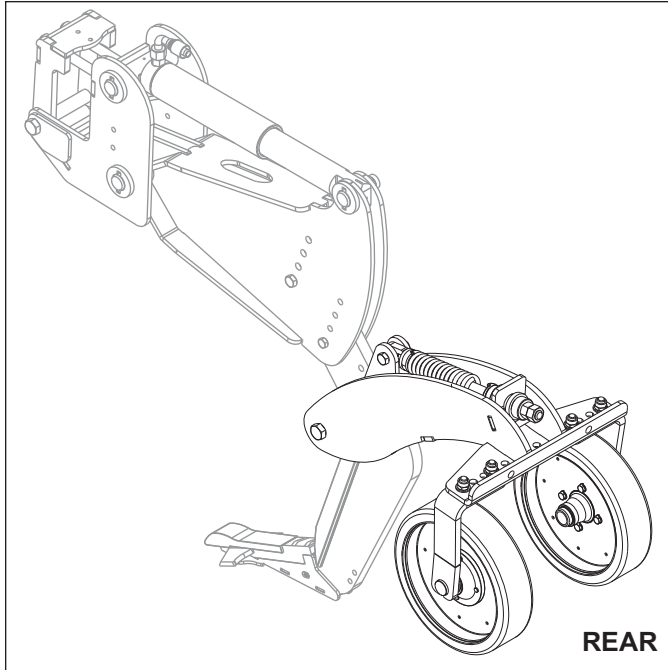

Figure 3-14: Closer Platform Assembled with Closer Wheels

NOTE

When setting up the Zone Commander to operate at 14" or less depth, position the Closer Pivot Mount in the lower two holes of the shank.

When setting up the Zone Commander to operate at 14" or greater depth, position the Closer Pivot Mount in the upper two holes of the shank.

Closer Platform Spring Set Up Instructions

- For operating depths of 14" or less, place both spacers between the Rear Spring Keeper and the Rod Glide.
- For operating depths of 14" to 17", place one of the spacers between the Rear Spring Keeper and the Rod Glide. Place the other spacer between the washer and the locknuts.
- For operating depths of 17" or greater, place both spacers between the washer and the locknuts.

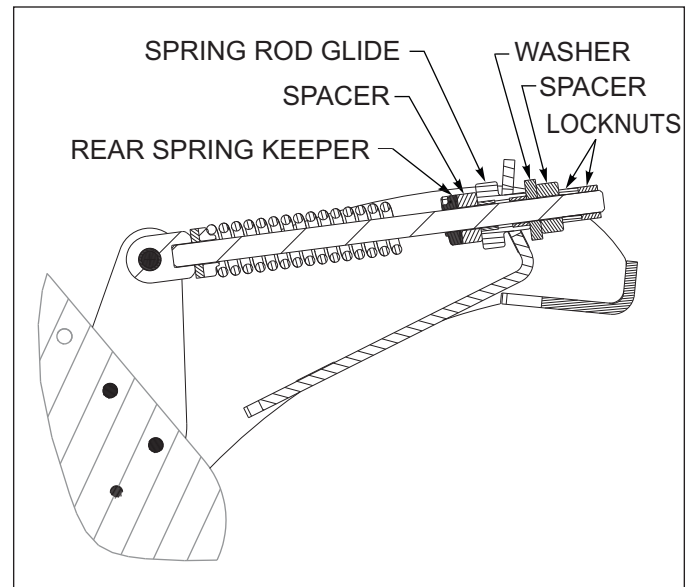

Figure 3-15: Closer Platform Spring Setup

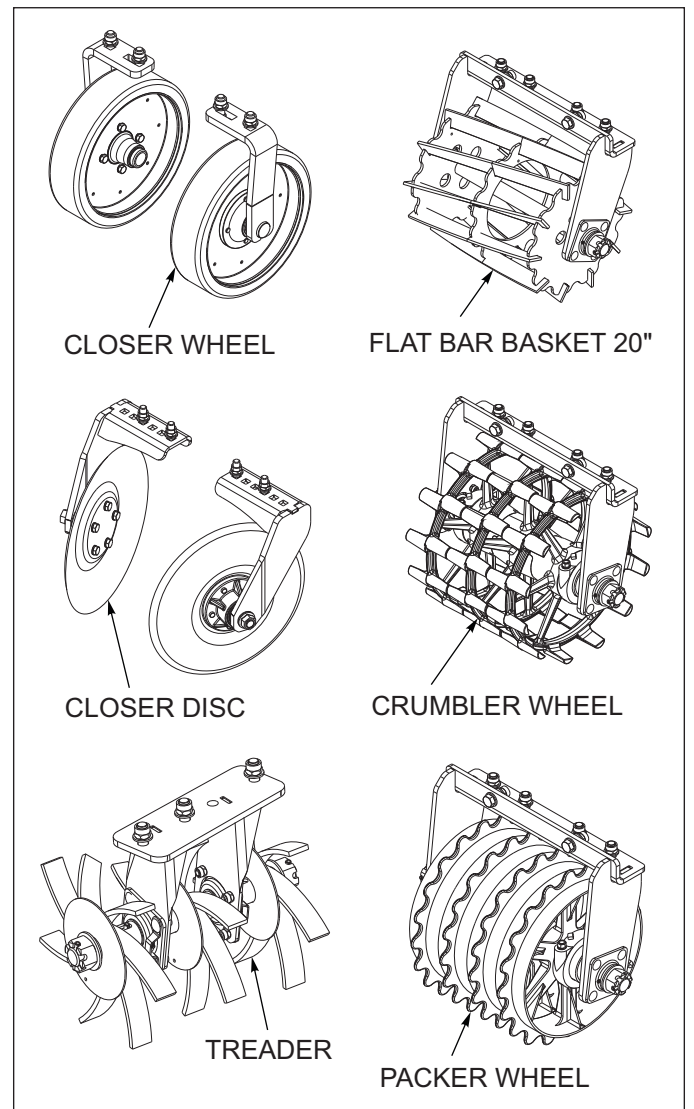

Figure 3-16: Closer Platform Finishing Options

Operation and Maintenance

**DANGER**

Coultter blades are sharp. Do not allow coultters to roll over or fall on any part of the body. Do not allow wrenches to slip when working near coultter blades. Do not climb over machine above coultter blades. Failure to stay clear of coultter blade edges may result in serious personal injury or death.

**DANGER**

Do not attempt to disassemble spring assemblies. The spring assembly contains significant stored energy and is capable of releasing enough force to cause serious injury or death.

**DANGER**

Do not attempt to manually reset a shank assembly or straighten a bent shank mount. Contact a Landoll dealer or Landoll Company, LLC immediately for assistance.

**DANGER**

Never allow anyone to ride on the Zone Commander at any time. Allowing a person to ride on the Zone Commander may result in serious personal injury or death of that person.

**WARNING**

All hydraulically elevated equipment must be locked out or lowered to the ground when servicing or when equipment is idle, to prevent accidental lowering. Failure to take measures to prevent accidental lowering may result in serious personal injury.

**CAUTION**

Whenever transporting farm implements on public roads, it is the responsibility of the operator to abide by state and local laws concerning wide loads, speed, safety emblems, and safety lighting equipment. Drive at safe speeds, particularly when rounding corners, crossing rough ground and on hillsides, to prevent tipping.

Tractor Preparation

The 2512 Series Rigid and The Folding Zone Commanders up to and thru the 2512F-9 can be used on tractors with CAT IVN hitches. For Zone Commanders larger than the 2512F-9 it is recommended to be mounted on a Caddy. All 2512 and 2512F Zone Commanders can be mounted onto a Caddy. Before attaching the Zone Commander, prepare the tractor as follows:

- a. The rear tractor tires should be inflated equally and ballast added according to the tractor operator's manual.
- b. For mounted type models, install front end weights as needed on tractor to maintain stability.

Zone Commander Operation

1. Before operating the Zone Commander, inspect it to be sure it is in good operating condition.
2. Replace badly worn or missing parts.
3. While the machine is new, bolt tightness should be checked after a few hours of operation. Tighten any loose nuts or cap screws. Check the gauge wheel lug bolts daily.
4. Check the gauge wheel tire inflation. All tires should be equally inflated to avoid side draft.

Hydraulic Accumulator Operation

The 2512 Rigid and Folding Zone Commander may be equipped with the Hydraulic Reset Option. The Hydraulic Reset Option utilizes a factory-charge accumulator. The accumulator needs to carry an additional hydraulic charge to do field work.

The hydraulic charge needs to be greater in magnitude than the nitrogen pre-charge to create an oil reserve within the accumulator to maintain working pressure in the event of a small loss of oil from the system or a change in ambient temperature.

The Zone Commander does not need to be connected to the tractor during field operation but connecting the lines to the tractor will keep them out of harms way.

The ball valve between the pressure reduction valve manifold and the machine system needs to be turned "OFF" during field operation. The ball valve should only be opened to 1.) check the system operating pressure present, and 2.) adjust the system pressure if it is too high or too low (below 2,000 psi).

The pressure reduction valve is pre-set at the factory to have a hydraulic output of 2,000 psi. The pressure reduction valve will increase the hydraulic pressure of the system to 2,000 psi if it is less than 2,000 psi and will allow oil to pass back to the tractor if the system pressure is higher than 2,000 psi thereby reducing the system pressure. The pressure gauge will not monitor the system pressure unless the ball valve is opened, but the valve should remain in the "OFF" position unless the operating pressure is being checked or adjusted.

To Charge The Accumulator:

1. Connect the pressure and return lines to the pressure reduction valve manifold to the tractor.
2. Activate the tractor circuit connected to the pressure reduction manifold. If the pressure immediately reaches 3,000psi the connections needs to be reversed.
3. Open the ball valve on the 2512 (align with the hydraulic lines entering and leaving the valve manifold). Monitor the pressure gauge on the pressure reduction valve manifold and **CLOSE** the valve when the pressure reaches 2,000psi
4. Once the accumulator is charged to 2,000psi there should be no need to recharge the system except for ambient temperature changes or leaks in the system.

NOTE

If the system continuously loses pressure, contact Landoll Company, LLC and request to speak with a technician.



DANGER

Do not discharge or attempt to discharge the accumulator. Do not adjust or remove any fittings on the accumulator. Failure to heed or comply to this warning will result in serious injury or death.

Attaching to Three-Point Hitch

1. Carefully back the tractor into place.
2. Attach the Zone Commander to the tractor.
3. For tractors equipped with Quick Hitches:
 - a. Attach Quick Hitch to the Zone Commander.
 - b. Raise and make sure lower pin locks are secured.
 - c. Raise the parking stand and pin in fully up position.
 - d. When disconnecting the Zone Commander, adjust stands to leave the tool bar tilted slightly forward. This will permit easier disconnecting and reattaching.
4. For tractors not equipped with Quick Hitch:
 - a. Attach lower lift arms of the tractor to the Zone Commander utilizing appropriate pins. 2512 Rigid Model come with either Category IIIN, CAT III, and CAT IVN. 2512 Folding Models come with CAT IVN ONLY. *(See Figure 4-1)*
 - b. Attach top link after connecting lower lift arms. Raise parking stands into clamps or remove them on rigid models. For all folding models the jack stands must be removed from the machine during transport. When disconnecting, place stand so that the Zone Commander is stable.
5. Reinstall the stabilizer bars or sway blocks before transporting.



CAUTION

Do not move tractor without making sure top hitch is connected to tractor.

Attaching to Caddy

If you will be attaching the Zone Commander to a Caddy:

1. Carefully back the Caddy up to the Zone Commander.
2. Attach the lower links of the Caddy to the Zone Commander first.
3. When the lower links have been secured, extend or retract the upper link of the Caddy using the hydraulic upper link. Attach the upper link of the caddy to the Zone Commander.

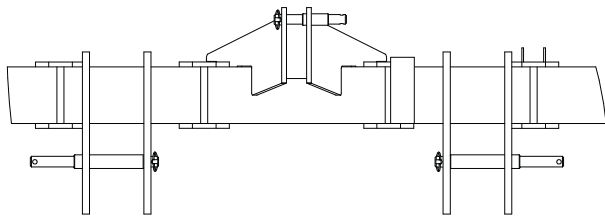

CAT II HITCH

USED WITH 3, 4, & 5 NARROW FRAMES

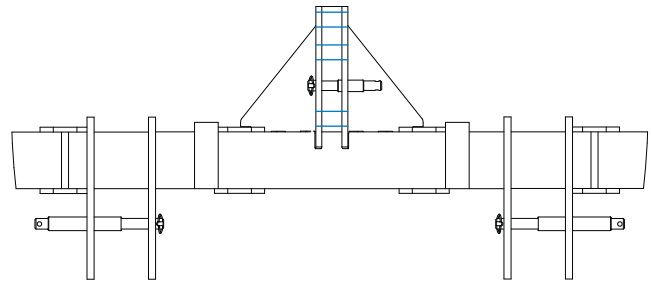

CAT III NARROW HITCH

USED WITH 7, 8, & 9 FOLDING FRAMES
&
4, 5, 6, & 7 STANDARD FRAMES

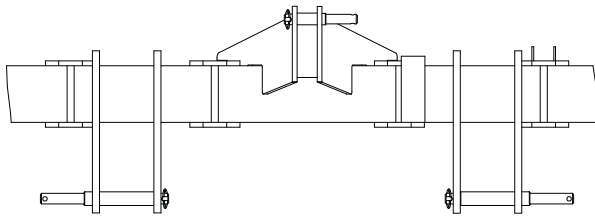

CAT III HITCH

USED WITH 3, 4, & 5 NARROW FRAMES

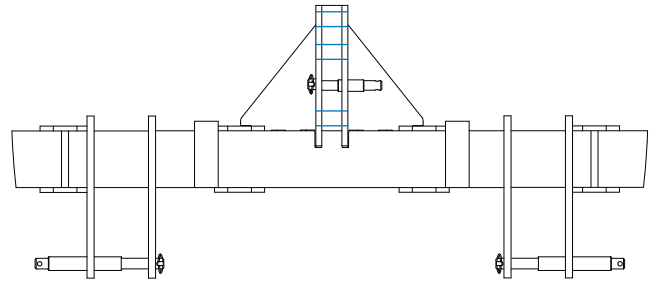

CAT III HITCH

USED WITH 7, 8, & 9 FOLDING FRAMES
&
4, 5, 6, & 7 STANDARD FRAMES

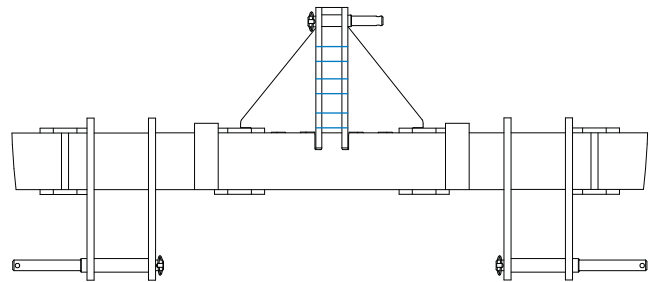

CAT IV NARROW HITCH

USED WITH 7, 8, & 9 FOLDING FRAMES
&
4, 5, 6, & 7 STANDARD FRAMES

Figure 4-1: 3 Point Hitch Setup

Hydraulic Fold System

1. The Zone Commander is equipped with a hydraulic fold system to raise and lower the wing frames for narrow transport.
2. Be sure the system is fully charged with hydraulic oil before attempting to fold/unfold the unit. Air in the system can allow uncontrolled dropping of the wing frames causing serious personal injury or machine damage. The system needs to be charged with oil initially and any time the system has been opened for repair such as cylinder, hose or fitting replacement/repair.
3. To charge the system, carefully hitch the Zone Commander to the tractor. Check the tractor hydraulic fluid level to make sure it is full of the manufacturer's recommended hydraulic fluid. Connect the cylinder hoses to the tractor and fully extend and retract the cylinders several times.

NOTE

The Rigid Shear Bolt (RSB) Shank Clamp and the Auto-Reset Hydraulic Shank Clamp fold 180° degrees. The Auto-Rest Spring Shank Clamp does not fold to 180° degrees.

The cylinder rod travel should be smooth and positive when all air has been purged from the system. Due to large amounts of hydraulic oil required, recheck the tractor fluid level to make sure it is within proper operating limits.

4. The hydraulic fold system is equipped with restrictors in the rod end of cylinders to prevent uncontrolled falling of wing frames when unfolding. Removal or improper assembly of these restrictors can cause the machine to fold improperly and result in serious machine damage.



WARNING

Escaping hydraulic fluid can cause serious personal injury. Relieve system pressure before repairing, adjusting, or disconnecting. Wear proper hand and eye protection when searching for leaks. Use cardboard instead of hands. (See Figure 4-2.) Keep all components (cylinders, hoses, fittings etc.) in good repair.

5. To fold/unfold the wing frames, find a level area large enough to accommodate the Zone Commander when it is fully unfolded. The tractor should be stopped and not moving with the unit fully raised.
6. To lock the Wing Assembly down, remove the pin from the unlocked position and into the locking position. *See Figure 4-2.*



WARNING

The wing fold hydraulic system MUST be operated in float once the wings are unfolded OR the wings MUST be locked down. Failure to do so may result in wing fold cylinder damage. See Figure 4-2.

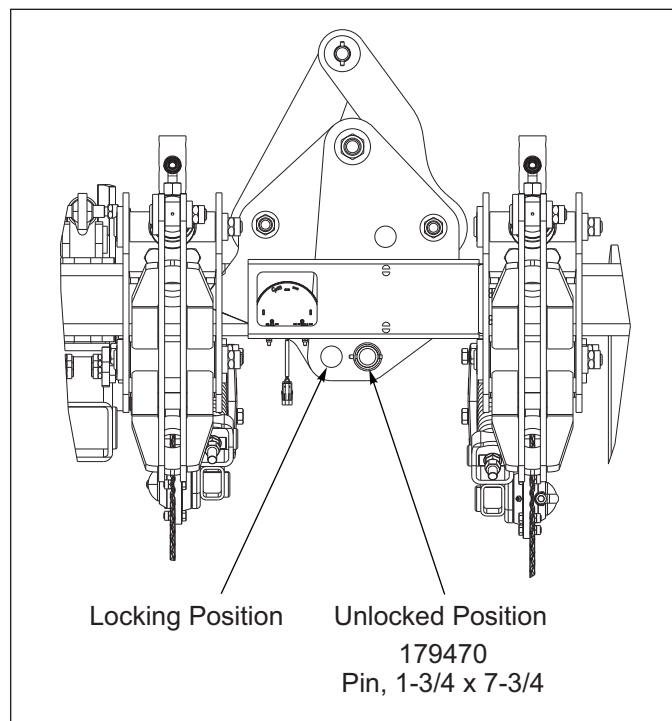

Figure 4-2: Folding Frame Wing Lock

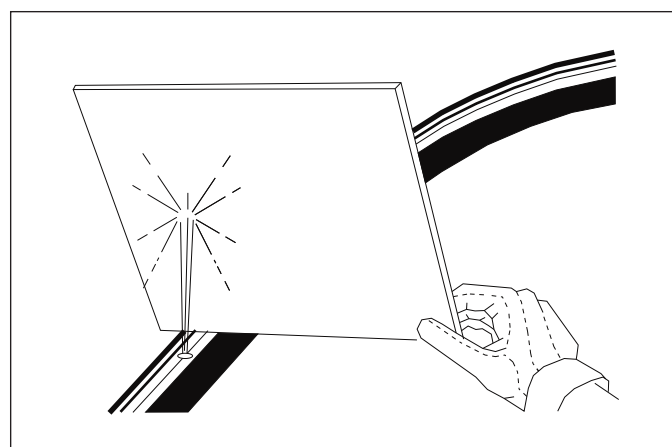

Figure 4-3: Hydraulic Leak Detection

Field Operation - Three Point Hitch Type

1. Lower the Zone Commander to the ground and pull it a few feet at the approximate desired depth.
2. Check for front-to-rear levelness. Level the frame by adjusting the three-point hitch top arm until the frame is level relative to the ground.
3. Set the depth by adjusting the gauge wheels. For stability, it is important that the gauge wheels are always in contact with the soil. Adjust the gauge wheels as follows:
 - a. Loosen the keeper nut on the adjustable top link.
 - b. Shorten the top link to shallow up the Zone Commander, lengthen the link to allow the Zone Commander to run deeper.
 - c. Snug up the top link keeper nut.
4. Always lift the Zone Commander completely out of the ground before turning or backing to prevent shank or coulter damage or damage to their respective mounting brackets.
5. Reduce speed at field ends, raise the Zone Commander out of the ground, and assist turning by using the wheel brakes, if necessary.
6. After a few hours of initial operation, check all cap screws for tightness. Tighten any loose cap screws.
7. Coulters should be adjusted to operate only deep enough to be in firm soil and cut the residue. Generally, the harder the soil, the less pressure should be used on the coulters. Adjust the single coulters by loosening the coulter mount U-bolts, sliding the coulter up or down as needed. Re-tighten the coulter mount making sure the coulter standard tube is square with the Zone Commander frame.

Wheel Bearing Maintenance

1. Check wheel bearings and coulter bearings occasionally for excessive end play. To correctly replace the wheel bearings:
2. Place the frame on blocks or stands sufficient to lift the tire clear of the ground.
3. Remove the hub cap, cotter pin, slotted nut, and washer.
4. Remove the hub. Clean and inspect the bearings and hub cavity. Replace any worn or defective parts.
5. Repack the bearings using a high-quality wheel bearing grease.
6. Replace the hub with a new seal and inner bearing in place.
7. Install the outer bearing cone, washer, and slotted nut.

8. Tighten the slotted nut while rotating the hub until there is a slight resistance to wheel rotation. Back the slotted nut off one notch until the wheel rotates freely without end play.
9. Install a new cotter pin and the hub cap.
10. Wheel bearing maintenance should be performed at the beginning of every season of use.

Coulter Spring Adjustment

No spring adjustment is necessary on the coulters. All adjustments were made before shipping at the factory. Initial operating force to move coulter upwards is 540 pounds. The preload has proved to be more than adequate for most conditions.



CAUTION

Any attempt to make coulter force greater than factory setting may contribute to premature failure of parts and warranty shall be null and void.

Lubrication

IMPORTANT

Items with grease zerks are listed in the illustrated parts book.

1. Grease coulter hub and swivel mount casting after twenty hours of use.

Storage

1. The service life of the Zone Commander will be extended by proper off-season storage practices. Before storing, complete the following procedures:
2. Completely clean the unit.
3. Inspect the machine for worn or defective parts. Replace parts as needed to avoid delays the following season.
4. Repaint all areas where the original paint film is worn off.
5. Grease all exposed metal surfaces of shanks, points, and coulters.
6. Lubricate as suggested in [“Lubrication” on page 4-6](#).
7. Store the unit in a shed or under a tarpaulin to protect it from the weather. The ground tools and tires should rest on a board or other device to keep them out of the soil.

Troubleshooting Guide

The Troubleshooting Guide, shown below, is included to help you quickly locate problems that can happen using your 2512 Series Rigid & Folding Zone Commander. Follow all safety precautions stated in the previous sections when making any adjustments to your machine.

PROBLEM	PROBABLE CAUSE	SOLUTION
SPIKES DO NOT PENETRATE TO DESIRED DEPTH	Coulters set too deep	Adjust coulters up, to just run in firm soil, to cut residue.
	Spikes worn back	Replaces spikes
	Lower hitch arms in lower holes of pull bracket	Move hitch arms to upper hole in pull brackets.
	Implement not level	Adjust top 3-point link.
UNIT BOUNCES OR NOT WORKING AT UNIFORM DEPTH	Gauge wheels not set at correct depth	Adjust gauge wheels to correct depth. Gauge wheels, not the 3-point hitch, should carry the load.
	Gauge wheels not set at correct depth	Adjust all gauge wheels to same depth.
	Tire pressure not equal	Inflate all tires to the same pressure.
	Lower hitch arms not set to same height	Measure lower hitch arms and adjust to uniform length.
RESIDUE HANGS ON SHANKS	Coulter not set deep enough	Adjust coulter down to run in firm soil, to cut residue.
	Gauge wheel too close to shank	Position gauge wheel on frame for maximum clearance to shanks.
	Coulter not aligned	Check coulter alignment on front bar.
	Soil too wet causing hairpinning of residue	Let soil dry.

Document Control Revision Log:

Date	Form #	Improvement(s): Description and Comments
05/2020	F-1049	Initial Release
12/2020	F-1049-1220	Added: Folding Shank Mounting Dimensions ECN 46468 - Added Depth Gauge and Decal, Added Hose Mount Plate Extension ECN 46650 - Updated Warning Light Bracket, Gusset-Frame Braces Added: Closer Platform and Features
01/2021	F-1049-0121	ECN 46837 - Added Rear Jack Option and Decals
04/2021	F-1049-0421	ECN 46857 - Add Treader Option, Update 3/4 Straight Leg Shank
12/2021	F-1049-1221	ECN 47144 - Changes to Front Jack Mount ECN 47623 - Revisions to Parabolic Shank 1-1/4 ECN 47679 - Changes to Parabolic Wear Guard Keeper and Parabolic Shank Hardware
01/2022	F-1049-0122	ECN 47822 - Add Shank Hardware Kit ECN 47824 - Revised Parabolic Keeper-Wear Guard, Clamp Designs/Torque Values



Intertek

Equipment from Landoll Company, LLC is built to exacting standards ensured by ISO 9001 registration at all Landoll manufacturing facilities.

2512 Zone Commander Operators Manual

Re-Order Part Number F-1049

LANDOLL COMPANY, LLC

1900 North Street

Marysville, Kansas 66508

(785) 562-5381

800-428-5655 ~ WWW.LANDOLL.COM



Copyright 2022. Landoll Company, LLC

“All rights reserved, including the right to reproduce this material or portions thereof in any form.”

