



*Doing Our Best to Provide You the Best*

8E000048, Rev AC  
7/26/18

## COMBINE GRAIN TANK EXTENSION TIP-UP KIT

9E000052 - MZ315C Tip-up Kit

**FITS CASE IH 7120,7230,7240,7250  
w/ POWER FOLD COVER & 24" PANELS**

**PLACE IN COMBINE CAB AFTER ASSEMBLY  
FOR FUTURE REFERENCE.**



**FOR USE ON COMBINES WITH  
POWER FOLD COVER ONLY**

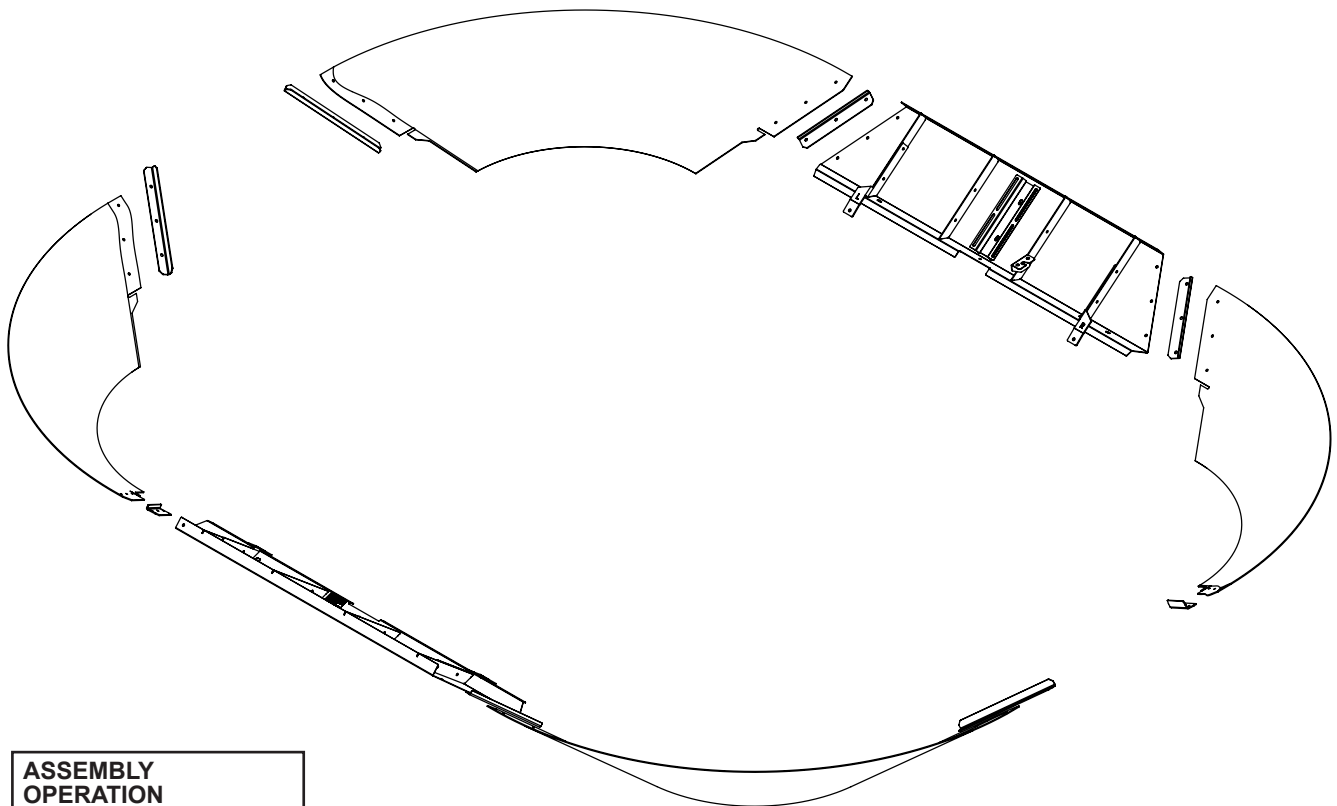

**ASSEMBLY  
OPERATION  
REPLACEMENT PARTS**

**OPERATOR MANUAL**

## INTRODUCTION

Thank you for purchasing a Demco grain tank extension Tip-Up kit. Proper care and use will result in many years of service.



**WARNING:** TO AVOID PERSONAL INJURY OR DEATH, OBSERVE THE FOLLOWING INSTRUCTIONS:

Ensure that anyone present is clear before applying power to any machinery used in conjunction with a Demco grain tank extension.

Never allow anyone in or near the grain tank of a combine during loading or unloading of grain. The accumulation of grain is dangerous and can cause entrapment, resulting in serious injury or death by suffocation.

Adding a Demco Bin Extension or Tip-Up increases the overall height of your combine. Use caution when operating around trees, buildings, power lines, and when approaching bridges and over passes. Pay attention to height restrictions.

Do not exceed advertised maximum capacity of a Demco grain tank extension.

Beware of low power lines and other obstructions.

## GENERAL INFORMATION

1. Read assembly instructions carefully. Study assembly procedures and all illustrations before you begin assembly. Note which parts are used in each step. This unit must be assembled in proper sequence or complications will result.
2. When placing a parts order, refer to this manual for proper part numbers and place order by **PART NO. and DESCRIPTION.**
3. Whenever terms “**LEFT**” and “**RIGHT**” are used in this manual it means from a position behind combine and facing forward.

## Table of Contents

General information.....	2
Safety, Signal Words.....	3
Product Safety Guidelines.....	4
Product Disclaimer.....	4
Safety Sign Locations.....	5
Safety Sign Care.....	5
Parts Breakdown.....	6
Assembly Instructions.....	7-9
GPS Bracket.....	10
Handrail Installation.....	11

## SAFETY

**TAKE NOTE! THIS SAFETY ALERT SYMBOL FOUND THROUGHOUT THIS MANUAL IS USED TO CALL YOUR ATTENTION TO INSTRUCTIONS INVOLVING YOUR PERSONAL SAFETY AND SAFETY OF OTHERS. FAILURE TO FOLLOW THESE INSTRUCTIONS CAN RESULT IN INJURY OR DEATH!**



**THIS SYMBOL MEANS  
ATTENTION  
BECOME ALERT  
YOUR SAFETY IS INVOLVED!**

### **SIGNAL WORDS**

Note use of following signal words **DANGER**, **WARNING**, and **CAUTION** with safety messages. The appropriate signal word for each has been selected using the following guidelines:

**DANGER:** Indicates an imminently hazardous situation that, if not avoided, will result in death or serious injury. This signal word is to be limited to most extreme situations typically for machine components which, for functional purposes, cannot be guarded.

**WARNING:** Indicates a potentially hazardous situation that, if not avoided, could result in death or serious injury, and includes hazards that are exposed when guards are removed. It may also be used to alert against unsafe practices.

**CAUTION:** Indicates a potentially hazardous situation that, if not avoided, may result in minor or moderate injury. It may also be used to alert against unsafe practices.



## **PRODUCT SAFETY GUIDELINES**

Every year many accidents occur which could have been avoided by a few seconds of thought and a more careful approach to handling equipment. You, the operator, can avoid many accidents by observing the following precautions in this section. To avoid personal injury, study the following precautions and insist those working with you, or you yourself, follow them.

Replace any caution, warning, danger or instruction safety decal that is not readable or is missing. Location of such decals is indicated in this booklet.

Review safety instructions with all users annually.

Operator should be a responsible adult. **DO NOT ALLOW PERSONS TO OPERATE OR ASSEMBLE THIS UNIT UNTIL THEY HAVE DEVELOPED A THOROUGH UNDERSTANDING OF SAFETY PRECAUTIONS AND HOW IT WORKS.**

Do not paint over, remove, or deface any safety signs or warning decals on your equipment. Observe all safety signs and practice instructions on them.

Never exceed limits of a piece of machinery. If its ability to do a job, or to do so safely is in question **DON'T TRY IT.**

Adding a Demco Bin Extension or Tip-Up increases the overall height of your combine. Use caution when operating around trees, buildings, power lines, and when approaching bridges and over passes. Pay attention to height restrictions.

Fold and secure (if needed) the grain tank extension panels when transporting the combine to avoid contact with low power lines and other obstructions.

Ensure that any additional bracing and safety equipment have been installed according to this manual. (Some models do not require additional bracing or safety equipment)

Never exceed the maximum advertised capacity of the grain tank extension. By doing so you risk damage to the grain tank extension and combine.

## **PRODUCT DISCLAIMER**

Increasing the grain tank capacity of any combine by use of this product is at the discretion of the owner. Increasing the grain holding capacity of any combine may affect the structural aspects of the combine as well as drive line components and tires. Although Demco has included additional support bracing on selected models, it does not assume liabilities, or make any warranties pertaining to the structural stability or performance of any combine. See the combine owners/operators manual for additional combine specifications and safety information not listed in this manual.



## **SAFETY SIGN LOCATIONS**

Types of safety sign and locations on equipment are shown in the illustration below. Good safety requires that you familiarize yourself with various safety signs, type of warning, and area or particular function related to that area, that requires your SAFETY AWARENESS.

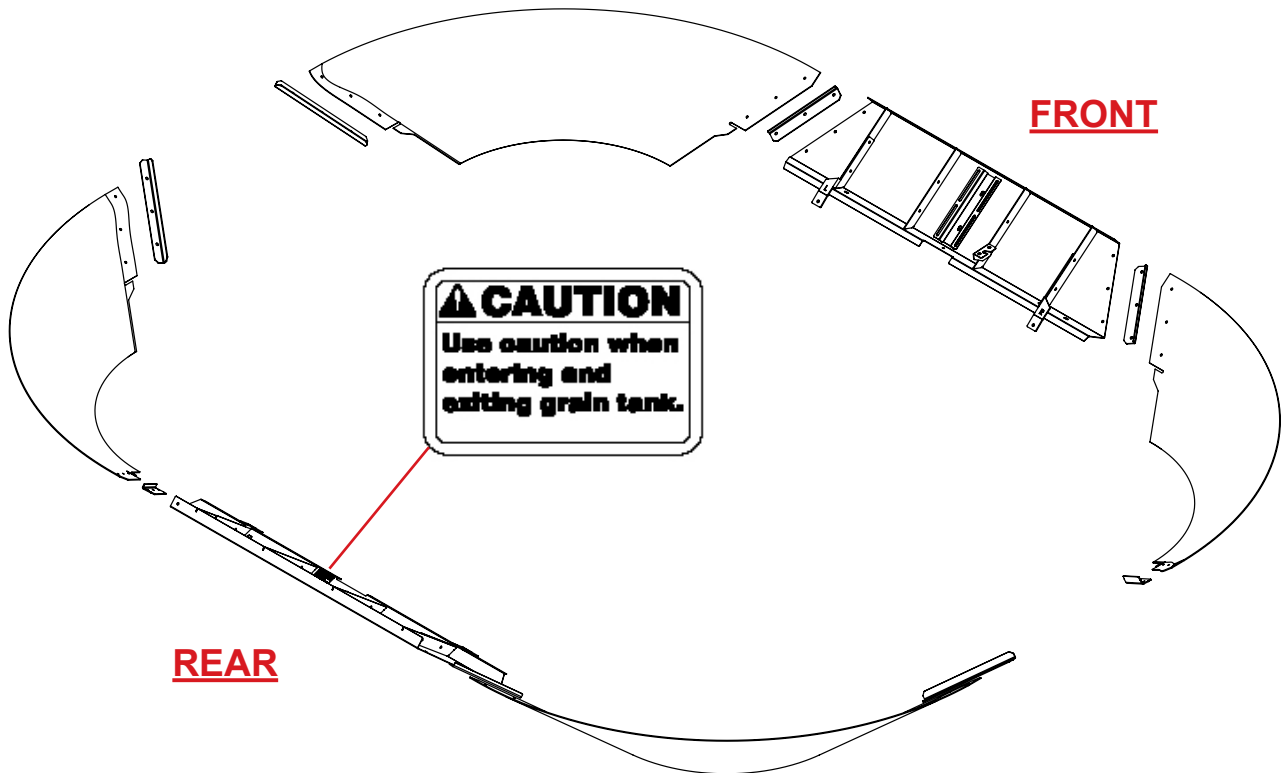

## **SAFETY SIGN CARE**

- Keep safety signs clean and legible at all times.
- Replace safety signs that are missing or have become illegible.
- Replacement parts that displayed a safety sign should also display current sign.
- Safety signs are available from your distributor, dealer parts department, or factory.

## MZ315C Tip-Up Kit Parts Breakdown

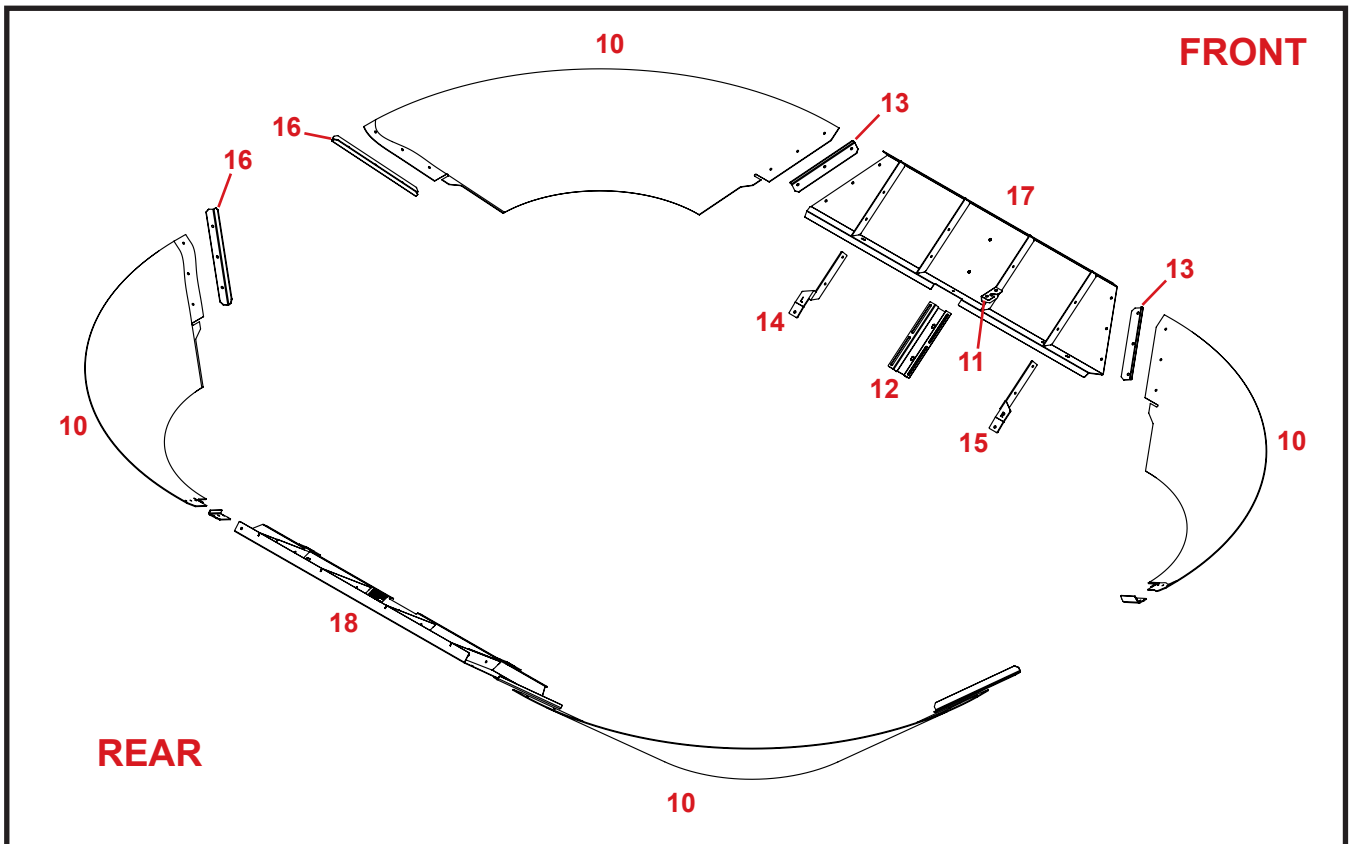

Figure 1

### PARTS LIST

Please order replacement parts by **PART NO.** and **DESCRIPTION.**

REF. NO.	PART NO.	QTY.	DESCRIPTION
1.	1AFC08D0000	5	1/4" Flange Nut
2.	1AFC37DAA05	5	1/4" x 1" Flange Bolt
3.	1AF046EAAH0	12	5/16" x 1.5" Fender Washer
4.	1AF009E0000	24	5/16" Flat Washer
5.	1AFC08E0000	42	5/16" Flange Nut
6.	1AFC37E00L0	18	5/16" x 3/4" Flange Bolt
7.	1AFC37EAA05	24	5/16" x 1" Flange Bolt
8.	1AFC18F0000	4	3/8"-16 Hex Nut Nylock
9.	1AFC12FCA05	4	3/8"-16 x 3" Hex Bolt
10.	1AR00000097	4	MZ315C Rubber Corner
11.	R3E000003Q1	1	Base Light Bracket
12.	R3E000320Q1	1	MZ315/350P Sensor Mount
13.	R3E000315Q1	4	MZ315/350P Corner Angle
14.	R3E000316Q1	2	MZ315/350P Panel Bracket, Left
15.	R3E000317Q1	2	MZ315/350P Panel Bracket, Right
16.	R3E000323Q1	4	MZ315C Corner Angle
17.	R5E000197Q1	1	MZ315P Front Panel Assembly
18.	R5E000203Q1	1	MZ315P Rear Panel Assembly
19.	R3E000324Q1	4	MZ350C Corner Angle

# PANEL ASSEMBLY INSTRUCTIONS

**NOTE:** All steel Tip-Up panels must be installed first to ensure proper fit.

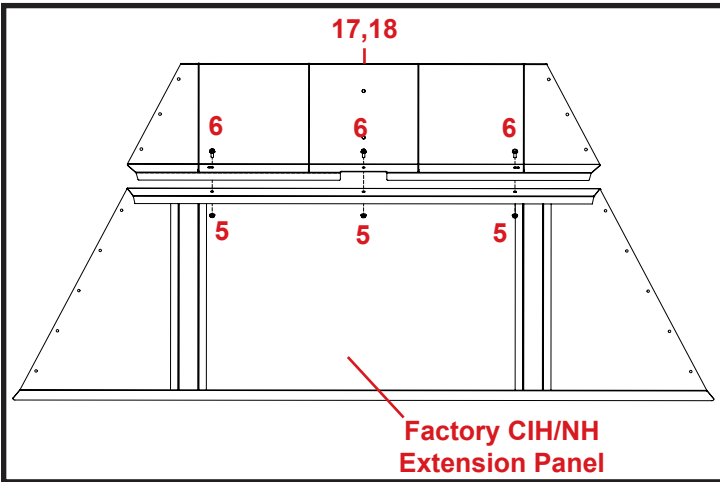

Figure 2

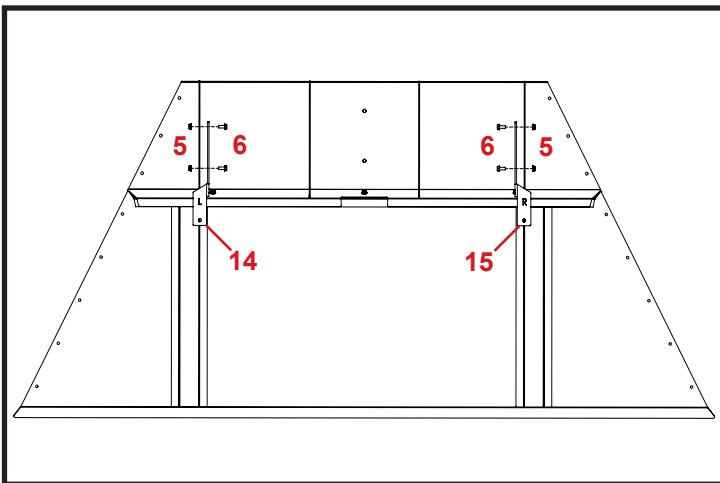

Figure 3

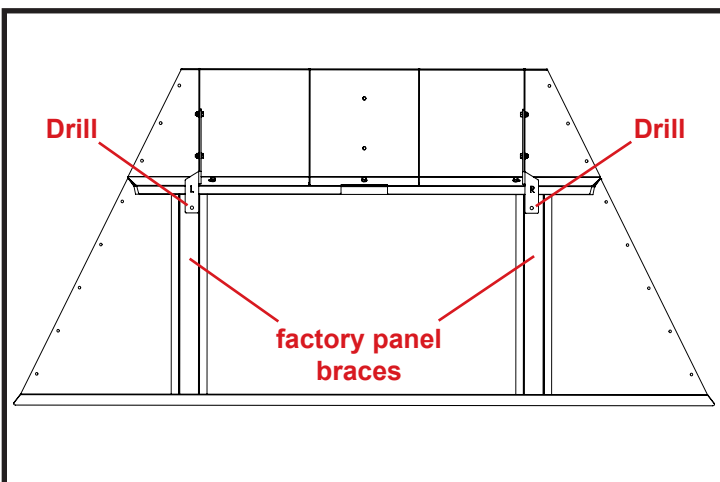

Figure 4



**ATTENTION:** During assembly ensure the following safety decals are located correctly. See illustration on page 5.

Located on inside of rear panel.



## STEP 1:

Fasten the bottom of the Front Panel Assembly to the top of the front factory extension panel using the 5/16" x 3/4" Flange Bolts and 5/16" Flange Nuts included. See Figure 2.

## STEP 2:

Secure the Left & Right Panel Brackets to the stiffeners on the Panel Assembly located just inside of the factory panel braces using the 5/16" x 3/4" Flange Bolts and 5/16" Flange Nuts provided. See Figure 3.

## STEP 3:

Using a power drill and a 3/8" steel bit, drill a hole through the factory panel braces and continue all the way through the panel. Fasten the Left and Right Panel Brackets to the factory braces and panel using 3/8" x 3" Hex Bolts, washers, and 3/8" Nylock Nuts included. Install the bolts from the inside as shown to prevent damage to rubber corners. DO NOT overtighten. See Figures 4 & 5.

## STEP 4:

Repeat steps 1-3 for the Rear panel.

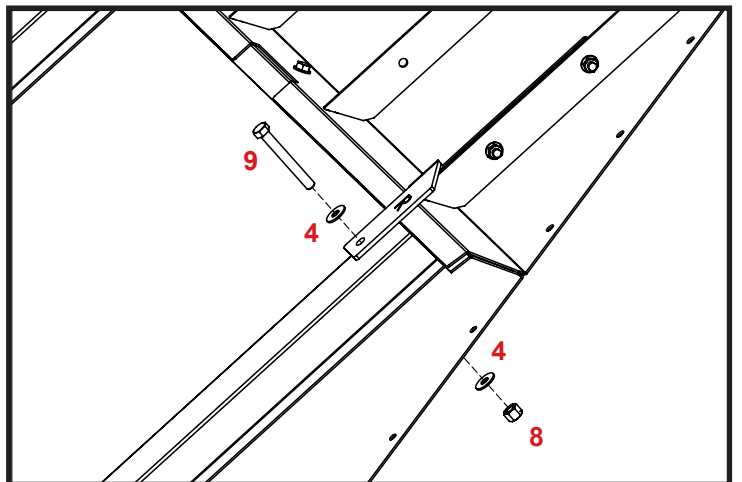

Figure 5

# CORNER ASSEMBLY INSTRUCTIONS

## STEP 5:

Starting on the left side of the Front Panel Assembly, match up the holes on the angled end of the Rubber Corner to the holes on the Front Panel Assembly. Secure the Rubber Corner in place using a Corner Angle, three 5/16" x 1" Flange Bolts, six washers, and three 5/16" Flange Nuts provided. See *Figure 6*.

**NOTE: Identify which bracket will work best on your install and refer to STEP 6a or STEP 6b before continuing.**

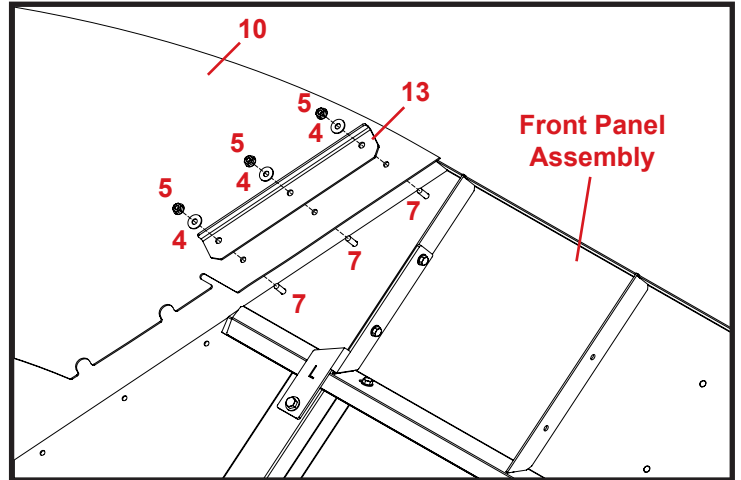

Figure 6

## STEP 6a:

Next, fasten the other end of the Rubber Corner to the Left Cover Assembly. First remove the factory angle and reverse it so that the flange is toward the inside. Place the bottom of the Demco Corner Angle up against the top of the factory angle and line up the side flush with the panel. Mark the holes of the Demco angle onto the panel and drill out holes using a 3/8" bit. Bolt the Rubber Corner and Corner Angle to the factory panel by using two 5/16" x 1" Flange Bolts and two 5/16" Flange Nuts through the drilled holes. Fasten the top hole using a 5/16 x 1" Flange Bolt, 5/16 x 1.5" Fender Washer, and a 5/16" Flange Nut. See *Figure 7a*.

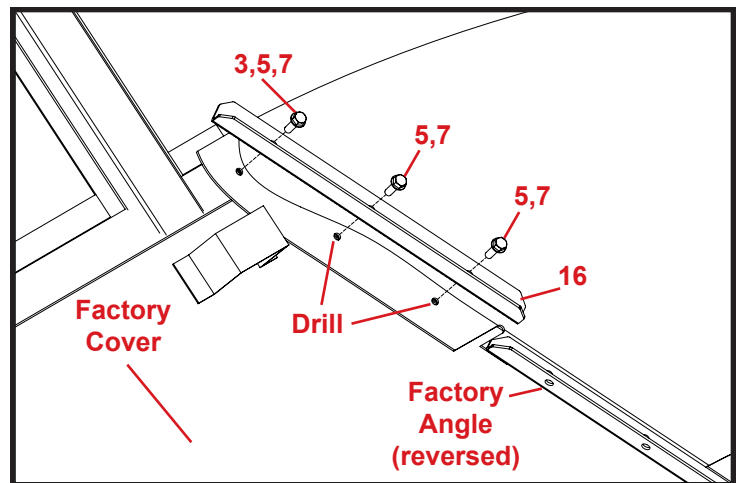

Figure 7a

## STEP 6b:

Next, fasten the other end of the Rubber Corner to the Left Cover Assembly. First remove the factory angle and reverse it so that the flange is toward the inside. Work the Rubber Corner along the factory corner towards the cover to remove any wrinkles. Mark the holes of the Rubber Corner on the cover and drill out holes using a 3/8" bit. Bolt the Rubber Corner and Corner Angle to the factory cover by using two 5/16" x 1" Flange Bolts and two 5/16" Flange Nuts through the drilled holes. Fasten the bottom hole to the panel using a 5/16 x 1" Flange Bolt, 5/16 x 1.5" Fender Washer, and a 5/16" Flange Nut. See *Figure 7b*.

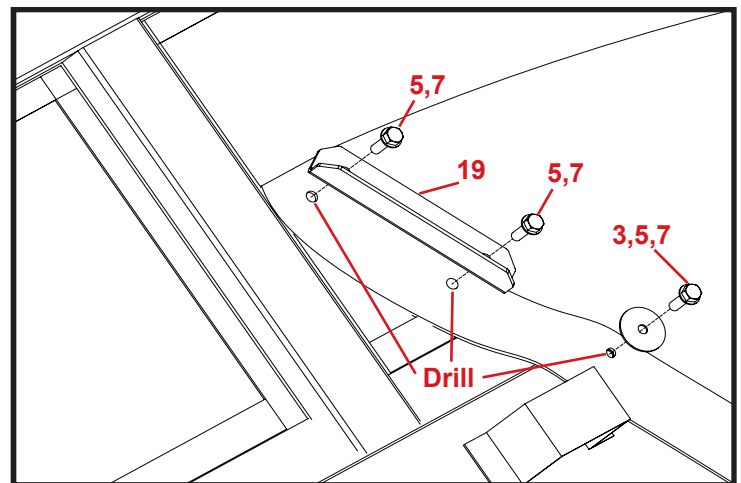

Figure 7b



### **STEP 7:**

Locate the bottom center hole on the Demco Rubber Corner. Drill a hole in the factory rubber corner using that hole as a reference and fasten the Demco Rubber Corner to the factory rubber corner using one 1/4" x 1" Flange Bolt, two 5/16" Fender Washer, and one 1/4" Flange Nut. See *Figure 8*

### **STEP 8:**

Repeat Steps 5-7 for the front right, right rear, and left rear corners.

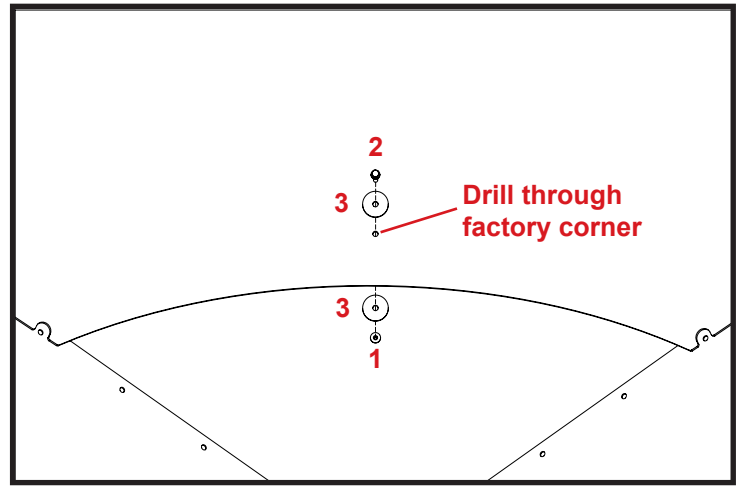

Figure 8

## **BRACKET MOUNTING INSTRUCTIONS**

### **BIN SENSOR:**

Attach the tank full bin Sensor Mount to the Front Panel Assembly with two 5/16" x 3/4" Flange Bolts, two washers, and two 5/16" Flange Nuts. Mount the bin sensor at the lowest point with the original fasteners. See *Figure 9*.

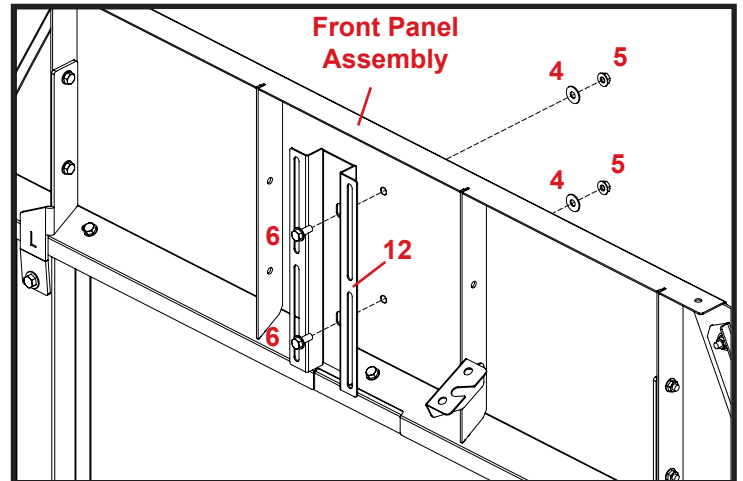

Figure 9

### **LIGHT BRACKET:**

Attach the Light Bracket to the stiffener on the Front Panel Assembly with using a 1/4" x 1" Flange Bolt and a 1/4" Flange Nut. Mount the tank light to the Light Bracket with the original fastener. See *Figure 10*.

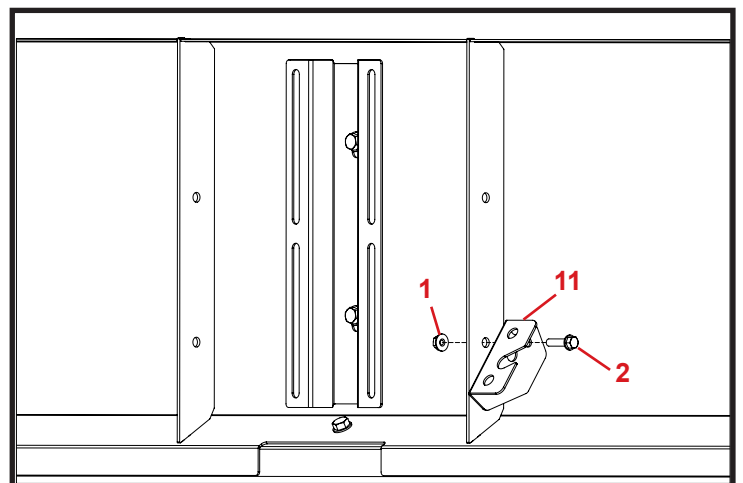

Figure 10

## GPS BRACKETS

REF. NO.	PART NO.	QTY.	DESCRIPTION
20.	R5E000205Q1	1	MZ315/350P GPS Cab Mount, 3-point
21.	R5E000206Q1	1	MZ315/350P GPS Cab Mount, 4-point

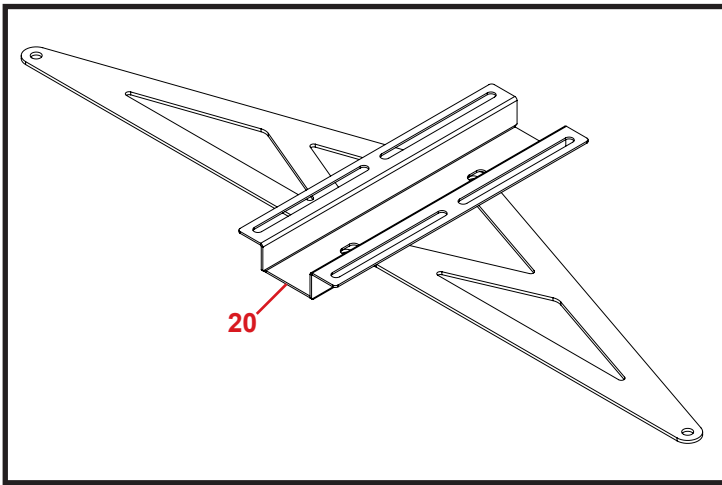

Figure 11

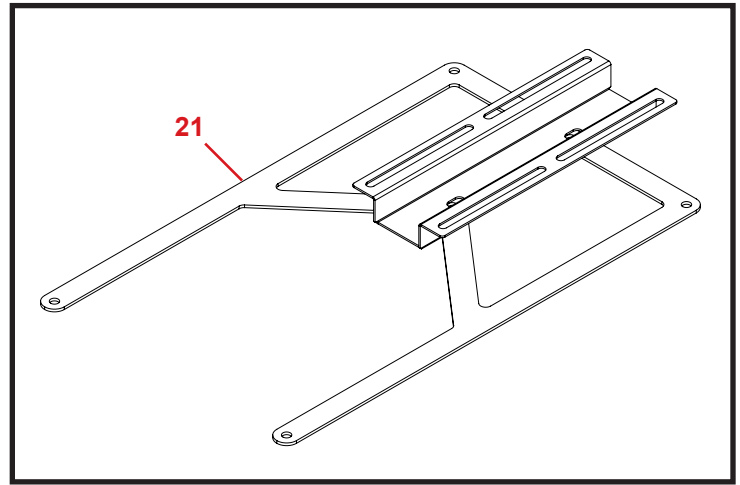

Figure 12

### STEP 1:

Determine which cab style you have by locating the center of the top of your cab. Place the brackets on top of the cab bolts to see which Cab Mount will line up with the bolts at the front most part of the cab.

### STEP 2:

If your cab will accept the 3-point Cab Mount, remove the three cab bolts that line up with that mount. If your cab accepts the 4-point Cab Mount, remove the four cab bolts that line up with that mount.

### STEP 3:

After you have removed the cab bolts, align the Cab Mount with the bolt holes, place the rubber washers between the cab and the Cab Mount, and fasten the Cab Mount to the cab using the cab bolts that were removed in Step 2.

### STEP 4:

Remove factory GPS brackets and mount from the front extension panel. Remove the front and rear brackets from the assembly and switch them around on the mount. (Rear bracket to the front, front bracket to the rear). Attach the reconfigured GPS assembly onto the Cab Mount using the original fasteners. Use the model below as a reference.

**NOTE: The mask angle on the GPS receiver may need to be adjusted to function effectively in its new location.**

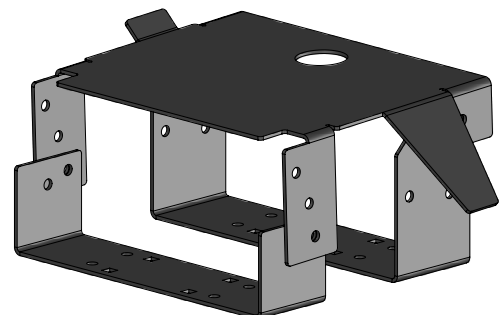

# HANDRAIL INSTALLATION

## WARNING



FAILURE TO REPLACE  
HANDRAIL COULD RESULT  
IN SERIOUS INJURY OR  
DEATH

CIH: 7120

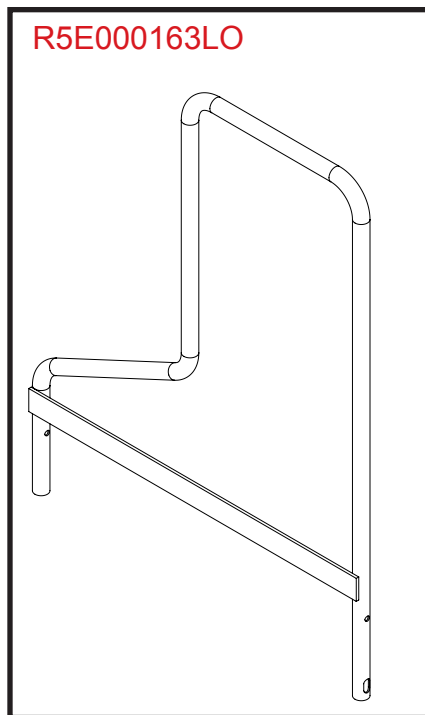

Figure 13

CIH: 7240

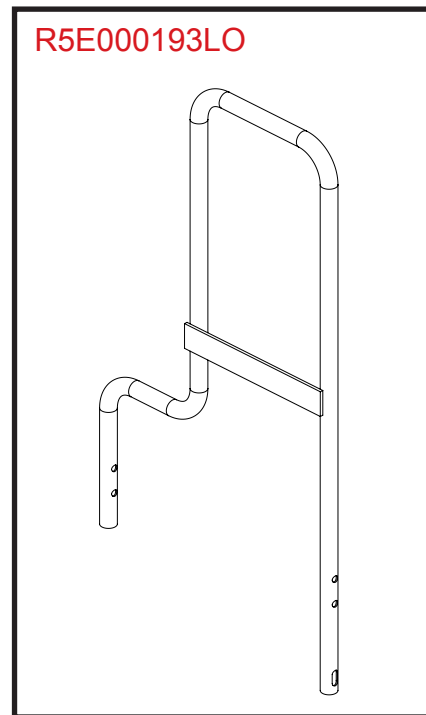

Figure 14

### Step 1:

Using one 16mm and one 17mm wrench remove two nuts and bolts from the factory handrail located on the driver side of the combine's engine compartment.

**Note:** DO NOT discard nuts and bolts! They will be used to mount the Demco handrail.

### Step 2:

Remove the factory handrail and replace with the Demco handrail using the two nuts and two bolts that were removed in Step 1.

# **DEMCO**

4010 320th St., Boyden, IA. 51234

Phone: (712) 725-2311

Fax: (712) 725-2380

Toll Free: 1-800-54DEMCO (1-800-543-3626)

**Demco warranty policies, operator manuals, and product registration  
can be found online:**

**[www.demco-products.com](http://www.demco-products.com)**

