

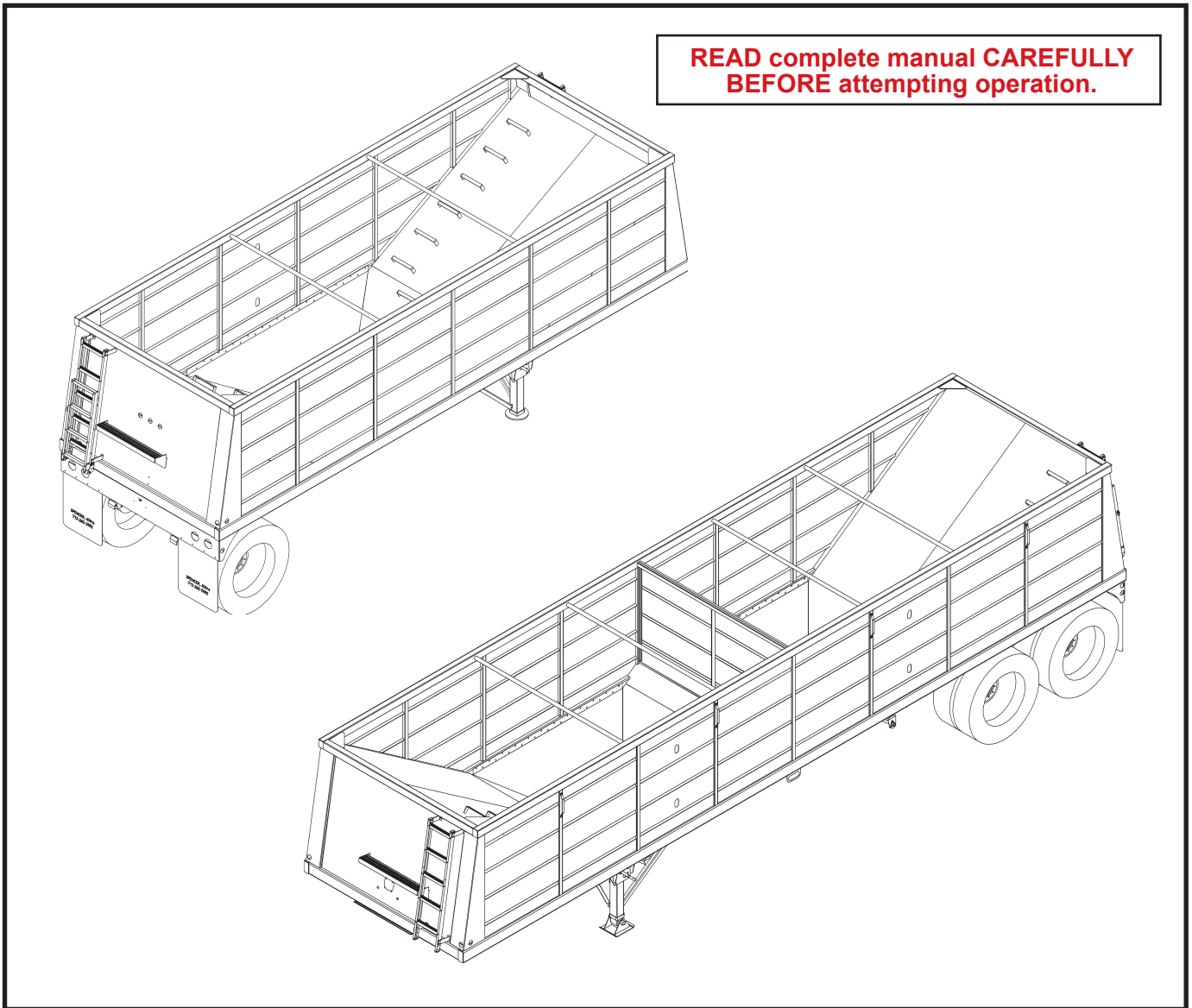

Doing Our Best to Provide You the Best

8G000003, Rev AG
1/10/2022

GRAIN TRAILER Steel Hopper Bottom



OPERATOR MANUAL

CONGRATULATIONS and THANK YOU for purchasing a Demco Grain Trailer.

Table of Contents

Introduction	2
General Information	2
Product Disclaimer	3
Trailer Information	4
Safety, Signal Words	5
Equipment Safety Guidelines	5
Safety Sign Locations	6
Safety Sign Care	6
Safety Sign Application	6
Load Distribution Safety	7
Tire and Lug Nut Safety	7
Bolt Torque Standards	8
Torque Requirements	9
Trailer Towing Guide	10
Trailer Towing Safety Guidelines	10
Operation Safety	11-12
Service and Maintenance Safety	12
Coupling the Trailer to Tow Vehicle	12-14
Uncoupling the Trailer from the Tow Vehicle	15
Mounting the Side Discharge Chute	16
Bolt-On 2-Speed Hopper Assembly Break Down	17
Spring Brake Control Valve - Troubleshooting	18-20
Braking with ABS	21
Easy-Stop ABS Guide	22-24
Landing Gear	25-29
Spring Suspension Information	30-41
Air Ride Suspension Information	42-57
Disc Brake Axles	58-80
Drum Brake Axles	81-111
Lubrication Guide	112-113
Wiring	114
Cleaning the Trailer	114
Visual Inspection	114
Limited General Warranty	115-116
Warranty Registration (cutout)	117
Notes	119

INTRODUCTION

At Demco we strive to design, produce and deliver the highest quality trailer on the market. Our employees have a strong background of knowledge and combined experience in manufacturing to put quality workmanship into our products.

In this manual you will find information covering all models of the Demco Grain Trailer line. Use the table of contents to locate specific areas of interest.

GENERAL INFORMATION

Demco requires that you and anyone else who will be operating and maintaining the trailer read and understand the guidelines in the manual for safe, efficient, and trouble free operations. Proper maintenance, adjustments and use will result in many years of service. Keep this manual handy for frequent reference and to pass on to new operators or owners. If assistance, information, or additional copies of the manual are needed, contact the nearest dealer, a distributor, or Demco.

PLEASE NOTE:

All documents within the manual referring to products not manufactured by Demco have been printed with the permission of the manufacturer specified.

PLEASE NOTE

All references to driver, passenger, front and rear of the trailer are determined from a position behind the trailer and facing forward.

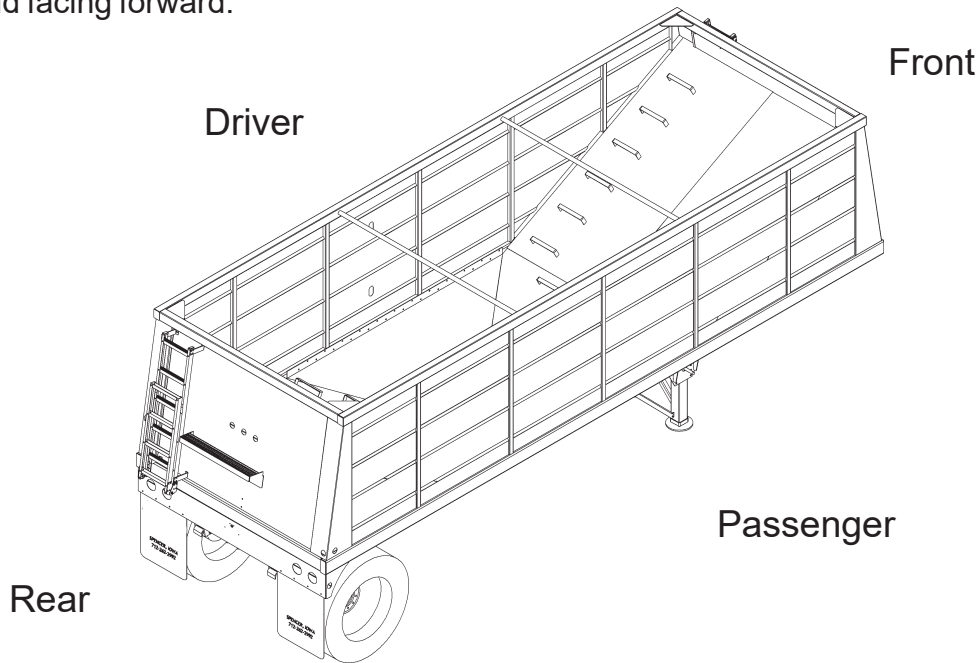

PRODUCT DISCLAIMER

In this document you will find information based on available knowledge at the time of its publication. To be accurate with the information, every effort was made but may not cover all details or variations of a trailer or provide every possibility in connection with its production, operation and maintenance. A Feature and Option may be presented in the manual that is not relevant to this trailer. Demco assumes no obligation of notice, to holders of this document, with changes made to a product.

SPECIFICATIONS AND DESIGN ARE SUBJECT TO CHANGE WITHOUT NOTICE.

Demco is often making improvements and developing new designs. In doing so, we reserve the right to make changes and/or improvements without obligation for equipment sold beforehand. Self-modification to our trailers may affect the operation, function, and safety, so this is not advised. If a replacement part is necessary, Demco should supply it, please contact your nearest dealer or Demco.

DEMCO STATEMENT OF PRODUCT SAFETY

As a producer of agricultural and transportation equipment, Demco is fully aware of its responsibility of providing its customers products that perform their expected use, in a truly safe manner. Safety considerations shall be a fundamental and high precedence part of all engineering/design analysis and judgments involving Demco products. It is our stated policy that our products will be manufactured to coincide with the safety standards specified by the National Association of Trailer Manufacturers and/or any other officially recognized standards at the time manufactured. However, this statement should not be translated to mean that our product will uphold against a customer's own carelessness or disregard for common safety practices specified in each product's manual, nor will we be accountable for any such occurrence.

TRAILER INFORMATION

GAWR (Gross Axle Weight Rating): The maximum gross weight that an axle can support. It is the lowest of axle, wheel, or tire rating. Usually the tire or wheel rating is lower than the axle rating and determines the GAWR. The GAWR is listed on the VIN plate.

GVWR (Gross Vehicle Weight Rating): The maximum allowable gross weight of the trailer and its contents. The gross weight of the trailer includes the weight of the trailer and all of the items with it. GVWR is sometimes referred to as GTWR (Gross Trailer Weight Rating) or MGTW (Maximum Gross Trailer Weight). GVWR, GTWR and MGTW are all the same rating.

The sum total of the GAWR for all trailer axles may be less than the GVWR for the trailer, because some of the trailer load is to be carried by the tow vehicle, rather than by the trailer axle(s). The total weight of the cargo and trailer must not exceed the GVWR, and the load on an axle must not exceed its GAWR. The GVWR is listed on the VIN Plate.

VIN (Vehicle Identification Number): Identifies the trailer in four sections. The first section of three characters identifies the manufacturer. The second section consists of five characters (VIN positions 4-8), these are the attributes of the vehicle. The third section is one character which is the check digit. The fourth section consists of eight characters (VIN positions 10-17). The first character represents the vehicle model year, the second character represents the plant of manufacture. The third through eighth characters are a sequential production number. The VIN Plate is located on the main frame at the front, passenger side of the trailer.

PSI (Pounds Per Square Inch): The tire pressure measurement. The PSI is listed on the VIN Plate.

Empty Weight: Some information that comes with the trailer is not a reliable source for 'empty' weight. The shipping documents list average or standard weights and your trailer may be equipped with options. To determine the 'empty' or weight of your trailer, have trailer weighed at a commercial scale.

Kingpin: The coupler on the front of the trailer that connects to the fifth wheel plate of the tow vehicle.

Fifth Wheel Plate: A device on the tow vehicle that pulls and supports the weight of the trailer.

Trailer Lighting and Braking Connectors: A device that connects electrical power from the tow vehicle to the trailer. If your trailer has electric brakes, the connector will also supply power to the brakes from the tow vehicle.

Landing Gear: A device on the trailer that is often referred to as the 'jack', used to raise and lower the trailer and for storage of the trailer. To operate the landing gear, pull the crank shaft outward for high gear and push in for low gear speed. This is also the same handle, which will be used to open the hopper doors. Demco uses the Holland - Model Atlas 55 as standard equipment on the 34' thru 42' trailers. The Holland - Model Atlas 55 with Dropleg is used on the 24', 28' and 30' trailers for improved swing auger clearance.

Registration Holder: This is located on the center of the kingpin. Use this to keep the registration with the trailer at all times. The registration holder is often referred to as the "manifest" holder.

SAFETY

TAKE NOTE! THIS SAFETY ALERT SYMBOL FOUND THROUGHOUT THIS MANUAL IS USED TO CALL YOUR ATTENTION TO INSTRUCTIONS INVOLVING YOUR PERSONAL SAFETY AND SAFETY OF OTHERS. FAILURE TO FOLLOW THESE INSTRUCTIONS CAN RESULT IN INJURY OR DEATH!



**THIS SYMBOL MEANS:
ATTENTION!
BECOME ALERT!
YOUR SAFETY IS INVOLVED!**

SIGNAL WORDS

Note use of following signal words **DANGER**, **WARNING**, and **CAUTION** with safety messages. The appropriate signal word for each has been selected using the following guidelines:

DANGER: Indicates an imminently hazardous situation that, if not avoided, will result in death or serious injury. This signal word is to be limited to most extreme situations typically for machine components which, for functional purposes, cannot be guarded.

WARNING: Indicates a potentially hazardous situation that, if not avoided, could result in death or serious injury, and includes hazards that are exposed when guards are removed. It may also be used to alert against unsafe practices.

CAUTION: Indicates a potentially hazardous situation that, if not avoided, may result in minor or moderate injury. It may also be used to alert against unsafe practices.



EQUIPMENT SAFETY GUIDELINES

Every year many accidents occur which could have been avoided by a few seconds of thought and a more careful approach to handling equipment. You, the operator, can avoid many accidents by observing the following precautions in this section. To avoid personal injury, study the following precautions and insist those working with you, or you yourself, follow them.

Operator should be a responsible adult. **DO NOT ALLOW PERSONS TO OPERATE THIS UNIT UNTIL THEY HAVE DEVELOPED A THOROUGH UNDERSTANDING OF SAFETY PRECAUTIONS AND HOW IT WORKS.**

DO NOT modify the trailer in anyway. Doing so may impair the function and/or safety and could affect the life of the trailer.

Never exceed the maximum capacity of the trailer. By doing so you risk damage to your Demco trailer. If it's ability to do a job, or to do so safely is in question **DON'T TRY IT.**

Review safety instructions with all users annually.

Replace any caution, warning, danger or instruction safety decal that is not readable or is missing. Location of such decals is indicated in this booklet.

Do not paint over, remove, or deface any safety signs or warning decals on your equipment. Observe all safety signs and practice instructions on them.

SAFETY SIGN LOCATIONS

Types of safety sign and locations on equipment are shown in illustration below. Good safety requires that you familiarize yourself with various safety signs, type of warning, and area or particular function related to that area, that requires your SAFETY AWARENESS.

SAFETY SIGN CARE

- ◆ Keep safety signs clean and legible at all times.
- ◆ Replace safety signs that are missing or have become illegible.
- ◆ Replacement parts that display a safety sign should also display current sign.
- ◆ Safety signs are available from Demco Spencer Plant.

Driver Side-Rear

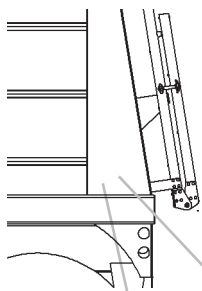

DEMCO
This product has been laser aligned for accuracy.

NOTICE:
If the ABS indicator lamp comes on and stays on when you apply the brakes to a moving vehicle, the trailer ABS is not working properly. The ABS must be serviced as soon as possible upon completion of your trip to ensure full anti-lock braking capability.
TP-95172 **MERITOR WABCO** Rev. 7/01

Front Side-Center

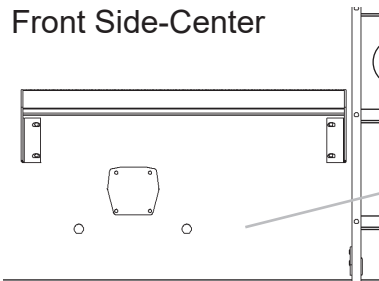

Rear Side-Center

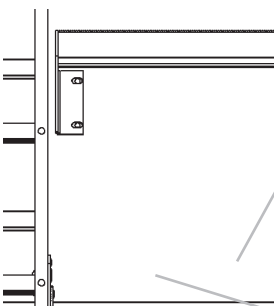

HOW TO APPLY SAFETY DECALS

1. Be sure that the installation area is clean and dry.
2. Be sure temperature is above 50°F(10°C).
3. Decide on exact position before removing the backing paper.
4. Remove smallest portion of split backing paper.
5. Align decal over specified area and carefully press the small portion with the exposed sticky backing in place.
6. Slowly peel back remaining paper and carefully smooth remaining portions of decal into place.
7. Small air pockets can be pierced with a pin and smoothed out using a piece of decal backing paper.

REF. NO.	PART NO.	QTY.	DESCRIPTION
1.	1AQBY065000	1	Front Wall Decal Sheet
2.	1AQBZ065000	1	Rear Wall Decal Sheet
3.	1AQAY000000	1	Product Has Been Laser Aligned



LOAD DISTRIBUTION SAFETY

The total weight of the load you put on the trailer, plus the empty weight of the trailer itself, must not exceed the trailer's Gross Vehicle Weight Rating (GVWR). You must distribute the load on the trailer such that the load on any tire or axle does not exceed the tire load rating or the Gross Axle Weight Rating (GAWR). If you do not know the weight of your trailer you must weigh it at a commercial scale. See your VIN Plate for proper ratings. Not following these guidelines could cause serious injury or even death.



TIRE AND LUG NUT SAFETY

It is essential to inspect the trailer tires and wheels before each tow. Trailer tires are more likely to fail compared to car tires due to the heavier load the trailer carries. Please follow the list of guidelines and/or possibilities below that could cause serious injury or even death.

- ◆ Replace the tire before towing if the tire has a bald spot, cut, bulge, is showing any cords, or is cracked.
- ◆ If uneven tread is noticed, take the trailer to a dealer service center for an inspection. Tire imbalance, axle misalignment, or incorrect inflation could cause the uneven tread.
- ◆ Too little of tread will not be adequate enough for traction and can cause loss of control on wet highways.
- ◆ Tire pressure that is improper causes an unstable trailer and could blowout the tire causing loss of control.
- ◆ Check the tire pressure before towing, while the tire is cold. For the recommended PSI, see the VIN Plate or the side wall of the tire.
- ◆ Always order and install tires and wheels with appropriate type and load capacity to meet or exceed gross weight of unit.

The inspection of the tire and wheel lug nuts is necessary since they are prone to loosen after first being assembled. Please follow the list of guidelines and/or possibilities below that could cause serious injury or even death.

- ◆ When towing a new trailer, check the lug nuts after the first 50 to 100 miles of driving.
- ◆ Metal creep between the wheel and the lug nuts will cause wheel to loosen and could come off. Check to make sure the lug nuts are tight before each tow.
- ◆ Improper torque could cause the wheel to separate from trailer. A torque wrench should be used to tighten the lugs nuts. If one is not available use a lug wrench then take to a trailer dealer or service garage to tighten them to the required torque.

BOLT TORQUE

TORQUE DATA FOR STANDARD NUTS, BOLTS, AND CAPSCREWS.

Tighten all bolts to torques specified in chart unless otherwise noted. Check tightness of bolts periodically, using bolt chart as guide. Replace hardware with same grade bolt.

NOTE: Unless otherwise specified, high-strength Grade 5 hex bolts are used throughout assembly of equipment.

Bolt Torque for Standard bolts *



Torque Specifications

"A"	GRADE 2		GRADE 5		GRADE 8	
	lb-ft	(N.m)	lb-ft	(N.m)	lb-ft	(N.m)
1/4"	6	(8)	9	(12)	12	(16)
5/16"	10	(13)	18	(25)	25	(35)
3/8"	20	(27)	30	(40)	45	(60)
7/16"	30	(40)	50	(70)	80	(110)
1/2"	45	(60)	75	(100)	115	(155)
9/16"	70	(95)	115	(155)	165	(220)
5/8"	95	(130)	150	(200)	225	(300)
3/4"	165	(225)	290	(390)	400	(540)
7/8"	170	(230)	420	(570)	650	(880)
1"	225	(300)	630	(850)	970	(1310)

Bolt Torque for Metric bolts *

"A"	CLASS 8.8		CLASS 9.8		CLASS 10.9	
	lb-ft	(N.m)	lb-ft	(N.m)	lb-ft	(N.m)
6	9	(13)	10	(14)	13	(17)
7	15	(21)	18	(24)	21	(29)
8	23	(31)	25	(34)	31	(42)
10	45	(61)	50	(68)	61	(83)
12	78	(106)	88	(118)	106	(144)
14	125	(169)	140	(189)	170	(230)
16	194	(263)	216	(293)	263	(357)
18	268	(363)	--	--	364	(493)
20	378	(513)	--	--	515	(689)
22	516	(699)	--	--	702	(952)
24	654	(886)	--	--	890	(1206)

Torque figures indicated are valid for non-greased or non-oiled threads and heads unless otherwise specified. Therefore, do not grease or oil bolts or capscrews unless otherwise specified in this manual. When using locking elements, increase torque values by 5%.

* GRADE or CLASS value for bolts and capscrews are identified by their head markings.

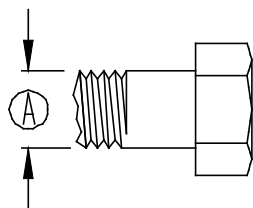

GRADE-2 GRADE-5 GRADE-8

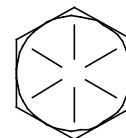
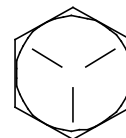
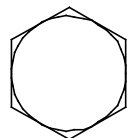

CLASS 8.8 CLASS 9.8 CLASS 10.9



TORQUE REQUIREMENTS

It is extremely important to apply and maintain proper wheel mounting torque on your trailer axle. Torque is a measure of the amount of tightening applied to a fastener (nut or bolt) and is expressed as length times force. For example, a force of 90 pounds applied at the end of a wrench one foot long will yield 90 lbs/ft of torque. Torque wrenches are the best method to assure the proper amount of torque is being applied to a fastener.

Note: Wheel nuts or bolts must be applied and maintained at the proper torque levels to prevent loose wheels, broken studs, and possible dangerous separation of wheel from your axle.

Be sure to use only the fasteners matched to the cone angle of your wheel (usually 60 degrees or 90 degrees). The proper procedure for attaching your wheels is as follows:

1. Start all bolts or nuts by hand to prevent cross threading.
2. Tighten bolts or nuts in the following sequence.
3. The tightening of the fasteners should be done in stages. Following the recommended sequence, tighten fasteners per wheel torque requirements diagram:

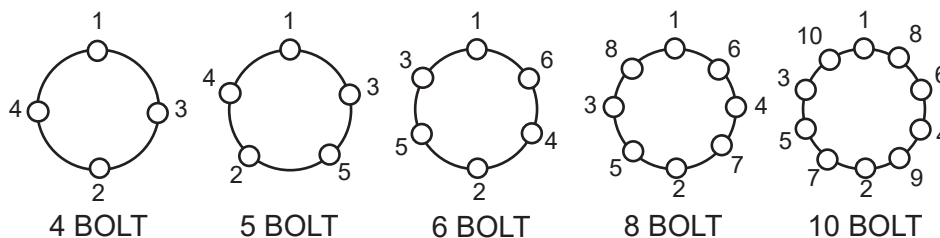

4. Wheel nuts or bolts should be torqued before first road use and after each wheel removal. Check and re-torque after the first 50 miles and again at 100 miles. Check periodically thereafter.

WHEEL AND RIM TORQUE REQUIREMENTS

Description	Application	Minimum Torque	Maximum Torque
		(lbs/ft)	(lbs/ft)
1/2" Cone Nut	12" – 13" Wheel	50	65
	14" – 15" Wheel	90	120
5/8" Cone Nut	Flat Disc Wheel	175	225
3/4" Hex Nut	Demountable Ring Clamp	210	260
3/4" Spherical Nut	Single Wheel	450	500
	Inner Dual	450	500
1-1/2" Spherical Nut	Outer Dual	450	500
5/8" Flange Nut	Wheels	275	325



TRAILER TOWING GUIDE

Driving a vehicle while towing a trailer is completely different from driving the same vehicle without a trailer. Acceleration, manipulation and braking are all reduced. It takes longer to get up to speed; you need more room to turn and pass, and more distance to stop. You will need to spend time adjusting to the different feel and maneuverability of the vehicle with a loaded trailer. Because of the considerable differences in all aspects of manipulation when towing a trailer, the dangers and risks of injury are also much greater than when driving without a trailer. You are responsible for keeping your vehicle and trailer in control, and for all the damage that is caused if you lose control of your vehicle and trailer.

Before you start towing the trailer, you must follow all of the instructions for inspection, testing, loading and coupling. Also, before you start towing, adjust the mirrors so you can see the trailer as well as the area to the rear of it.

Drive slowly at first, 5 m.p.h. or so, and turn the wheel to get the feel of how the vehicle and trailer combination responds. Next, make some right and left hand turns. Watch in your side mirrors to see how the trailer follows the vehicle. Turning with a trailer attached requires more room. Stop a few times from speeds no greater than 10 m.p.h. Try using different combinations of trailer/air brakes and vehicle brakes. Note the effect that the trailer brakes have when they are the only brakes used.



TRAILER TOWING SAFETY GUIDELINES

- ◆ Before towing, check coupling, trailer brakes, tires, wheels and lights.
- ◆ Check the lug nuts and bolts for proper tightness.
- ◆ Check coupler tightness after towing 50 miles.
- ◆ Use your mirrors to verify that you have room to change lanes or pull into traffic.
- ◆ Use your turn signals well in advance.
- ◆ Allow plenty of stopping distance for your trailer and vehicle.
- ◆ Do not drive so fast that the trailer begins to sway due to speed.
- ◆ Allow plenty of room for passing. A rule of thumb is that the passing distance with a trailer is four times the passing distance without a trailer.
- ◆ Shift your automatic transmission into a lower gear for city driving.
- ◆ Use lower gears for climbing and descending grades.
- ◆ Do not ride the brakes while descending grades; they may get so hot that they stop working. Then you will potentially have a runaway vehicle and trailer.
- ◆ To conserve fuel, don't use full throttle to climb a hill. Instead, build speed on the approach.
- ◆ Slow down for bumps in the road. Take your foot off the brake when crossing the bump.
- ◆ Do not brake while in a curve unless absolutely necessary. Instead, slow down before you enter the curve and power through the curve. This way, the towing vehicle remains "in control."
- ◆ Do not apply the brakes to correct extreme trailer swaying. Continued pulling of the trailer, and even slight acceleration, will provide a stabilizing force.



OPERATION SAFETY

- ◆ Carefully study and understand the Owner's Manual and all safety decals before operating, servicing, adjusting or repairing.
- ◆ It is the owner/operators responsibility to read the manual and instruct other operators to read the manual before operating.
- ◆ Before towing, check kingpin, trailer brakes, tires, wheels and lights.
- ◆ Always follow state and local regulations regarding safety chains and auxiliary lighting when towing.
- ◆ Check the lug nuts and bolts for proper tightness.
- ◆ Keep wheels and lug nuts tightened to specific torque.
- ◆ Secure wheels when trailer is not being used.
- ◆ Assure tires are inflated evenly.
- ◆ Make sure the brakes are evenly adjusted.
- ◆ Visually inspect trailer for any loose bolts, worn parts, or cracked welds, and make necessary repairs. (Follow maintenance safety instructions included in this manual.)
- ◆ Securely attach to towing vehicle.
- ◆ Make sure that tow rating on vehicle is high enough for what is being towed.
- ◆ Check coupler tightness after towing 50 miles.
- ◆ Clean reflectors and lights and check to make sure that they are working.
- ◆ Use your mirrors to verify that you have room to change lanes or pull into traffic.
- ◆ Use your turn signals well in advance.
- ◆ Allow plenty of stopping distance for your trailer and vehicle.
- ◆ Do not drive so fast that the trailer begins to sway due to speed.
- ◆ Allow plenty of room for passing. A rule of thumb is that the passing distance with a trailer is four times the passing distance without a trailer.
- ◆ Always drive at a save speed and ensure that you are driving slow enough to make an emergency stop if necessary.
- ◆ No passengers allowed – Do not carry passengers anywhere on the trailer.
- ◆ Beware of bystanders, particularly children, always look around and make sure it is safe to start engine of tow vehicle or move the trailer. This is particularly important with higher noise levels, as you may not hear people shouting.
- ◆ When halting operations, even periodically, set towing vehicles parking brake, shut off engine, and remove the ignition key, to prevent unauthorized operation.
- ◆ Keep hands, feet, hair and clothing away from all moving and/or rotating parts.
- ◆ A safe working environment is provided for the operator and bystanders just by following the recommended procedures throughout this manual.
- ◆ Be extra careful on inclines.
- ◆ Use lower gears for climbing and descending grades.
- ◆ Do not ride the brakes while descending grades; they may get so hot that they stop working. Then you will potentially have a runaway vehicle and trailer.
- ◆ To conserve fuel, don't use full throttle to climb a hill. Instead, build speed on the approach.
- ◆ Do not brake while in a curve unless absolutely necessary. Instead, slow down before you enter the curve and power through the curve. This way, the towing vehicle remains "in charge."
- ◆ Do not apply the brakes to correct extreme trailer swaying. Continued pulling of the trailer, and even slight acceleration, will provide a stabilizing force.
- ◆ Slow down for bumps in the road. Take your foot off the brake when crossing the bump.
- ◆ Shift your automatic transmission into a lower gear for city driving.



OPERATION SAFETY (continued)

- ◆ In addition to the design and configuration of a trailer, hazard control and accident prevention are dependent upon the knowledge, concern, and common sense of personnel involved in the operation, transportation, maintenance and storage of the trailer.
- ◆ Practice the operations and functions of your trailer. Don't hurry the learning process or take it for granted.
- ◆ Untrained operators are not qualified to operate the trailer.
- ◆ If the operation safety is followed, along with a good maintenance program your trailer will provide you with years of trouble-free service.
- ◆ With ideal road conditions follow the posted speed limit but do not exceed 60 mph.



SERVICE AND MAINTENANCE SAFETY

Carefully read this section on trailer service and maintenance safety. Good maintenance is your responsibility. Performing maintenance according to the schedule will prolong the performance and life of you trailer and ensure the safety and liability of the operation. If you cannot perform the required maintenance talk to your dealer about having them done. Also check the relevant component manufacturer's manual if available.

- ◆ Make sure there is plenty of ventilation. Never operate engine of towing vehicle in a closed building. Exhaust fumes may cause asphyxiation.
- ◆ Always block wheels and never use a jack as sole support.
- ◆ Always use proper tools or equipment for job at hand.
- ◆ Use extreme caution when making adjustments.
- ◆ Follow torque chart in this manual when tightening bolts and nuts.
- ◆ Openings in skin and minor cuts are susceptible to infection from brake fluid.
- ◆ After servicing, be sure all tools, parts and equipment are removed
- ◆ Do not allow grease or oil to build up on any step or platform.
- ◆ When replacing bolts, refer to owner's manual for proper size and grade.
- ◆ Refer to bolt torque chart for head identification marking.
- ◆ When replacement parts are necessary for periodic service and maintenance, genuine factory replacement parts must be used to restore your trailer. **Manufacturer will not claim responsibility for use of unapproved parts and/or accessories or other damages.**
- ◆ If the trailer has been altered in any way from original design, any liability for injury or warranty will not be accepted by Demco.
- ◆ A fire extinguisher and first aid kit should be kept accessible while performing any service and maintenance on the trailer.



COUPLING THE TRAILER TO TOW VEHICLE

- ◆ Inspect Fifth Wheel
 1. Check for damage/missing parts.
 2. Check to see that mounting to tractor is secure, no cracks in frame.
 3. Be sure that the fifth wheel plate is greased as required. Failure to keep the fifth wheel plate lubricated could case steering problems due to friction between the tractor and trailer.



COUPLING THE TRAILER TO TOW VEHICLE (continued)

4. Check if fifth wheel is in proper position for coupling. Wheel tilted down towards rear of tractor, jaws open, safety unlocking handle in automatic lock position.
 5. If you have a sliding fifth wheel, make sure it is locked.
 6. Make sure the trailer kingpin is not bent or broken.
- ◆ Inspect Area
 1. Make sure area around vehicle is clear.
 2. Be sure trailer spring brakes are on.
 3. Check that cargo is secured against movement due to tractor being coupled to the trailer.
 - ◆ Position Tractor
 1. Put the tractor directly in front of the trailer. Never back under the trailer at an angle, you could push the trailer sideways and damage the landing gear.
 2. Check position using outside mirrors and looking down both sides of the trailer.
 - ◆ Back Slowly
 1. Back up until the fifth wheel is just touching the trailer. Don't hit the trailer.
 - ◆ Secure Tractor
 1. Put parking brake on and transmission in neutral.
 - ◆ Check Trailer Height
 1. The trailer should be low enough that it is raised slightly by the tractor when the tractor is backed under. Raise and lower the trailer as needed. If trailer is too low, the tractor may strike and damage the front of trailer. If the trailer is too high, it may not couple correctly.
 2. Check that the kingpin and fifth wheel are aligned.
 - ◆ Connect Air Lines to Trailer
 1. Make sure airlines are safely supported where they won't be crushed or caught while tractor is backing under the trailer.
 2. Connect tractor emergency red airline to trailer emergency red glad hand. This provides continuous air supply to trailer.
 3. Connect service blue airline to trailer service blue glad hand. This provides air to trailer only when brake is applied.
 - ◆ Supply Air to Trailer
 1. From cab, push in "air supply" knob or move tractor protection valve control from the "emergency" to the "normal" position to supply air to the trailer brake system.
 2. Wait until the air pressure is normal.
 3. Check brake system for crossed airlines.
 4. Shut engine off so you can hear brakes.
 5. Apply and release trailer brakes, listen for sound of brakes being applied and released. You should hear the brakes move when applied and air escape when the brakes are released.
 6. Check air brake system pressure gauge for signs of major air loss.



COUPLING THE TRAILER TO TOW VEHICLE (continued)

7. When you are sure trailer brakes are working, start engine.
 8. Check again that the air pressure is up to normal.
- ◆ Lock Trailer Brakes
 1. Pull out the “air supply” knob, or move the tractor protection valve control from “normal” to “emergency”.
 - ◆ Back Under Trailer
 1. Use lowest reverse gear.
 2. Back trailer slowly to avoid hitting the kingpin too hard.
 3. Stop when the kingpin is locked into the fifth wheel.
 - ◆ Check Connection for Security
 1. Raise trailer landing gear slightly off the ground.
 2. Pull tractor gently forward while the trailer brakes are still applied.
 3. Check and make sure that the trailer is locked onto the tractor.
 - ◆ Secure Vehicle
 1. Put parking brake on and transmission in neutral.
 2. Shut off engine and take key with you so someone else won't move the truck while you are under it.
 - ◆ Inspect Coupling
 1. Use flashlight if necessary.
 2. Make sure there is no spacing between trailer and fifth wheel. If there is a space something is wrong. **Kingpin may be on top of closed fifth wheel jaws; trailer will come loose very easily.**
 3. Go under the trailer and look into the back of the fifth wheel. Make sure jaws are closed around the shank of the kingpin.
 4. Check that the locking lever is in the “lock” position.
 5. Check that the safety catch is in a position over locking lever. On some fifth wheels the catch must be put in place by hand.
 6. If the coupling isn't right, fix before operating.
 - ◆ Connect the Electrical Cord and Check Air Lines
 1. Plug the electrical cord into the trailer and fasten the safety catch.
 2. Check both airlines and electrical lines for signs of damage.
 3. Make sure air and electrical lines will not hit any moving parts on vehicle.
 - ◆ Raise Trailer Landing Gear
 1. Use low gear to begin raising the landing gear, once free of weight, switch to high gear.
 2. Raise the landing gear all the way up. Never drive with the landing gear only part way up, one or both could catch on objects.
 3. After raising landing gear, secure the crank handle safely.
 4. When full weight of trailer is resting on tractor:
 5. Check for enough clearance between rear of tractor frame and landing gear. When the tractor/trailer makes a sharp turn, the landing gear must clear the back of the tractor.
 6. Check that there is enough clearance between the top of the tractor tires and the nose of the trailer.



UNCOUPLING THE TRAILER FROM TOW VEHICLE

- ◆ Position the Tractor and Trailer
 1. Make sure surface can support weight of trailer.
 2. Have the tractor aligned with the trailer, pulling out at an angle can cause damage to the landing gear.
- ◆ Ease Pressure on Locking Jaw
 1. Shut off trailer air supply to lock trailer brakes.
 2. Ease pressure on fifth wheel locking plate by backing up gently, this will help you release the fifth wheel locking lever.
 3. Put parking brake on while tractor is pushing against the kingpin. This will hold the tractor with pressure off the locking jaw.
- ◆ Inspect Area
 1. Make sure area around the vehicle is clear.
- ◆ Lower the Landing Gear
 1. Lower the landing gear until it makes firm contact with the ground, turn crank in low gear a few extra turns; this will lift some weight off the tractor. Do not lift trailer off the fifth wheel. This will make it easier to unlatch the fifth wheel and easier to couple next time.
- ◆ Disconnect Airlines and Electrical Cables
 1. Disconnect airlines from trailer. Connect glad hands to dummy coupler at back of cab, or coupler them together.
 2. Hang electrical cable plug down to prevent moisture from entering the end.
 3. Make sure lines are supported so they won't be damaged while driving the tractor.
- ◆ Unlock Fifth Wheel
 1. Pull the release handle to "open" position.
 2. Keep legs and feet clear of the rear tractor wheel to avoid serious injury in case the vehicle moves.
- ◆ Drive Tractor Partially Clear of Trailer
 1. Drive tractor forward until fifth wheel comes out from under the trailer.
 2. Stop the tractor frame under trailer; this prevents the trailer from falling to ground if landing gear should sink or fail.
- ◆ Secure Tractor
 1. Apply parking brake and place transmission in neutral.
- ◆ Inspect Trailer Landing Gear
 1. Make sure ground is supporting the trailer and landing gear is not damaged.
- ◆ Pull Tractor Clear of Trailer
 1. Release parking brake.
 2. Check the area and drive tractor clear of trailer.

MOUNTING THE SIDE DISCHARGE CHUTE

Position the hopper assembly with the bottom **inside** the door rail flange. Mark the top four hole positions for drilling, then open the side chute door and mark the bottom two hole positions and the rectangular opening for the grain unloading. Remove the assembly and drill 3/8" holes and cut out the rectangular opening. Bolt assembly to hopper and add rubber straps by bolting to the vertical braces.

Side Discharge Chute

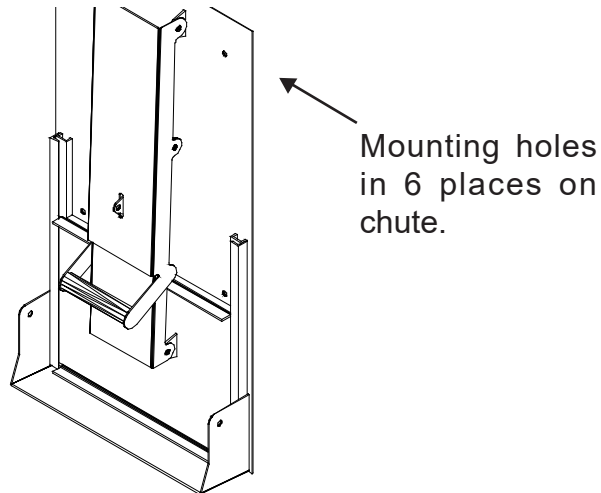

Hopper: Top (attached to trailer)

Arrows (2) show where to
mount rubber straps.

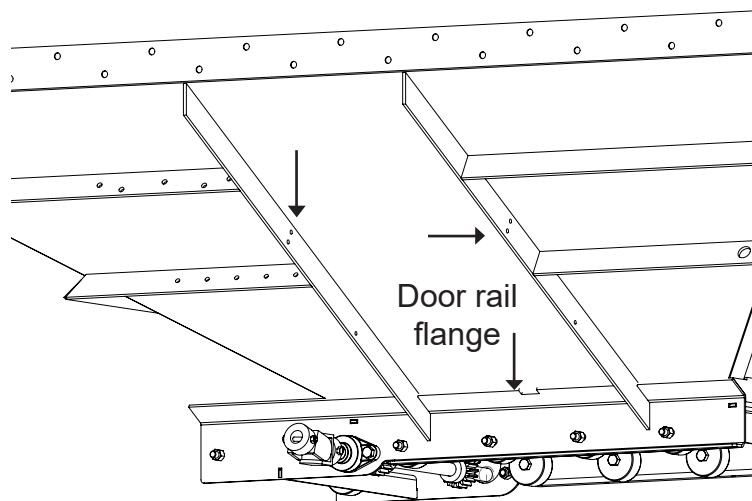

Hopper: Bottom

BOLT-ON 2-SPEED HOPPER ASSEMBLY BREAK DOWN

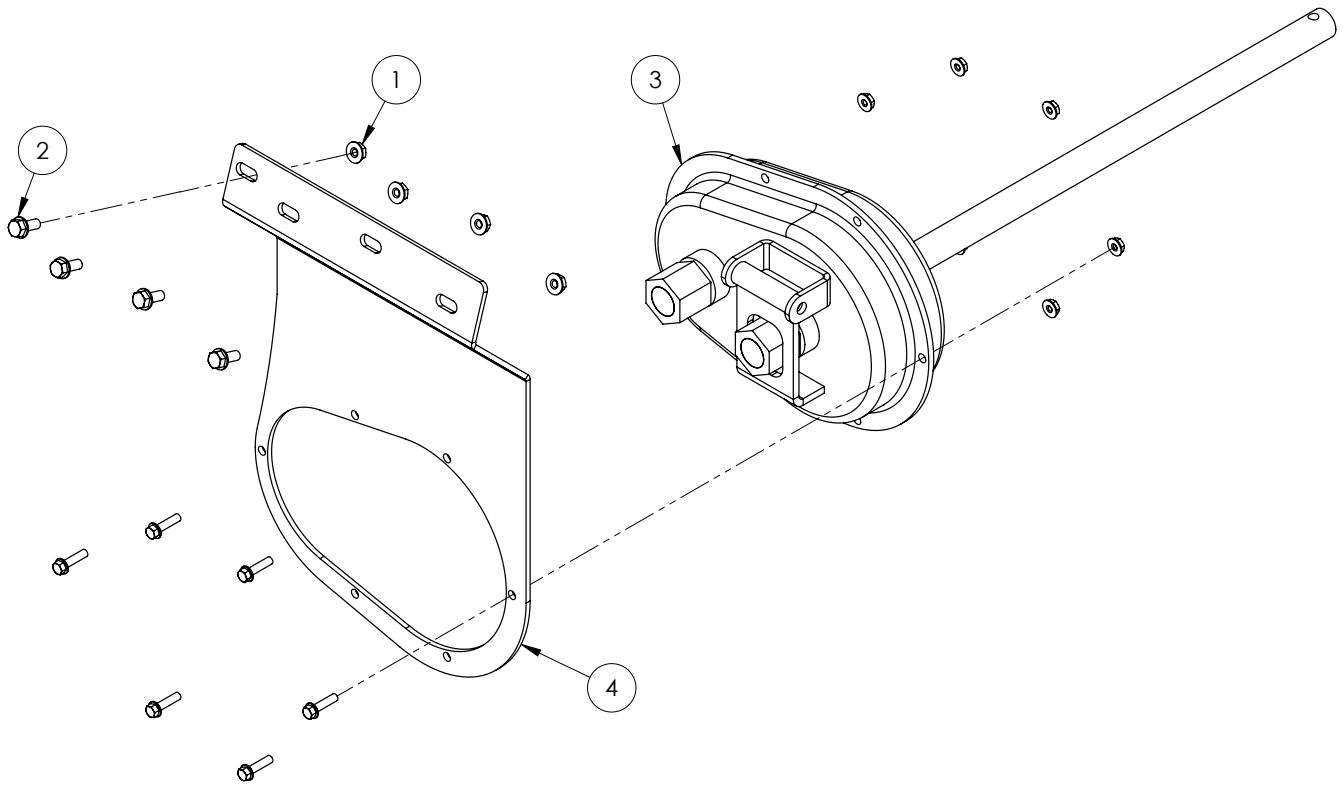

REF. NO.	PART NO.	QTY.	DESCRIPTION
1.	1AFC08E0000	4	5/16"-18 FLANGE NUT
2.	1AFC37E00L0	4	5/16"-18 x 3/4" FLANGE BOLT
3.	3G000270	1	GT742089 GEARBOX, DRILL OPERATION
4.	3G000285	1	GT 2-SPEED CRANK PLATE FOR 742089 GEARBOX

SPRING BRAKE CONTROL VALVES - SPRING BRAKE PRIORITY

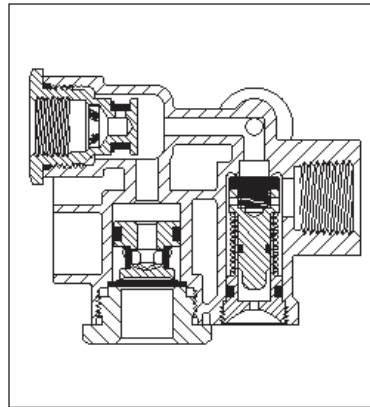
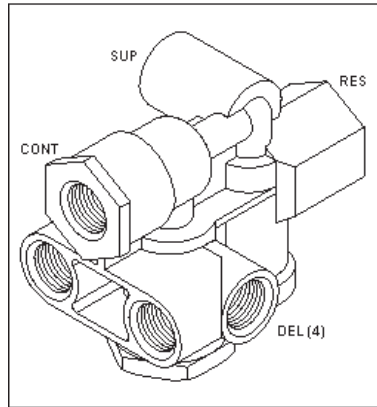

- ◆ The spring brake priority immediately provides supply air to release the spring brakes, the internal Pressure Protection Valve opens to also fill the reservoir at approximately 80 psi.
- ◆ Complies with all changes to FMVSS 121, Docket 90-3 Effective October 8, 1992.
- ◆ Designed for use with a single reservoir on a typical single or tandem axle trailer.
- ◆ May also be used with two 1,400 cubic inch (nominal) reservoirs on tandem axle trailers.
- ◆ Mounting Hardware on page 61 & 62
- ◆ Piping examples on pages 71, 72, 74, 75 & 76.
- ◆ **PLUG UNIT ASSEMBLY 1105815** for pressure protection.
- ◆ **PLUG UNIT ASSEMBLY 110520** for movable seat.
- ◆ **REPAIR KIT 110501**

For complete information view the Sealco website at www.sealcocvp.com

Part Number	PORT SIZES (NPT)				COMMENTS
	Supply	Control	Reservoir	Delivery(4)	
110500	3/8"	3/8"	1/2"	3/8"	None
110505	3/8"	3/8"	1/2"	3/8"	Delivery Back Ports B plugged
110510	3/8"	3/8"	1/2"	3/8"	Delivery Side Ports A plugged

TROUBLESHOOTING GUIDE

Trailer Emergency / Supply For 121 System

CAUTION: Block wheels before servicing trailer air brake system. Drain reservoirs before removing airlines, hoses, valves, or servicing valve plug units. Consult spring brake manufacturer's safety recommendations before working on spring brake chambers.

LEGEND

SBCV = Spring Brake Control Valve

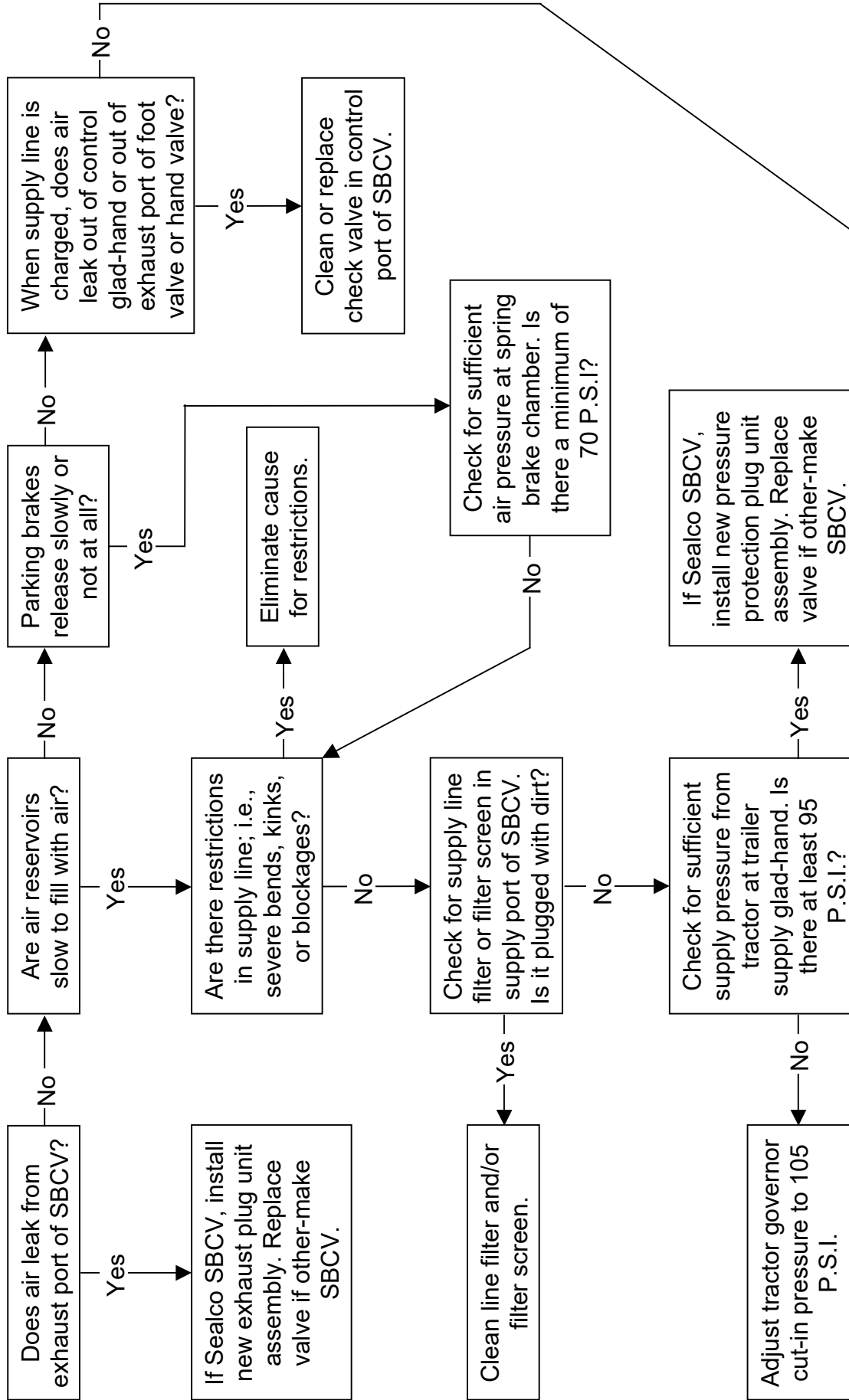

CONTACT your Sealco Regional Manager or Sealco Technical Services at (602) 253-1007

TROUBLESHOOTING GUIDE

Trailer Service / Supply For 121 System

CAUTION: Block wheels before servicing trailer air brake system. Drain reservoirs before removing airlines, hoses, valves, or servicing valve plug units. Consult spring brake manufacturer's safety recommendations before working on spring brake chambers.

LEGEND
 SRV = Spring Relay Valve
 CLV = Control Line Valve
 TPV = Tractor Protection Valve

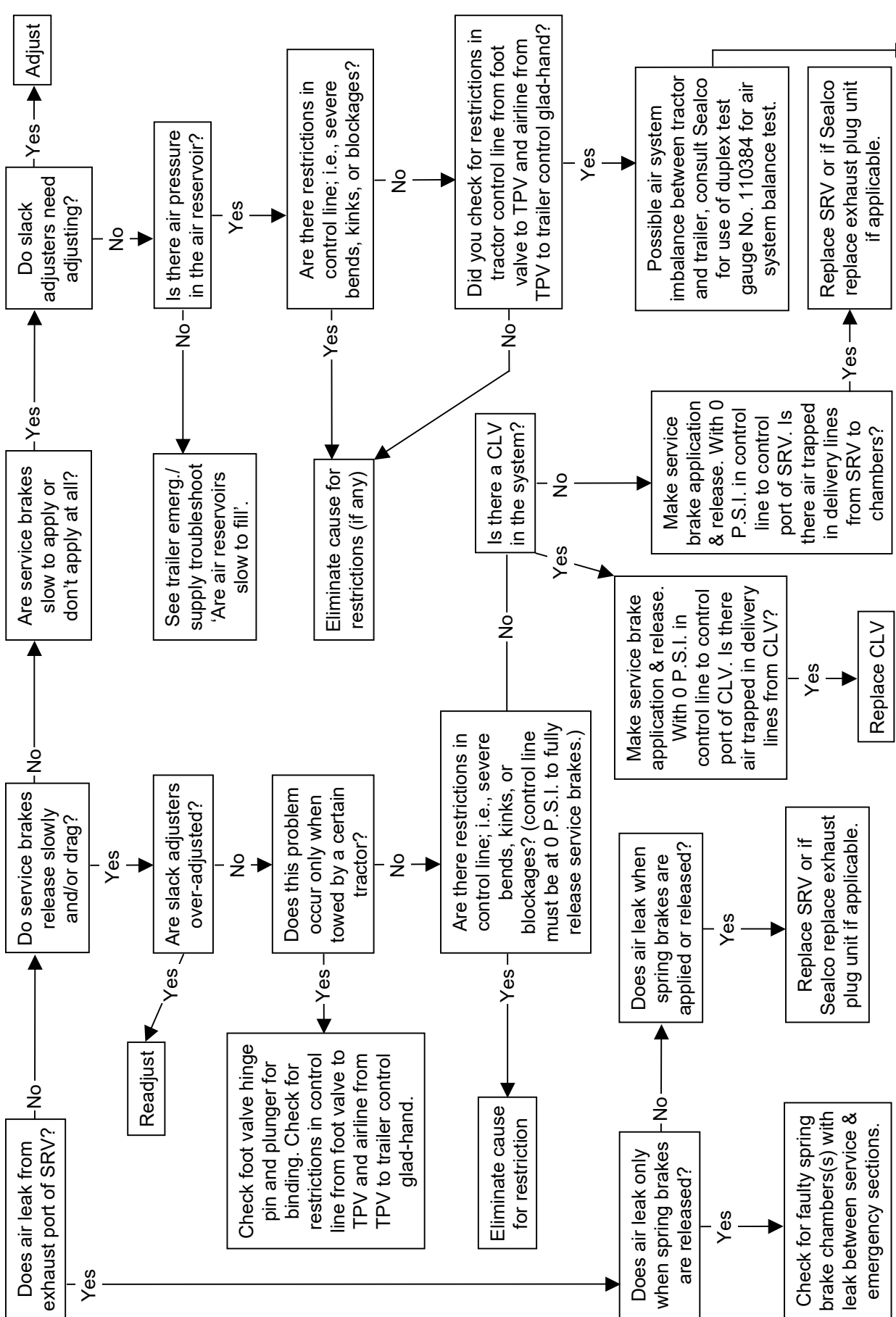

CONTACT your Sealco Regional Manager or Sealco Technical Services at (602) 253-1007

HOW TO BRAKE WITH ABS

Do what good drivers have always been doing: brake just the way you always have.

Apply brakes as normal to stop in time. When your ABS starts working, don't release your brakes, maintain brake pressure.

- ◆ **If driving with a single trailer, doubles or triples...**
Watch your trailer(s) through your mirrors and correct brake pressure as necessary to keep in a straight line.
- ◆ **If only your tractor has ABS...**
Use your rig's brakes as necessary to straighten out your trailer if it swings out. Watch the trailer through your mirrors to make sure it follows your tractor properly.
- ◆ **If only your trailer has ABS...**
Use your rig's brakes as necessary to maintain control and keep your combination in its lane.

Avoid rapid "pumping" of the brakes. During a brake application that could result in a wheel lock. Meritor WABCO ABS automatically releases and applies the brake up to five times per second, obviously much faster than you could do pumping the brake pedal.

Always remember that *you are the most important* element in the safe operation of your vehicle. ABS is not an excuse to take unnecessary risks. Always drive carefully and stay a safe distance away from the vehicle in front of you.

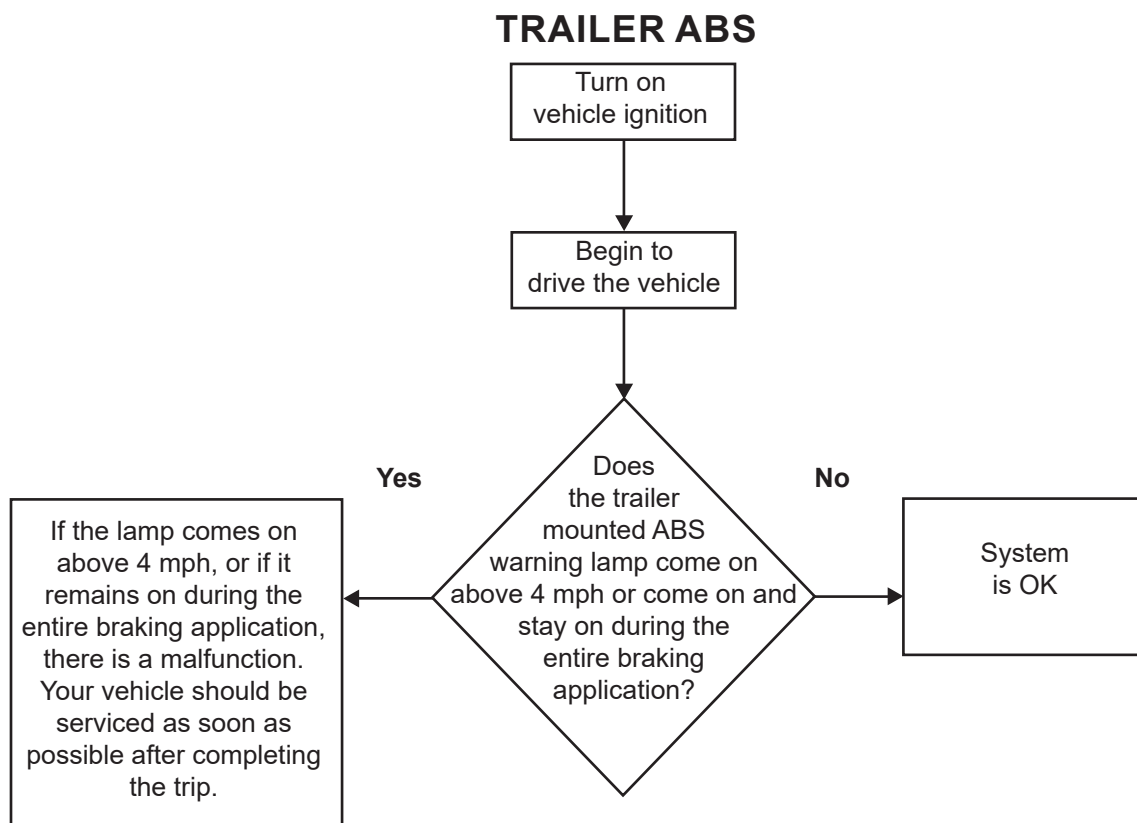

NOTE: Depending how the ABS is powered, the lamp may come on briefly at ignition and then go off, or briefly flash each time you apply the brakes on a moving vehicle.

MERITOR WABCO

Easy-Stop™ and Enhanced Easy-Stop with PLC Trailer ABS Blink Code Diagnostic Guide

**Easy-Stop
2S/1M Basic**
ECU/Modulator Valve Assembly

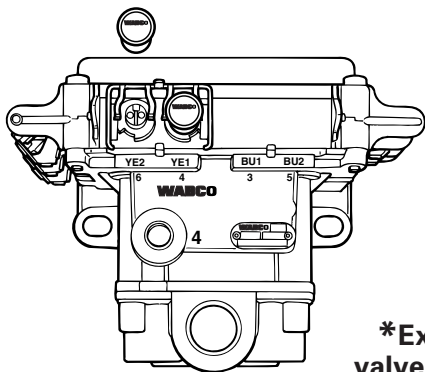

**Easy-Stop 2S/1M,
2S/2M*, 4S/2M*, 4S/3M* Basic**
ECU/Modulator Valve Assembly

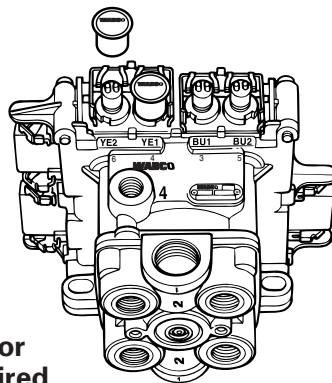

***External modulator
valve and cable required.**

Enhanced Easy-Stop with PLC

**2S/1M Basic ECU/Single
Modulator Valve Assembly**

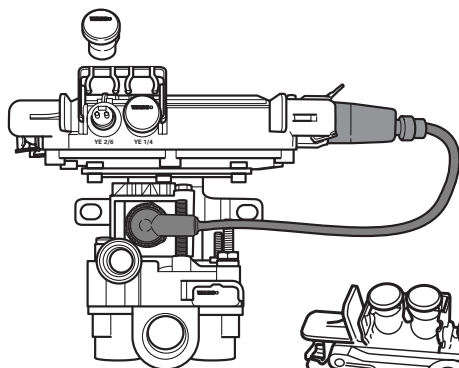

**2S/2M Basic ECU/Dual
Modulator Valve Assembly**

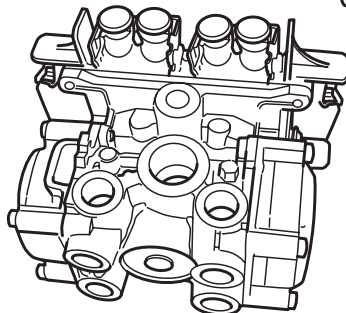
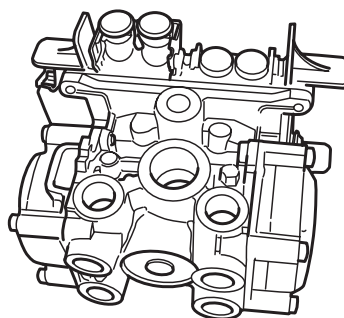

**2S/2M, 4S/2M,
4S/3M* Premium ECU/Dual
Modulator Valve Assembly**

***External modulator valve and cable required.**

This publication covers all Enhanced Easy-Stop ECU/Valve Assemblies and Easy-Stop ECU/Valve Assemblies with serial numbers 3080002746 and higher. For Easy-Stop ECU/Valve Assemblies with serial numbers 3080002745 or lower, please call 1-800-535-5560 for assistance. Serial numbers are located on the bar-code label on the side of the ECU/Valve Assembly.

Typical Sensor Locations

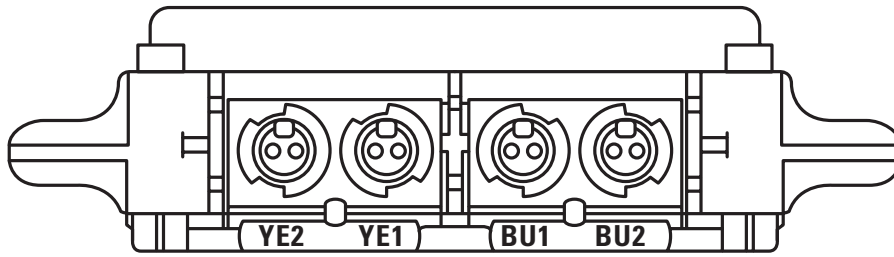

EASY-STOP - 2S/1M

Most Easy-Stop ECUs have a blink code lamp on the top of the ECU. Some early version 2100 Basic ECUs do not have a blink code switch or remote diagnostic tool. Instead, power the ECU, the LED lamp on top of the ECU/Valve Assembly will repeatedly flash the blink code if there is a fault.

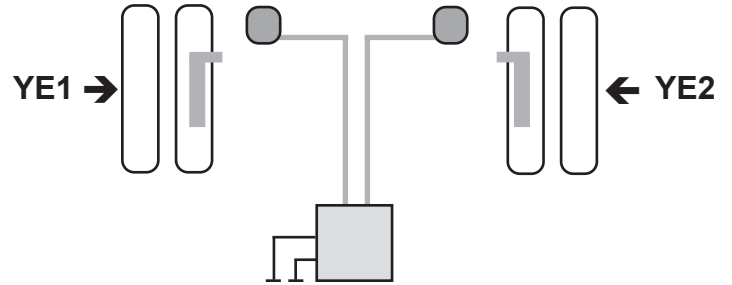

ENHANCED EASY-STOP - 4S/2M

ECU/VALVE ASSEMBLY MTD WITH SENSORS FACING FRONT OF TRAILER

ECU/VALVE ASSEMBLY MTD WITH SENSORS FACING REAR OF TRAILER

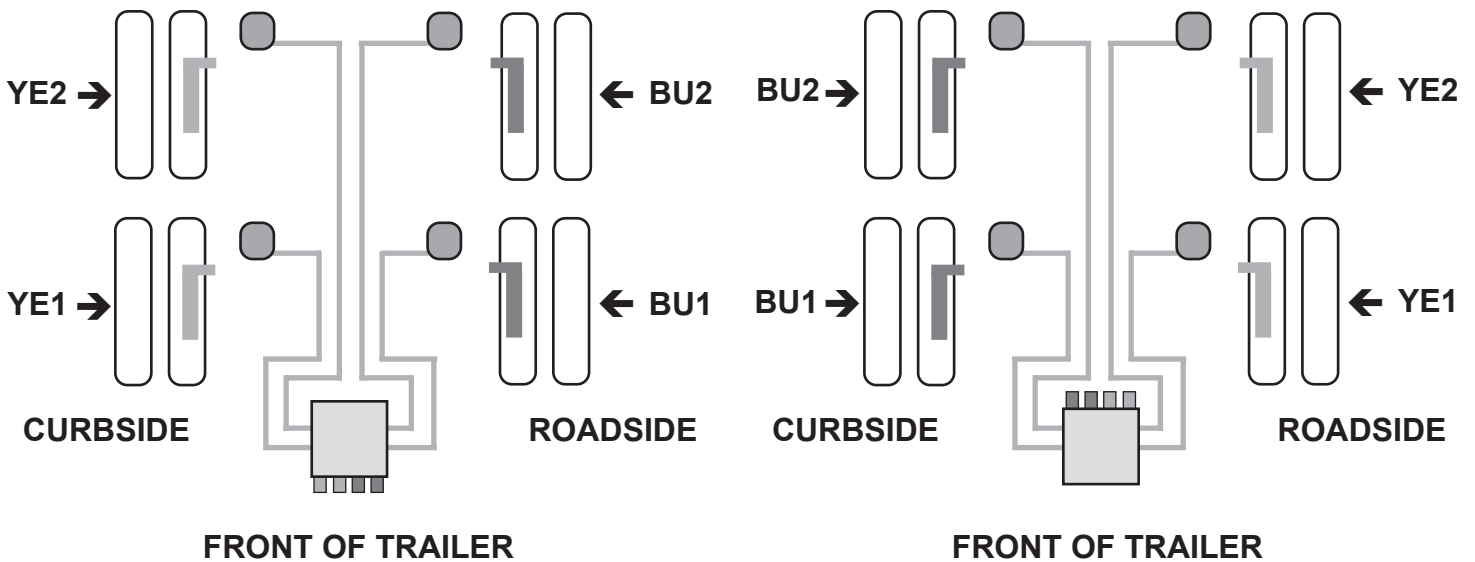

Enhanced Easy-Stop blink codes may be accessed by ignition circuit and counting flashes on the trailer ABS indicator lamp on the side of the trailer.

To access blink codes:

- ◆ Turn ignition ON for one second.
- ◆ Turn OFF for one second,
- ◆ Turn ignition ON and count the flashed on the ABS Lamp.

With Enhanced Easy-Stop, the blink code tool and the ABS Lamp on the trailer do not function simultaneously.

Easy-Stop Troubleshooting and Repair

BLINK CODE	CAUSE OF FAULT	ACTION REQUIRED
0	No faults	System okay. No action required
3	Sensor BU1: Cable break, short circuit or out of adjustment.	Check sensor, sensor cable connection; adjust sensor; or check for excessive hub runout, a sensor gap that is too wide or damage to the tooth wheels.
4	Sensor YE1: Cable break, short circuit or out of adjustment.	Check sensor, sensor cable connection; adjust sensor; or check for excessive hub runout, a sensor gap that is too wide or damage to the tooth wheels.
5	Sensor BU2: Cable break, short circuit or out of adjustment.	Check sensor, sensor cable connection; adjust sensor; or check for excessive hub runout, a sensor gap that is too wide or damage to the tooth wheels.
6	Sensor YE2: Cable break, short circuit or out of adjustment.	Check sensor, sensor cable connection; adjust sensor; or check for excessive hub runout, a sensor gap that is too wide or damage to the tooth wheels.
7	Ext. Modulator (RD): Short to power, cable break or open, short to ground or cable damaged, or ECU/Valve Assembly failure.	Check ABS valve and cable. Replace as required.
9	Easy-Stop: External Modulator (BU) Enhanced Easy-Stop: Internal Modulator Failure, Inlet Valve #2: Short to power, cable break or open, short to ground or cable damaged, or ECU/Valve Assembly Failure.	Easy-Stop: Check ABS valve and cable. Replace as required. Enhanced Easy-Stop: Verify proper installation. If code continues, contact Meritor WABCO for assistance.
10	Easy-Stop: ECU/Valve Assembly Modulator (YE) Enhanced Easy-Stop: Internal Modulator Failure, Inlet Valve #2: Short to power, cable break or open, short to ground or cable damaged, or ECU/Valve Assembly Failure.	Easy-Stop: Check ABS valve and cable. Replace as required. Enhanced Easy-Stop: Verify proper installation. If code continues, contact Meritor WABCO for assistance.
11	Internal Modulator Failure, Outlet Valve. Enhanced Easy-Stop Only.	Verify proper installation. If code continues, contact Meritor WABCO as assistance.
14	Power Supply: Over or under voltage, current low, or internal failure.	Repair vehicle power supply, check vehicle voltage output and connector; check ECU's configuration.
15	ECU – Internal Failure Internal failure.	Internal failure, contact Meritor WABCO.
16	SAE J1708 Failure	Internal failure, contact Meritor WABCO.
17	Generic SAE J2497 Failure	Internal failure, contact Meritor WABCO.
18	Generic I/O Failure	Verify proper electrical installation. Check power supply. Make necessary corrections.

Note: (Easy-Stop only) If the blink code indicates there are no faults, but the trailer ABS indicator lamp continues to come on and stay on when you apply the brakes to the moving vehicle, there is an intermittent fault that must be repaired. Refer to Maintenance Manual 33, *Expert Mode Diagnostics*.

For further information on blink code diagnostics, refer to Maintenance Manual 33 (Easy-Stop),
Maintenance Manual No. 0180 (Enhanced Easy-Stop) or call:
Meritor WABCO at **800-535-5560**.

OPERATION

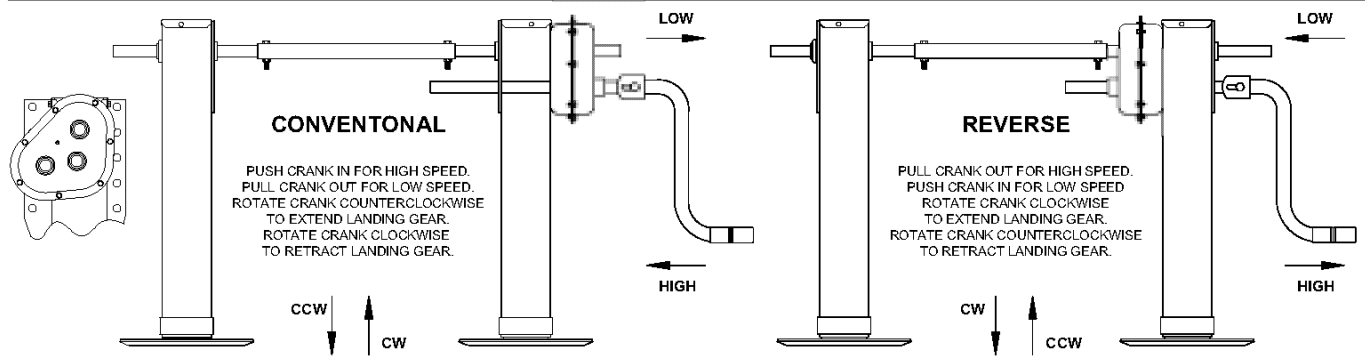

OPERATION Fast Gear

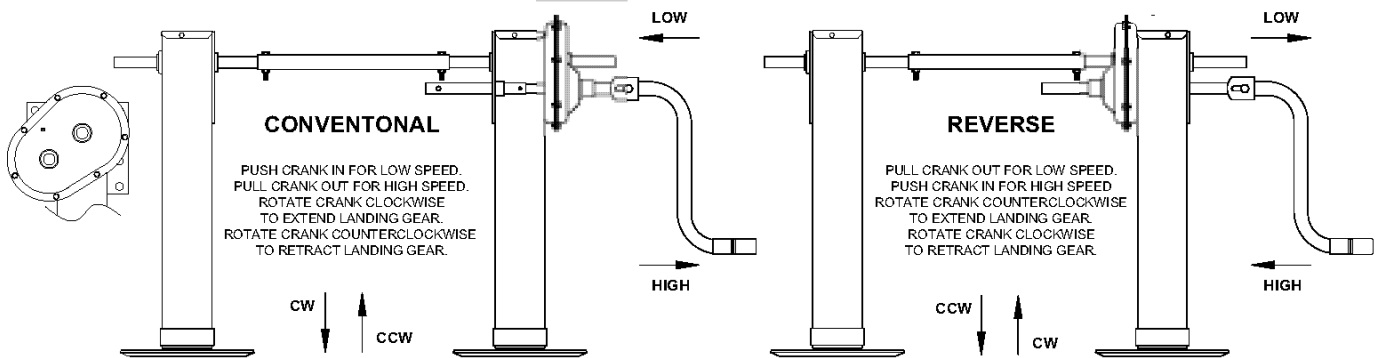

TO REMOVE TRACTOR FROM TRAILER:

1. Position the trailer so that the landing gear shoes will rest on a firm level surface when landing gear is extended.
2. Shift landing gear to high gear and extend landing gear until shoes contact ground.
3. Shift landing gear to low gear and lift trailer approximately (1) inch.
4. Unlock fifth wheel, uncouple air lines, and drive the tractor out from under the trailer.

TO CONNECT TRACTOR TO TRAILER:

1. Ensure that the trailer is at a sufficient height to allow coupling of the tractor and trailer.
2. Connect air lines from tractor to trailer, then lock trailer brakes and back tractor under trailer, then lock fifth wheel.
3. Retract landing gears to fully retracted position.
4. Store crank on the crank holder.

LUBRICATION – STANDARD:

When manufactured, the landing gears have been adequately greased with high quality lubricant. It will be necessary to periodically supplement this lubricant to maintain satisfactory performance. Use a molybdenum type grease with appropriate temperature range for your operating conditions. Gearbox leg has (3) grease fittings; leg without gearbox has (2) grease fittings.

1. Prior to lubrication, extend legs approximately (2) inches from maximum retracted position.
2. For optimum performance, every (6) months lube both legs at all grease fittings.
3. Add 1/4-lb grease at each grease fitting.

LUBRICATION – NoLube:

No additional grease is required.

TROUBLE SHOOTING:

In normal trailer operating service, certain components such as shafts, bushings, bearings, gears, and screw and nut assemblies are subject to wear and will require replacement.

However, under extreme usage condition exceeding AAR-931 Durability Requirements the same components may require replacement more frequently.

Landing gears hard to crank—check the following:

PROBLEM

1. Cross driveshaft in a bind or tight between shafts.
2. To determine which leg turns hard
3. Inadequate lubrication.
4. Alignment.
5. Upper housing or retracting tube may be bent.
6. Screw and nut assembly may have excessive wear and be hard to turn or inoperable.
7. Check for proper clearance between pinion and bevel gear.
8. Excessive wear or damage to pinion, bevel, input, idler and/or output gears.
9. Landing gear jack shafts and/or shift shaft binding.
10. Bent retracting screw.
11. Damaged thrust bearing.
12. Damaged collar.
13. Damaged shift lock boss and/or shaft bearing boss.
14. Weld blow through where strut bracket is welded to housing. (With no-load on landing gear, the retract tube should have free play inside housing.)
15. Impact to jack shaft end has pressed bearing boss into gearbox half.

SOLUTION

- Bolts must be loose and cross driveshaft free to move in slots provided.
- Remove cross driveshaft bolt and crank each leg on the jack shaft.
(See Lubrication Instructions).
- Legs must be timed together, parallel to each other and perpendicular to the trailer crossmembers.
- Replace damaged part.
- Disassemble and inspect for wear. If screw and/or nut show considerable wear, then replace entire retracting tube assembly.
- Minimum end play 1/32".
- Replace damaged gears.
- Check to see if trailer mounting bracket has sufficient size clearance hole to miss landing gear boss or shift shaft.
- Replace entire retracting tube assembly.
- Replace.
- Replace.
- Replace.
- Grind weld as required and re-weld.
- Press boss back into position.

Trouble Shooting/General:

- | | |
|---|--|
| 1. Right-hand leg (gearbox leg) operates but left-hand leg does not move. | Broken cross driveshaft bolt or damaged cross driveshaft. Replace damaged part. |
| 2. Legs will not operate when turning jack shaft. | Damaged pinion or bevel gear. Replace damaged part. |
| 3. Right-hand leg will not operate, shift shaft will turn but jack shaft does not turn. | Damaged input, idler, and/or output gear. Replace damaged part. |
| 4. Leg locked and will not turn. | Bent retracting screw or damaged riser nut and screw. Replace entire retracting tube assembly. |
| 5. Right-hand leg will not stay fully shifted in low gear. | Shift lock ball and shift lock spring missing or damaged shift lock spring. Replace missing or damaged part. |
| 6. Noisy gearbox. | Check that shift shaft movement is 1" when shifted between gears. |

CAUTIONS:

Landing gears are designed to meet T.T.M.A. recommended practice RP-4 and A.A.R.-931 requirements.

When operating the landing gears, it is necessary to observe some cautions. By doing so you will ensure long trouble free service.



1. Do not over extend or over retract landing gears.
2. Never drop trailer on landing gears. Always extend landing gears until sand shoes contact ground, then lift trailer approximately 1 inch before removing tractor from trailer.
3. Always ensure that landing gear shoes or foot pads will rest on a hard ground surface or concrete pad. If necessary, place shoes on a support plank to prevent the landing gears from sinking into the ground surface. (This is especially important with liquid cargo where a shift in the contents could overturn the trailer!).
4. Always retract landing gears fully before moving the trailer.
5. Always store the crank on the crank holder after extending or retracting the landing gear.
6. Replace all damaged or missing parts.
7. Failure to replace worn or damaged riser nut and retracting screw assembly could cause a failure.



GO THE DISTANCE.

HOLLAND USA, INC.
1950 Industrial Blvd. • P.O. Box 425 • Muskegon, MI 49443-0425 • Phone 888-396-6501 • Fax 800-356-3929
www.thehollandgroupinc.com

Copyright © March 2005 • The Holland Group, Inc.

Holland USA, Inc. Facilities:

Dumas, AR Muskegon, MI
Holland, MI Warrenton, MO
Monroe, NC Wylie, TX

Ph: 888-396-6501 Fax: 800-356-3929

Holland International, Inc.

Holland, MI
Phone: 616-396-6501
Fax: 616-396-1511

Holland Hitch of Canada, Ltd.

Woodstock, Ontario • Canada
Phone: 519-537-3494
Fax: 800-565-7753

Holland Equipment, Ltd.

Norwich, Ontario • Canada
Phone: 519-863-3414
Fax: 519-863-2398

Holland Hitch Western, Ltd.

Surrey, British Columbia • Canada
Phone: 604-574-7491
Fax: 604-574-0244

ATLAS 55 Standard - Exploded View

PART NUMBER & DATE
CODE TAG LOCATION

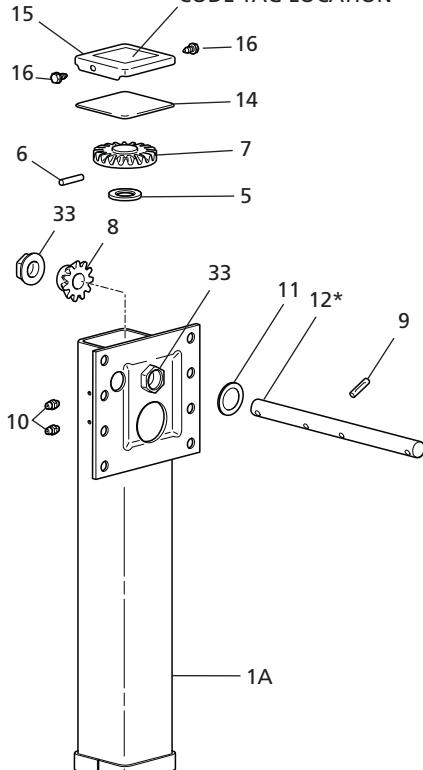

PART NUMBER & DATE
CODE TAG LOCATION

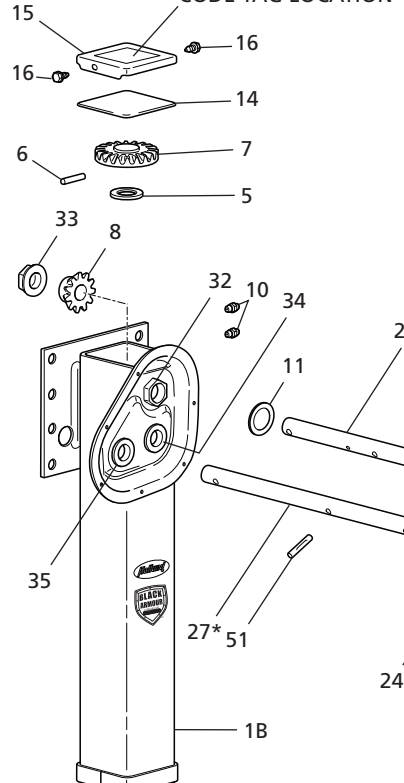

*Models Mfg. prior to January 2013, see page 16.

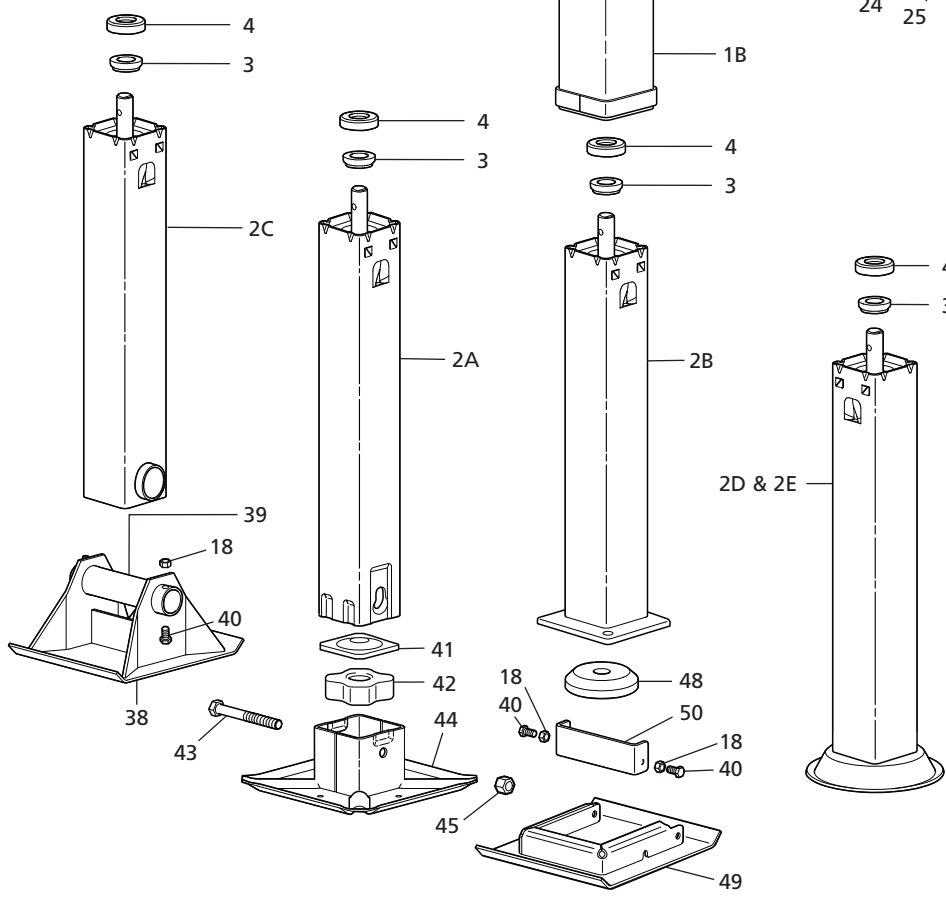

Non-Geared Leg Repair Kit- Universal Shaft (1-speed) RK-11442

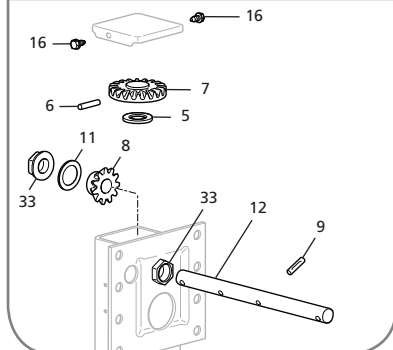

Geared Leg Repair Kit-Universal Shaft (2-speed) RK-11443

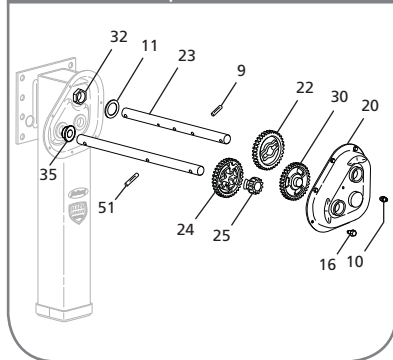

NO.	DESCRIPTION	RETRACT TUBE CODE	TRAVEL					
			13.50"	15.50"	17"	17"CAN.	17" MRL	19"
2A	Retract Tube - RCF	0 or 5 (MRL)	LG3053-01	LG3053-02	LG3053-04	N/A	LG3053-03	LG3053-05
2B	Retract Tube - Low Profile RCF	0	LG3097-01	LG3097-02	LG3097-03	N/A	N/A	NA
2C	Retract Tube - Axle	0	LG3012-01	LG3012-02	LG3012-03	N/A	N/A	LG3012-04
2D	Retract Tube - Shockfoot 10" DIA	0,6 (CAN) or B	LG3061-02	LG3061-03	LG3061-04	LG3061-07	LG3061-10	LG3061-13
2E	Retract Tube - Shockfoot 12" DIA	0,6 (CAN) or B	LG3061-01	N/A	LG3061-05	LG3061-08	LG3061-11	LG3061-14

NO.	DESCRIPTION	PART NO.	SPEED	
			ONE	TWO
1A	Upper Housing LH	N/A	-	-
1B	Upper Housing RH	N/A	-	-
3	Collar	XB-LG0544	1	1
4	Thrust Bearing	XB-BRG-013-77	1	1
5	Washer - FL 2"OD x 1.19" ID x .13" THK	XB-PW-016-62	1	1
6	Pin - DIA .38" x 2"	XA-CRP-V-06635	1	2
7	Bevel Gear	LG2884	1	1
8	Pinion Gear	LG1823-02	1	1
9	Groove Pin - DIA .38" x 1.50"	XB-GP-014-18	1	1
10	Ftg - Grease .25"-28 Self Tapping	XB-GRF-022-16	2	3
11	O-Ring, #319	2024100000100	1	1
12	Jack Shaft LH - Universal Mount	LG2964-01	1	-
	- I-Beam Mount, 6.50"	LG2964-04	1	-
	- I-Beam Mount, 10.00"	LG2964-05	1	-
	- Conventional Mount	LG2964-02	1	-
	- Reverse Mount	LG2964-03	1	-
13	Pin - Spring DIA .25" x 1.5" (Not Required)	N/A	-	-
15	Top Cover	2111100004080	1	1
16	Self-Tapping Screw .25"-20 x .5" Lg	XB-ST5-008-11	2	9
17	Screw, Hex Cap .38"-16 x 2.25" Lg GR5	XB-HHC-050-42	1	2
18	Self-Locking Nut .38"-16 - Sandshoe	XB-SLN-012-04	2	3
	- Low Profile RCF	XB-SLN-012-04	3	4
	- RCF		1	2
19	Washer .38" Std Type A	XB-PW-016-03	-	2
20	Gearbox Half, Outside w/Hole for Grease Fitting	LG2996	-	1
22	Output Gear	LG2980	-	1
23	Jackshaft RH - Universal Mount	LG2963-01	-	1
	- I-Beam Mount, 6.50"	LG2963-04	-	1
	- I-Beam Mount, 10.00"	LG2963-05	-	1
	- Conventional Mount	LG2963-02	-	1
	- Reverse Mount	LG2963-03	-	1
24	Gear, Drive, High Speed - Machined	2040100000060	-	1
25	Gear, Drive, Low Speed - Machined	2040100000050	-	1
26	Groove Pin, Type E DIA .38" x 2.00" Lg	XB-GP-052-21	-	1
27	Shift Shaft - Universal	2111100003400	-	1
	- I-Beam & Conventional	2111100003410	-	1
	- Reverse	2111100003420	-	1
30	Idler Gear	LG2975	-	1
32	Boss, Hex Lock - Oversized	2022100000180	-	1
33	Hex Lock Boss - Sealed	LG2926-10	2	1
34	Idler Shaft Bushing (Included in Item #23)	LG3005	-	2
35	Boss Bearing - Sealed (Included in Item #20)	LG0659-10	-	3

NO.	DESCRIPTION	PART NO.	SPEED	
			ONE	TWO
38	Sandshoe - 10" x 10" x 4.50"	50616001	1	1
	- 10" x 12" x 4.50"	50616000	1	1
	- 10" x 10" x 2.00"	50616008	1	1
	- 10" x 12" x 2.00"	50616007	1	1
39	Sandshoe Axle - Hollow Axle 8.50" Lg	LG0070-02	1	1
40	Screw, Hex Cap .38"-16 x .75" Lg GR5 - Sandshoe	XB-HHC-050-69	1	1
	Screw, Hex Cap .38"-16 x .75" Lg GR5 - Low Profile RCF	XB-HHC-050-69	2	2
41	Cushion Foot Plate	LG0725	1	1
42	Cushion Foot Rubber	XB-LG0726	1	1
43	Bolt - Hex Head .63" -11 x 5.50"	XB-HHB-050-70	1	1
44	R.C.F. - DIA 10"	LG0718-01	1	1
	- DIA 12"	LG0740-01	1	1
	- 10" x 10"	LG0732-01	1	1
45	Self-Locking Nut - .63"-11"	XB-SP0012-10	1	1
48	Cushion Foot Pad - Low Profile RCF	728003	1	1
49	Interchangeable Collar - Low Profile RCF	730640	1	1
50	Interchangable Strap	730638	1	1
51	Pin Groove, .31" Dia. x 2.00" Lg	XB-GP-052-52	-	1

For technical assistance please go to www.safholland.us or call 800.876.3929



MECHANICAL SUSPENSION

INSTALLATION AND MAINTENANCE INSTRUCTIONS



DuraLite® Series

Installation, Maintenance and Warranty Information



CONTENTS

	Page		Page
General Information	2	Install Straddle Mount Hanger Brackets	6
Notes, Cautions and Warnings	2	Weld Axle Seats to Axle(s)	7
Installation Preparation	2	Assemble Torque Arms and Leaf Springs	8, 9
Warranty	2	Axle Alignment Instructions	10
Locate Hanger Brackets	3	Final Inspection	10
Install Under Mount Hanger Brackets	4	Maintenance recommendations	11
Install Flange Mount Hanger Brackets	5	Leaf Spring Selection	12
		Mounting Height Spring Seat Selections	12

GENERAL INFORMATION

The DuraLite suspension is available in three hanger bracket mounting styles: straddle mount, under mount and flange mount. The DuraLite suspension may be used as a single axle, tandem axle or triple axle. The base suspension is the single axle – adding a multi-axle conversion kit converts the single axle to a tandem and a second multi-axle kit will make a triple axle suspension. The DuraLite suspension is available in overslung (axle below the spring) or underslung (axle above the spring) configuration.

The following instructions provide the minimum requirements for installing the Holland DuraLite® suspension. It is the responsibility of the installer to determine the proper location of the suspension, to provide an adequate structure to support the suspension, to insure adequate clearances with other components and to determine if the rated capacity is adequate for the applications.

NOTES, CAUTIONS AND WARNINGS

You must read and understand all of the safety procedures presented in this manual before starting any work on the suspension.

Proper tools must be used to perform the maintenance and repair procedures described in this manual. Many of these procedures require special tools.

Failure to use the proper equipment could result in personal injury and/or damage to the suspension.

Safety glasses must be worn at all times when performing the procedures covered in this manual.

Throughout this manual, you will notice the terms “NOTE,” “IMPORTANT,” “CAUTION” and “WARNING” followed by important product information. So that you may better understand the manual, those terms are as follows:

NOTE: Includes additional information to enable accurate and easy performance of procedures.

IMPORTANT: Includes additional information that if not followed could lead to hindered product performance.

CAUTION Used without the safety alert symbol, indicates a potentially hazardous situation which, if not avoided, may result in property damage.

▲ CAUTION Indicates a potentially hazardous situation which, if not avoided, may result in minor or moderate injury.

▲ WARNING Indicates a potentially hazardous situation which, if not avoided, could result in death or serious injury.

INSTALLATION PREPARATION

The proper installation of the suspension is critical to assure trouble free operation. Before proceeding with suspension installation, check the tire size and trailer design to make sure that there is lateral tire clearance and a vertical tire clearance of at least 4½” when the trailer is empty. Vertical tire clearance may be adjusted by using different height spring seats or high, medium or low arch springs. Holland DuraLite suspensions are rated at 22,400 pounds GAWR (Gross Axle Weight Rating) with one, two or three leaf springs and 24,000 pounds GAWR with heavy duty leaf springs. (Holland does not supply springs.) For leaf spring selection and mounting height information, *see Tables 1, 2 and 3 on page 12.* Check that adequate clearance is provided to all components of the trailer, including but not limited to tires, brakes and air lines.

IMPORTANT: The suspension hangers must be on the same centers as the spring seats and springs, within the tolerances shown. The springs must be square with the axles and located the same distance from the axle centerline within the tolerances shown.

Failure to correctly install the components can lead to the following trailer problems: trailer lean, improper tracking, premature tire wear and shortened suspension life. Failure to comply with these installation instructions without written permission will void the suspension warranty.

WARRANTY

Refer to the complete warranty for the country in which the product will be used. A copy of the written warranty is included with the product as well as on the Holland Group web site (www.thehollandgroupinc.com).

It may also be ordered directly from the address shown on the back cover.

LOCATE HANGER BRACKETS (ALL STYLES) ON TRAILER FRAME

NOTE: The hanger bracket location instructions on this page are to be used for all 3 hanger bracket styles; under mount, flange mount and straddle mount. After the hanger brackets have been properly located and tack welded to the trailer frame, proceed to Page 3 for Under Mount, Page 4 for Flange Mount or Page 5 for Straddle Mount installation instructions.

1. Identify and mark hanger bracket locations on bottom of trailer frame referencing the dimensions provided in **Figure 1** (single axle) or **Figure 2** (tandem axle) or **Figure 3** (triple axle). Hanger spacing is always measured from center line to center line of hanger (**Figure 1**). The front and rear hangers are always located an equal distance from the center hanger and should not vary from dimension shown more than plus or minus $1/16''$. Hangers must be located on both sides of sub-frame in exactly the same distances from front and rear of trailer frame. Hangers on one side of sub-frame must not be in front of or behind corresponding hangers on other side of sub-frame by more than plus or minus $1/16''$.

IMPORTANT: Frame surface where hanger brackets are to be attached must be clean and free of any surface rust. Use wire brush or light-duty grinder to clean surface.

2. Position hanger brackets on frame according to location marks determined in **Step 1**. Position and tack weld all hangers in position and double check dimensions before completing welding of hangers (**Figure 1**, **Figure 2** and **Figure 3**).
3. DuraLite suspension hangers may be installed with any low hydrogen welding process compatible with high strength low alloy steel, such as AWS A5.18 ER70xx, SMAW or flux cored welding. Use a low hydrogen process for all welds, including tack welds. Make sure the weld process is compatible with the trailer structure.

IMPORTANT: Hangers must be mounted in proper alignment with one another and must not be cocked or tilted in respect to the sub frame mounting surface.

Figure 1 (Under mount style shown)

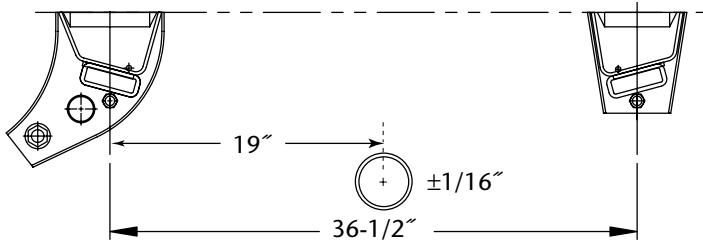

Figure 2 (Under mount style shown)

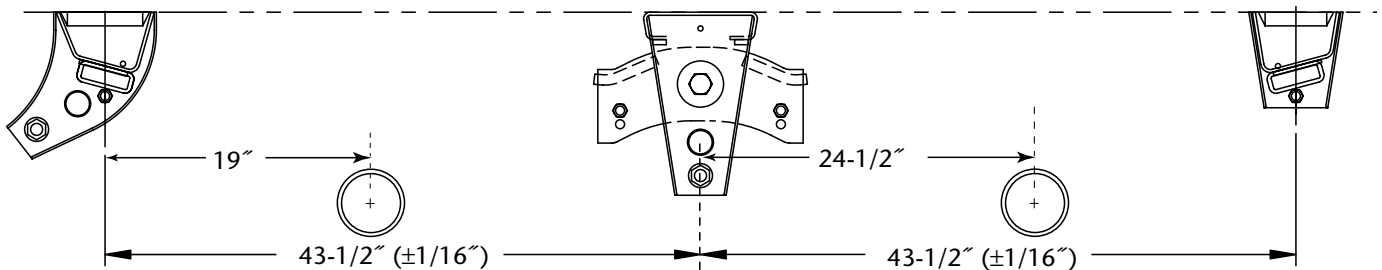
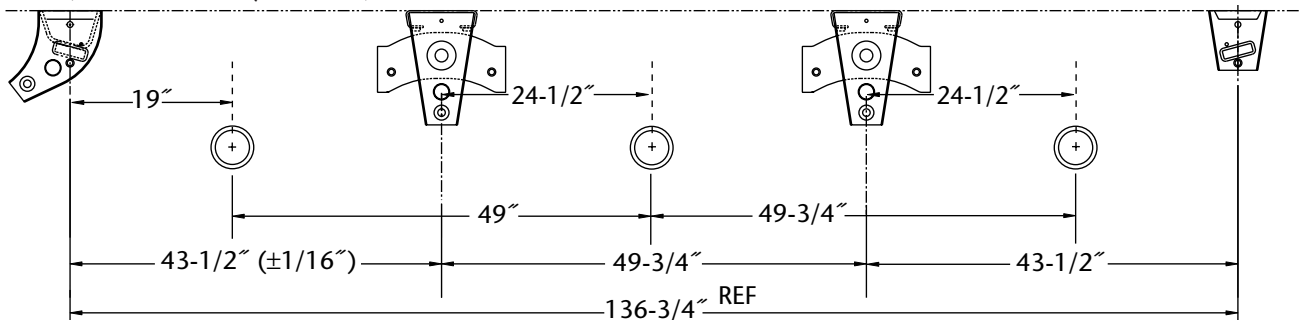

Figure 3 (Under mount style shown)



INSTALL UNDER MOUNT STYLE HANGER BRACKETS

IMPORTANT: The under mount style hanger brackets must be located on the trailer frame to match the axle spring center (Figure 4).

1. Install a 1¼ inches schedule 40 pipe or 1.66 OD x .109 standard mechanical tubing through the front and center hangers. The pipe brace should be 6 inches longer than the spring centers. Tack weld the pipe brace in place (Figure 4).

2. Add diagonal braces between the front, center and rear hangers and the frame of the trailer (Figure 4).
3. Check that all components are located in the correct position. Weld the suspension hangers in place as shown in Figures 5a, 5b and 5c. Weld the pipe braces and diagonal braces in place as shown in Figure 4.

Figure 4

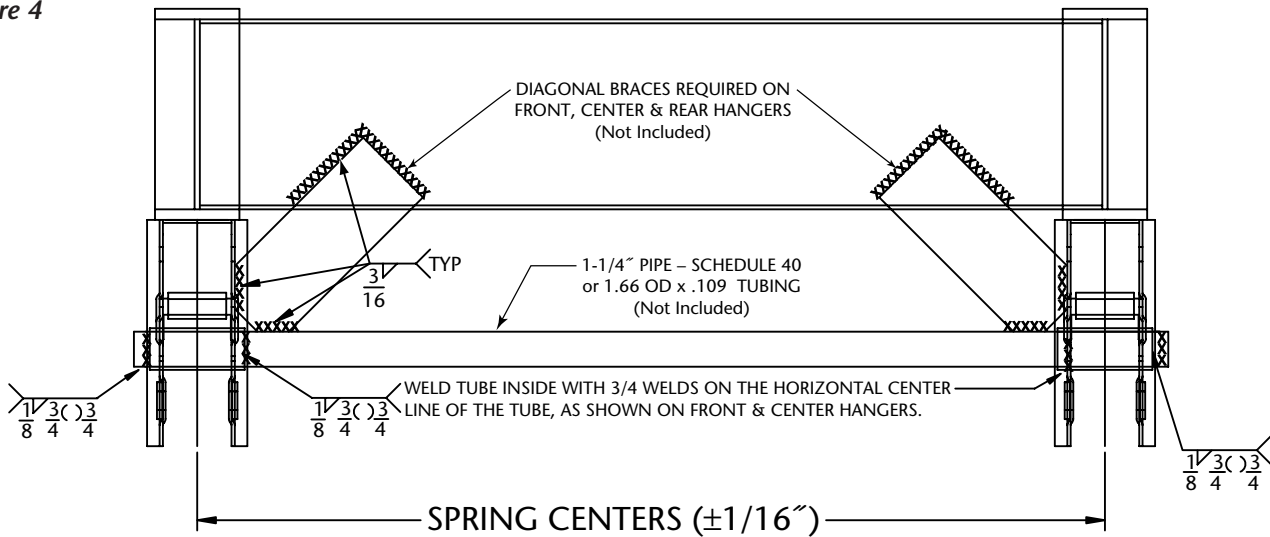

Figure 5a

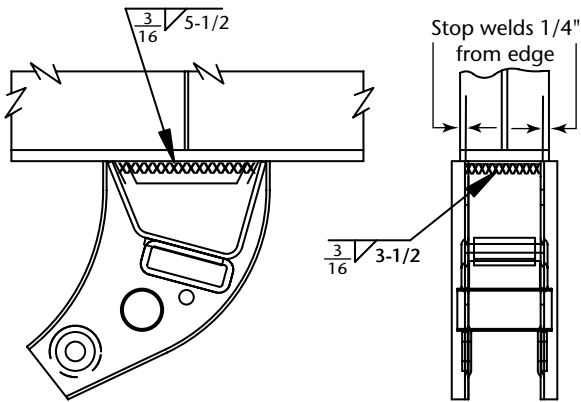

Figure 5b

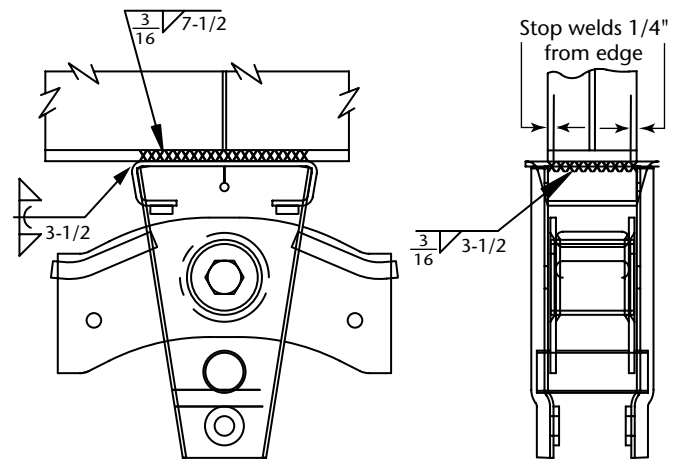
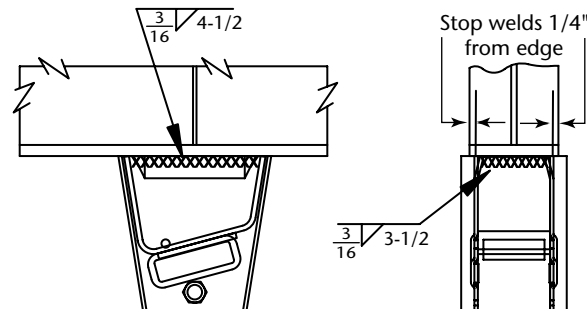

Figure 5c



INSTALL FLANGE STYLE HANGER BRACKETS

1. Install a 1¼ inches schedule 40 pipe or 1.66 OD x .109 standard mechanical tubing through the front and center hangers. The pipe brace should be 6 inches longer than the spring centers. Tack weld the pipe brace in place (*Figure 4*).
2. Add diagonal braces between the front, center and rear hangers and the frame of the trailer (*Figure 4*).
3. Check that all components are located in the correct position. Weld the suspension hangers in place as shown in *Figures 5a, 5b* and *5c*. Weld the pipe braces and diagonal braces in place as shown in *Figure 4*.

Figure 4

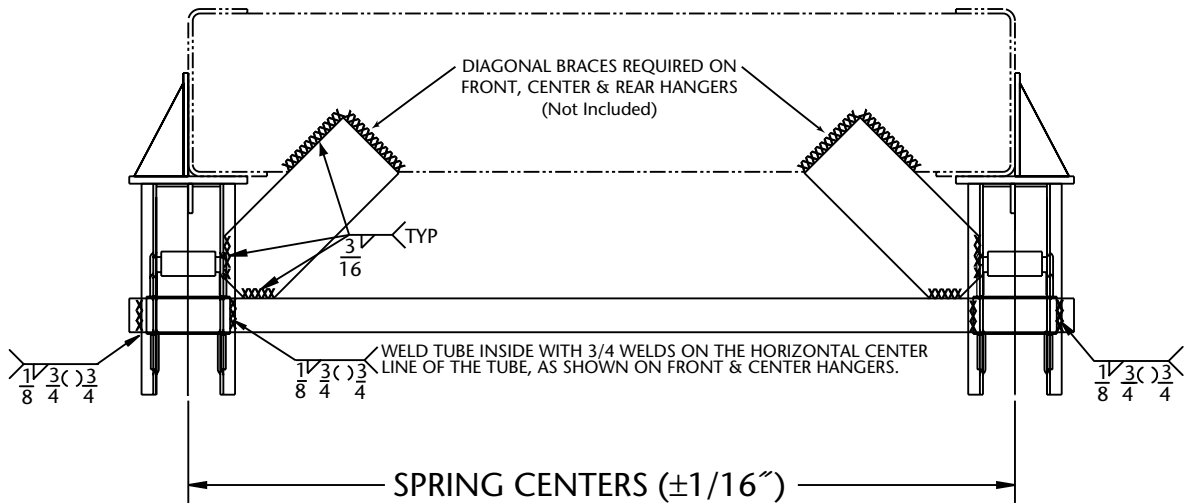

Figure 5a

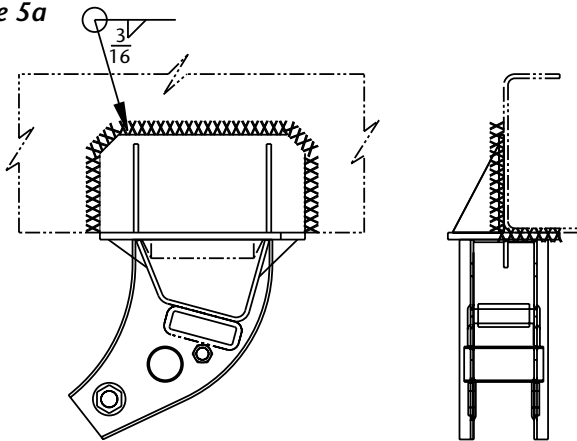

Figure 5b

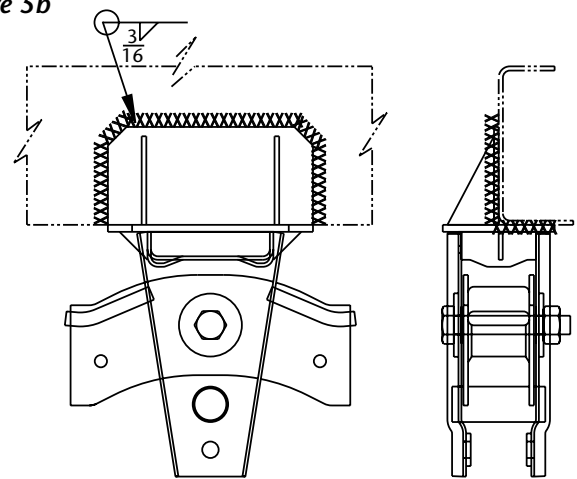
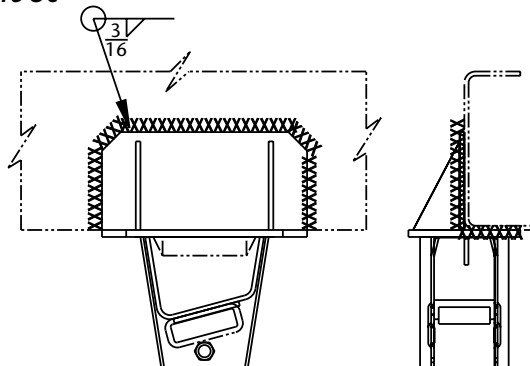

Figure 5c



INSTALL STRADDLE STYLE HANGER BRACKETS

1. Install a 1¼ inches schedule 40 pipe or 1.66 OD x .109 standard mechanical tubing through the front and center hangers. The pipe brace should be 6 inches longer than the spring centers. Tack weld the pipe brace in place (Figure 4).

2. Check that all components are located in the correct position. Weld the suspension hangers in place as shown in Figure 5a, 5b and 5c. Weld the pipe braces in place as shown in Figure 4.

Figure 4

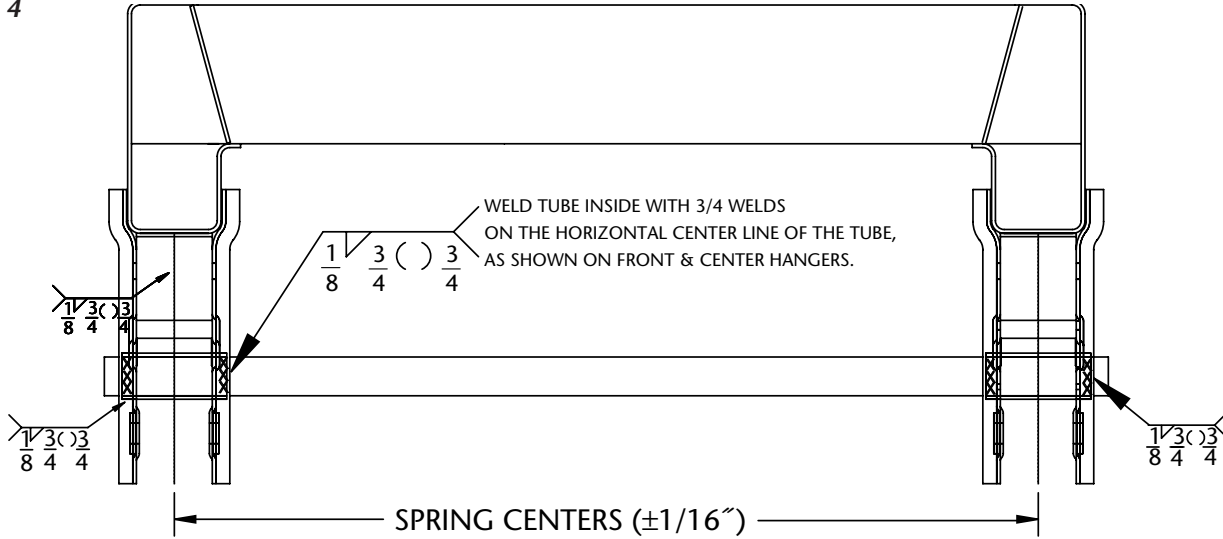
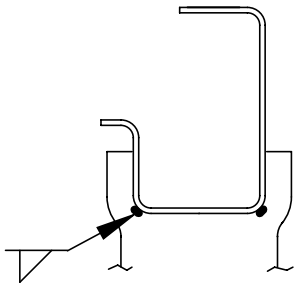
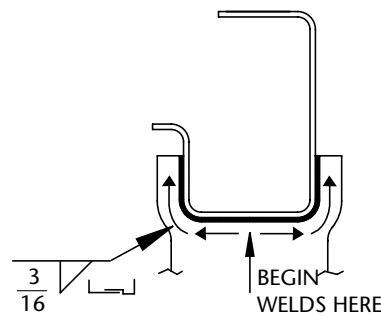

Figure 5



WELD NO. 1
TACK WELD 4 PLCS PER HANGER

Figure 5b



WELD NO. 2
TYP 2 PLCS PER HANGER
(WELDS MUST BE CONTINUOUS - DO NOT STOP AND RESTART)

Figure 5c

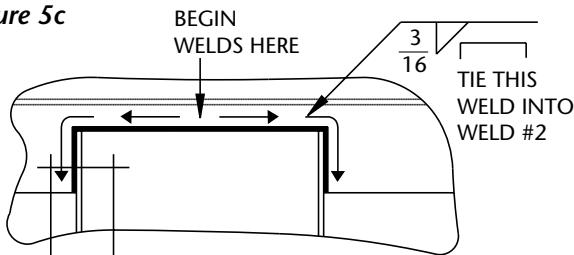

WELD NO. 3
TYP 2 PLCS PER HANGER
(WELDS MUST BE CONTINUOUS - DO NOT STOP AND RESTART)

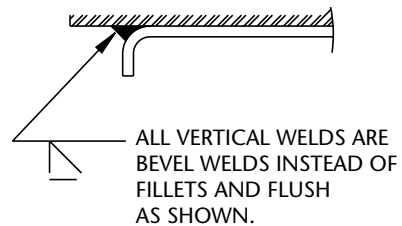

SECTION C-C
TYP 12 PLCS

WELD AXLE SEATS TO AXLE(S)

IMPORTANT: The axle seats and bottom plates that are welded to the axle are compatible with all low hydrogen welding processes suitable for welding to steel axles.

NOTE: See below for underslung axle style instructions.

OVERSLUNG AXLE STYLE

1. The axle seats should be located on the spring centers within $\pm 1/16"$. The axle seats should be the same distance from the center of the axle within the same tolerance. The camshaft should be oriented per the axle manufacturers specification. (**NOTE:** When the cams are forward, the cam must be below the horizontal centerline when axle seats of 2" or shorter height are used.)
2. Clamp the axle seats and bottom plates to the axle. Check that any gap between the axle seat riser and the axle, and the bottom plate and the axle does not exceed $1/8"$ (Figure 6). If a greater gap is present, these parts may be clamped to the axle or adjusted to fit by grinding the axle seat. Using the axle manufacturer's recommendations, weld the axle seats and bottom plates to the axles (Figure 7).

Figure 6 Proper Bottom Plate to Axle Fit

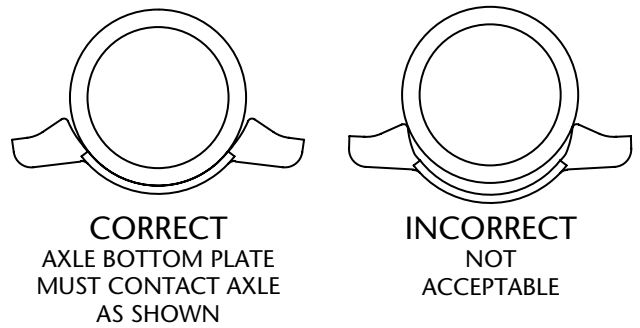

Figure 7 Axle Weld Specifications

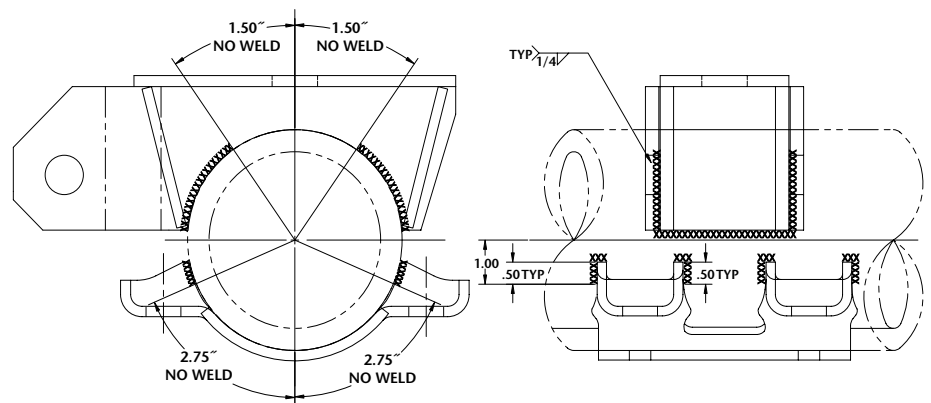

Figure 8 Proper Axle Seat to Axle Fit

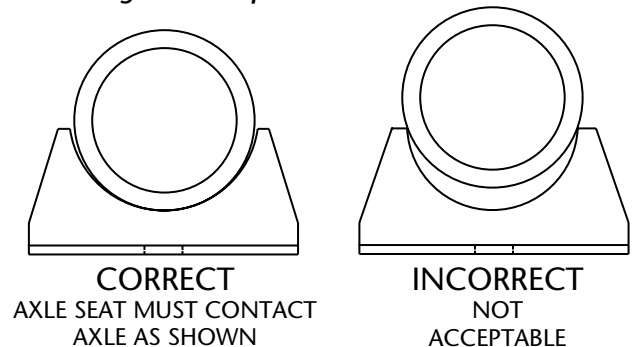
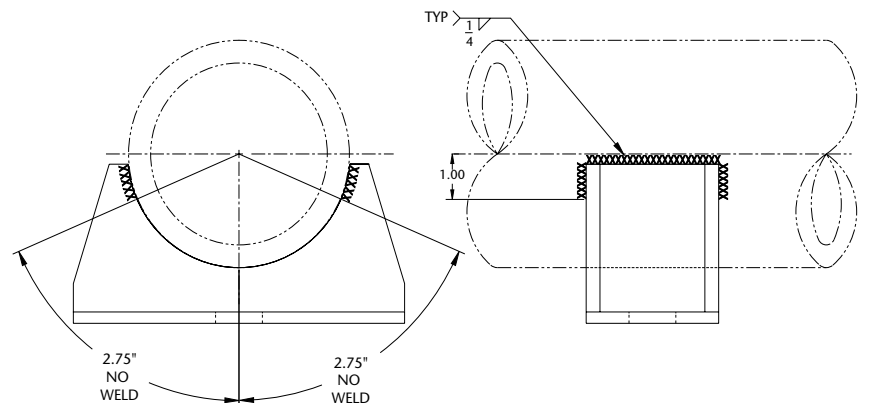

Figure 9 Axle Weld Specifications



UNDERSLUNG AXLE STYLE

1. The axle seats should be located on the spring centers within $\pm 1/16"$. The axle seats should be the same distance from the center of the axle within the same tolerance. The camshaft should be oriented per the axle manufacturers specification. (**NOTE:** When the cams are forward, the cam must be below the horizontal centerline when axle seats of 2" or shorter height are used.)
2. Clamp the axle seats to the axle. Check that any gap between the axle seat riser and the axle does not exceed $1/8"$ (Figure 8). If a greater gap is present, the axle seats may be clamped to the axle or adjusted to fit by grinding. Using the axle manufacturer's recommendations, weld the axle seats to the axles (Figure 9).

ASSEMBLE TORQUE ARMS AND LEAF SPRINGS

OVERSLUNG AXLE STYLE

Proceed to Page 8 for Underslung axle style instructions.

NOTE: It is recommended, but not required, to install the fasteners with the nuts on the outside (closest to tires). Lubrication may be used on all threaded fasteners, but is not required unless the fasteners have minor surface rust.

Install Torque Arms and Springs

1. Install the spring liner supplied with the springs, on top of the springs. Place the springs on top of the spring seats on the axle (*Figure 10*). Place the top plate on top of the spring. Install the springs on the axles with the appropriate U-bolts, nuts and washers. The U-bolts will fit into the detents stamped into the top plate (*Figure 10*). The U-bolt threads may be lubricated before tightening the U-bolts.

IMPORTANT: On tandem axle suspensions the big hook end of the spring should be arranged to fit in the equalizer (*Figure 11a*). On single axle suspensions it should point to the rear (*Figure 11*). Arrange the springs so that they are on the correct centers ± 0.03 inches and perpendicular to the axle.

2. Tighten the U-bolts to 275 to 300 foot pounds of torque using an alternating pattern (*Figure 10a*). Check the spring centers and adjust if necessary.

CAUTION DO NOT directly strike the springs with a steel hammer; use a rubber hammer or wooden block to avoid damaging the springs.

3. Install the axles with springs into the suspension hangers. Install the 5/8 inch spring retainer bolts and spacers in the front and rear hangers, and the equalizer on tandem axles to hold the springs in place. Tighten these 5/8 inch bolts to 35 to 50 foot pounds (*Figure 11*).

CAUTION DO NOT overtighten as this may damage the spacers.

4. Install the torque arms between the hangers and the spring seats on the axles. It is recommended that the adjustable torque arms be installed on the road side and the fixed (cast) torque arms be installed on the curb side (*Figure 12*). Install the 7/8 inch nuts and bolts to secure the torque arms in place and torque to 275 to 300 foot pounds (*Figure 12*).

5. With the suspension installed, check that there is $(1/8" \pm 3/32")$ clearance between the springs and the sides of the hangers and that all the springs are contacting the bottoms of the hangers (*Figure 12a*).

6. Install the decal, XB-SP0001 in clear view on the road side of the vehicle as close as practical to the suspension.

Figure 10

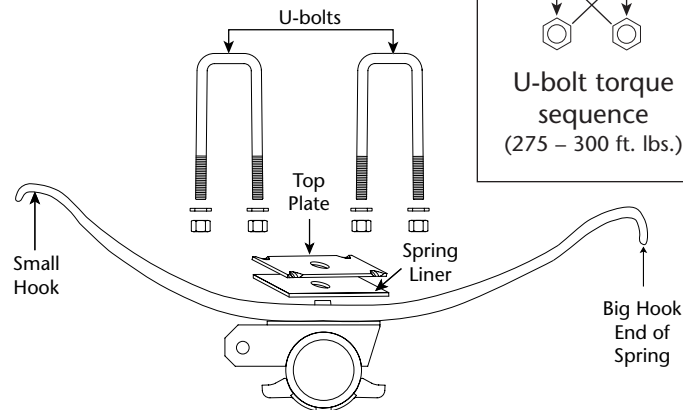

Figure 10a

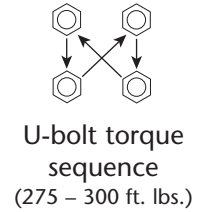

Figure 11

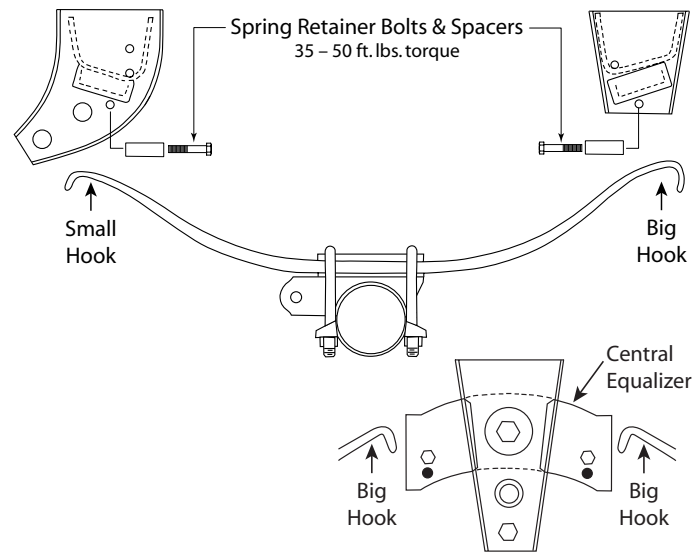

Figure 11a

Figure 12

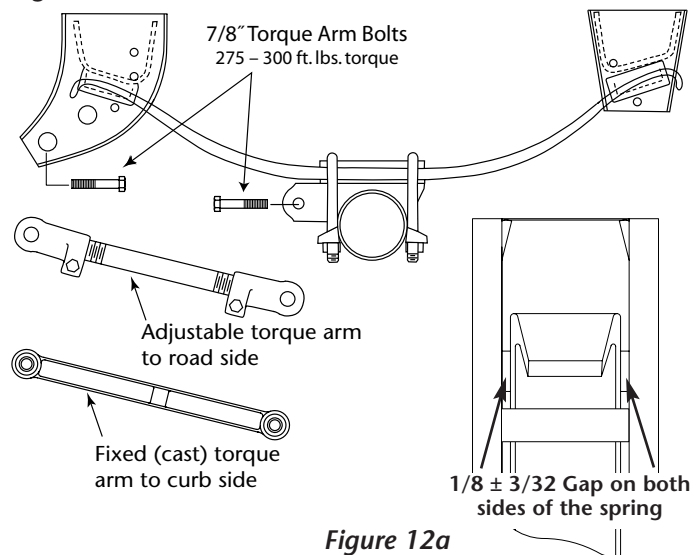

Figure 12a

ASSEMBLE TORQUE ARMS AND LEAF SPRINGS

UNDERSLUNG AXLE STYLE

NOTE: It is recommended, but not required, to install the fasteners with the nuts on the outside (closest to tires). Lubrication may be used on all threaded fasteners, but is not required unless the fasteners have minor surface rust.

Install Torque Arms and Springs

1. Install the spring liner supplied with the springs, on top of the springs. Position the springs under the spring seats on the axle (Figure 10). Position the bottom plate under the spring. Assemble the springs to the axles with the appropriate U-bolts, nuts and washers. The U-bolt threads may be lubricated before tightening the U-bolts.

IMPORTANT: On tandem axle suspensions the big hook end of the spring should be arranged to fit in the equalizer (Figure 11a). On single axle suspensions it should point to the rear (Figure 11). Arrange the springs so that they are on the correct centers $\pm .03$ inches and perpendicular to the axle.

2. Tighten the U-bolts to 275 to 300 foot pounds of torque using an alternating pattern (Figure 10a). Check the spring centers and adjust if necessary.

CAUTION DO NOT directly strike the springs with a steel hammer; use a rubber hammer or wooden block to avoid damaging the springs.

3. Install the axles with springs into the suspension hangers. Install the 5/8" spring retainer bolts and spacers in the front and rear hangers, and the equalizer on tandem axles to hold the springs in place. Tighten these 5/8" bolts to 35 to 50 foot pounds (Figure 11).

CAUTION DO NOT overtighten as this may damage the spacers.

4. Install the torque arms between the hangers and the bottom plates on the axles. It is recommended that the adjustable torque arms be installed on the road side and the fixed torque arms be installed on the curb side (Figure 12). Install the 7/8" nuts and bolts to secure the torque arms in place and torque to 275 to 300 foot pounds (Figure 12).

5. With the suspension installed, check that there is ($1/8" \pm 3/32"$) clearance between the springs and the sides of the hangers and that all the springs are contacting the bottoms of the hangers (Figure 12a).

6. Install the decal, XB-SP0001 in clear view on the road side of the vehicle as close as practical to the suspension.

Figure 10

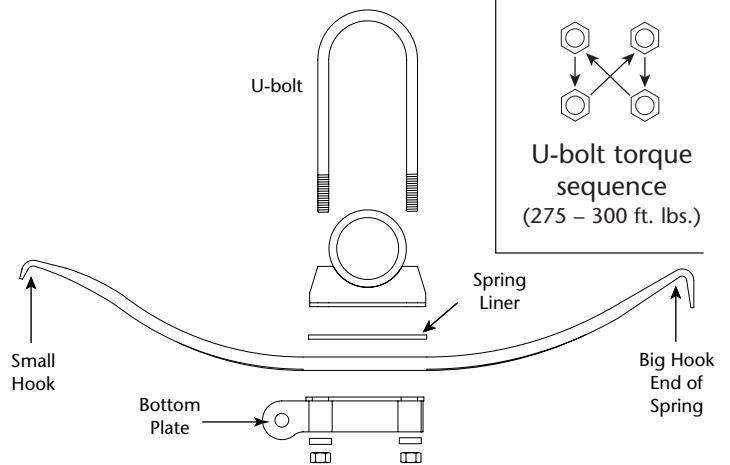

Figure 10a

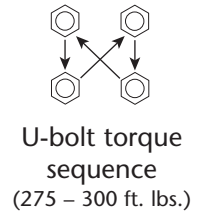

Figure 11

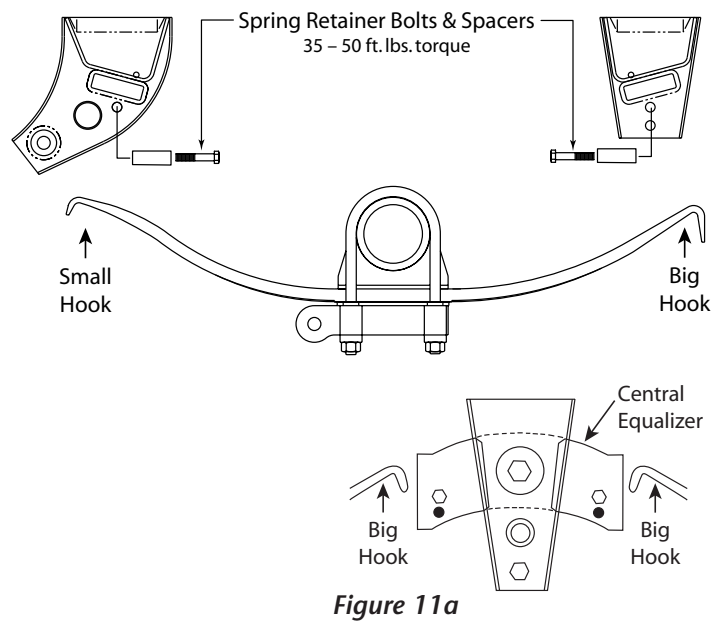

Figure 12

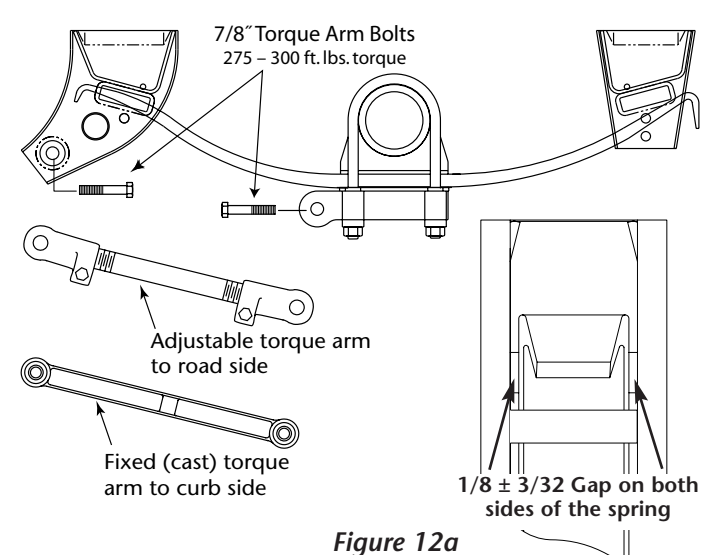

Figure 12a

AXLE ALIGNMENT INSTRUCTIONS

After suspension installation, and periodically thereafter, the axles should be aligned to insure proper tracking of the trailer and to avoid excessive tire wear. For best results, the use of axle and kingpin extensions is recommended.

1. When aligning axles, the suspension should be in a natural relaxed state, free of any "binds." Before taking measurements, and to achieve this relaxed condition, make sure the vehicle is unloaded. Then roll it back and forth on a level floor. Avoid brake application (including the parking brake). Vehicle must be level from side-to-side, as well as from front-to-rear. The upper coupler should be at the ride height.
2. Maintain the air system at normal operating pressure (greater than 80 psi). **DO NOT** drain the air tank.
3. Check that the ends of the springs are contacting the bottom wear pads in all hangers.
4. Loosen the 5/8" clamp bolts on the adjustable torque arms.
5. Align the front axle with the kingpin by adjusting the front adjustable torque arm.
6. Align the rear axle with the front axle in the same manner.
7. Tighten the clamp bolts on the adjustable torque arm and track rod ends to 80 – 95 ft. lbs. of torque.

Figure 13 Axle Alignment

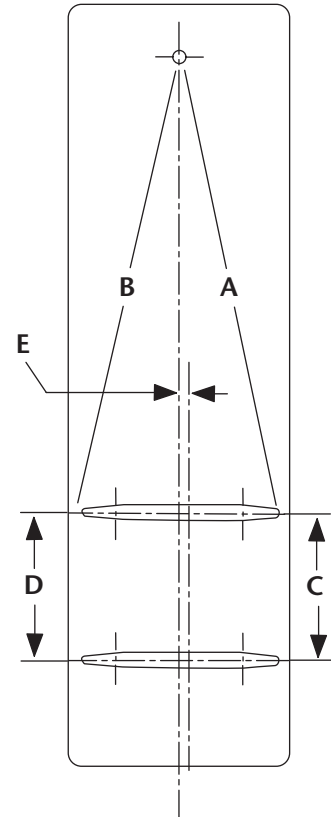

$$A = B \pm 1/8'' (3\text{mm})$$

$$C = D \pm 1/16'' (1.6\text{mm})$$

$$E = \leq 1/4'' (6\text{mm})$$

FINAL INSPECTION

1. Verify that the hanger brackets to mounting sub-frame and axle seat welds have been completed per specifications (Figures 5a, 5b and 5c).
2. Check all suspension fastener connections for proper torque settings (Figures 15 and 16).
3. Check adjustable torque arm clamp nuts to be certain that 85 – 95 ft. lbs. torque is maintained.
4. Check for proper suspension mounting height. Adjust with axle seat shims if necessary (Figure 14).
5. Check for proper 4½" vertical tire clearance (Figure 14). Check for lateral tire clearance.
6. Verify that the front axle alignment does not exceed a maximum variation of 1/8" kingpin to front axle and a maximum variation of 1/16" axle to axle on any additional axles (Figure 13).

Figure 14 (Overslung axle style shown)

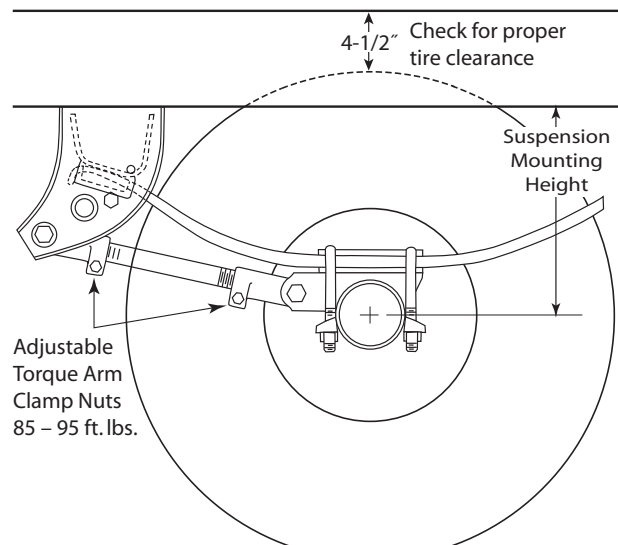

MAINTENANCE RECOMMENDATIONS

DuraLite® suspensions, by design, require a minimum of maintenance. However, suspensions in “over-the-road” operations require periodic checks to be certain of continued trouble free performance. We recommend, after an initial loaded run-in period of at least 1,000 miles, that you recheck the trailer alignment and correct if required. Routine visual inspections and appropriate maintenance of suspension is required every six months or 25,000 miles, whichever comes first. Furthermore, all fasteners, especially U-bolts, should be retorqued to the following specifications.

1. Check 3/4-16 U-bolt nuts to be certain that 275–300 ft. lbs. torque is maintained.
2. Check 1-14 equalizer bolt to be certain that 450–500 ft. lbs. torque is maintained
3. Check 7/8-14 torque arm bolts to be certain that 275–300 ft. lbs. torque is maintained.
4. Check adjustable torque arm clamp nuts to be certain that 85–95 ft. lbs. torque is maintained.
5. Check spring retainer hold down bolts to be certain that 35–50 ft. lbs. torque is maintained.

⚠ WARNING

Failure to maintain proper fastener torque values could result in suspension component damage and/or possible loss of vehicle control.

Figure 15 Overslung Axle Model

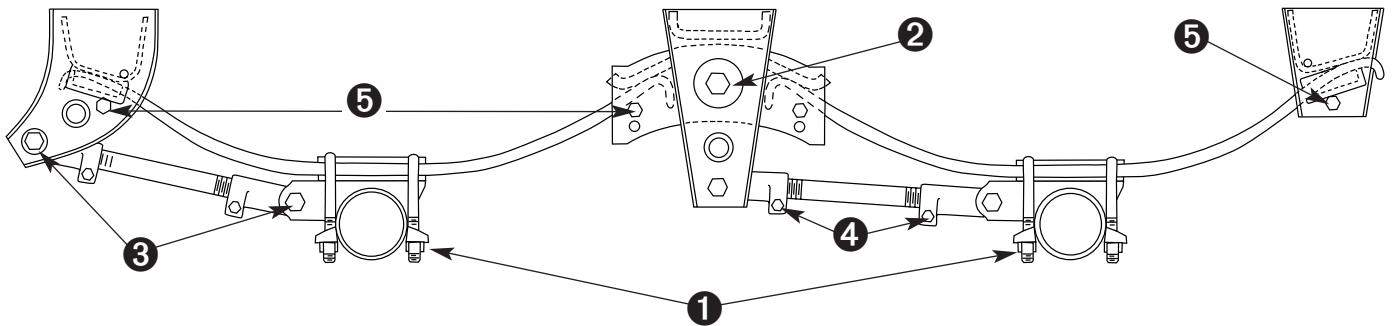
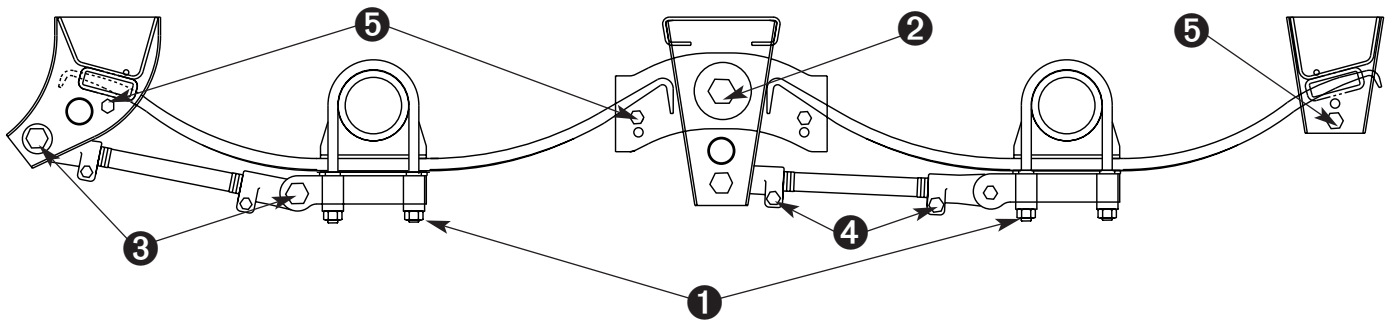

Figure 16 Underslung Axle Model



LEAF SPRING SELECTION

Holland DuraLite suspensions are rated at 22,400 pounds GAWR (Gross Axle Weight Rating) with one, two or three leaf springs, and 24,000 pounds GAWR with heavy-duty three leaf springs. (Holland does not supply springs.)

The following widely available leaf springs are suitable for use with DuraLite suspensions:

TABLE 1

SPRING TYPE	SINGLE LEAF	TWO LEAF	THREE LEAF	THREE LEAF HD
Low Arch	SP0363	SP0326	SP0356	SP9365-01
Medium Arch	–	SP0325	SP0355	–
High Arch	SP0360	SP0324	SP0354	SP0365

MOUNTING HEIGHT SPRING SEAT SELECTION

IMPORTANT: It is the installer's responsibility to select the correct mounting height. There should be 4½" of vertical tire clearance with an unloaded vehicle. In addition, clearance must be provided at the side front and rear of the tires to prevent tire contact during suspension movement. The mounting heights, shown below, are nominal values and may vary due to variations in the leaf springs and other components.

CONVENTIONAL (OVERSLUNG) MOUNTING HEIGHT

TABLE 2

		SPRING SEAT AND U-BOLT KIT						
SPRING SEAT HEIGHT		3/4" SPK0031	1-1/4" SPK0032	1-3/4" SPK0033	2-1/4" SPK0034	2-3/4" SPK0035	3-1/4" SPK0036	3-3/4" SPK0037
SPRING TYPE	Low Arch	13-3/4"	14-1/4"	14-3/4"	15-1/4"	15-3/4"	16-1/4"	16-3/4"
	Medium Arch	14-1/2"	15"	15-1/2"	16"	16-1/2"	17"	17-1/2"
	High Arch	16"	16-1/2"	17"	17-1/2"	18"	18-1/2"	19"

IMPORTANT: Mounting heights should not exceed 17-1/2" for best performance. Mounting height should provide a minimum of 4-1/2" of tire clearance with an empty vehicle. Table 2 applies to under mount or flange mount hangers on a multi-axle suspension. For single axle suspensions, subtract 1/2" from the above heights. For straddle mount hangers, subtract 1/2".

UNDERSLUNG MOUNTING HEIGHT

TABLE 3

		UNDER SLUNG MOUNTING HEIGHT			
SPRING SEAT HEIGHT		1/4" SPK0045	1-1/4" SPK0046	1-3/4" SPK0047	2-1/4" SPK0048
SPRING TYPE	Low Arch	4-1/2"	–	–	–
	Medium Arch	5-1/2"	5"	4-1/2"	–
	High Arch	7"	6-1/2"	6"	5-1/2"

IMPORTANT: Mounting heights less than 4-1/2" are not suggested due to lack of clearance between the axle and trailer frame. Mounting height should provide a minimum of 4-1/2" of tire clearance with an empty vehicle. Sufficient clearance should be provided for axle movement. Table 3 applies to under mount or flange mount hangers with a multi-axle suspension. For single axle suspensions, subtract 1/2" from the above heights. For straddle mount hangers, subtract 1/2" from the above heights.



HOLLAND USA, INC.
 1950 Industrial Blvd. • P.O. Box 425
 Muskegon, MI 49443-0425
 Phone 888-396-6501 • Fax 800-356-3929
 www.thehollandgroupinc.com

GO THE DISTANCE.

Copyright © October 2004 • The Holland Group, Inc.

Holland USA, Inc. Facilities:
 Dumas, AR Warrenton, MO
 Holland, MI Wylie, TX
 Muskegon, MI
 Ph: 888-396-6501 Fax: 800-356-3929

Holland International, Inc.
 Holland, MI
 Phone: 616-396-6501
 Fax: 616-396-1511

Holland Hitch of Canada, Ltd.
 Woodstock, Ontario • Canada
 Phone: 519-537-3494
 Fax: 800-565-7753

Holland Equipment, Ltd.
 Norwich, Ontario • Canada
 Phone: 519-863-3414
 Fax: 519-863-2398

Holland Hitch Western, Ltd.
 Surrey, British Columbia • Canada
 Phone: 604-574-7491
 Fax: 604-574-0244

Installation and Operation Manual

CBX/CB Series

Fixed Frame Top Mount Trailer Air Suspension

- For Disc and Drum Brake Applications

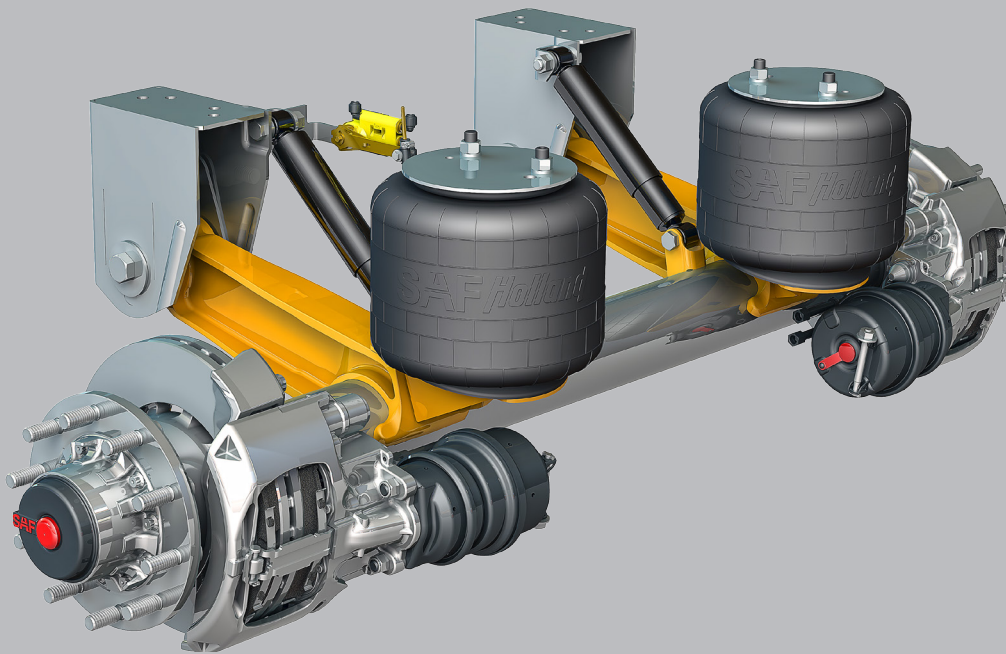

Contents	Page
Introduction.....	3
Warranty.....	3
Notes, Cautions, and Warnings	3
Section 1 – General Safety Instructions	4
Section 2 – Standard Decal Requirements	5
Section 3 – CBX Fusion Model Identification	6
Section 4 – CBX Fusion Model Nomenclature	6
Section 5 – CBX Model Identification	7
Section 6 – CBX Model Nomenclature	7
Section 7 – CB-2300 Model Identification	8

Contents	Page
Section 8 – CB-2300 Model Nomenclature	8
Section 9 – Welding Standards	9
Section 10 – Standard Air Control System Installation	10
Section 11 – Suspension Assembly Installation	11
Section 12 – Ride Height Adjustment	12
Section 13 – SwingAlign™ Axle Alignment.....	14
Section 14 – Brake Adjustment Instructions.....	14
Section 15 – Pre-Operation Information	15
Section 16 – Maintenance and Service Schedule.....	16
Section 17 – Torque Specifications	17

Introduction

This manual provides information necessary for the installation and operation of the SAF-HOLLAND® CBX/CB fixed frame top mount trailer air suspension. Although the images throughout this manual depict the CBX23 Fusion, there is no difference in fit or function between the models in the CBX/CB Series.

The CBX/CB suspensions include premium 5.75" diameter axles, the CB suspensions include 5" diameter axles. For axle end and/or brake servicing information or component replacements, refer to Drum Brake Manual XL-TA100060M-en-US, Disc Brake Manual XL-SA100590M-en-US or contact Customer Service at 888-396-6501.

This suspension uses air drawn from the tractor air system to pressurize the air springs. The height control valve (HCV) regulates the air pressure required for varying loads while maintaining the design ride height. This suspension can provide a cushioned ride throughout the load range, from empty to fully loaded.

The suspension also provides excellent side-to-side and axle-to-axle loading which helps equalize and control braking.

Read this manual before using or servicing this product and keep it in a safe location for future reference. Updates to this manual, which are published as necessary, are available on the internet at www.safholland.us.

When replacement parts are required, SAF-HOLLAND highly recommends the use of only SAF-HOLLAND Original Parts. A list of technical support locations that supply SAF-HOLLAND Original Parts and an Aftermarket Parts Catalog are available on the internet at www.safholland.us or contact Customer Service at 888-396-6501.

Warranty

Refer to the complete warranty for the country in which the product will be used. A copy of the written warranty is included with the product or available on the internet at www.safholland.com.

Notes, Cautions, and Warnings

Before starting any work on the unit, read and understand all the safety procedures presented in this manual. This manual contains the terms "NOTE", "IMPORTANT", "CAUTION", and "WARNING" followed by important product information. These terms are defined as follows:

NOTE: Includes additional information to enable accurate and easy performance of procedures.

IMPORTANT: Includes additional information that if not followed could lead to hindered product performance.

CAUTION

Used without the safety alert symbol, indicates a potentially hazardous situation which, if not avoided, could result in property damage.

⚠ CAUTION

Indicates a potentially hazardous situation which, if not avoided, could result in minor or moderate injury.

⚠ WARNING

Indicates a potentially hazardous situation which, if not avoided, could result in death or serious injury.

1. Safety Instructions

General and Servicing Safety Instructions

- Read and observe all Warning and Caution hazard alert messages. The alerts provide information that can help prevent serious personal injury, damage to components, or both.

⚠️ WARNING Failure to follow the instructions and safety precautions in this manual could result in improper servicing or operation leading to component failure which, if not avoided, could result in death or serious injury.

- All maintenance should be performed by a properly trained technician using proper/special tools, and safe procedures.

NOTE: In the United States, workshop safety requirements are defined by federal and/or state Occupational Safety and Health Act (OSHA). Equivalent laws may exist in other countries. This manual is written based on the assumption that OSHA or other applicable employee safety regulations are followed by the location where work is performed.

- Properly support and secure the vehicle from unexpected movement when servicing the unit.

⚠️ WARNING Failure to properly support and secure the vehicle and axles prior to commencing work could create a crush hazard which, if not avoided, could result in death or serious injury.

- If possible, unload the trailer before performing any service procedures.
- After re-positioning the brake chamber, slack adjuster and/or ABS system as instructed in this manual, always consult the manufacturer’s manual for proper operation.
- Service both roadside and curbside of an axle. Worn parts should be replaced in sets. Key components on each axle’s braking system, such as friction material, rotors and drums will normally wear over time.
- Follow all manufacturer’s instructions on spring pressure and/or air pressure controls.

⚠️ WARNING Failure to follow manufacturer’s instructions regarding spring pressure or air pressure control could allow unexpected release of energy which, if not avoided, could result in death or serious injury.

- DO NOT paint the wheel contact surfaces between the wheel and hub.

IMPORTANT: The wheel contact surfaces MUST be clean, smooth and free from grease.

⚠️ WARNING Failure to keep wheel and hub contact surfaces clean and clear of foreign material could allow wheel/hub separations which, if not avoided, could result in death or serious injury.

- Only the wheel and tire sizes approved by the trailer builder can be used.

Operational and Road Safety Instructions

- Before operating vehicle, ensure that the maximum permissible axle load is NOT exceeded and that the load is distributed equally and uniformly.
- Make sure that the brakes are NOT overheated from continuous operation.

⚠️ WARNING Failure to minimize the use of brakes during overheating conditions could result in deterioration of brake efficiency which, if not avoided, could result in death or serious injury.

- The parking brake MUST NOT be immediately applied when the brakes are overheated.

CAUTION If the parking brake is immediately applied to the brakes when overheated, the brake drums or discs could be damaged by different stress fields during cooling.

- Observe the operating recommendation of the trailer manufacturer for off-road operation of the installed axles.

IMPORTANT: The definition of OFF-ROAD means driving on non-asphalt/non-concrete routes, e.g. gravel roads, agricultural and forestry tracks, on construction sites and in gravel pits.

IMPORTANT: Off-road operation of axles beyond the approved application design could result in damage and impair suspension system performance.

- Follow the recommended routine maintenance and inspections described in this manual. These procedures are designed so that optimum performance and operational safety are achieved.
- In the event of suspension air pressure loss, quickly reduce speed as safely as possible and remove the vehicle from traffic. If unable to remove vehicle from traffic, follow DOT safety requirements regarding emergency situations.
- Contact a qualified towing and/or service company to assist in repairing the vehicle or to move it to a qualified repair facility. DO NOT operate the vehicle in the absence of suspension air pressure; however in the event of an air system failure while in service, an internal rubber bumper built into the air spring will make it possible to temporarily operate the vehicle at reduced speed determined by road conditions.

⚠️ WARNING Operating the vehicle without proper air pressure can cause tire failure, fire, or loss of vehicle control which, if not avoided, could result in death or serious injury.

2. Standard Decal Requirements

The following three (3) decals MUST be properly installed on the trailer prior to putting it in service:

- Tire Clearance Warning Decal: XL-AR356-01 (**Figure 1**).
- SwingAlign Axle Alignment Decal: XL-AR435 (**Figure 2**).
- Torque Decal: XL-AR436 (**Figure 3**).
- Shear Bolt Decal: XL-AS20085DC-en-US (**Figure 4**).

It is the responsibility of the end user to periodically inspect all decals and ensure that they are clean and completely legible. If any decals are missing, loose, damaged or difficult to read, contact SAF-HOLLAND Customer Service at 888-396-6501 to order replacements immediately.

Figure 1

⚠ WARNING

Minimum tire clearance MUST be maintained between tires and nearest point of contact on the suspension or vehicle. Premature tire wear, fire or loss of vehicle control could result from contact with the tires if clearances are not maintained.

SAF Holland
Copyright © 2011 • SAF-HOLLAND, Inc. www.safholland.us **XL-AR356-01**

TIRE CLEARANCE REQUIREMENTS

- **1 INCH (25.4 mm) MINIMUM VERTICAL** tire clearance is required between the top of the tire and the nearest point of contact above the tire when the air pressure is completely exhausted from the air suspension or when the axle is fully lifted if equipped with a suspension lift feature.
- **2 INCH (50.8 mm) MINIMUM LATERAL** tire clearance is required between the sides of the tire and the nearest point of contact through total travel of the air suspension. This includes when the wheels are fully turned in either direction if equipped with an SAF Self Steer Axle.

Figure 2

SWING ALIGN® NON-WELDED AXLE ALIGNMENT PROCEDURES

ALIGNMENT BOLT IS ON THE FRONT OF THE ROADSIDE FRAME BRACKET:

STEP 1. To properly align the suspension, the trailer should be pulled in a straight line for a sufficient distance to insure there are no binds in the suspension.

STEP 2. Check to verify trailer is empty and emergency brakes are **NOT** engaged.

STEP 3. Rotate bolt **CLOCKWISE** to move axle forward (A arrows); **COUNTERCLOCKWISE** to move axle rearward (B arrows).

SAF Holland
Copyright © 2011 • SAF-HOLLAND, Inc. www.safholland.us **XL-AR435**

ALIGNMENT BOLT HEAD

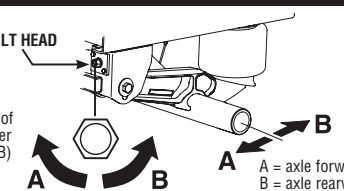

NOTE: 1/2 turn of free play in either direction (A or B) is acceptable.

A = axle forward
B = axle rearward

Figure 3

CBX / CB FIXED FRAME TRAILER AIR SUSPENSION TORQUE SPECIFICATIONS

Torques are with clean, lubricated threads.
Always apply torque to nut, if possible.

REQUIRED RE-TORQUING SCHEDULE:

- All fasteners after first three (3) months or 5,000 miles.
- At every routine preventative maintenance.
- At every brake relining.

Fastener Size	Pivot Connection	Shock	Air Spring		SwingAlign
	1-1/8"	3/4"	1/2"	3/4"	1/2"
Torque ft.-lbs. (N•m)	550-600 (746-813)	140-175 (190-237)	30-40 (41-54)	40-45 (54-61)	50-60 (68-81)

SAF Holland
Copyright © 2014 • SAF-HOLLAND®, Inc. www.safholland.us **XL-AR436**

Figure 4

SHEAR BOLT – FRONT PIVOT CONNECTION

This suspension has been installed with a shear bolt front pivot connection design. This connection requires no torque check, but does **REQUIRE VISUAL INSPECTION**. Inspect that the spline has been sheared off and for any signs of movement:

- Prior to placing trailer in service.
- After three (3) months or 5,000 miles.
- At every routine preventative maintenance.
- At every brake relining.

CAUTION DO NOT apply anti-sieze compound or additional lubricant to pivot connection hardware. This can lead to unpredictable clamp loads and unreliable axle alignment.

XL-AS20085DC-en-US

SHEAR BOLT STYLES



E-20 HEAD SPLINE (AFTERMARKET)

SPLINE TO SHEAR OFF ONCE PROPER CLAMP LOAD IS ACHIEVED

TENSION CONTROL (OEM)

www.safholland.us
Copyright © 2018 • SAF-HOLLAND®, Inc. **SAF Holland**

3. CBX Fusion Model Identification

The CBX Fusion suspension serial tag is located on the frame bracket (**Figure 4**).

NOTE: This manual applies to the suspension models listed on the front cover. However, determine the specific model number, write that information below and refer to it when obtaining information or replacement parts (**Figure 5**).

NOTE: If the suspension serial tag is NOT legible or is NOT available, it can be identified by the appearance of the equalizing beam (**Figure 6**). The CBX Fusion model will have a cast beam with a lower air spring mounting plate welded to it mounted on a 5.75" round axle (**Figure 6**).

NOTE: The CBX Fusion models come in four (4) different beam lengths. Equalizing beam lengths are measured from the centerline of the pivot to the centerline of the air spring mounting plate (**Figure 6**).

Figure 4

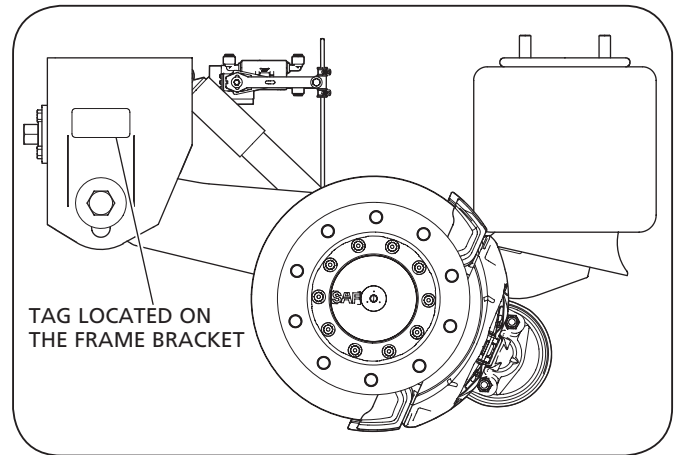
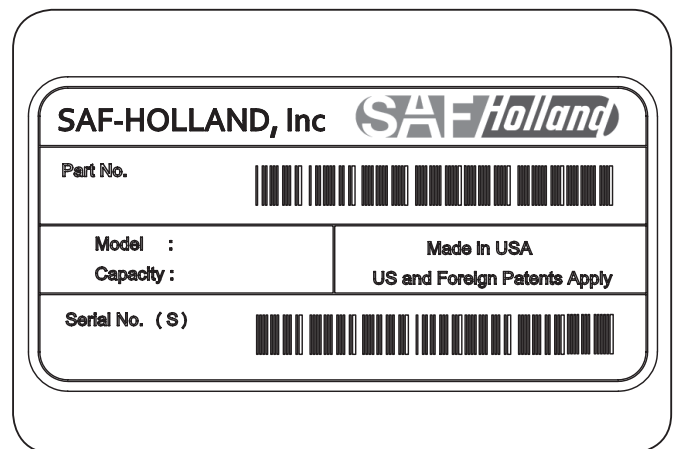

Figure 5



4. CBX Fusion Model Nomenclature

The sample tag illustrated will help interpret the information on the SAF-HOLLAND, Inc. serial number tag. The part number is on the first line. The model number along with the suspension capacity are on the second line. The third line contains the serial number (**Figure 5**).

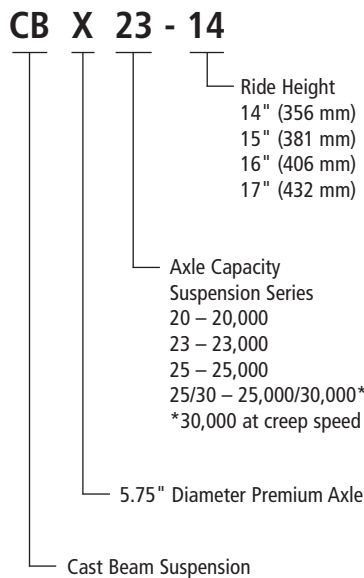
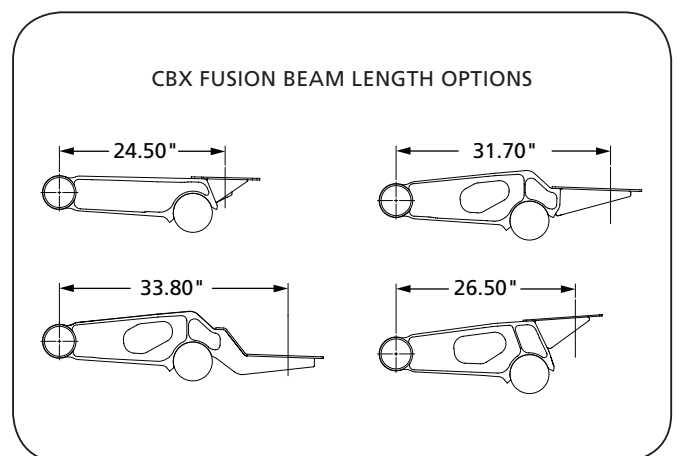

Figure 6



5. CBX Model Identification

The CBX suspension serial tag is located on the frame bracket (**Figure 7**).

NOTE: This manual applies to the suspension models listed on the front cover. However, we urge you to determine your specific model number, write that information below and refer to it when obtaining information or replacement parts (**Figure 8**).

NOTE: If the suspension serial tag is NOT legible or is NOT available, it can be identified by the appearance of the equalizing beam. The CBX model will have a full cast beam mounted to a 5.75" round axle (**Figure 9**).

NOTE: The CBX models come in three (3) different beam lengths. Equalizing beam lengths are measured from the centerline of the pivot to the centerline of the air spring mounting plate (**Figure 9**).

6. CBX Model Nomenclature

The sample tag illustrated will help interpret the information on the SAF-HOLLAND, Inc. serial number tag. The model number is on the first line along with the suspension capacity. The second line contains the part number and the serial number (**Figure 8**).

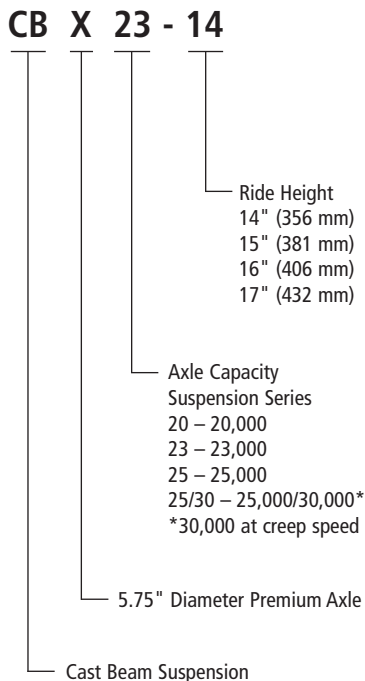

Figure 7

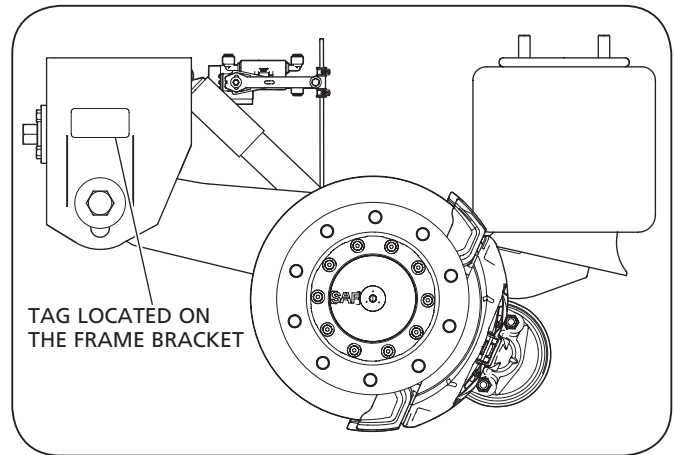

Figure 8

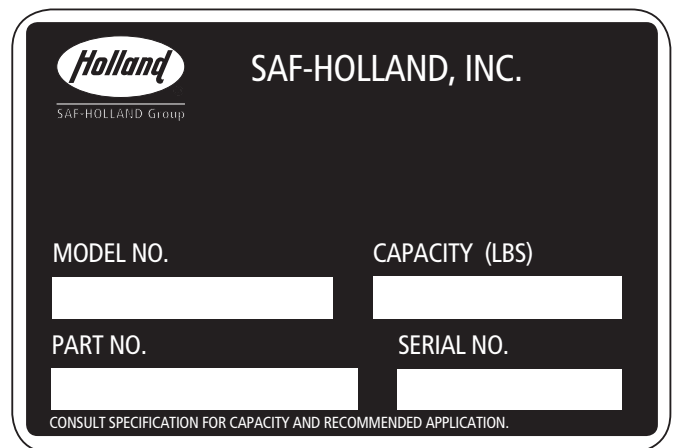
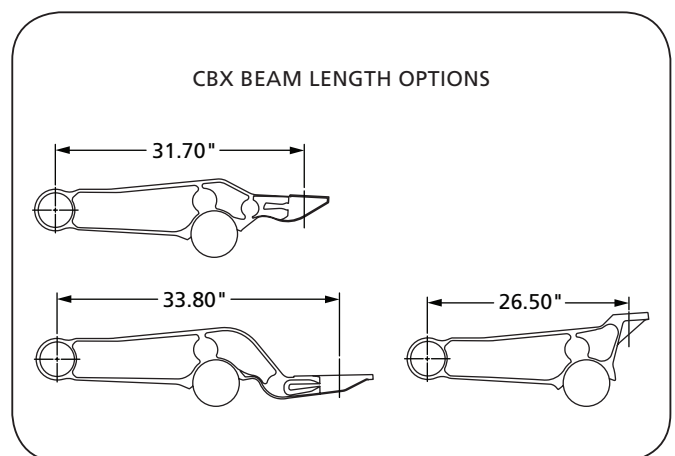

Figure 9



7. CB-2300 Model Identification

The CB-2300 suspension serial tag is located on the frame bracket (**Figure 10**).

NOTE: If the suspension serial tag is NOT legible or is NOT available, you can identify your suspension model by the appearance of the equalizing beam. The CB-2300 model will have a full cast beam with a 5" round axle (**Figure 10**).

NOTE: This manual applies to the suspension models listed on the front cover. However, determine the specific model number, write that information below and refer to it when obtaining information or replacement parts (**Figure 11**).

Figure 10

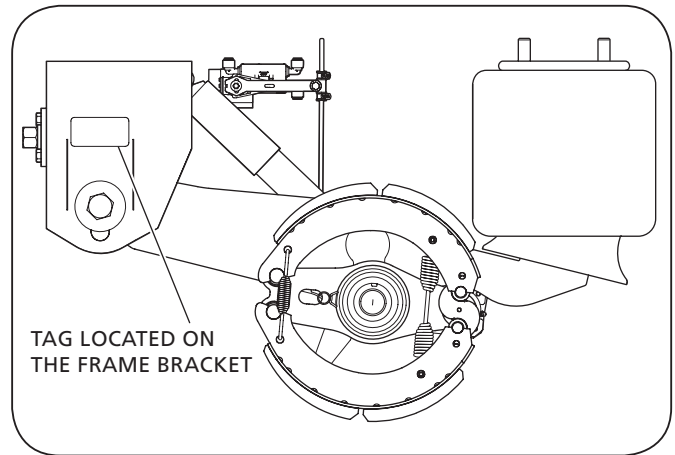

8. CB-2300 Model Nomenclature

The sample tag illustrated will help interpret the information on the SAF-HOLLAND, Inc. serial number tag. The model number is on the first line along with the suspension capacity. The second line contains the part number and the serial number (**Figure 11**).

Figure 11

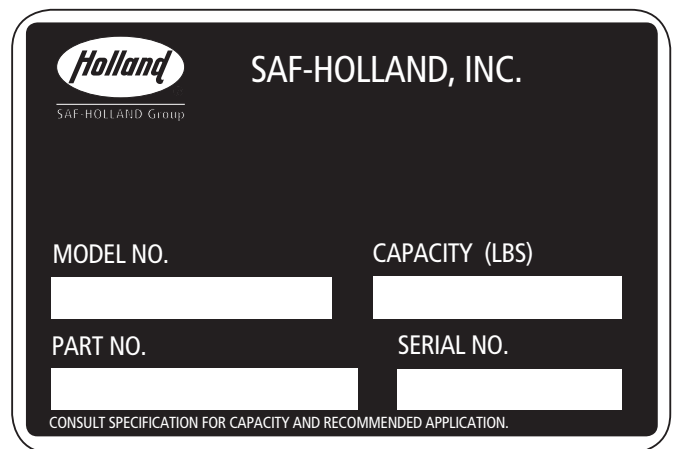

CB 2300 - 14

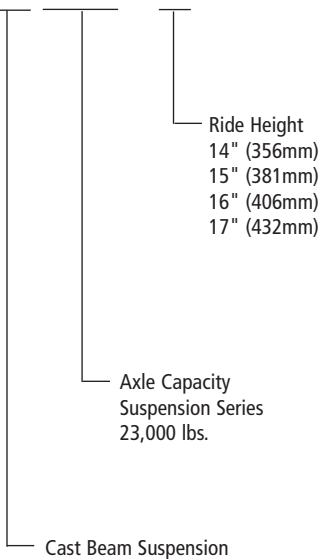

9. Welding Standards

9.1 Scope

When welding is required for the suspension repairs, observe the requirements below. This specification applies to all components supplied by SAF-HOLLAND, and its products. The customer assumes all responsibility for weld integrity if weld material and procedure differ from those listed below.

9.2 Workmanship

All welding on SAF-HOLLAND products MUST be performed by a welder qualified according to the appropriate AWS standard for the weld being made or an equivalent standard. It is the responsibility of the customer to provide good workmanship when welding on SAF-HOLLAND products.

9.3 Material

Items to be welded that are made from low carbon or high-strength alloy steel are to be welded with AWS filler metal specification AWS A5.18, filler metal classification ER-70S-3, ER-70S-6 or equivalent unless specified on the installation drawing.

NOTE: Any substitution for filler material from the above standard must comply, as a minimum, with the following mechanical properties:

Tensile Strength - 72k psi (496 MPa)
Yield Strength - 60k psi (414 MPa)
Charpy V Notch - 20 ft.-lbs. (27 N•m) at 0°F (-17.7°C)
% Elongation - 22%

The recommended welding gas for gas metal arc welding (GMAW) is 90% Argon / 10% CO₂. If a different gas is used, welds must comply with penetration requirements illustrated (**Figure 12**). Where the installation drawing specifies different than above, the drawing shall prevail.

9.4 Procedures

Tack welds used for positioning components are to be located in the center of the final weld, where practical. Tack weld should be completely fused to the finish weld. DO NOT break arc at the end of the weld. Back up all finish welds at least 1/2" (12.7 mm) or a sufficient amount to prevent craters at the end of the weld. Where weld is illustrated to go around corners, it is assumed the corner represents a stress concentration area. DO NOT start or stop weld within 1" (25.4 mm) of the corner. Particular care should be taken to prevent undercutting in this area.

9.5 Weld Size

If weld size is NOT specified, the effective throat of the weld MUST be no smaller than the thinnest material being welded (**Figure 12**).

Figure 12

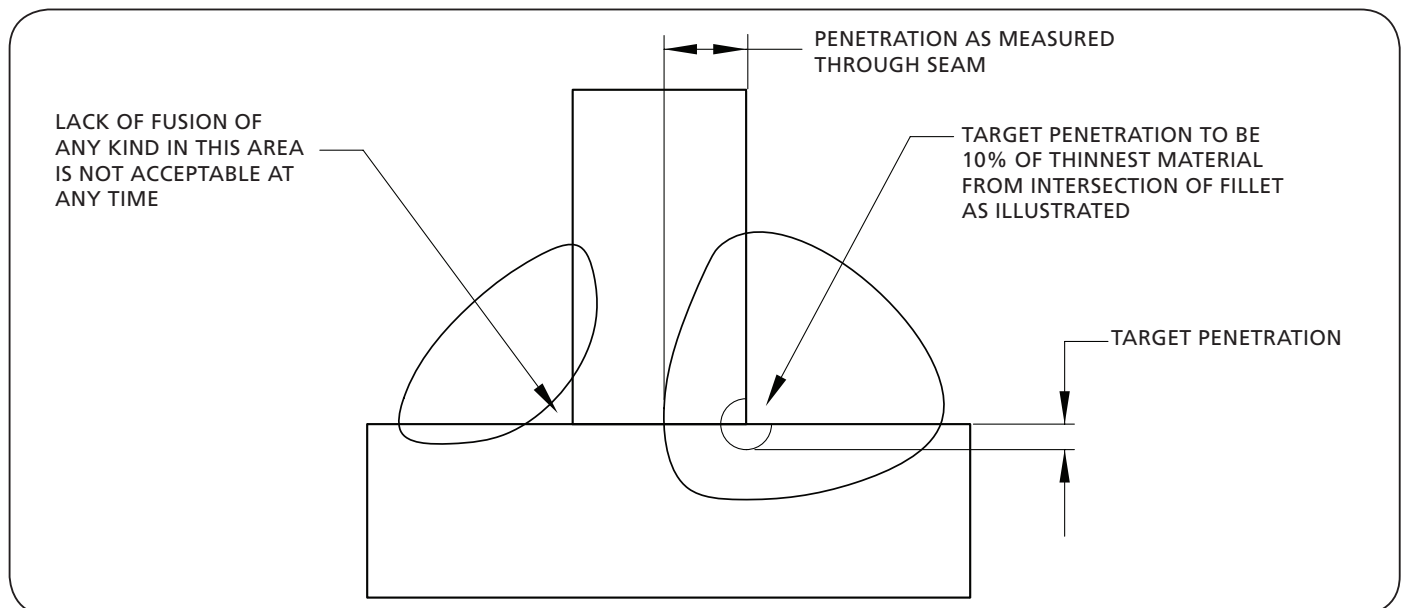

10. Standard Air Control System Installation

The following is a typical air system installation and should be plumbed as illustrated (**Figure 13**). Optional air control systems are available. Contact SAF-HOLLAND applications department to discuss your particular needs.

The air control system of the CBX/CB suspensions use air drawn from the tractor air system to pressurize the suspension's air springs. The suspension, working with the air control system, provides optimum suspension performance only when all air control system components are installed and operating properly.

IMPORTANT: Make certain that all air lines and valves are free from obstruction through the full operational range of the suspension.

IMPORTANT: A pressure protection valve (PPV) **MUST** be attached to the air reservoir in order to maintain proper air pressure (**Figure 13**).

IMPORTANT: The air pressure protection valve maintains safe brake pressure. Approximately 85 psig (5.9 bars) opens the valve, and 65 psig (4.5 bars) closes the valve.

NOTE: When installing the pressure protection valve, use a drop of oil or Loctite® to lubricate threaded connections. **DO NOT** use a pipe compound or teflon tape as they may clog the valve.

A height control valve (HCV) is used to regulate the air pressure required for varying load capacities (**Figure 13**).

Figure 13

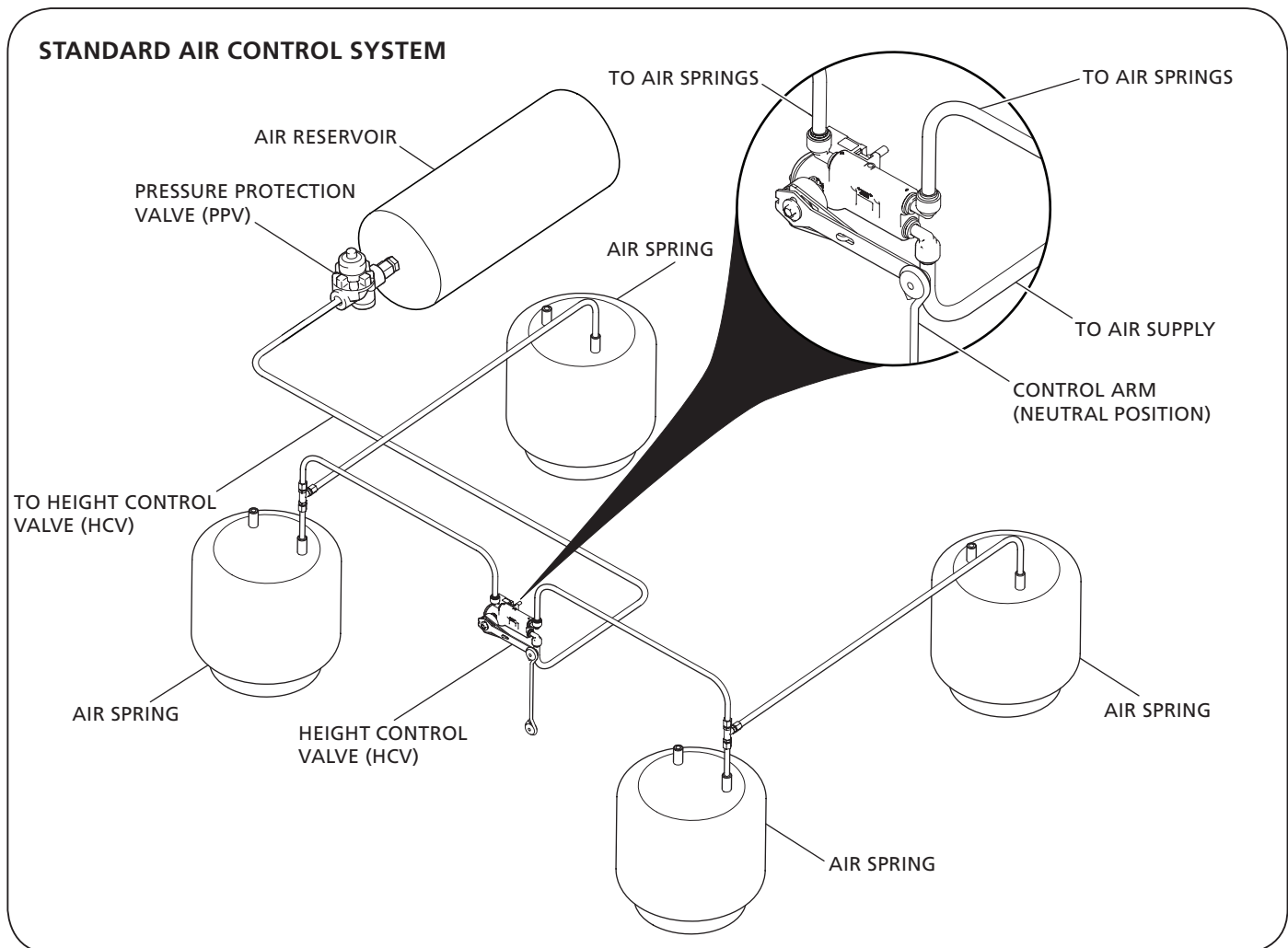

11. Suspension Assembly Installation

NOTE: Locate the suspension on the trailer frame. Refer to your model's specific installation drawing for the proper weld patterns and locations. To obtain a copy of your specific installation drawing, contact SAF-HOLLAND Customer Service at 888-396-6501.

1. Once the suspension is correctly positioned, weld the suspension in place as outlined in Section 9.
2. Ensure the linkage assembled to the height control valve (HCV) and suspension is installed properly (**Figure 14**).
3. Install the service and emergency lines to the suspension and allow the suspension to air up.
6. Measure the ride height of the suspension with a tape measure (**Figure 15**).
7. Compare the measured suspension ride height value to the appropriate value (**Table 1**). Ensure the measured ride height value is within $\pm 1/4"$ (6 mm).

IMPORTANT: If the measured ride height value is NOT within $\pm 1/4"$ (6 mm), follow the Ride Height Adjustment procedures described in Section 12.

4. Visually check all air control system fittings for air leaks by applying a soapy water solution and checking for bubbles at all air connections and fittings.

Figure 14

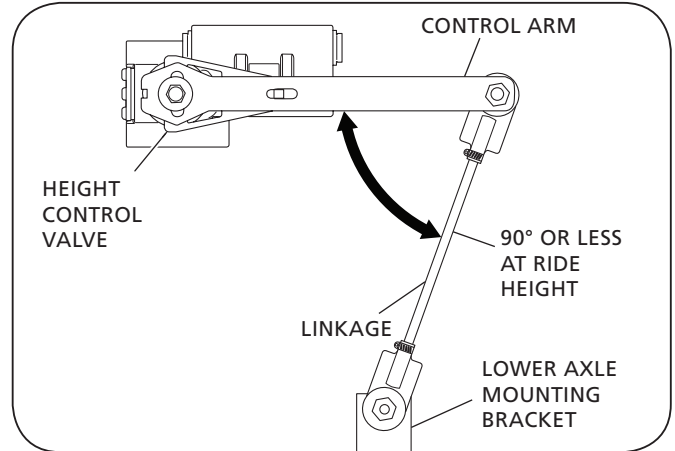
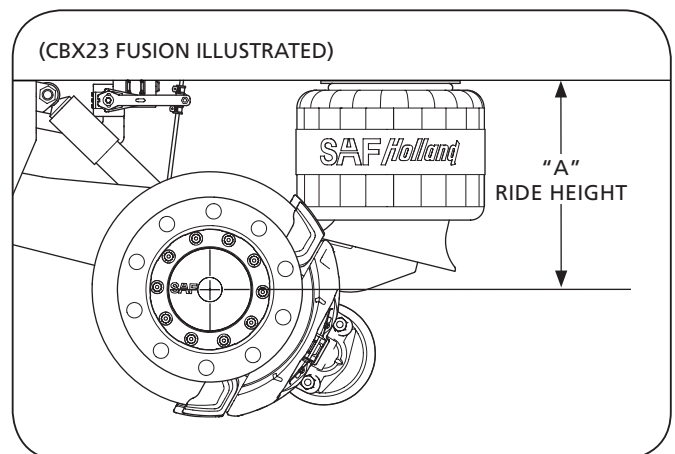

Table 1

MODEL	"A" RIDE HEIGHT
CBX/CB-14	14"
CBX/CB-15	15"
CBX/CB-16	16"
CBX/CB-17	17"

Figure 15



12. Ride Height Adjustment

IMPORTANT: Trailer MUST be unloaded before beginning any service procedures.

1. On a level surface, support the front of the trailer with either a kingpin stand, landing gear, or while coupled to a tractor (**Figure 16**).
2. Raise the trailer frame approximately 2" (51 mm) above the suspension's specified ride height (**Figure 17**).
3. Place multiple jack stands at the suspension's specified ride height (**Table 2**) under the vehicle frame at OEM specified locations, then lower the trailer onto the jack stands.

NOTE: It could be necessary to shim the jack stands to achieve specified ride height.

⚠ WARNING Failure to properly support the suspension during maintenance could create a crush hazard which, if not avoided, could result in death or serious injury.

Table 2

MODEL	"A" RIDE HEIGHT
CBX/CB-14	14"
CBX/CB-15	15"
CBX/CB-16	16"
CBX/CB-17	17"

4. Exhaust all air from the suspension, set the parking brakes, and chock the wheels.

⚠ WARNING Failure to exhaust the suspension air and chock the tires prior to beginning maintenance could allow vehicle movement which, if not avoided, could result in death or serious injury.

5. Disconnect the linkage from the control arm and lower the axle mounting bracket (**Figure 18**).
6. Pin the height control valve so that the valve arm is in the center or neutral position (**Figure 18**).

Figure 16

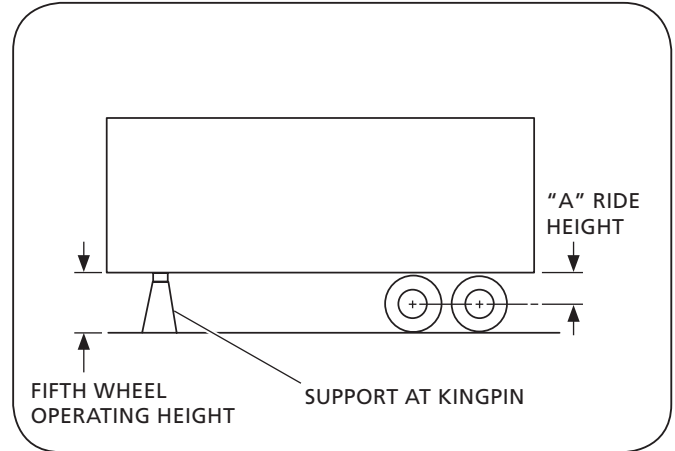

Figure 17

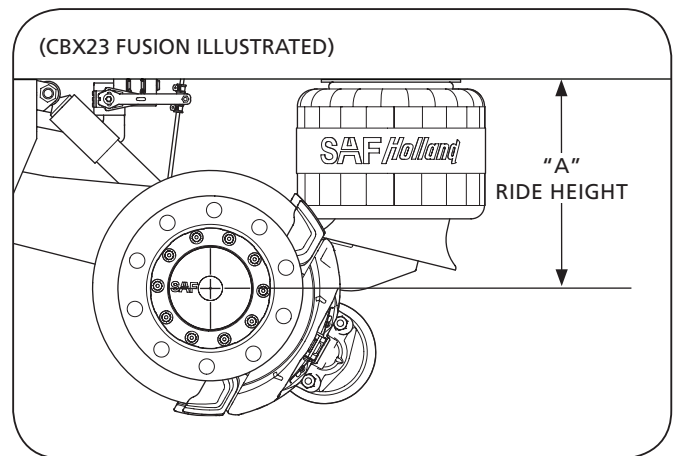
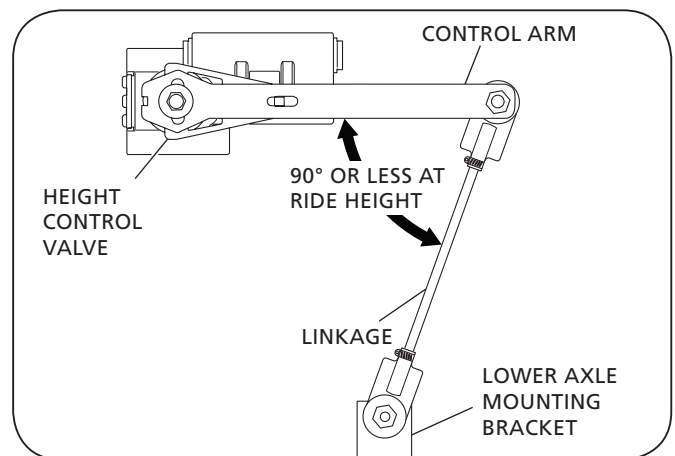

Figure 18



7. Measure distance "B" between the valve arm and mounting bracket holes to determine linkage length (**Figure 19**).
8. Adjust the linkage to required length and install the hardware into the upper and lower connections (**Figure 19**). Torque hardware to 30-40 in.-lbs. (3-5 N•m).

NOTE: It could be necessary to cut linkage rod to achieve proper length. Be sure to de-burr rod to prevent link end damage.

9. Raise the trailer approximately 2" (50 mm) above the ride height and remove the jack stands.
10. Slowly lower the trailer so that the trailer suspension is fully collapsed.
11. Pull the pin and apply air to the trailer allowing the suspension to return to ride height.
12. With the suspension at rest, measure the ride height. Ride height **MUST** be within 1/4" (6 mm) of the suspensions specified ride height.
13. Spray a soapy water mix on all air line connections to check for air leaks and verify fittings are tight.

IMPORTANT: It is the responsibility of the air system installer to secure all air lines and check for air leaks. If air leaks are detected, repair as required.

CAUTION

Failure to eliminate air leaks could compromise the suspension performance which, if not avoided, could result in component or property damage.

14. Remove the wheel chocks.

Figure 19

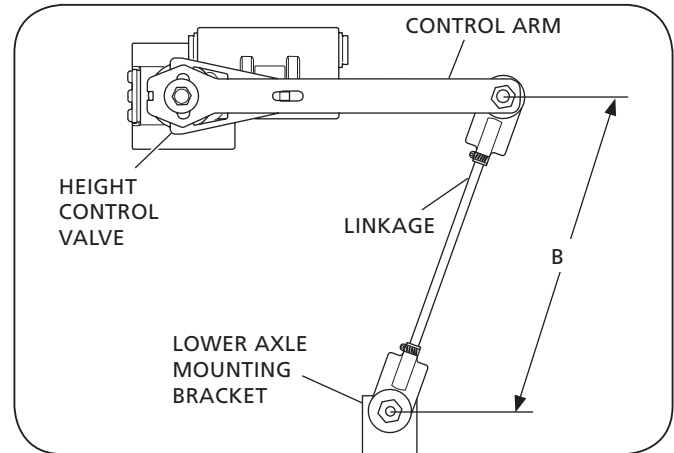

13. SwingAlign Axle Alignment

13.1 Alignment Preparation

1. Pull the trailer in a straight line for a sufficient distance to ensure that there are no binds in the suspension.
2. Disengage the trailer parking brakes and make sure the trailer is empty.
3. Manually measure or use an optical device specifically designed for alignment measuring to determine the following:
 - a. Measure the distance from the king pin to the centerline of the front axle spindles. It is recommended that the spindle extensions be utilized.
 - b. Dimensions A and B (**Figure 20**) MUST be equal to within 1/8" (3 mm).
 - c. Measure the distance from the centerline of the front axle spindles to the centerline of the rear axle spindles.
 - d. Dimensions C and D (**Figure 20**) MUST be equal to within 1/16" (1 mm).

Figure 20

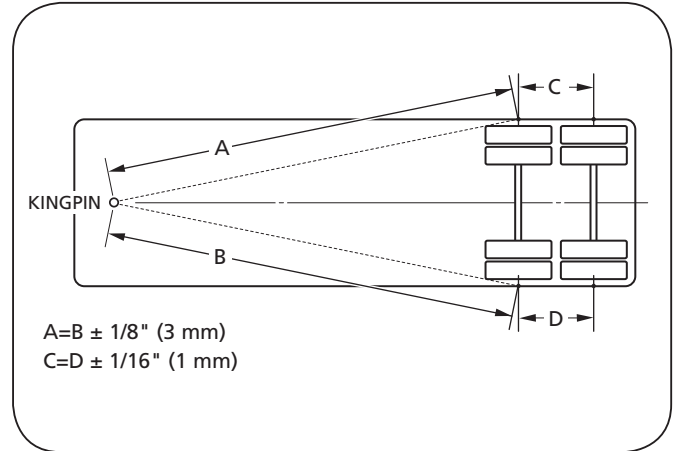

13.2 Alignment Instructions

1. Using the measurements per Section 13.1 Step 3, align each axle. Align by rotating the alignment bolt head using a 1-3/8" socket wrench on the front face of the road-side frame bracket clockwise to move axle forward (**A arrows**); counterclockwise to move axle rearward (**B arrows**) (**Figure 21**). Approximately 250 ft.-lbs. (339 N•m) will be required.

Figure 21

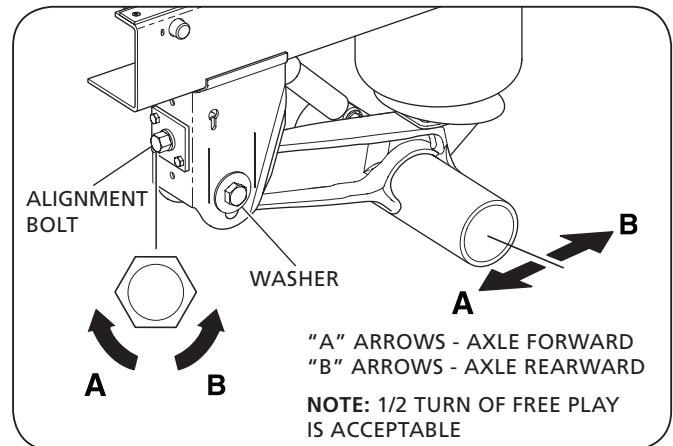

IMPORTANT: DO NOT loosen the pivot bolts.

IMPORTANT: Two (2) scribe lines on the side of the frame bracket indicate maximum adjustment for axle alignment. If the edge of the visible washer touches either scribe line, the SwingAlign axle alignment adjustment is "out of stroke." Inspect and repair trailer components as necessary and realign (**Figure 22**).

IMPORTANT: The SwingAlign design maintains proper alignment without welding or without loosening of the pivot connection. DO NOT weld alignment bolt or pivot bolts (**Figure 22**).

14. Brake Adjustment Instructions

Brakes should be adjusted per axle and brake manufacturer's specifications.

For CBX/CB Suspensions with Drum Brake Systems refer to SAF-HOLLAND Drum Brake Service Manual, XL-TA100060M.

For CBX Suspension with Disc Brake Systems refer to SAF-HOLLAND Disc Brake Service Manual, XL-SA100590M.

Figure 22

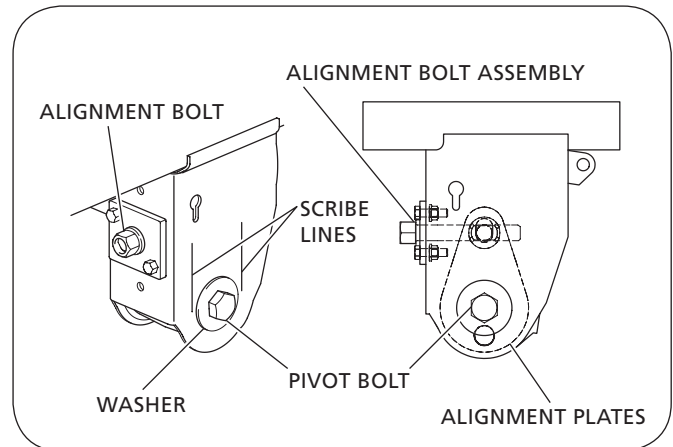

15. Pre-Operation

NOTE: In the United States, workshop safety requirements are defined by federal and/or state Occupational Safety and Health Act. Equivalent laws may exist in other countries. This manual is written based on the assumption that OSHA or other applicable employee safety regulations are followed by the location where work is performed.

1. With the vehicle on a level surface, bring air system to operating pressure (above 85 psig/5.9 bars).
2. Shut off the vehicle and visually check all air control system fittings for air leaks by applying a soapy water solution and checking for bubbles at all air connections and fittings. Examine the air springs (**Figure 23**) for equal firmness.
3. Check the shock absorbers for proper installation and make sure that the upper and lower 3/4" shock absorber nuts are torqued to 140-175 ft.-lbs. (190-237 N•m) (**Figure 23**).
4. Verify that the 1/2" air spring mounting nuts are torqued to 30-40 ft.-lbs. (41-54 N•m), and the 3/4" air spring mounting nuts are torqued to 40-45 ft.-lbs. (54-61 N•m) (**Figure 23**).

5. With the suspension at full capacity, check that there is a 1" (25 mm) minimum clearance around the air springs.
6. The suspension's ride height should be within $\pm 1/4$ " (6 mm) of the recommended design height. For proper ride height, refer to Section 12.
7. Determine which pivot bolt style is installed (**Figure 23**).
 - If 1-1/8" hex head bolt, verify torque on the nut is 550-600 ft.-lbs. (746-813 N•m).
 - If 7/8" pan head shear bolt, verify spline has been sheared off.

IMPORTANT: The SwingAlign design maintains proper alignment under correct torque without welding; DO NOT weld.

NOTE: SwingAlign pivot connections are on roadside and fixed alignment pivot connections are on curbside. For SwingAlign Connection Axle Alignment procedure, refer to Section 13.

Figure 23

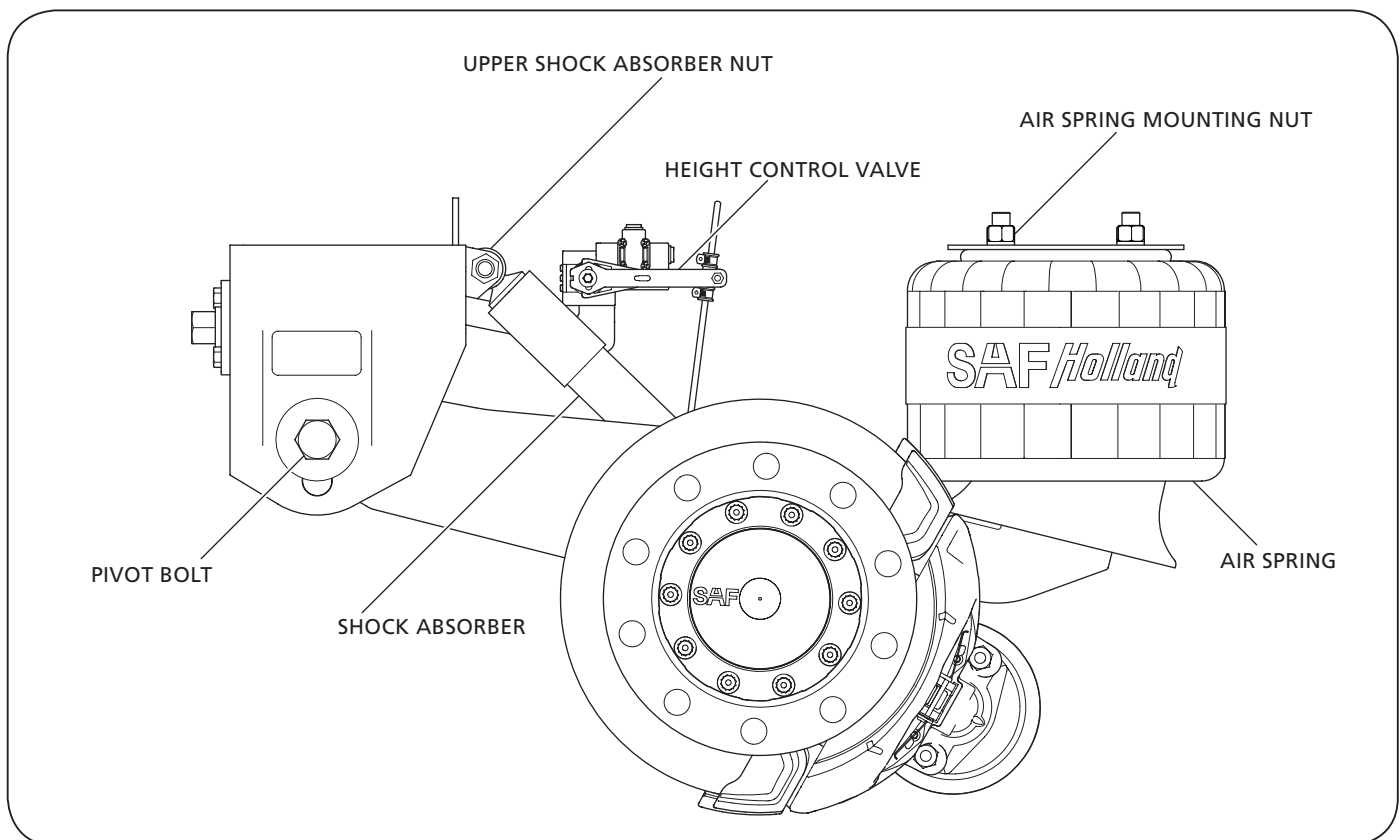

16. Routine Maintenance and Daily Inspection

1. Daily or before each trip, check the suspension to ensure it is fully operational.
2. Inspect all decals to ensure they are clearly legible and intact. Clean with a terry cloth towel, soap and water.
3. Visually inspect air springs for sufficient inflation and that the suspension is at proper ride height. For ride height details and measurements, refer to Section 12 of this manual.

16.1 Initial Three (3) Months or 5,000 Mile (8,000 km) Service Inspection

1. Suspension ride height (underside of frame to centerline of axle) MUST be within $\pm 1/4$ " (6 mm) of recommended design height. For instructions on measuring ride height, refer to Section 11.

CAUTION

An improperly set ride height could result in suspension component damage and/or poor vehicle ride performance.

2. After first three (3) months or 5,000 miles (8,000 km) of service, whichever comes first, inspect bolts and nuts at the pivot connections to ensure there are no signs of movement. Check all other nuts and bolts for proper torque, refer to the specifications listed in Section 17. Re-torque as necessary thereafter.
3. With the vehicle on a level surface and air pressure above 85 psig (5.9 bars), verify that all the air springs are of sufficient and equal firmness.

NOTE: Check all air control system fittings for air leaks, by applying a soapy water solution and checking for bubbles at all air connections and fittings.

16.2 Routine Physical Inspections

Every 100,000 Miles (160,000 km) or one (1) year, whichever comes first.

Check all other suspension components for any sign of damage, looseness, torque loss, wear or cracks. Repair, tighten or replace damaged part(s) to prevent equipment breakdown.

16.3 Visual Inspection Procedure

IMPORTANT: A schedule for physical and visual inspections should be established by the operator based on severity of operation or damage to the vehicle could occur.

IMPORTANT: During each pretrip and safety inspection of the vehicle, a visual inspection of the suspension should be done or damage to the vehicle could occur.

Visually check for:

- Loose, broken or missing fasteners. Repair or replace as needed.

WARNING

Loose, damaged, or missing fasteners can cause loss of vehicle control which, if not avoided, could result in death or serious injury.

- Air springs – clearances, wear damage, and proper inflation.
- Shock absorbers – leaking or damaged.
- Cracked parts or welds.

17. Torque Specifications

Table 3

COMPONENT	TORQUE VALUE	FASTENER SIZE
Shock Absorber	140-175 ft.-lbs. 190-237 N•m	3/4"
Pivot Connection, Hex Head Bolt	550-600 ft.-lbs. 746-813 N•m	1-1/8"
*Pivot Connection, Pan Head Shear Bolt	Visual Inspection	7/8"
Lower Air Spring Nut	30-40 ft.-lbs. 40-54 N•m	1/2"
Upper Air Spring Nut	40-45 ft.-lbs. 54-61 N•m	3/4"
SwingAlign Mounting Fasteners Only - NOT Pivot Bolt	50-60 ft.-lbs. 68-81 N•m	1/2"
Height Control Valve Lower Linkage	30-40 In.-lbs. 3-5 N•m	1/4"

All torque specifications are $\pm 5\%$.

Torques specified are for clean, lubricated threads.

Always Apply torque to nut if possible.

Required re-torquing at every brake re-lining.

* If equipped with 7/8" pan head shear bolt, ensure that the spline is sheared off and that there are no signs of movement.

NOTE: Torque specifications listed above are with clean lubricated / coated threads (**Table 3**). All new SAF-HOLLAND fasteners come precoated from the factory. For bolt and lock nut grade markings refer to **Figure 24**.

IMPORTANT: The use of special lubricants with friction modifiers, such as Anti-Seize or Never-Seez®, without written approval from SAF-HOLLAND engineering, will void warranty and could lead to over torquing of fasteners or other component issues.

General Information

- The torque specifications are applied to the nut and NOT the bolt.

⚠ WARNING Failure to use the proper fasteners when servicing the suspension could cause component failure which, if not avoided, could result in death or serious injury.

⚠ WARNING Failure to properly torque all fasteners could result in component failure which, if not avoided, could result in death or serious injury.

Figure 24

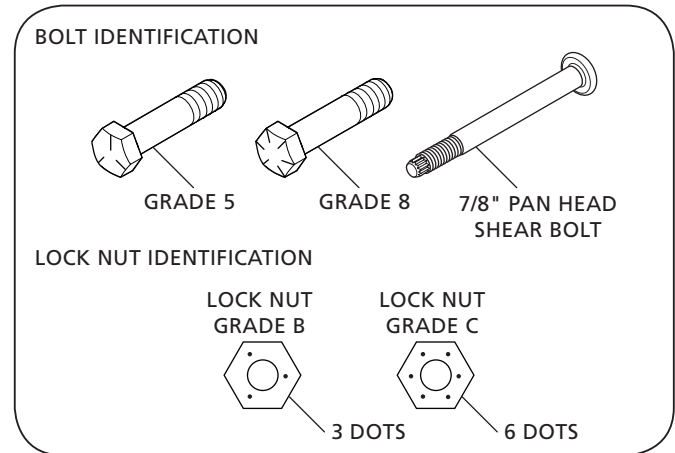

Service Manual

INTEGRAL[®] Disc Brake Axles Compact Bearing System



Contents	Page
Introduction.....	2
Warranty.....	2
Notes, Cautions, and Warnings	2
Section 1 – General Safety Instructions	3
Section 2 – General Service / Maintenance Instruction	4
Section 3 – Model Identification.....	5
Section 4 – Identification Tag	5
Exploded View and Parts List.....	6
Section 5 – Disc Brake/Hub Unit Inspection	7

Introduction

This manual provides the necessary information for the maintenance, inspection and safe operation of the SAF® disc brake system.

For axle end/brake replacement components contact SAF-HOLLAND® Customer Service at 888-396-6501.

Read this manual before using or servicing this product and keep it in a safe location for future reference. Updates to this manual, which are published as necessary, are available on the internet at www.safholland.us.

Use only SAF-HOLLAND® Original Parts to service your SAF-HOLLAND® INTEGRAL® disc brake axle. A list of technical support locations that supply SAF-HOLLAND® Original Parts and an Aftermarket Parts Catalog are available on the internet at www.safholland.us or contact Customer Service at 888-396-6501.

Warranty

Refer to the complete warranty for the country in which the product will be used. A copy of the written warranty is included with the product or available on the internet at www.safholland.us.

Contents	Page
Section 6 – Wheel Rock Test.....	10
Section 7 – Wheel Bearing Noise Test	10
Section 8 – Hub Unit Grease Leak Inspection.....	11
Section 9 – Servicing the Disc Brake/Hub Unit	12
Section 10 – Wheel Installation Procedure.....	18
Section 11 – Disc Brake Options.....	18
Section 12 – Torque Chart	20
Section 13 – Routine Service Schedule	21
Section 14 – Troubleshooting	22

Notes, Cautions, and Warnings

Knorr/Bendix is the manufacturer of the disc brake caliper assembly described in this service manual, NOT SAF-HOLLAND®. This manual references service documents which are published by Knorr/Bendix. The latest versions can be found on their website at www.bendix.com. These document references are intended to provide additional information when performing service work on the caliper assembly. SAF-HOLLAND® assumes no liability for the use of incorrect or unsuitable parts in the servicing or repair of the Knorr/Bendix disc brake caliper assembly. SAF-HOLLAND® assumes no liability for damages or claims arising out of incorrectly following procedures outlined in the Knorr/Bendix service manuals.

Knorr and Bendix are registered trademarks of the Knorr-Bremse Group.

Before starting any work on the unit, read and understand all the safety procedures presented in this manual. This manual contains the terms “NOTE”, “IMPORTANT”, “CAUTION”, and “WARNING” followed by important product information. These terms are defined as follows:

NOTE: Includes additional information to enable accurate and easy performance of procedures.

IMPORTANT: Includes additional information that if not followed could lead to hindered product performance.

CAUTION Used without the safety alert symbol, indicates a potentially hazardous situation which, if not avoided, could result in property damage.

⚠ CAUTION Indicates a potentially hazardous situation which, if not avoided, could result in minor or moderate injury.

⚠ WARNING Indicates a potentially hazardous situation which, if not avoided, could result in death or serious injury.

1. Safety Instructions

General and Servicing Safety Instructions

- Read and observe all Warning and Caution hazard alert messages. The alerts provide information that can help prevent serious personal injury, damage to components, or both.

▲WARNING Failure to follow the instructions and safety precautions in this manual could result in improper servicing or operation leading to component failure which, if not avoided, could result in death or serious injury.

- All maintenance should be performed by a properly trained technician using proper/special tools, and safe procedures.

NOTE: In the United States, workshop safety requirements are defined by federal and/or state Occupational Safety and Health Act (OSHA). Equivalent laws may exist in other countries. This manual is written based on the assumption that OSHA or other applicable employee safety regulations are followed by the location where work is performed.

- Properly support and secure the vehicle from unexpected movement when servicing the unit.

▲WARNING Failure to properly support and secure the vehicle and axles prior to commencing work could create a crush hazard which, if not avoided, could result in death or serious injury.

- If possible, unload the trailer before performing any service procedures.
- After pre-positioning the brake chamber, slack adjuster and/or ABS system as instructed in this manual, always consult the manufacturer's manual for proper operation.
- Service both roadside and curbside of an axle. Worn parts should be replaced in sets. Key components on each axle's braking system, such as friction material, rotors and drums will normally wear over time.
- DO NOT paint the wheel contact surfaces between the wheel and hub.

IMPORTANT: The wheel contact surfaces MUST be clean, smooth and free from grease.

▲WARNING Failure to keep wheel and hub contact surfaces clean and clear of foreign material could allow wheel/hub separations which, if not avoided, could result in death or serious injury.

- Only the wheel and tire sizes approved by the trailer builder can be used.

Operational and Road Safety Instructions

- Before operating vehicle, ensure that the maximum permissible axle load is NOT exceeded and that the load is distributed equally and uniformly.
- Make sure that the brakes are NOT overheated from continuous operation.

▲WARNING Failure to minimize the use of brakes during overheating conditions could result in deterioration of brake efficiency which could result in death or serious injury.

- The parking brake MUST NOT be immediately applied when the brakes are overheated.

CAUTION If the parking brake is immediately applied to the brakes when overheated, the brake drums or discs could be damaged by different stress fields during cooling.

- SAF® axles require routine service, inspection and maintenance in order to maintain optimum performance, and operational safety as well as an opportunity to recognize natural wear and defects before they become serious. Refer to the Routine Service Schedule in Section 12.

▲WARNING Failure to inspect and maintain your SAF-HOLLAND® INTEGRAL® disc brake axle as outlined in Section 12 can result in brake or wheel bearing failure which, if not avoided, could result in death or serious injury.

IMPORTANT: Use only SAF-HOLLAND® Original Parts to service your SAF-HOLLAND® INTEGRAL® disc brake axle.

▲WARNING Failure to maintain your SAF-HOLLAND® INTEGRAL® disc brake with SAF-HOLLAND® Original Parts can result in brake or wheel bearing failure which, if not avoided, could result in death or serious injury.

- Observe the operating recommendation of the trailer manufacturer for off-road operation of the installed axles.

IMPORTANT: The definition of OFF-ROAD means driving on non-asphalt/non-concrete routes, e.g. gravel roads, agricultural and forestry tracks, on construction sites and in gravel pits.

IMPORTANT: Off-road operation of axles beyond the approved application design could result in damage and impair suspension system performance.

- Follow the recommended routine maintenance and inspections described in this manual. These procedures are designed so that optimum performance and operational safety are achieved.
- Contact a qualified towing and/or service company to assist in repairing vehicle or to move it to a qualified repair facility.

2. General Service/Maintenance

1. Conduct regular visual checks of the brakes, tires and all chassis components. Refer to Section 12 for more information:
 - a. Inspect for secure mounting, wear, leaks, corrosion and damage.
 - b. Check for loose, broken or cracked air hoses, air system leaks, and damaged components.
 - c. Check that brake hoses and cables are properly secured.
 - d. For proper brake pad wear, check that there is enough clearance to allow the caliper full movement during normal operation.
2. Check the brake pads at regular service intervals to ensure that the brake pad hold down springs are in the correct position, and that brake pads are NOT worn beyond the minimum wear limits described in this manual.
3. When replacing brake pads, inspect the rotors for signs of wear, cracks, grooves, scoring or hot spots.
4. Visually check the brake caliper at regular service intervals as defined by the brake caliper manufacturer's basic inspection program. Refer to Section 5.3 of this manual for further information.
5. Check the spring brake chambers to make sure the parking springs are NOT caged in the released position. Be sure the dust plugs are properly installed.
6. Make sure that the vent holes in the air brake chamber are NOT covered with snow, ice, mud, etc.
7. Inspect the wheel bearing unit for grease leaks at every brake pad change.
8. Visually check the brake assembly (e.g. pads, rotor, etc.) for oil or grease contamination.
9. Check that all dust caps and boots are present and in good condition.
10. Regularly conduct general safety checks in accordance with any applicable laws.
11. After every wheel change, the wheel nuts MUST be re-tightened to the specified torque level after the initial 100 miles of operation, and then at every regular service interval.

CAUTION

Failure to re-tighten wheel nuts at specified intervals could result in component failure which, if not avoided, could result in damage to property.

Use only SAF-HOLLAND® Original Parts to service your SAF-HOLLAND® INTEGRAL® disc brake axle.

3. Model Identification

The disc brake axle serial tag is located near the center of the axle tube (**Figure 1**).

Figure 1

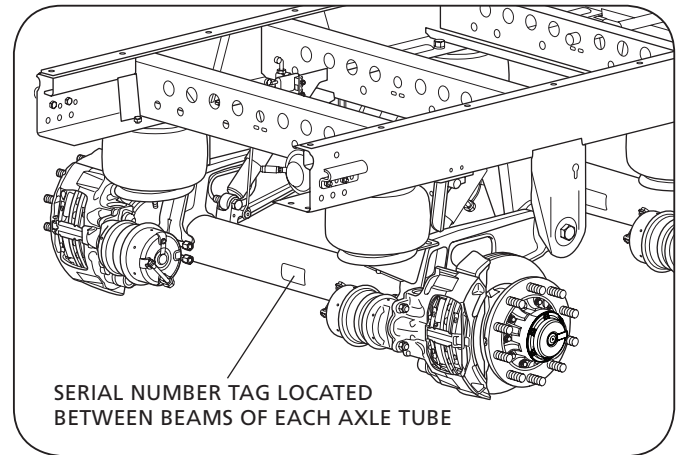

4. Identification Tag

The sample tag shown will help you interpret the information on the SAF-HOLLAND® USA, Inc. serial number tag. The model number, axle body part number and serial number are listed on the tag (**Figure 2**).

Record your tag numbers below for future quick reference.

Axle Body Part Number: _____

Model Number: _____

Serial Number: _____

Figure 2

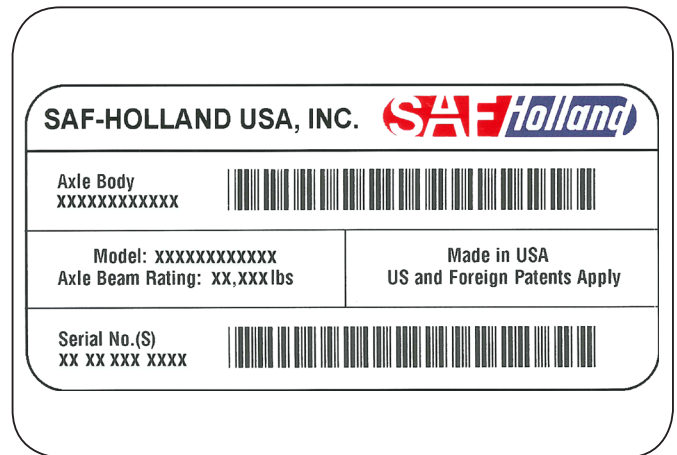

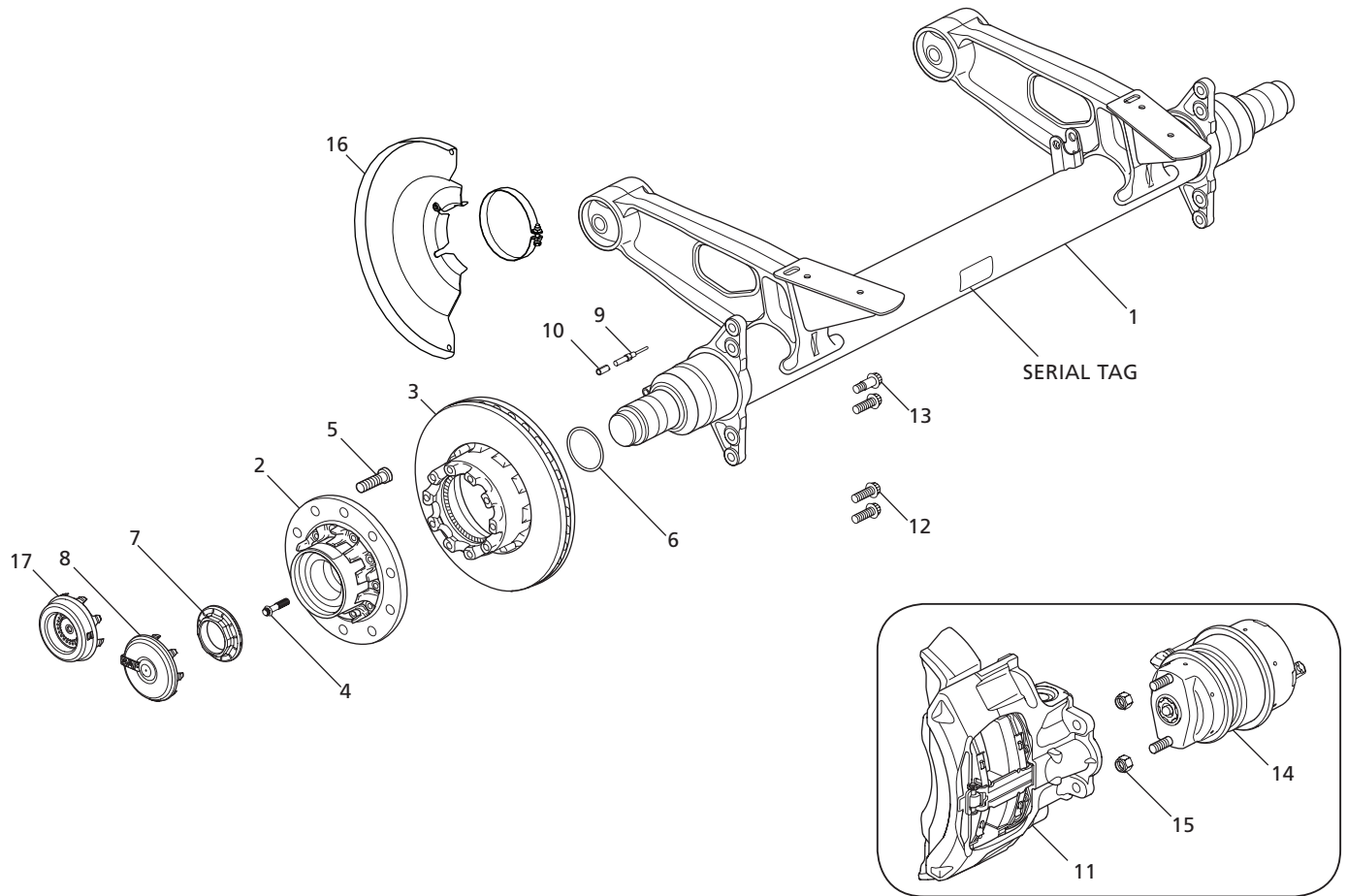

NOTE: Refer to the model number on the serial tag to identify your specific axle model's wheel end components. Contact SAF-HOLLAND® Customer Service at 888-396-6501.

ITEM NO.	DESCRIPTION	QTY. / AXLE
1	Axle Body	1
2	Hub with Compact Bearing	2
3	Rotor w/ Toner Ring	2
4	M 14 x 1.5 Bolt - Hub Rotor	20
5	Wheel Studs	20
6	O-Ring D92 x 4	2
7	Axle Nut Right-Hand Axle Nut Left-Hand	1
8	Hub Cap with Seal	2
9	ABS Sensor (WABCO)	2

ITEM NO.	DESCRIPTION	QTY. / AXLE
10	Clamping Bush	2
11	Brake Caliper SK7, Right Brake Caliper SK7, Left	1
12	M18 x 1.5 Bolt, Standard	6
13	M18 x 1.5 Bolt, Shoulder	2
14	Brake Chamber	2
15	Chamber Nut	4
16	Dust Shield (Optional)	2
17	Hub Odometer Cap (Optional)	1

5. Disc Brake/Hub Unit Inspection

IMPORTANT: During removal inspect components for wear and replace worn components.

⚠ WARNING Failure to properly support axle during maintenance could allow axle to fall which, if not avoided, could result in death or serious injury.

NOTE: For further disc brake inspection information, refer to the latest version of the TMC recommended practice RP 652—Service and Inspection of Air Disc Brakes (TMC DVD supplement).

5.1 Pad Wear Inspection

Check the brake pads for proper thickness at regular service intervals based on vehicle usage. Brake pad inspections should be carried out at least every three (3) months and in accordance with any legal requirements. Refer to "Routine Service Schedule" in Section 12.

NOTE: Regular service intervals could be required more frequently for severe duty applications. Refer to Section 12.

A quick visual inspection of the condition of the brake pads can be performed without removing the wheel:

1. Compare the position of the caliper marking to the carrier marking located on the underside of the caliper unit (**Figure 3**).
 - a. **Figure 3** - "View A" shows the positions of the two (2) markings when the brake pads are in good condition.
 - b. **Figure 3** - "View B" shows the positions of the two (2) markings when the wheel **MUST** be removed for further inspection of wear to the brake pads and brake rotor.

For further inspection of the brake pads, the wheel and brake pads **MUST** be removed. Refer to the Knorr/Bendix SK7 brake pad change service data sheet "SD-23-7541 Air Disc Brake" which can be found at www.bendix.com for more information.

IMPORTANT: After inspecting the brake pads, check that the brake system is functioning properly.

IMPORTANT: When replacing worn brake pads, **ALL** pads on the axle **MUST** be replaced.

If the friction material of the brake pad is less than 0.43" (11 mm) at its thinnest area, the brake pad **MUST** be replaced (**Figure 6**).

NOTE: Minor breakouts at the edges are permitted; major breakouts on the surface of the brake pad are **NOT** permitted (**Figure 4**).

Figure 3

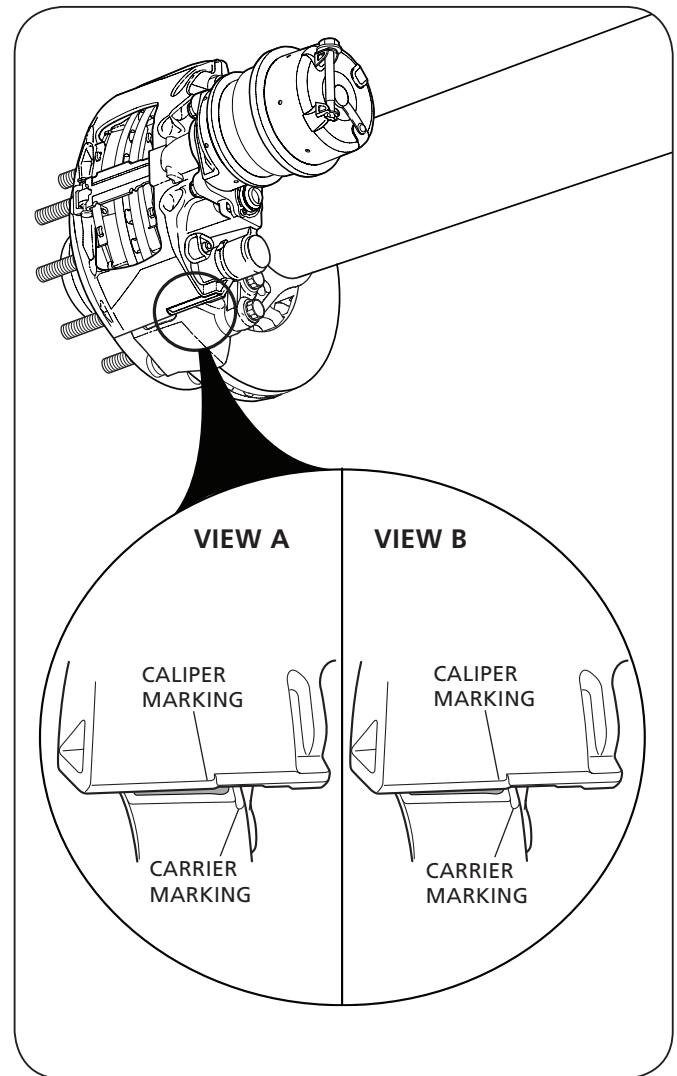
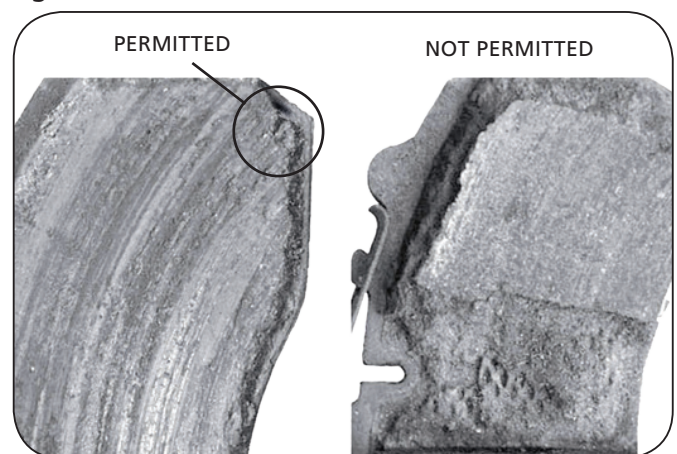

Figure 4



5.2 Rotor Wear Inspection

1. Carefully inspect both sides of the brake rotor friction surface (**Figure 5**).
 - a. Spider web cracking is acceptable (**Area A**).
 - b. Radial cracks less than 0.06" (1.5 mm) deep or wide and their length is less than 75% of the width of the rotor friction surface (**Area B**).
 - c. Grooves in the rotor surface are acceptable only if they are less than 0.06" (1.5 mm) deep (**Area C**).
 - d. Cracks that run completely to either edge of the hub are NOT acceptable, regardless of depth (**Area D**).
2. Measure the brake rotor thickness and re-surface, if necessary. For proper brake function, the minimum thickness for re-surfacing the brake rotor is defined as 1.54-1.57" (39-40 mm).

⚠ WARNING Re-surfacing the brake rotor beyond the minimum thickness could cause component failure which, if not avoided, could result in death or serious injury.

IMPORTANT: DO NOT use high-pressure cleaners or liquid cleaners on the brake rotor.

If the overall wear limits for the brake rotor and brake pads are exceeded (**Figure 6**), the rotor and pads **MUST** be replaced. Refer to brake pad and rotor replacement instructions as detailed in Section 9.1 and 9.2.

For both the inner and outer pads, the maximum brake pad wear difference is 0.2" (5.0 mm).

BRAKE ROTOR			BRAKE PAD	
DIAMETER	"A" NEW	"B" WEAR LIMIT	"C" NEW	"D" WEAR LIMIT
430 mm	45 mm	37 mm	30 mm	11 mm
16.93"	1.77"	1.46"	1.18"	0.43"

⚠ WARNING Failure to replace brake rotor and pads when minimum wear limits are reached could cause component failure which, if not avoided, could result in death or serious injury.

NOTE: When replacing the brake pads or brake rotor, use only Original SAF-HOLLAND® rotors and approved brake pads.

IMPORTANT: When replacing worn brake pads, all pads on the axle **MUST** be replaced.

NOTE: During brake repairs, conduct a visual inspection of the seals on the brake caliper. Refer to Section 5.3 for more information.

Figure 5

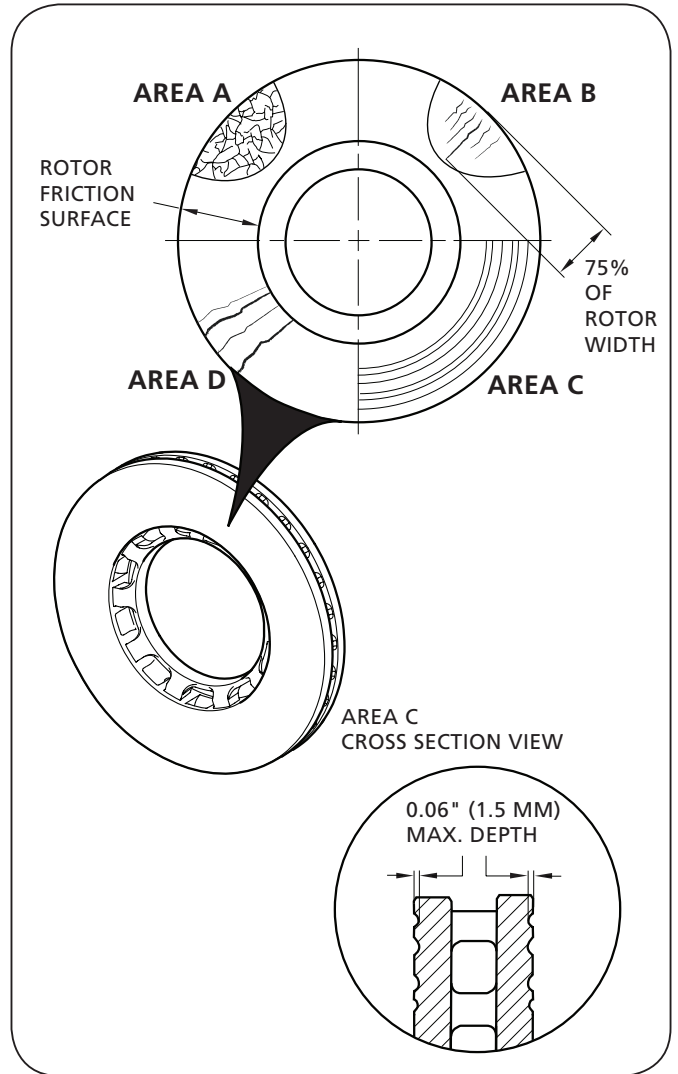
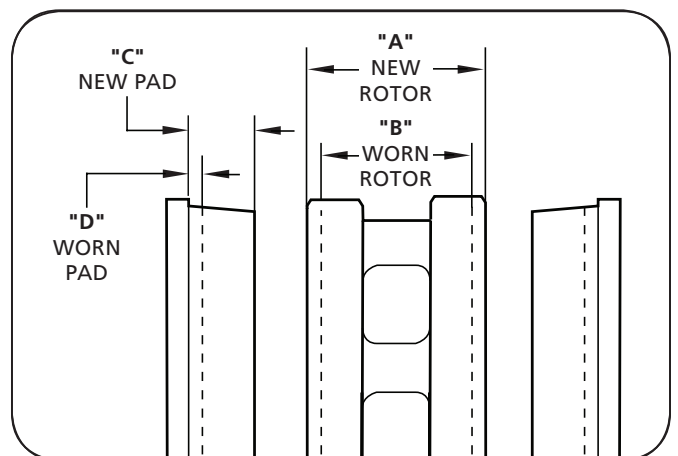

Figure 6



5.3 Brake Caliper Inspection

For instructions on brake caliper inspection and repair, refer to the Knorr/Bendix SK7 Caliper service data sheet "SD-23-7541 Air Disc Brake" which can be found at www.bendix.com.

5.4 Hub Unit Inspection

The SAF-HOLLAND® disc brake hub unit with compact bearing system is designed to be maintenance-free. If there is a malfunction with the hub unit, the hub unit including the compact bearing system **MUST** be replaced. The integrated compact bearing system is sealed and requires no additional grease or oil application to the bearing.

IMPORTANT: DO NOT remove the integrated compact bearing system. If there is a malfunction, the bearing system and hub unit **MUST** be replaced.

1. When changing brake pads and rotors or in the event of damage (e.g. brake overheating), inspect the bearing for signs of wear and grease leakage. Perform the Grease Leak Inspection, Wheel Rock Test and Wheel Bearing Noise Test as described in Sections 6 through 8.

⚠ WARNING Failure to replace bearing system and hub unit when required could cause component failure which, if not avoided, could result in death or serious injury.

2. Visually check the seal system to ensure that it is functioning properly and that there is minimal grease leakage. Refer to Section 8 for more information. For guidance about diagnosing seal system malfunctions refer to Section 13.

NOTE: Adjustment of the compact bearing system is NOT necessary.

IMPORTANT: DO NOT use high-pressure cleaners or liquid cleaners on the hub unit.

IMPORTANT: The red dot in the middle of the SAF® plastic hub cap is permanent. If you attempt to remove it, hub cap failure will result.

⚠ WARNING Failure to replace plastic hub cap when broken could cause component failure which, if not avoided, could result in death or serious injury.

6. Wheel Rock Test

1. For sufficient clearance to perform the test, raise the wheel off the ground. DO NOT remove the wheel!
2. Carefully remove the hub cap.
3. Using a size 85 mm socket, check the torque of the axle nut to ensure that it is torqued to 663 ft.-lbs. (900 N•m) by rotating the nut in either a left- or right-handed direction, for the roadside or curbside of the axle respectively.

NOTE: The SAF® compact bearing system uses a single piece spindle nut, which has a left-hand thread on the roadside of the axle and a right-hand thread on the curbside of the axle. The axle nut with a left-handed thread can be identified by a circular groove (**Figure 13**). The left-hand threaded axle spindle can be identified by a frontal groove on the end of the axle spindle.

4. Clean the surface of the axle nut. Attach the magnetic foot of the dial gauge to the surface of the nut and spindle. Place the pointer on the rim surface as shown (**Figure 7**).
5. Rock the wheel by first pulling at the top and pressing at the bottom, then pulling at the bottom and pressing at the top. Push and pull with approximately 50 lbs. (220 N) of force. While rocking/moving the wheel, record the end play shown on the dial gauge.

NOTE: Rotate the wheel several times before each measurement.

NOTE: If a recorded wheel end play of more than .01" (0.25 mm) while alternating +/- 50 lbs. (220 N) force is measured, the hub unit **MUST** be replaced.

7. Wheel Bearing Noise Test

1. For sufficient clearance to perform the test, raise the wheel off the ground. DO NOT remove the wheel!
2. Carefully remove the hub cap.
3. Using a size 85 mm socket, check the torque of the axle nut to ensure that it is torqued to 663 ft.-lbs. (900 N•m).
4. Rotate the wheel in both forward and rearward directions, using varying speeds (**Figure 8**).
5. If the bearing feels rough and/or a "grinding" noise is heard, the hub **MUST** be replaced.

NOTE: Noises can also be caused by the brakes. Before removing the hub unit, remove the brake pads and repeat the bearing noise test.

Figure 7

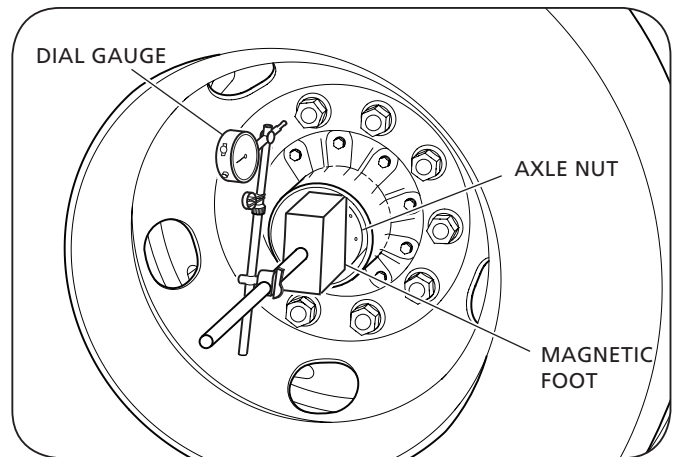
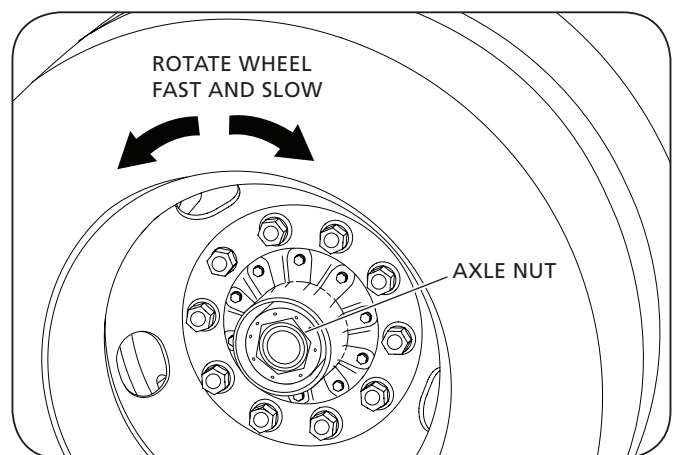

Figure 8



8. Hub Unit Grease Leak Inspection

A hub unit grease leak inspection should be performed if more than half of the wheel flange is covered with grease.

1. Carefully remove the hub cap.
2. Inspect the grease levels inside of the wheel flange including the inside of the hub cap, the axle nut, axle tube spindle and hub seal.
 - a. If the hub seal is **NOT** completely covered with grease (**Figure 9**), the hub units are correct and **DO NOT** need replacement.
 - b. If the hub seal is completely covered with tar-like grease (**Figure 10**), the hub unit **MUST** be replaced.

NOTE: There may be a small amount of grease on the lower edge of the hub seal. This is normal, and **DOES NOT** indicate grease leakage.

Figure 9



Figure 10



9. Disc Brake/Hub Unit Service

Contact SAF-HOLLAND® Customer Service at 888-396-6501 before performing any work on the SAF-HOLLAND® INTEGRAL® disc brake hub unit.

IMPORTANT: Only qualified mechanics should perform the procedures detailed in this manual.

NOTE: If the seal between the axle spindle and spindle nut is broken before the end of the stated warranty period, all warranty coverage will be invalidated unless the repair work has been approved by SAF-HOLLAND®. For approval, contact Customer Service at 888-396-6501.

IMPORTANT: During removal inspect components for wear and replace worn components.

⚠ WARNING Failure to properly support axle during maintenance could allow axle to fall which, if not avoided, could result in death or serious injury.

⚠ CAUTION DO NOT hit steel parts with a steel hammer as parts could break, sending flying steel fragments in any direction creating a hazard which, if not avoided, could result in minor to moderate injury.

NOTE: For certain service and repair work, some bolts MUST be replaced. DO NOT oil or grease bolts for installation. Tighten bolts with a torque wrench following the specified procedure and torque value. Refer to Torque Chart in Section 11.

9.1 Brake Pad Replacement

For instructions on brake replacement, refer to the Knorr/Bendix SK7 Caliper service data sheet "SD-23-7541 Air Disc Brake" which can be found at www.bendix.com.

IMPORTANT: After inspecting the brake pads, check that the brake system is functioning properly.

IMPORTANT: When replacing worn brake pads, all pads on the axle MUST be replaced.

9.2 Rotor Replacement

⚠ WARNING Failure to observe these instructions could cause component failure which, if not avoided, could result in death or serious injury.

1. Cage the spring brake.
2. Remove the ABS sensor by following the instructions detailed in Section 10.1.
3. Remove the brake chamber from the brake caliper by loosening and removing the two (2) mounting nuts (**Figure 11**).
4. Remove the brake caliper from the brake spider by using a size 24 mm socket to loosen and discard all four (4) brake caliper bolts (**Figure 12**).
5. Using a hub cap puller, remove the plastic hub cap (**Figure 13**) at the reinforced undercut on the side of the cap.

IMPORTANT: The red dot in the middle of the SAF® plastic hub cap is permanent and **MUST NOT** be removed.

6. Using a size 85 mm socket, remove the axle spindle nut by rotating the nut in either a left- or right-handed direction, respectively for the road or curbside of the axle.

NOTE: The SAF® compact bearing system uses a single piece spindle nut which has a left-hand thread on the roadside of the axle and a right-hand thread on the curbside of the axle. The axle nut with a left-handed thread can be identified by a circular groove (**Figure 13**). The left-hand threaded axle spindle can be identified by a frontal groove on the end of the axle spindle.

NOTE: DO NOT remove the SAF® compact bearing spindle nut with an impact wrench. Due to the self-tightening design of the SAF® compact bearing spindle nuts, it may be necessary to apply high torque of up to 1,600 ft.-lbs. (2,170 N•m) to loosen the spindle nuts. Use an appropriate length hand wrench and torque multiplier to loosen the SAF® compact bearing spindle nut.

IMPORTANT: DO NOT use an impact wrench to remove the SAF® compact bearing spindle nut.

⚠ CAUTION The high speed generated from air impact wrench to loosen the high clamp load of the SAF® compact bearing spindle nut could result in damage to the spindle threads.

Figure 11

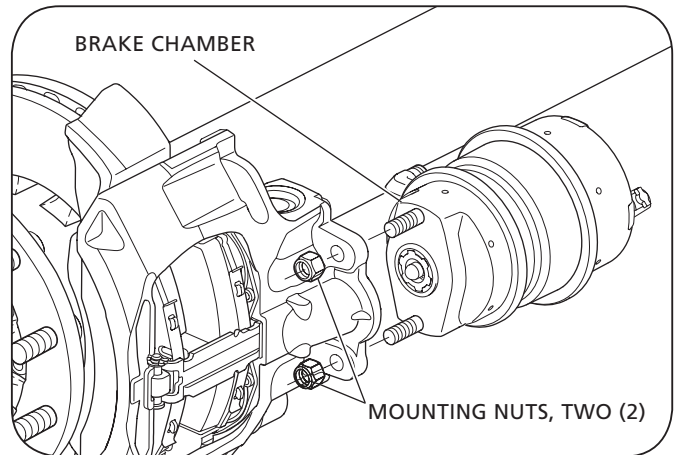

Figure 12

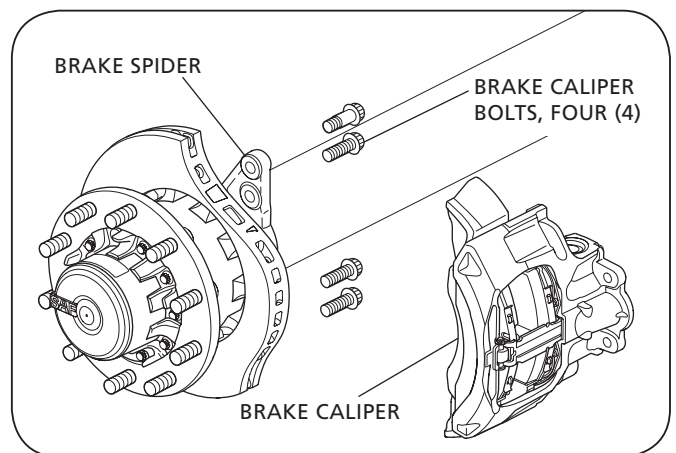
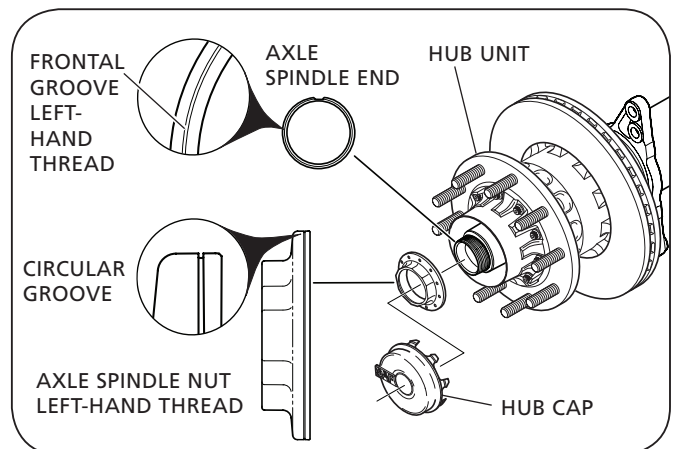

Figure 13



7. Remove the head unit by gently sliding it off the spindle. **(Figure 14).**
8. Remove the bearing O-Ring seal from the hub unit and discard **(Figure 15).**

NOTE: The O-Ring seal may be stuck to the bearing system or on the axle spindle.

9. Clean the hub unit bearing surface.
10. Remove the hub unit from the rotor by using a size 15 mm socket to loosen and discard all ten (10) connection bolts **(Figure 15).**
11. Clean the rotor contact surface on the hub unit. Using compressed air, clean the tapped holes in the disc unit. Check that the threads are in good working conditions.
12. Re-install the hub unit to the rotor by using ten (10) new SAF® specific connection bolts. Use a torque wrench to pre-torque the bolts to 37 ft.-lbs. (50 N•m). For final torque, tighten the bolts with an additional 120° turn using a criss-cross pattern. Refer to the Torque Chart in Section 11 for more information.

IMPORTANT: When re-installing the hub unit and rotor, use only new SAF® specific connection bolts. Bolts **MUST** be clean and free of oil and grease.

⚠ WARNING Failure to observe these instructions could cause component failure which, if not avoided, could result in death or serious injury.

13. Clean any grease residues from the axle spindle end and re-coat the bearing journal with Renolit Paste AZ 0-1. **DO NOT** grease or oil the spindle threads.

NOTE: Renolit Paste AZ 0-1 is available in 5 g packets through SAF-HOLLAND® Original Parts online at www.safholland.us or by contacting Customer Service at 888-396-6501.

IMPORTANT: **DO NOT** use high-pressure cleaners or liquid cleaners on the spindle.

14. Insert a new bearing O-Ring seal into the groove of the hub unit **(Figure 16).**
15. Re-install the head unit by gently sliding it on the spindle **(Figure 14).** During re-installation be sure the O-Ring seal is in the proper position.

Figure 14

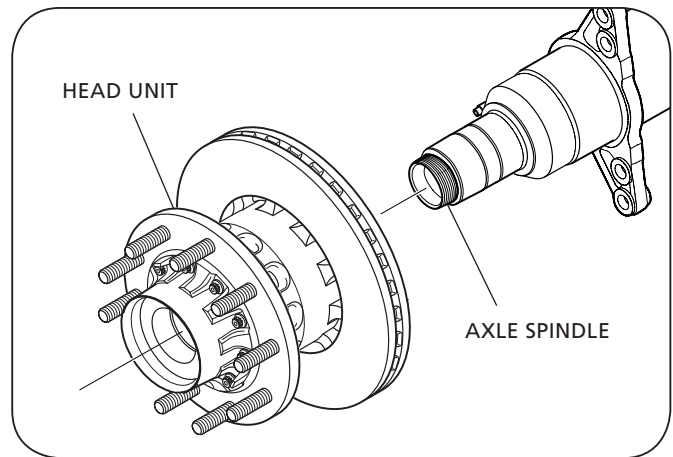

Figure 15

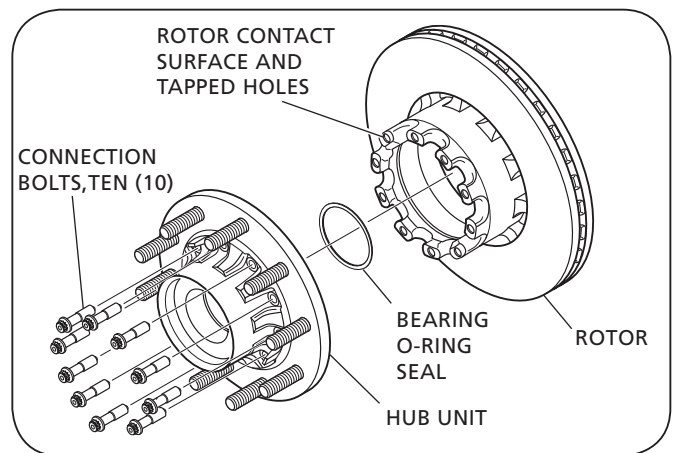
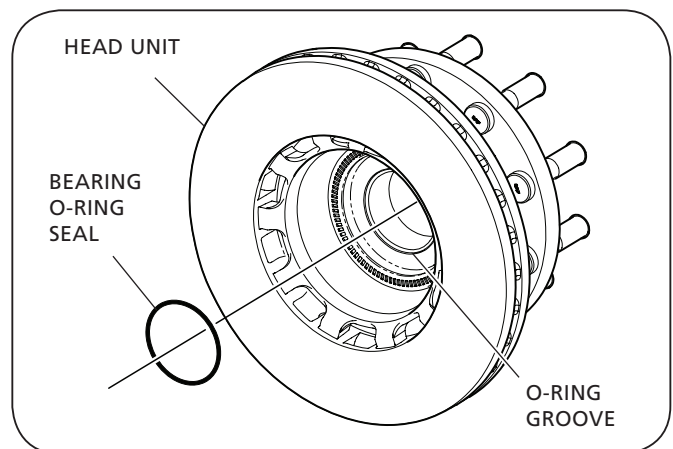

Figure 16



16. Re-install the SAF® specific axle spindle nut by rotating the nut onto the axle spindle in either a left-or right-handed direction, depending on the direction of the thread:

NOTE: The SAF® compact bearing system uses a single piece spindle nut which has a left-hand thread on the roadside of the axle and a right-hand thread on the curbside of the axle. The axle nut with a left-handed thread can be identified by a circular groove. The left-hand threaded axle spindle can be identified by a frontal groove on the end of the axle spindle (**Figure 13**).

- Pre-torque the axle spindle nut with a torque wrench and size 85 mm socket to 110 ft.- lbs. (150 N•m).
- Rotate the head unit slowly five (5) revolutions.
- For final torque tighten the axle spindle nut by 1/12 turn (30°).

NOTE: Each mark on the spindle nut equals 1/12 (30°) turn (**Figure 17**).

- Check that the axle spindle nut has a final torque of 663 ft.-lbs. (900 N•m). Refer to the Torque Chart in Section 11.

NOTE: The maximum permissible end play of the hub unit is shown in Section 6.

17. Check that the hub cap O-Ring seal is in good condition and replace if necessary.
18. Re-install the hub cap onto the hub unit by pressing it slowly and uniformly against the hub seat until the snap fit is secure (**Figure 17**). Visually inspect for a proper O-Ring seal.
19. Re-install the caliper to the brake spider using four (4) new SAF® specific brake caliper bolts (**Figure 18**).

Figure 17

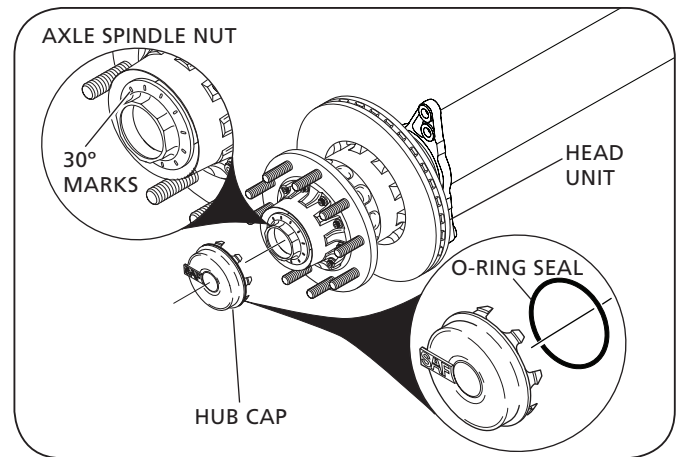
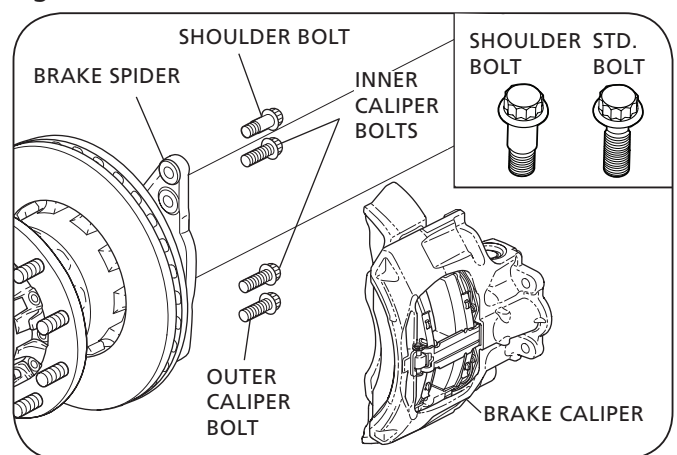

Figure 18



NOTE: The caliper is connected to the disc brake spider using four (4) SAF® specific bolts: three (3) standard bolts and one (1) shoulder bolt (**Figure 19**). The shoulder bolt is located at the outer mounting hole where the brake rotor rotates OUT of the caliper when turning in driving direction (**Figure 19**).

⚠ WARNING Failure to install the shoulder bolt in the proper location could cause component failure which, if not avoided, could result in death or serious injury.

- Pre-torque the bolts to 88 ft.-lbs. (120 N•m) from inner bolts to outer bolts using a size 24 mm socket.
- Verify the pre-torque of the bolts a second time, and if necessary re-tighten all bolts to 88 ft.-lbs. (120 N•m).
- Final torque from inner bolts to outer bolts to 331 +/- 22 ft.-lbs. (450 +/- 30 N•m).

IMPORTANT: Make sure that the brake caliper is mounted on the correct side of the axle. The correct location can be identified by the lengths of the guide pins on the caliper unit. The longer guide pins should be located on the bottom of the caliper unit when installed on the axle in driving direction. The shorter guide pins should be located on the top of the caliper unit (**Figure 20 and 21**).

- Re-install the SAF® brake chamber by following the instructions in "SAF® Brake Cylinders for Disc Brakes Installation and Service Guide" available online at www.safholland.us.
- Re-install the ABS sensor by following the instructions detailed in Section 10.1.
- To enable the ABS sensor to function properly press the ABS sensor against the toner ring at the hub unit to eliminate any clearance between these parts.

IMPORTANT: After replacing the rotor, verify that the brake system is functioning properly.

9.3 Brake Caliper Servicing

For instructions on brake caliper and repair/replacement, refer to the Knorr/Bendix SK7 Caliper service data sheet "SD-23-7541 Air Disc Brake" which can be found at www.bendix.com.

Figure 19

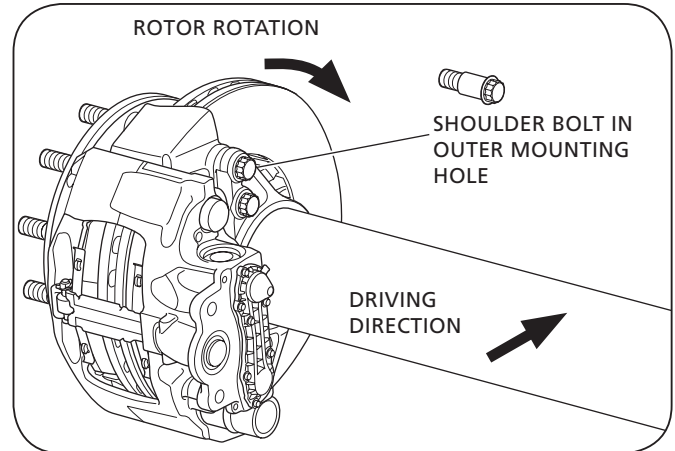

Figure 20

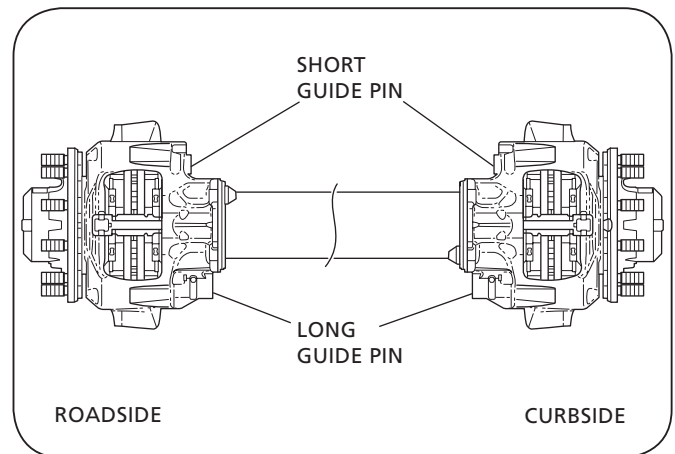
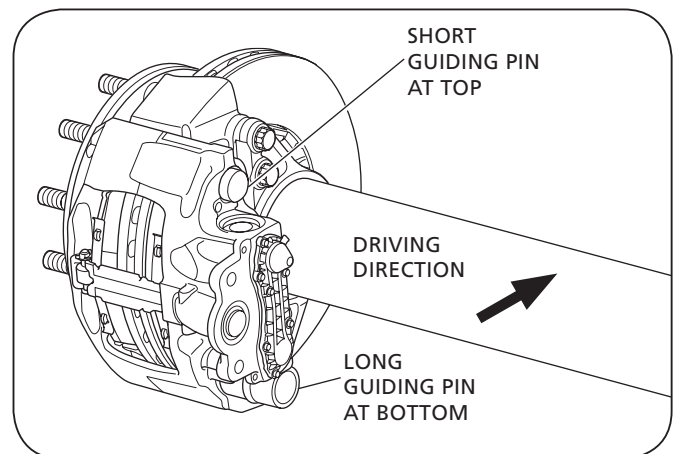

Figure 21



9.4 Hub Unit Servicing

The SAF-HOLLAND® disc brake hub unit with compact bearing system is designed to be maintenance-free. If there is a malfunction with the hub unit, the hub unit including the compact bearing system **MUST** be replaced. The integrated compact bearing system is lifetime sealed and requires no grease or oil application to the bearing.

IMPORTANT: DO NOT remove the integrated compact bearing system. If there is a malfunction, the bearing system and hub unit **MUST** be replaced.

When replacing the wheel bolts, refer to the hub removal instructions described in Section 9.2

NOTE: Not all bolts may need to be replaced. Only replace bolts that are damaged or in need of replacement.

1. Remove the wheel bolts by pressing them out of the hub unit and discard (**Figure 22**).
2. Install new wheel bolts by pressing them into the hub unit. To ensure correct alignment of the bolts during installation, position the flat side of each wheel bolt head so that it is facing the center of the hub (**Figure 23**).

CAUTION DO NOT hit steel parts with a steel hammer as parts could break, sending flying steel fragments in any direction creating a hazard which, if not avoided, could result in minor to moderate injury.

Figure 22

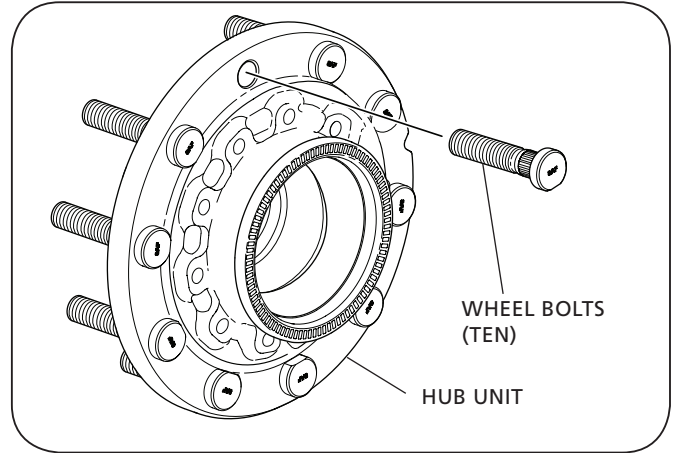
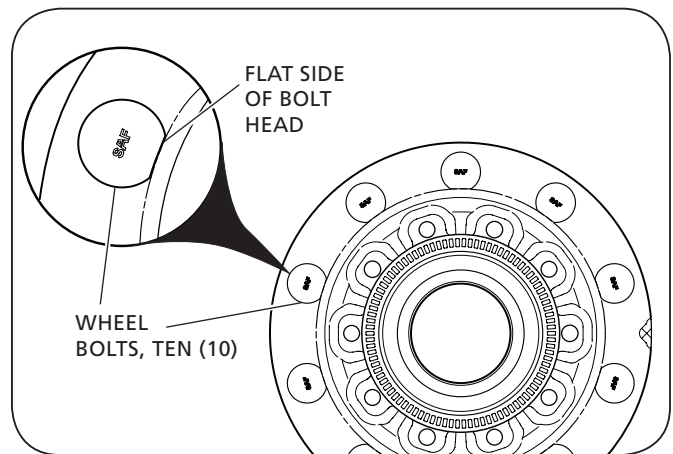

Figure 23



10. Wheel Installation Procedure

The following information is intended to provide basic wheel installation instructions. Refer to TMC RP222C for complete installation details.

1. Clean all mating surfaces on hub, wheels and nuts.
2. Rotate the hub so a pilot boss is at the top (12 o'clock) position.
3. Mount wheel(s) on hub. One or more of the wheel nuts can be started in order to hold wheel in position.
4. Tighten the top wheel nut first. Apply 50 ft.-lbs. (68 N•m) of torque to draw the wheel up fully against the hub.
5. Install remaining wheel nuts. Using sequence shown in **(Figure 24)**, tighten all wheel nuts to 50 ft.-lbs. (68 N•m) of torque.
6. Repeating sequence shown in **(Figure 24)**, retighten all wheel nuts to 475 ± 25 ft. lbs. (644 ± 34 N•m) of torque.
7. Check seating of wheel at the pilot bosses. Rotate wheel and check for any rotational irregularity.

⚠ WARNING Retorque all wheel nuts after 5 to 100 miles of service on the initial "in-service" following any installation of wheel to hub assembly.

11. Disc Brake Options

11.1 ABS Sensor Replacement

NOTE: When replacing the ABS sensor, only install a sensor manufactured by WABCO. DO NOT mix sensors from different manufacturers. The SAF-HOLLAND® INTEGRAL® Disc Brake comes with a WABCO ABS mini sensor Ø11. For further ABS sensor information, contact SAF-HOLLAND® Customer Service at 888-396-6501.

1. Disconnect the ABS sensor.
2. Remove the ABS sensor from the sensor holder by pulling it straight out from the holder and discard **(Figure 25)**.
3. If necessary, remove the sensor retaining spring clip from the sensor holder and replace with new clip. **(Figure 25)**.
4. Install a new ABS sensor by pushing it directly into the sensor holder/spring clip until it contacts the tooth wheel in the hub unit **(Figure 25)**.
5. Re-connect the ABS sensor.

Figure 24

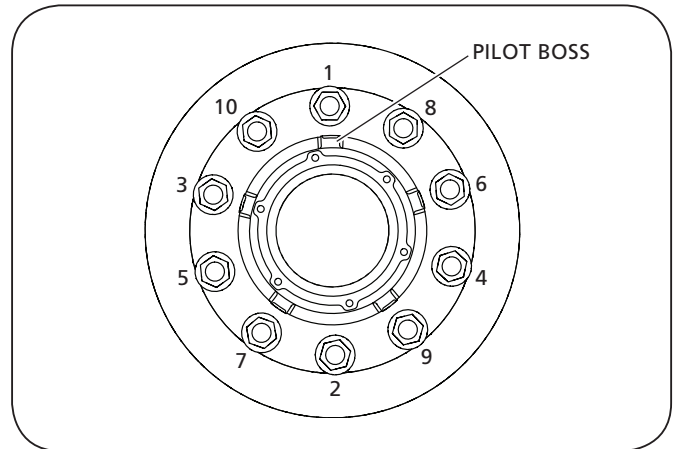
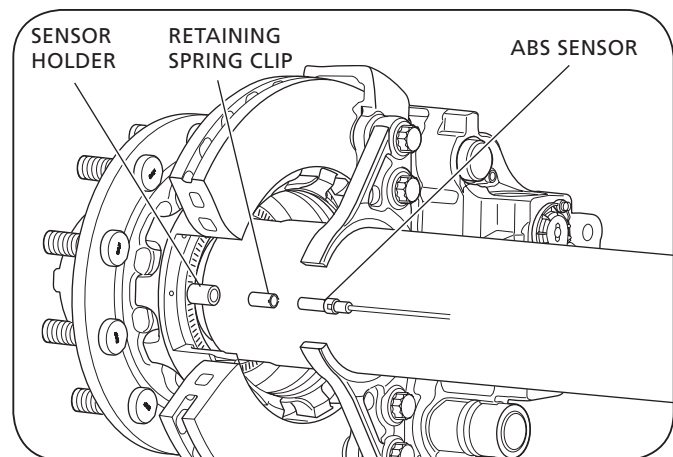

Figure 25



11.2 Hubodometer

The SAF-HOLLAND® INTEGRAL® Disc Brake can be factory equipped or retrofitted with a hubodometer hub cap for installation of a hubodometer.

1. Remove the original plastic hub cap (**Figure 26**) at the reinforced undercut on the side of the cap using a hub cap puller.
2. Install hubodometer onto hubodometer hub cap.
3. Check that the hubodometer hub cap O-Ring is installed correctly and is in good condition.
4. Install the hubodometer hub cap by pressing it slowly and uniformly against the hub seat until the snap fit is secure (**Figure 27**). Visually inspect the O-Ring for a proper seal.

NOTE: A hubodometer hub cap cannot be installed on axles equipped with a Tire Inflation System (TIS).

11.3 Tire Inflation System

If your system is prepped for a Tire Inflation System, contact SAF-HOLLAND® Customer Service for further information and installation instructions.

11.4 Dust Shield

The SAF-HOLLAND® INTEGRAL® Disc Brake can be factory equipped or retrofitted with a dust shield.

Refer to **Figure 28** for the following instructions:

1. Using a 13mm socket, loosen and remove the dust shield clamp band bolt.
2. Wrap the clamp band around the axle and loosely install the clamp band bolt.
3. Position the clamp band around the axle.
4. Route any ABS sensor wires through one of the two rubber grommets on the dust shield.
5. Position the clamp band over the clamp band lip portion of the dust shield.
6. Slide the dust shield and clamp band together toward the disc brake until the clamp band is about 12mm (0.5") from the brake rotor, pulling the ABS sensor wire through the rubber grommet as necessary.
7. Torque the clamp band bolt to 20-25 ft.-lbs. (27-34 N•m).
8. Use a pry bar and/or rubber mallet to ensure that there is clearance between the dust shield and the rotor.
9. Plug the ABS sensor into the abs system wire.

Figure 26

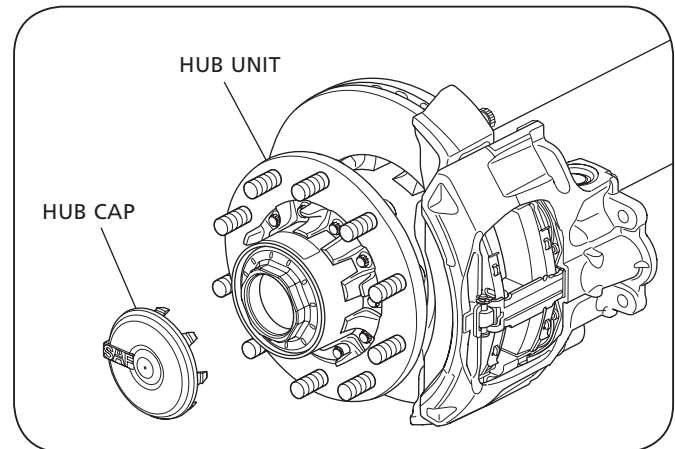

Figure 27

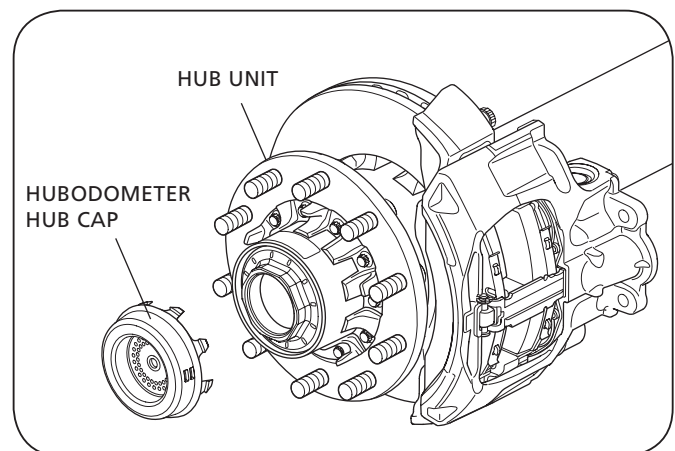
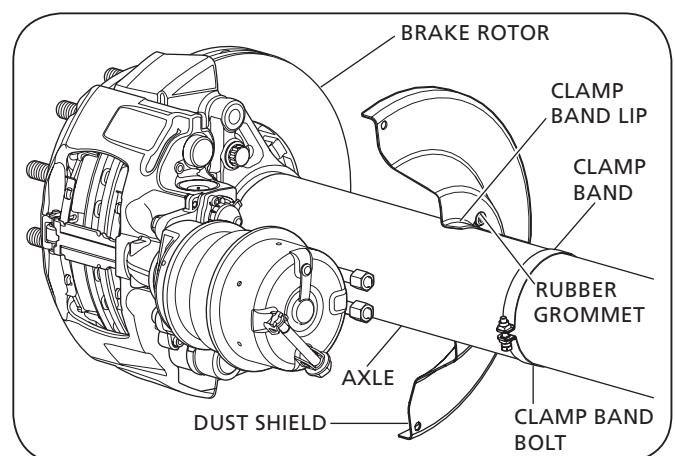

Figure 28



12. Torque Chart

PART	APPLICATION	TORQUE SPECIFICATIONS
SAF® Specific Axle Spindle Nut M75 x 1.5	Compact Bearing System	<p>Left-hand thread located on the roadside of the axle. Right-hand thread located on the curbside of the axle. The axle nut with a left-handed thread can be identified by a circular groove (Figure 13).</p> <ol style="list-style-type: none"> 1. Pre-torque with a size 85 mm socket to 110 ft.-lbs. (150 N•m). 2. Rotate the head unit slowly five (5) revolutions. 3. For final torque tighten the axle spindle nut by 1/12 turn (30°). 4. Check that the axle spindle nut has a final torque of at least 663 ft.-lbs. (900 N•m). <p>Maximum permissible end play of the hub unit is shown in Section 6.</p>
SAF® Specific INTEGRAL® Bolt M14 x 1.5	Rotor - Hub	<p>Torque all ten (10) bolts in a criss-cross pattern.</p> <ol style="list-style-type: none"> 1. Pre-torque to 37 ft.-lbs. (50 N•m). 2. For final torque tighten by an additional 120° turn.
SAF® Specific Caliper Bolt M18 x 1.5	Caliper - Spider	<p>Torque bolts from inner bolts to outer bolts.</p> <ol style="list-style-type: none"> 1. Pre-torque to 88 ft.-lbs. (120 N•m). 2. Verify the pre-torque of the bolts a second time, and, if necessary re-tighten all bolts to 88 ft.-lbs. (120 N•m). 3. Final torque from inner bolts to outer bolts to 331 +/- 22 ft.-lbs. (450 +/- 30 N•m).
SAF® Specific Brake Chamber Nut 5/8" -11 UNC Nylock or M16 x 1.5"	Brake Chamber	<ol style="list-style-type: none"> 1. Pre-torque both chamber nuts to 60-75 ft.-lbs. (80-100 N•m). 2. For final torque tighten both chamber nuts to 130-155 ft.-lbs. (180-210 N•m)

13. Routine Service Schedule

⚠️ WARNING Failure to inspect and maintain your SAF-HOLLAND® INTEGRAL® disc brake axle as outlined in Section 12 can result in brake or wheel bearing failure which, if not avoided, could result in death or serious injury.

⚠️ WARNING Failure to maintain your SAF-HOLLAND® INTEGRAL® disc brake with SAF-HOLLAND® Original Parts can result in brake or wheel bearing failure which, if not avoided, could result in death or serious injury.

IMPORTANT: Use only SAF-HOLLAND® Original Parts to service your SAF-HOLLAND® INTEGRAL® disc brake axle.

WHICHEVER OCCURS FIRST	PERIODIC CHECKS				
	MILEAGE INTERVALS	After First 3,000 Miles	Daily	Every 20,000 Miles	Every 50,000 Miles
	TIME INTERVALS	After First Month		Every 3 Months	Every 6 Months
VISUAL AND SAFETY INSPECTION					
Inspect for missing, or loose hubcap.			•		
Inspect for grease leakage around hubcap.			•		
Hub unit maintenance-free. Check for grease leaks. Refer to Section 8.				•	
Inspect the brake caliper guide system. Check for free movement and sliding action. Refer to Section 5.3.					•
Check rubber dust covers for cracks and damage. Check adjuster cap for correct seating. Refer to Section 5.3.					•
Inspect brake pad thickness regularly. Refer to Section 5.				•	
Inspect brake rotors for cracks. Refer to Section 5.					•
Perform general service / maintenance inspection. Refer to Section 4.		•			
Perform disc brake / hub unit inspection. Refer to Section 5.		•			•
Perform wheel rock and wheel noise tests. Refer to Section 6 and 7.				•	

MECHANICAL CHECK

Attention: Check torque of wheel nuts after the first 5-100 miles (8-160 km) from date vehicle was placed into service and after every wheel removal. Continually check wheel torque every 10,000 miles (16,000 km), or at the intervals indicated in your vehicle owner's manual, whichever occurs first.

SPECIAL SERVICE CONDITIONS

Vehicles with long standing periods.	Service at specified time intervals, e.g. trailer used for storage or frequently left standing for several days at a time.
Vehicles used under severe duty and extreme conditions.	Service at suitably reduced intervals, e.g. trailer operating in continuous multi-shifts or in off-road construction sites.

14. Troubleshooting Chart (SAF-HOLLAND® suspensions equipped with disc brake axles)

PROBLEM	POSSIBLE CAUSE	POSSIBLE REMEDY
Brakes will NOT release	Disc brake caliper bound up	Lubricate or replace brake caliper
	Brake hoses restricted	Replace hoses
	Brake control valve restricted/inoperable	Repair/replace control valve
	Brake out of adjustment	Adjust brake/repair or replace automatic adjustment device as necessary
	Damaged brake chamber	Replace brake chamber
	Damaged brake assembly	Replace or repair brake assembly
	Supply air interrupted	Open glad hand cut-out cock or push brake control valve in
	Supply line improperly coupled	Properly couple supply air line
	Brake pads frozen to rotor in cold weather	Warm brakes
No brakes or insufficient brake performance	Service air interrupted	Open glad hand cut-out cock
	Service air line improperly coupled	Properly couple service air line
	Brake hoses restricted	Relieve restriction or obstruction or replace hoses
	Brake control valve restricted/inoperable	Repair/replace control valve
	Brake out of adjustment	Adjust brake/repair or replace automatic adjustment device as necessary
	Damaged brake chamber	Replace brake chamber
	Damaged brake assembly	Replace or repair brake assembly
Dragging Brakes/Slow brake application or release timing	Brake hoses restricted	Relieve restriction or obstruction or replace hoses
	Brake control valve restricted/inoperable	Repair/replace control valve
	Brake out of adjustment	Adjust brake/repair or replace automatic adjustment device as necessary
	Damaged brake chamber	Replace brake chamber
	Damaged brake assembly	Replace or repair brake assembly
Dog tracking	Axle not properly aligned	Align axle
	Slider assembly racked or NOT aligned properly	Repair or replace slider assembly
	Frame bent or NOT aligned properly	Repair or align frame
	Damaged suspension component	Repair or replace suspension component
	Bent axle	Replace axle
Uneven tire wear	Improper tire inflation	Inflate tire to proper pressure
	Loose wheel stud nuts	Inspect for and repair any resultant wheel end damage and tighten properly
	Improper wheel bearing adjustment	Inspect for and repair any resultant wheel end damage and adjust properly
	Axle NOT properly aligned	Align axle
	Slider assembly racked or NOT aligned properly	Repair or replace slider assembly
	Frame bent or NOT aligned properly	Repair or align frame
	Damaged suspension component	Repair or replace suspension component
	Bent axle	Replace axle
	Mismatched tire sizes	Properly match tire sizes
	Unequal brake balance or timing	Repair brakes as necessary
	Overly aggressive braking	Instruct/train driver in proper brake use
	High speed turns	Instruct/train driver in proper vehicle speeds
	High level of side scrub	Instruct/train driver in proper vehicle maneuvering
Anti-Lock Brake System malfunction	Refer to ABS manufacturer's service literature	

PROBLEM	POSSIBLE CAUSE	POSSIBLE REMEDY
Grabbing brakes	Contaminants on brake lining	Replace brake pads
	Brake out of adjustment	Adjust brake/repair or replace automatic adjustment device as necessary
	Warped brake rotor	Machine or replace brake rotor
	Damaged brake chamber	Replace brake chamber
	Damaged brake assembly	Replace or repair brake assembly
	Unequal brake balance or timing	Repair brakes as necessary
	Anti-Lock Brake System malfunction	Refer to ABS manufacturer's service literature
Excessive heat cracks in rotor	Brake out of adjustment	Adjust brake/repair or replace automatic adjustment device as necessary
	Overly aggressive braking	Instruct/train driver in proper brake use
	Unequal brake balance or timing	Repair brakes as necessary
	Anti-Lock Brake System malfunction	Refer to ABS manufacturer's service literature
	Damaged brake chamber	Replace brake chamber
	Damaged brake assembly	Replace or repair brake assembly

Service Manual for Drum Brake Axles

Tapered and Parallel Spindle Axles

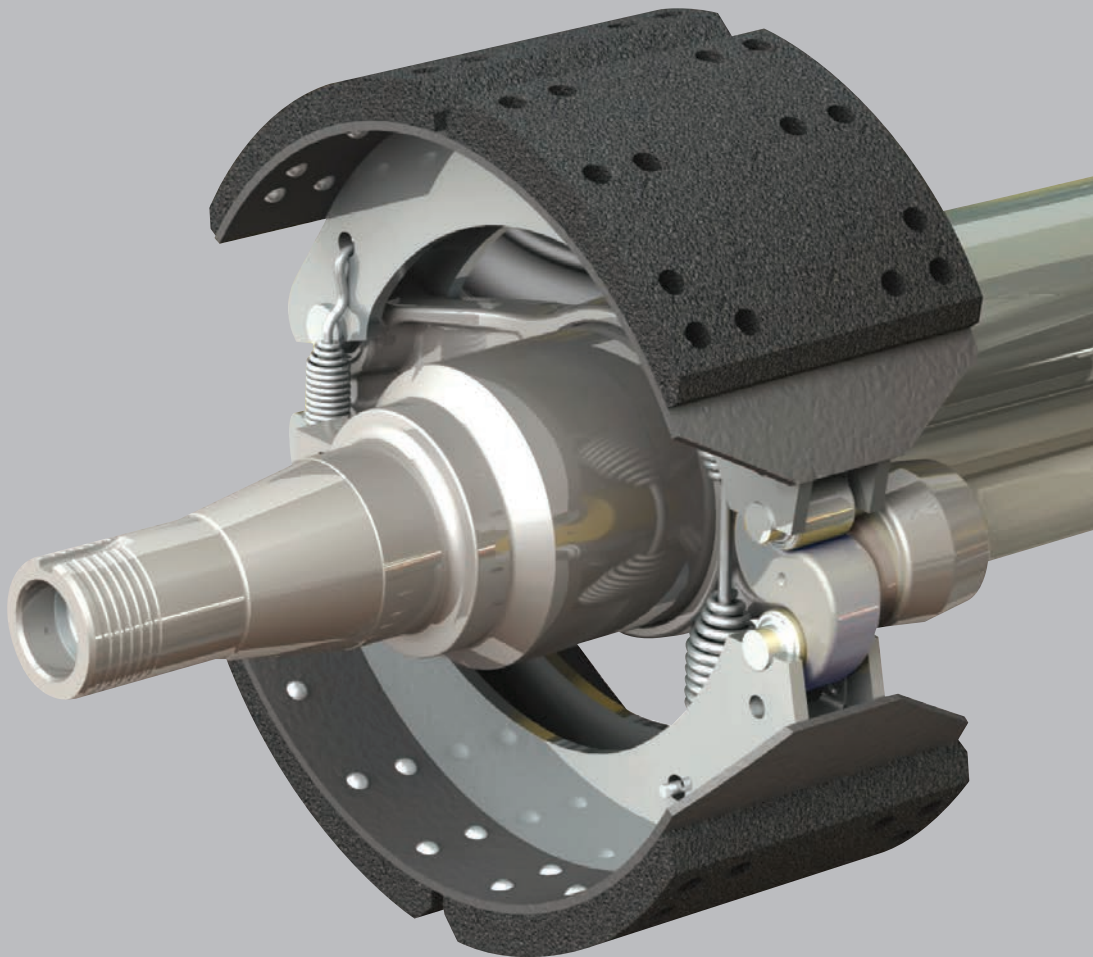

Contents	Page
Introduction.....	2
Warranty.....	2
Notes, Cautions, and Warnings	2
Section 1 – General Safety Instructions	3
Section 2 – Model Identification.....	5
Section 3 – Identification Tag	5
Brake Components Parts List Prior to November 30, 2012.....	6
Brake Components Parts List After November 30, 2012.....	7
Section 4 – Hubs, Bearings and Seal Removal.....	8
Section 5 – Bearing Inspection	10
Section 6 – Hubs, Bearings and Seal Installation.....	11
Section 7 – Hub Bearing Adjustment	13
Section 8 – Hub Cap Installation	15
Section 9 – Filling Hub with Lubricant (Oil Based)	15

Contents	Page
Section 10 – Retracting the Brake Shoes or Slack Adjuster Control Arm(s).....	16
Section 11 – Brake Shoe Removal	17
Section 12 – Brake Shoe Installation	19
Section 13 – Brake Adjuster Removal	22
Section 14 – Brake Adjuster Installation	22
Section 15 – S-Camshaft and Bearing Removal Procedure ..	23
Section 16 – S-Camshaft and Bearing Installation	24
Section 17 – Brake Adjustment Procedure	26
Section 18 – ABS Sensor Replacement Procedure	27
Section 19 – Wheel Installation Procedure.....	28
Section 20 – Axle Alignment Inspection.....	28
Section 21 – Routine Service Schedule	29
Section 22 – Torque and Lubrication Specifications.....	30
Section 23 – Troubleshooting Chart.....	31

Introduction

This manual provides the necessary information for the maintenance, inspection, and safe operation of the SAF® axle/brake system.

Read this manual before using or servicing this product and keep it in a safe location for future reference. Updates to this manual, which are published as necessary, are available on the internet at www.safholland.us.

Use only SAF-HOLLAND® Original Parts to service the SAF-HOLLAND INTEGRAL™ drum brake axle. A list of technical support locations that supply SAF-HOLLAND Original Parts and an Aftermarket Parts Catalog are available on the internet at www.safholland.us or contact Customer Service at 888-396-6501.

Warranty

Refer to the complete warranty for the country in which the product will be used. A copy of the written warranty is included with the product or available on the internet at www.safholland.com.

Notes, Cautions, and Warnings

Before starting any work on the unit, read and understand all the safety procedures presented in this manual. This manual contains the terms “NOTE”, “IMPORTANT”, “CAUTION”, and “WARNING” followed by important product information. These terms are defined as follows:

NOTE: Includes additional information to enable accurate and easy performance of procedures.

IMPORTANT: Includes additional information that if not followed could lead to hindered product performance.

CAUTION Used without the safety alert symbol, indicates a potentially hazardous situation which, if not avoided, could result in property damage.

⚠ CAUTION Indicates a potentially hazardous situation which, if not avoided, could result in minor or moderate injury.

⚠ WARNING Indicates a potentially hazardous situation which, if not avoided, could result in death or serious injury.

1. Safety Instructions

General and Servicing Safety Instructions

- Read and observe all Warning and Caution hazard alert messages. The alerts provide information that can help prevent serious personal injury, damage to components, or both.

⚠ WARNING Failure to follow the instructions and safety precautions in this manual could result in improper servicing or operation leading to component failure which, if not avoided, could result in death or serious injury.

- All installation should be performed by a properly trained technician using proper/special tools, and safe procedures.

NOTE: In the United States, workshop safety requirements are defined by federal and/or state Occupational Safety and Health Act (OSHA). Equivalent laws could exist in other countries. This manual is written based on the assumption that OSHA or other applicable employee safety regulations are followed by the location where work is performed.

IMPORTANT: Use only SAF-HOLLAND Original Parts to service your SAF-HOLLAND INTEGRAL drum brake axle.

⚠ WARNING Failure to maintain the SAF-HOLLAND INTEGRAL drum brake with SAF-HOLLAND Original Parts can result in brake or wheel bearing failure which, if not avoided, could result in death or serious injury.

- Properly support and secure the vehicle and axles from unexpected movement when servicing the unit.

⚠ WARNING Failure to properly support the vehicle and axles prior to commencing work could create a crush hazard which, if not avoided, could result in death or serious injury.

- If possible, unload the trailer before performing any service procedures.
- After re-positioning the brake chamber, brake adjuster and/or ABS system as instructed in this manual, ALWAYS consult the manufacturer's manual for proper operation.

IMPORTANT: Key components on each axle system including but not limited to suspension, brake adjuster, brake chambers, bearings, hubs, and drums require information supplied by the original manufacturer of the components to ensure proper and safe operation of the axle system.

⚠ WARNING Failure to follow the original manufacturer's instructions regarding spring brake or air pressure control could allow an uncontrolled release of energy which could result in death or serious injury.

- Service both roadside and curbside of an axle. Worn parts should be replaced in sets. Key components on each axle's braking system, such as friction material, rotors and drums will normally wear over time.

Operational and Road Safety Instructions

- The wheel contact surfaces between the wheel and hub **MUST NOT** receive additional paint.

IMPORTANT: The wheel contact surfaces **MUST** be clean, smooth and free from grease.

⚠ WARNING Failure to keep wheel and hub contact surfaces clean and clear of foreign material could allow wheel/hub separations which, if not avoided, could result in death or serious injury.

- Only the wheel and tire sizes approved by the trailer builder can be used.
- Before operating the vehicle, ensure that the maximum permissible axle load is not exceeded and that the load is distributed equally and uniformly.

- Make sure that the brakes are not overheated from continuous operation.

⚠ WARNING Failure to minimize the use of brakes during overheating conditions could result in deterioration of brake efficiency which, if not avoided, could result in death or serious injury.

- The parking brake **MUST NOT** be immediately applied when the brakes are overheated.

CAUTION If the parking brake is immediately applied to the brakes when overheated, the brake drums could be damaged by different stress fields during cooling.

- Observe the operating recommendation of the trailer manufacturer for off-road operation of the installed axles.

IMPORTANT: The definition of OFF-ROAD means driving on non-asphalt/non-concrete routes, such as gravel roads, agricultural and forestry tracks, on construction sites and in gravel pits.

IMPORTANT: Off-road operation of axles beyond the approved application design could result in damage and impair suspension system performance.

- SAF axles require routine service, inspection and maintenance to maintain optimum performance, operational and road safety, and to recognize natural wear and defects before they become serious. Please refer to the Service Manual for Drum Brake Axles XL-TA1000060M-en-US which can be found at www.safholland.us or contact our customer service group at 888-396-6501.

2. Model Identification

The Drum Brake Axle Serial Tag is located near the center of the axle tube (**Figure 1**).

3. Identification Tag

The sample tag illustrated will help interpret the information on the SAF-HOLLAND USA®, Inc. serial number tag. The model number, axle body part number, axle beam rating, and serial number are listed on the tag (**Figure 2**).

Record the tag numbers below for future quick reference.

Axle Body Part Number _____

Model Number _____

Axle Beam Rating _____

Serial Number _____

Figure 1

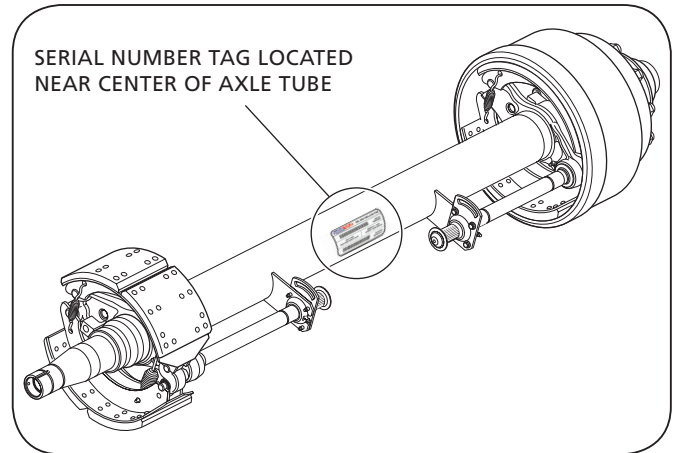
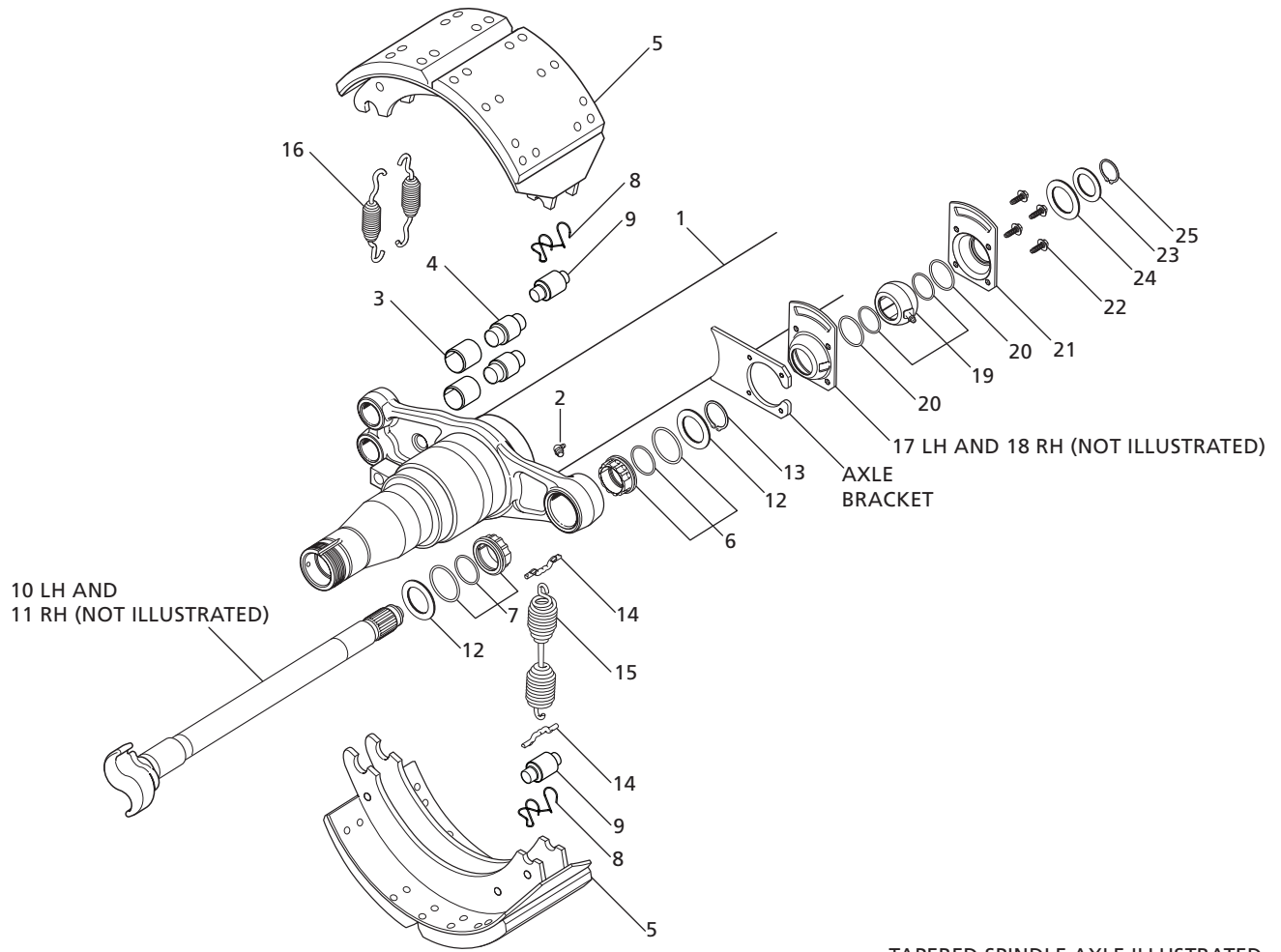

Figure 2





TAPERED SPINDLE AXLE ILLUSTRATED

BRAKE COMPONENTS		
ITEM	DESCRIPTION	QTY
1	Axle Body Assembly	1
2	Fitting, Lubrication	2
3	Bushing, Anchor Pin	4
4	Pin, Anchor	4
5	Brake Shoe Assembly	4
6	Bearing Assembly, S-Cam-Spider Inboard	2
7	Bearing Assembly, S-Cam-Spider Outboard	2
8	Retainer, Roller	4
9	Roller, Brake Shoe	4
10	S-Camshaft, Left-Hand	1
11	S-Camshaft, Right-Hand (not shown)	1
12	Washer, S-Cam Bearing-Outboard	4
13	Retainer Ring	2

BRAKE COMPONENTS		
ITEM	DESCRIPTION	QTY
14	Return Spring Pin	4
15	Spring, Return-Hub/Drum	2
16	Spring, Anchor Pin	4
17	Housing, S-Cam Bearing, Left-Hand Slotted	1
18	Housing, S-Cam Bearing, Right-Hand Slotted	1
19	Bearing Assembly S-Camshaft	2
20	O-Ring, S-Camshaft Bearing Seal-Inboard	4
21	Housing, S-Cam Bearing	2
22	Screw, Thread Rolling Tapping	8
23	Washer, Shaft End	2
24	Washer, Shaft End	2
25	Retaining Ring	2

NOTE: Refer to Drum Brake Axle Parts Manual XL-TA10058PM-en-US for axle component and service kit part numbers.

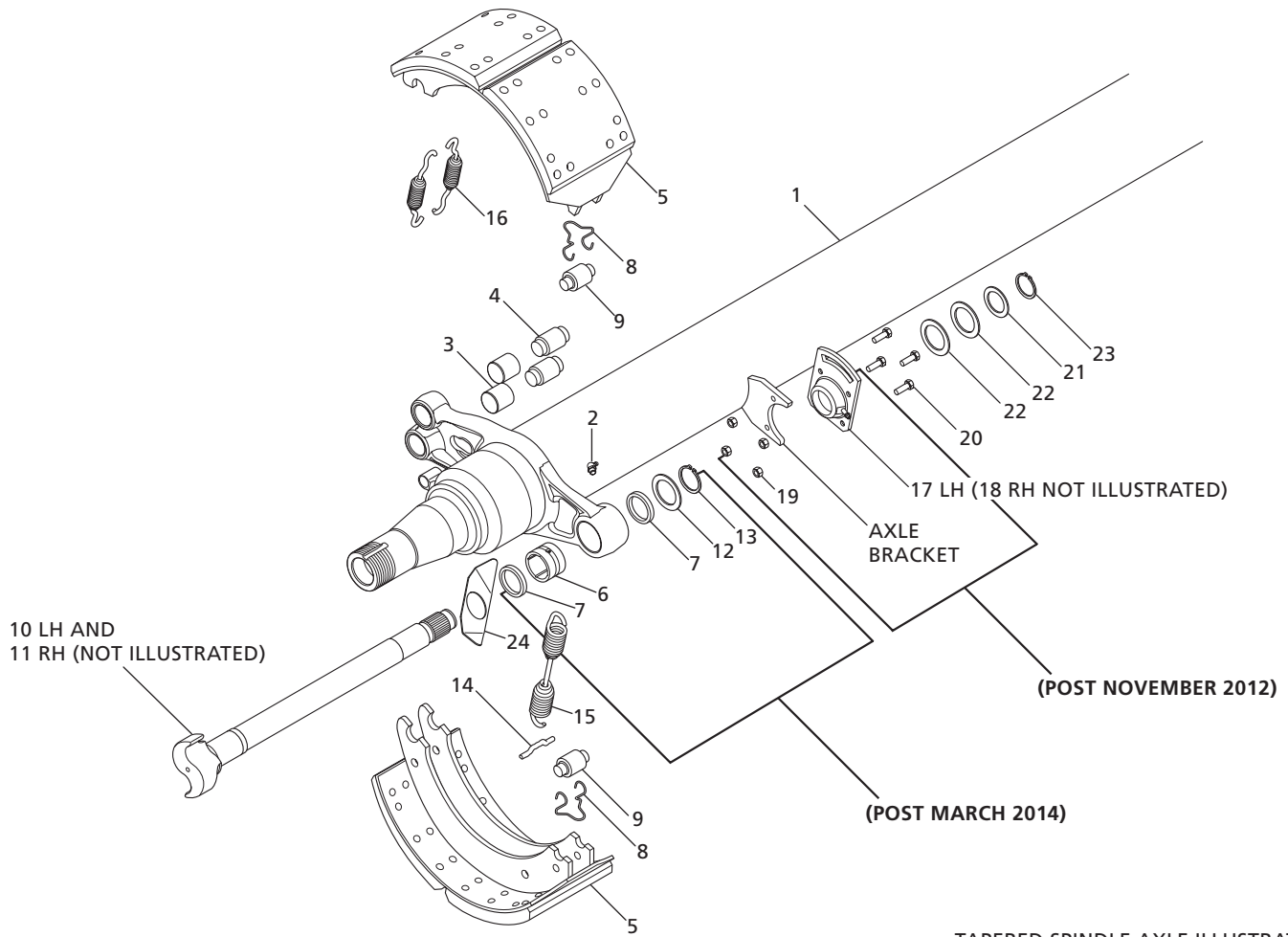

TAPERED SPINDLE AXLE ILLUSTRATED

BRAKE COMPONENTS		
ITEM	DESCRIPTION	QTY
1	Axle Body Assembly	1
2	Fitting, Lubrication	2
3	Bushing, Anchor Pin	4
4	Pin, Anchor	4
5	Brake Shoe Assembly	4
6	Bushing, Cam Bearing	2
7	Cam Seal, Spider	4
8	Retainer, Cam Roller	4
9	Roller, Brake Shoe	4
10	S-Camshaft, Left-Hand	1
11	S-Camshaft, Right-Hand (not shown)	1
12	Washer, S-Cam Bearing-Outboard	2

BRAKE COMPONENTS		
ITEM	DESCRIPTION	QTY
13	Retainer Ring	2
14	Return Spring Pin	4
15	Spring, Return-Hub/Drum	2
16	Spring, Anchor Pin	4
17	Cam Bearing Kit - Left-Hand	1
18	Cam Bearing Kit - Right-Hand (not shown)	1
19	Nut, Lock	8
20	Bolt, Hex Head Cap	8
21	Washer, Shaft End	2
22	Washer, Shaft End	4
23	Retaining Ring	2
24	Guide PLate, Brake Roller Shoe	2

NOTE: Refer to Drum Brake Axle Parts Manual XL-TA10058PM-en-US for axle component and service kit part numbers.

4. Hubs, Bearings and Seal Removal

NOTE: Before starting any axle/brake service procedures, park the vehicle on a level surface. Block the wheels to prevent the vehicle from moving. Support the vehicle and axle(s) with safety stands. DO NOT work under a vehicle supported only by jacks. Jacks can slip or fall over. Serious personal injury and damage to components can result.

⚠ WARNING Failure to properly support the vehicle and axles prior to commencing work could create a crush hazard which, if not avoided, could result in death or serious injury.

1. Release the trailer brakes and cage the spring brakes according to the spring brake manufacturer's instructions. Remove the tire and wheel assembly to access the hub and drum.
2. Remove the drum from the hub using a support device such as a drum dolly (**Figure 3**).

⚠ CAUTION Failure to support weight during installation or removal of the brake drum could create a crush hazard which, if not avoided, could result in minor to moderate injury.

NOTE: It is necessary to retract the brake shoes in accordance with the brake adjuster's manufacturer manual to allow the brake drum to clear the brake shoes during brake drum removal.

3. Remove the hub cap and gasket by removing six (6) bolts (**Figure 4**).

NOTE: Be prepared to collect lubrication fluid when removing the hub cap.

Figure 3

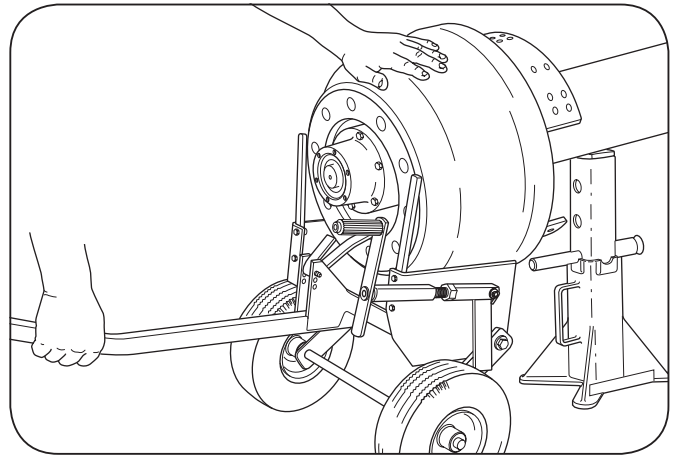
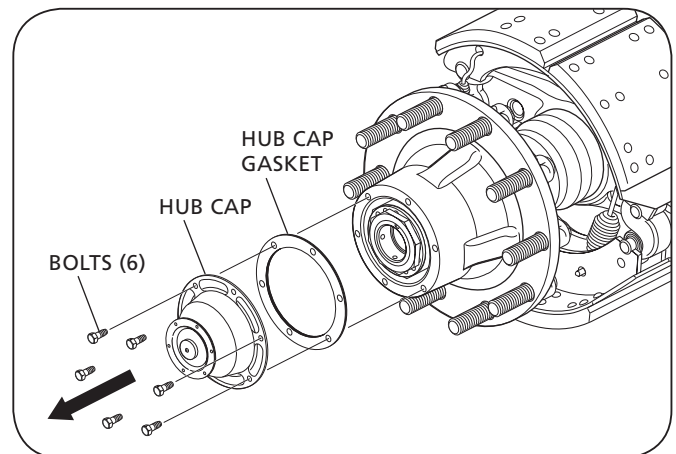

Figure 4



4. Remove the set screws (**Figure 5**).
5. Remove the axle nut from the spindle using a wrench with the axle nut socket. If the unit is equipped with a Pro-Torq® spindle nut, remove the nut and skip Step 5 (**Figure 6**).
6. Release the axle washer and the inner axle nut from the spindle (**Figure 6**).
7. Remove the outer hub bearing from the spindle (**Figure 6**).

NOTE: With the axle nut, washer, and inner nut removed, it is possible to access the outer bearing.

CAUTION DO NOT hit steel parts with a steel hammer as parts could break, sending flying steel fragments in any direction creating a hazard which, if not avoided, could result in minor to moderate injury.

8. Grasp the hub assembly with both hands and pull the hub assembly off the axle spindle (**Figure 7**).

NOTE: Depending on the type of hub seal, the hub seal and inner bearing could remain on spindle or come off with hub assembly.

Figure 5

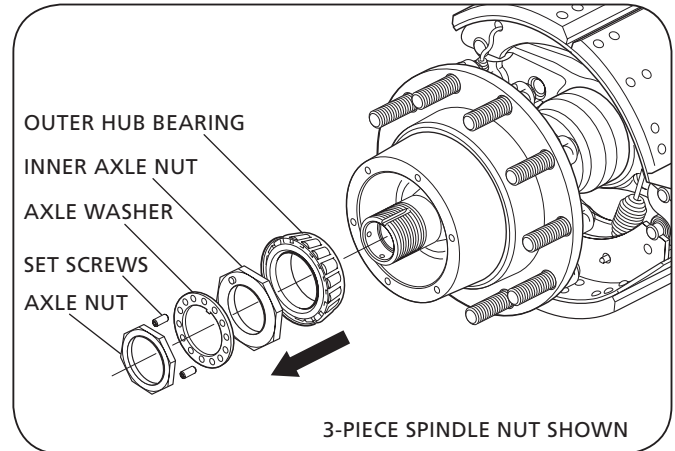

Figure 6

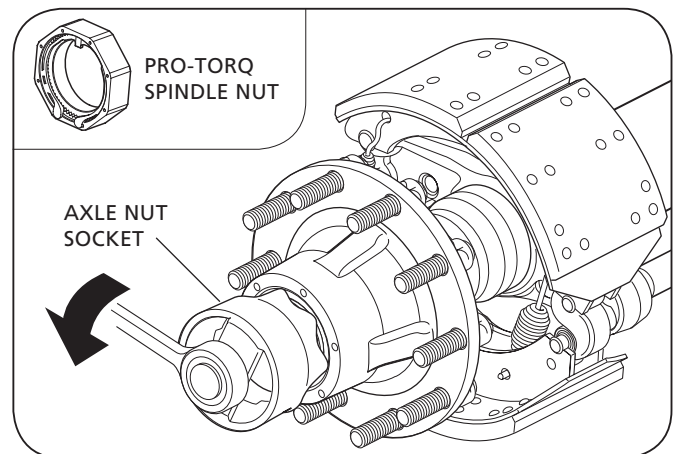
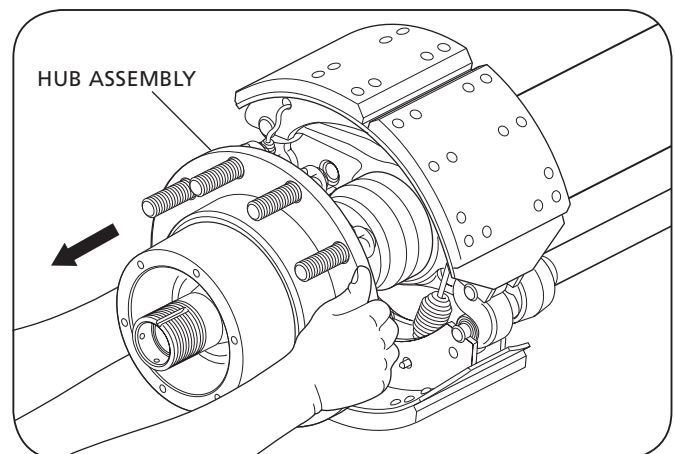

Figure 7



9. Remove the inner hub bearing from the spindle or from the inside of the hub (**Figure 8**).
10. Remove the hub seal from the hub bore using a pry bar. A spindle mount hub seal can be driven off the spindle by striking the ring from the back side or prying off with a crow's foot bar. Discard the used hub seal and use a new hub seal during re-assembly being careful not to gouge the spindle shoulder (**Figure 8**).

CAUTION DO NOT use a chisel to cut the seal. The shoulder can be damaged, resulting in a leak which could lead to wheel end and/or brake failure.

5. Bearing Inspection

CAUTION Thoroughly clean the bearings. DO NOT mix a synthetic base grease or oil with an organic/mineral base lubricant.

CAUTION DO NOT spin dry the hub bearings with compressed air. Bearing damage could result.

1. After removing the hub assembly, clean excess grease from the bearings.

IMPORTANT: A bearing which has been removed from a vehicle should be cleaned with solvent. When cleaning DO NOT use steam or water which will cause the bearings to rust.

IMPORTANT: Bearings that are rusted, flaked, pitted, or have damaged cages should be replaced. It is recommended to replace all questionable bearings and ALWAYS replace the cup and cone as a matched set. NEVER re-assemble a tapered roller bearing in a damaged or worn housing or on damaged or worn spindles. Housings or spindles should be replaced and NOT re-machined if the bearing journal is worn.

Figure 8

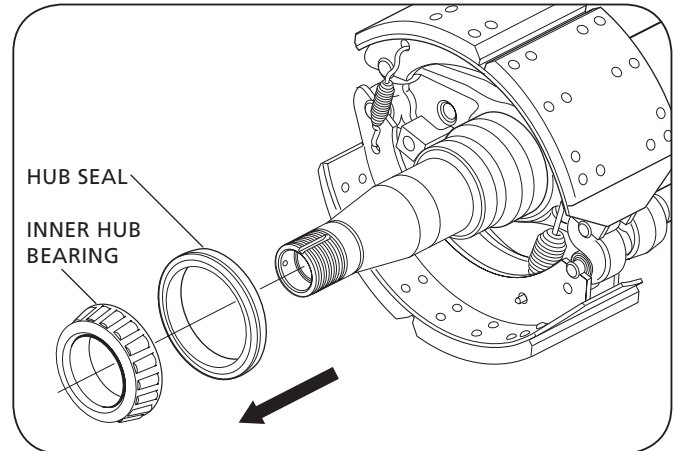

6. Hubs, Bearings and Seal Installation

6.1 Spindle mounted Hub Seal Installation instructions (Refer to 6.2 for hub mounted Hub Seal instructions)

1. Before installing the hub seal on the axle spindle, inspect the machined spindle seal surface for nicks, scratches, burrs or marks. If needed, use crocus cloth or emery cloth to repair any damaged areas.
2. Clean the threads and the keyway thoroughly with a wire brush to avoid false bearing adjustments and to avoid introduction of contaminants into the lubricant cavity.
3. Thoroughly clean the spindle and spindle threads of rust, dirt, grease or any other contaminants that could damage the hub seal and cause it to leak.

CAUTION

NEVER install a spindle mounted hub seal in the hub and then force it onto the axle spindle by tightening the axle nut. Damage to the seal will result.

4. The seal assembly should be placed on the spindle so the words "Oil Bearing Side" are exposed to the oil (**Figure 9**).
5. Drive the hub seal into place using the seal installation tool and hammer. Rotate the hub seal installation tool in 1/4-turn intervals with every hammer tap until the seal is properly seated with the metal face of the seal flush with the inner shoulder of the axle spindle (**Figure 10**).
6. Apply a thin coat of oil to the O.D. of the seal.
7. Prepare the hub. Remove the old lube and thoroughly clean the hub cavity and hub bore. Inspect the inner hub bore for roughness. If needed, use an emery cloth to remove any burrs or old bore sealant.

Figure 9

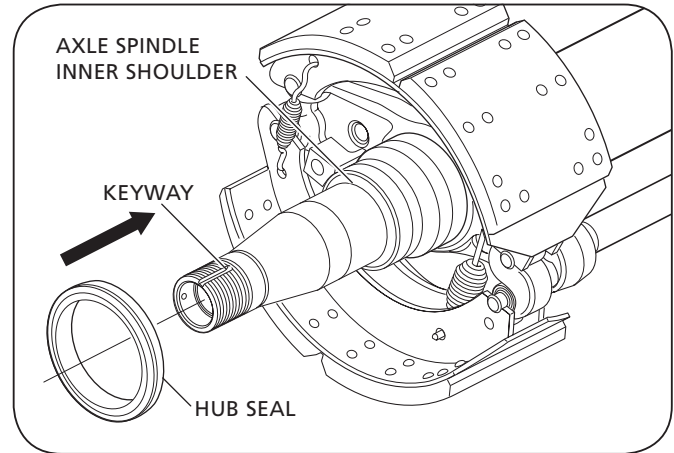
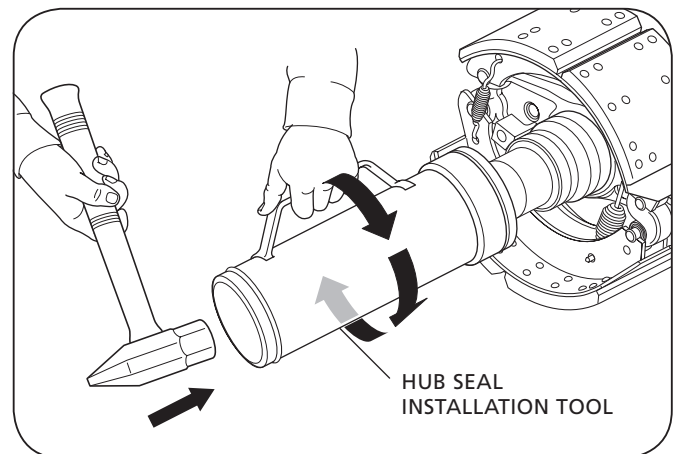

Figure 10



- Install the inner and outer bearing cups into hub (**Figure 11**).
- Pre-lube the inner bearing with the lubricant that is being retained and place it into the hub.

CAUTION Failure to lubricate the bearing correctly and maintain proper lubrication could result in bearing damage.

NOTE: If using grease and not oil for hub lubrication, the inner and outer bearing, and the hub cavity **MUST** be pre-packed with grease before installation. Lubricate the wheel end components with grease specified in the lubrication table in Section 22.

- Push the hub onto the spindle until it contacts the seal. Pre-lube the outer bearing with the lubricant that is being retained and place it into the hub.

CAUTION Support the hub against the spindle inner shoulder until the outer bearing and adjusting nut are installed. **DO NOT** ram the hub into the bearing shoulder, which, if not avoided, could damage the hub seal.

6.2 Hub Mounted Hub Seal Installation Instructions

- Remove all the burrs from the hub bore and the spindle. Thoroughly clean the hub cavity and spindle.
- Place the hub on a smooth, hard surface in a horizontal position. Pre-lube the inner bearing with the lubricant that is being retained and place it into the hub bearing cup (**Figure 12**).

NOTE: When using grease, pre-pack the inner bearing before placement into the hub.

- With the correct head on the hub seal installation tool, place the hub seal on the installation tool, so that the words "Lube Side" face the inner bearing. Place the tool (with the seal correctly mounted in the tool head) into the hub bore. Use a three to five pound hammer to drive against the end of the tool. Drive the seal into the bore until complete bottoming is assured (**Figure 13**). Remove the Installation Tool and apply a thin layer of lubricant on the I.D. surface of the seal. Ensure the inner bearing rotates freely. Install a new seal if the seal is crooked or damaged or after installation.

NOTE: **DO NOT** apply lubricant to the O.D. of the seal.

Figure 11

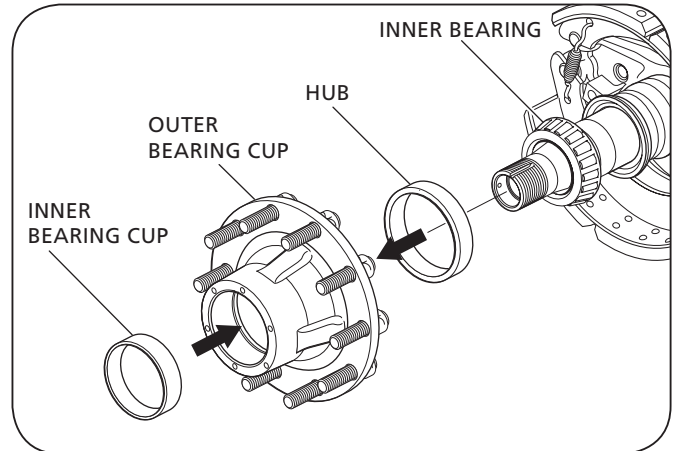

Figure 12

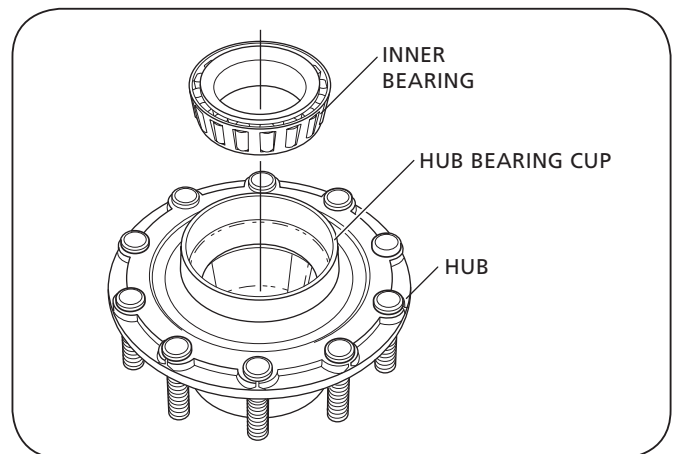
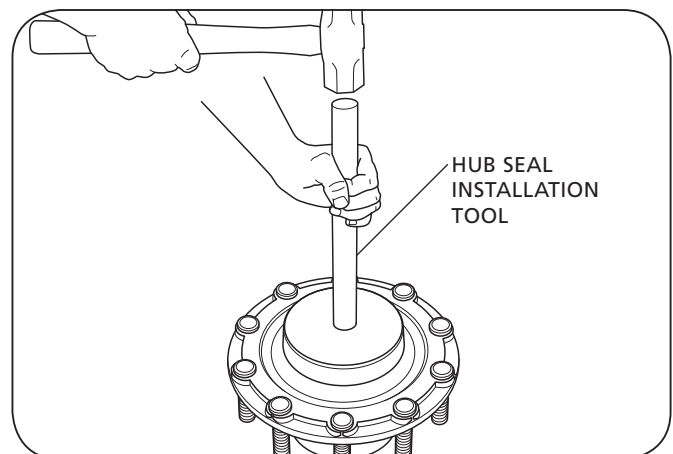

Figure 13



4. Align the hub bore to the center of spindle with mechanical supports. Gently push the hub assembly onto the spindle until the seal is seated against the bearing shoulder. Rotate the hub and lightly strike to ensure that the seal is properly seated against the bearing shoulder.
5. Pre-lube the outer bearing with the lubricant that is being retained and place into the hub.

NOTE: When using grease, pre-pack the hub cavity. The grease fill amount should be to a three (3) o'clock and nine (9) o'clock level. This is to ensure a 50% hub cavity fill. Use a template to hold the grease in place while filling the hub cavity (**Figure 14**).

7. Hub Bearing Adjustment

7.1 Hub Bearing Adjustment Using 3-Piece Axle Nut

1. Install the bearing inner-axle adjustment nut finger tight against the outer bearing (**Figure 15**).
2. While rotating the hub assembly, tighten the inner axle adjustment nut to 200 ft.-lbs. (271 N•m).
3. Back off the inner axle adjustment nut one full turn and then re-torque the nut to 50 ft.-lbs. (68 N•m) while rotating the hub assembly.
4. Back off the inner axle nut approximately 1/4 turn and install the axle lock washer (**Figure 16**). DO NOT include socket backlash in the 1/4 turn.
5. Install the lock washer. If the hole in the washer is NOT aligned with the pin on the inner nut, turn the washer around and re-install. If the pin and hole are still NOT aligned, slightly adjust parts as needed.
6. Install the outer axle nut finger tight against the axle lock washer (**Figure 16**).
7. Tighten the outer axle nut to 200-300 ft.-lbs. (271-407 N•m).

Figure 14

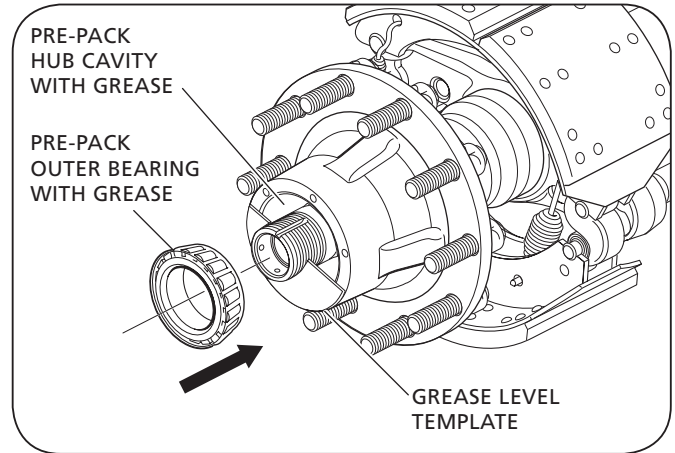

Figure 15

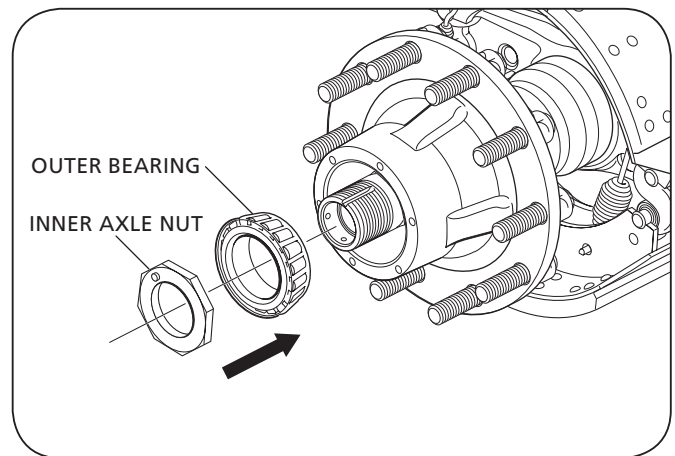
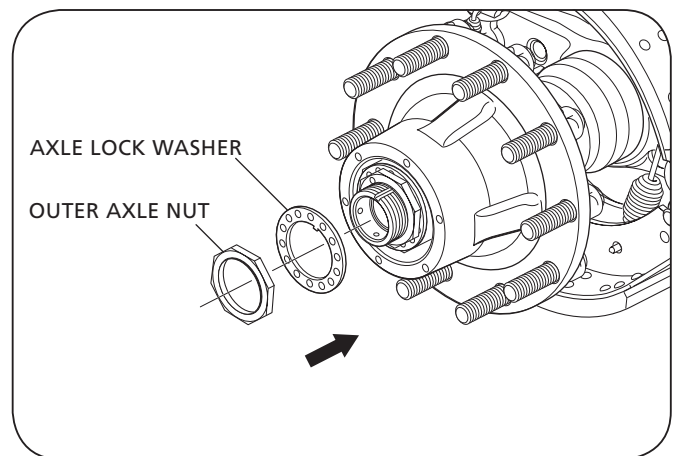
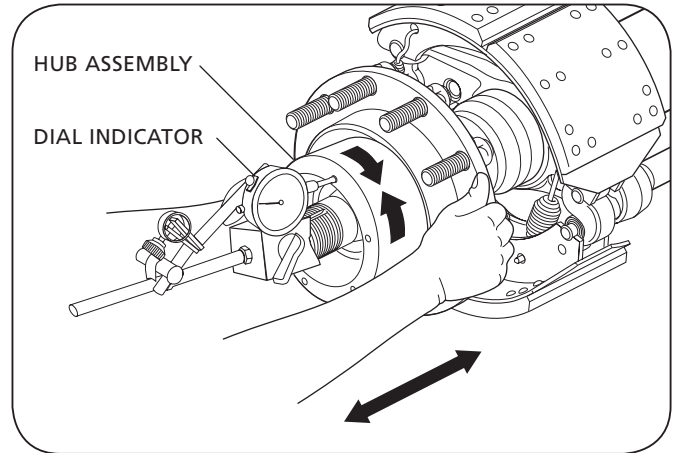

Figure 16



8. Check the wheel bearing end play as follows:
 - a. Attach the magnetic base of a dial indicator to the spindle. Touch the dial indicator stem to the hubcap gasket face (**Figure 17**).
 - b. Reading Number One – Slightly rotate the wheel-end in both directions while pushing inward until the dial indicator does not change. Set the dial indicator to zero (**Figure 17**).
 - c. Reading Number Two – Slightly rotate the hub in both directions while pulling outward until the dial indicator does not change (**Figure 17**).
 - d. End play is the difference between reading number one and reading number two.

Figure 17



IMPORTANT: Final adjustment should allow the wheel to rotate freely with 0.001" to 0.005" (0.025 mm to 0.0127 mm) end play. If the end play is NOT within specification, re-adjustment is required.

⚠ WARNING Failure to maintain proper hub bearing adjustment could allow bearing failure and wheel-end separation which, if not avoided, could result in death or serious injury.

NOTE: If the wheel bearing end play needs adjustment, remove the outer nut and the lock washer. Tighten or loosen the inner nut as needed. Return to Step 6.

9. Install the set screw into an accessible threaded hole in the lock washer. Set screw **MUST** contact the inner adjusting nut. Tighten to 16-20 in.-lbs. (1.8-2.2 N•m) (**Figure 19**).

Figure 18

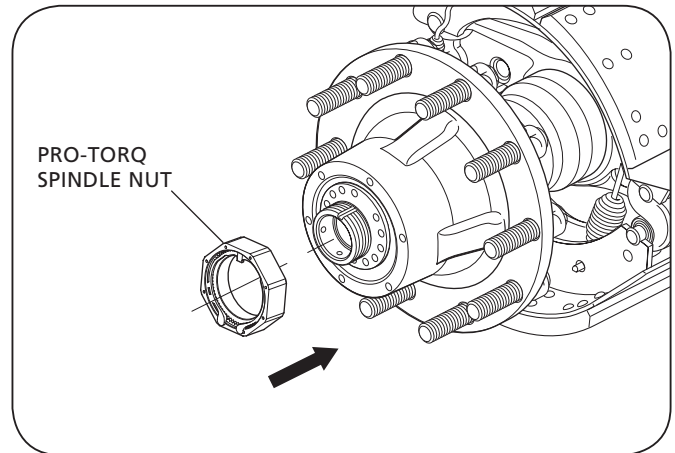

7.2. Hub Bearing Adjustment Using Pro-Torq Axle Nut

The unit could be equipped with a Pro-Torq spindle nut (**Figure 18**). Refer to Stemco® "Pro-Torq Installation Instructions" (Part No. 09-571-006) which can be found at www.stemco.com for more information.

Figure 19

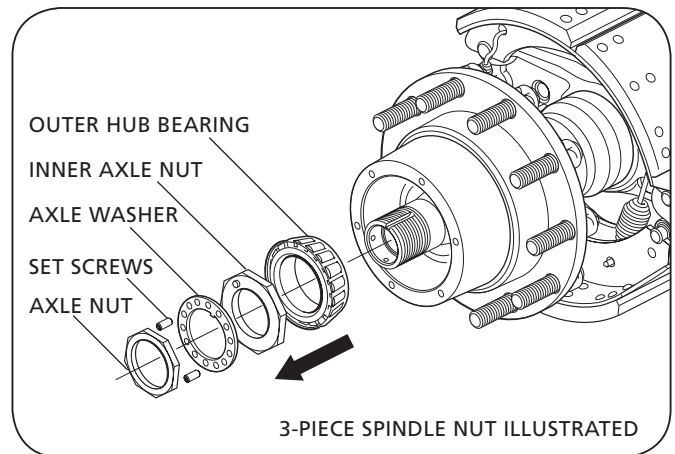

8. Hub Cap Installation

1. Install the hub cap assembly, making sure the hub cap gasket is in place (**Figure 20**).

CAUTION

When installing the hub cap, make sure the hub cap gasket is not bent or damaged.

CAUTION

DO NOT over torque. This can crush the hub cap gasket and cause a leak.

2. Install the six (6) bolts to secure the hub cap assembly (**Figure 18**, page 14). Tighten the bolts to 12-16 ft.-lbs. (16-21 N•m).

9. Filling Hub With Lubricant (Oil Based)

IMPORTANT: DO NOT mix oil lubricant with grease lubricant. If the bearing assembly has been lubricated with grease DO NOT add oil.

WARNING

Failure to correctly lubricate the bearings could damage the bearings which, if not avoided, could result in death or serious injury.

1. Remove the plug and fill the hub to the FULL mark with the specified lubricant (oil), through the hole in the hub cap (**Figure 21**).
2. Allow the oil to flow through the bearings and level off.
3. Insert the plug into the hole in the hub cap (**Figure 22**).

IMPORTANT: Axles equipped with a centralized tire inflation system MUST use a vented hub cap.

Figure 20

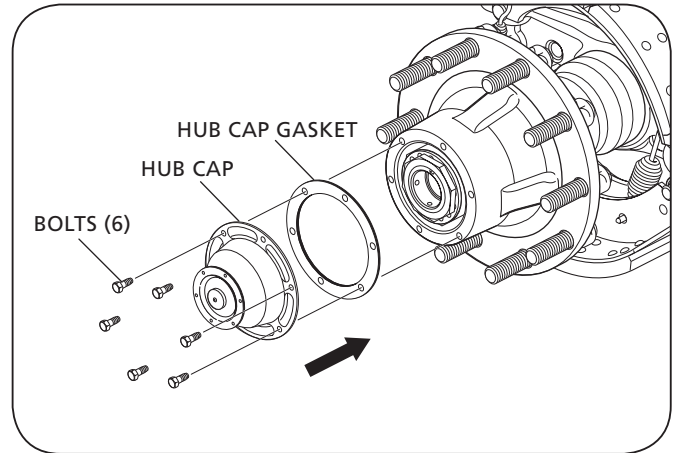

Figure 21

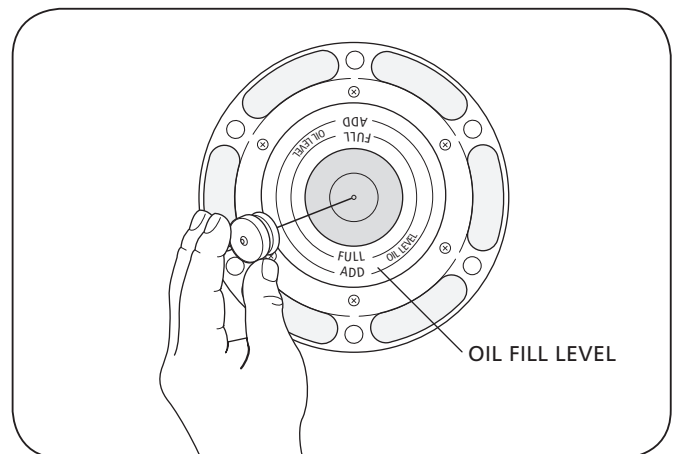
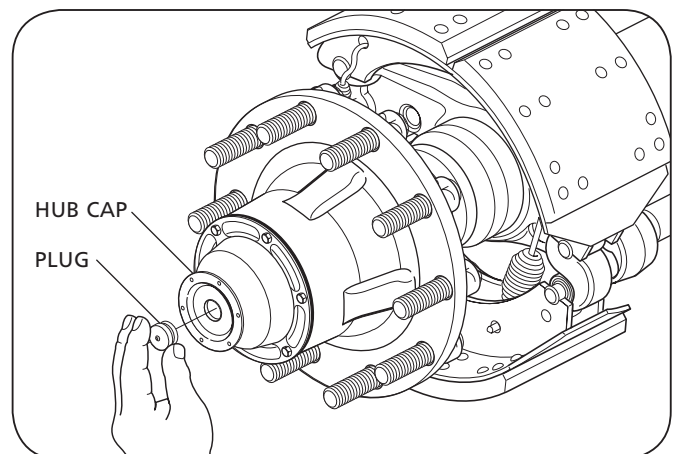

Figure 22



4. Re-install the drum on the hub using a support device such as a drum dolly jack (**Figure 23**).

CAUTION Failure to support weight during installation or removal of the brake drum could create a crush hazard which, if not avoided, could result in minor to moderate injury.

CAUTION Failure to uncage the spring brakes in accordance with manufacturer's instructions after servicing is complete will prohibit proper brake function, which, could result in uneven brake system component wear.

10. Retracting the Brake Shoes or Brake Adjuster Control Arm(s)

IMPORTANT: Refer to the brake adjuster's manufacturer's procedures for proper adjustment of the brake adjusters.

WARNING Failure to operate with proper brake adjuster position could render brakes inoperable which, if not avoided, could result in death or serious injury.

NOTE: When servicing the brakes, in some instances it could be necessary to fully retract the brake shoes in order to remove the brake drum.

NOTE: When removing the S-Camshaft, it is necessary to retract the brake adjuster control arm(s) from the clevis so the brake adjuster can be removed from the S-Cam shaft.

In both of the notes above, the brake shoes or the brake adjuster control arm(s) are retracted by turning the adjusting nut manually on the automatic brake adjuster.

Figure 23

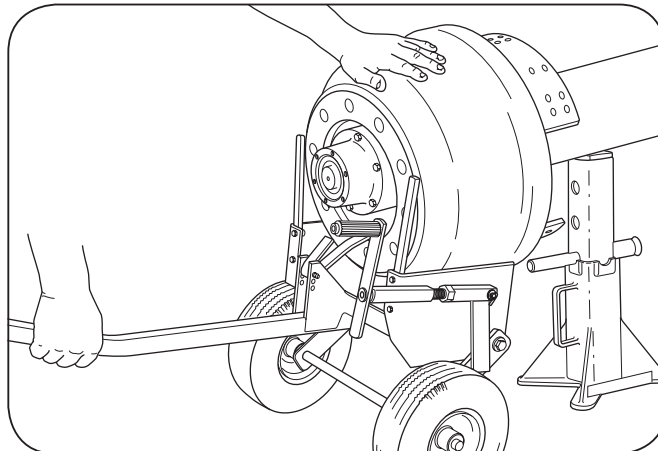

11. Brake Shoe Removal

NOTE: Before starting any axle/brake service procedures, park the vehicle on a level surface. Block the wheels to prevent the vehicle from moving. Support the vehicle and axle(s) with safety stands. DO NOT work under a vehicle supported only by jacks. Jacks can slip or fall over. Serious personal injury and damage to components can result.

⚠ WARNING Failure to properly support the vehicle and axles prior to commencing work could create a crush hazard which, if not avoided, could result in death or serious injury.

1. Release the trailer brakes and cage the spring brakes according to the spring brake manufacturer's instructions. Remove the tire and wheel assembly to access the hub and drum.
2. Remove the drum from the hub using a support device such as a drum dolly (**Figure 24**).

⚠ CAUTION Failure to support weight during installation or removal of brake drum could create a crush hazard which, if not avoided, could result in minor to moderate injury.

NOTE: It is necessary to retract the brake shoes in accordance with the brake adjuster's manufacturer's manual to allow the brake drum to clear the brake shoes during the brake drum removal.

3. Using the brake spring pliers, unhook both the brake retaining springs from the brake shoes (**Figure 25**).
4. Press down on the lower brake shoe to disengage it from the anchor pin. Move the lower shoe to the side of the anchor bracket and lift the upper and lower shoes (still connected by brake return spring) from the anchor pins (**Figure 26**).

IMPORTANT: The brake return spring, brake shoe rollers and roller retaining clips will remain on the brake shoes during this procedure.

Figure 24

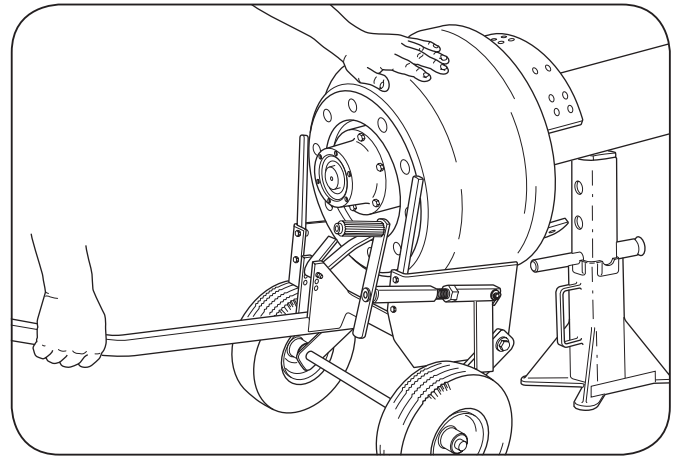

Figure 25

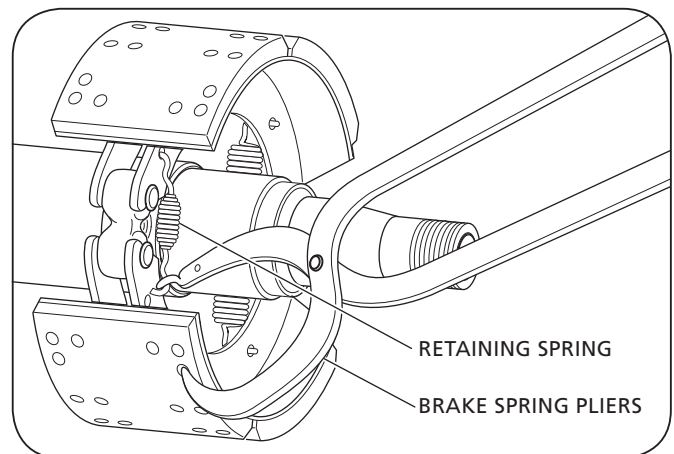
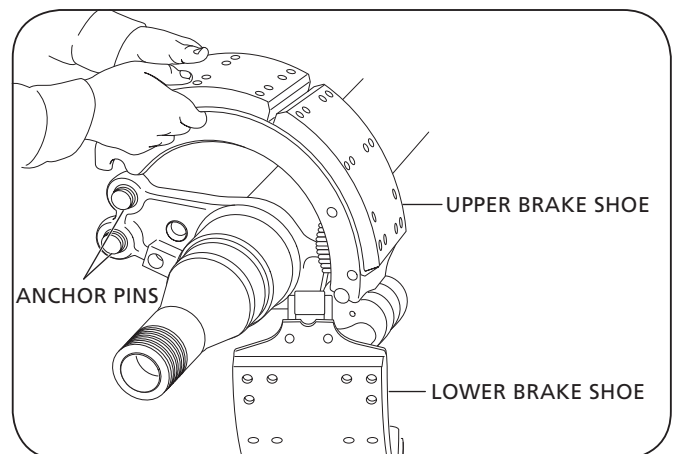

Figure 26



5. Discard the used brake hardware.

IMPORTANT: Brake hardware such as brake rollers, roller retaining clips and brake return springs experience fatigue during their normal lifespan and could not have the same performance characteristics as new components. Since most of these brake components are supplied new with the brake overhaul kit, the existing components should NOT be re-used.

6. With the brake shoes off, inspect the S-Camshaft and S-Camshaft bushings for wear. Verify that the S-Cam-to-bushing radial free play is within specification by using a dial indicator and moving the S-Camshaft back and forth (**Figure 27**). Rotate the S-Camshaft in all directions when checking for radial free play.

NOTE: Use a dial indicator to verify that S-Cam-to-bushing free play is 0.030" (0.76 mm) or less.

- If radial free play is less than 0.030" (0.76 mm): DO NOT replace the bushings and the seals.
- If radial free play is more than 0.030" (0.76 mm): Replace the bushings and the seals.

7. Inspect the brake shoes and components for wear:
 - h. Inspect the spider for expanded anchor pin holes and for cracks. Brake spiders cannot be repaired and MUST be replaced with new axle assembly.
 - i. Inspect the S-Camshaft bracket for broken welds, cracks and correct alignment. Replace the damaged brackets.
 - j. Inspect the anchor pins for corrosion and wear. Replace worn or damaged anchor pins.

NOTE: Follow the brake shoe manufacturer specifications for minimum brake shoe thickness and maximum brake drum inner diameter. A general guideline for replacing brake shoes is when the lining thickness is 1/4" (6 mm) or less, or when the lining rivets have begun to contact the drum (**Figure 28**).

CAUTION

Failure to replace the brake shoes that are excessively worn could result in damage to brake drum or other components.

- k. Inspect the brake shoes for wear, expanded rivet holes, broken welds and correct alignment. Replace the shoes as a set with any of the above conditions.

Figure 27

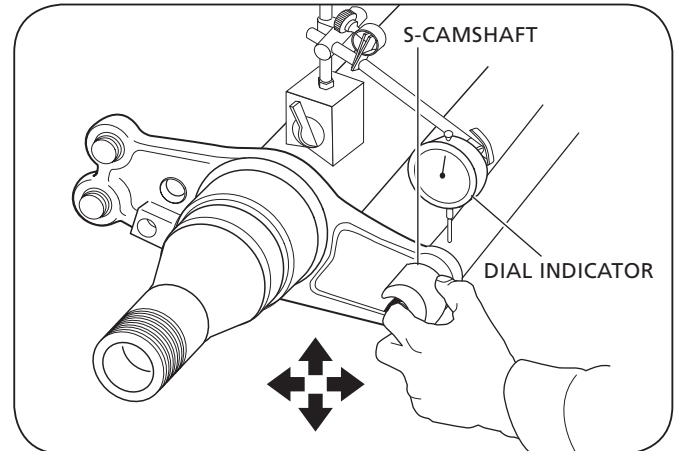
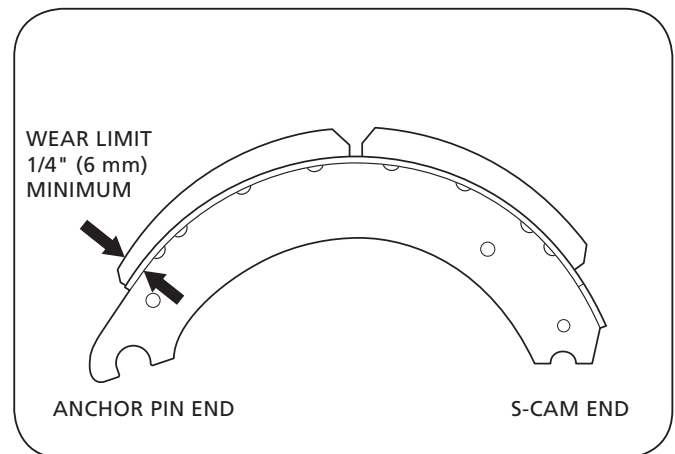

Figure 28



8. Inspect the brake drums for wear.

⚠ WARNING DO NOT operate the vehicle with the brake drum worn or machined beyond the discard dimension indicated by the drum manufacturer. The brake system may not operate correctly. Damage to components, death or serious injury, could result.

⚠ CAUTION Replace the brake drum if it is out-of-round. DO NOT turn or re-bore a brake drum beyond manufacturers recommendations. Doing so could decrease the strength and capacity of the drum which, if not avoided, could result in brake component damage.

- a. Inspect the brake drums for cracks, severe heat checking, heat spotting, scoring, pitting and distortion. Replace the drums as required.
- b. Measure the inside diameter of the drum in several locations with a drum caliper or internal micrometer (*Figure 29*).
- c. If brake drum is excessively worn or out of round replace the brake drum.

⚠ CAUTION Failure to replace an out of round brake drum could result in damage to the brake drum or other components.

12. Brake Shoe Installation

1. Install the brake shoe roller into the roller retainer (*Figure 30*).
2. Install the roller and roller retainer into the brake shoe ribs (*Figure 30*).
3. Coat anchor pins (ends only) completely with lubricant (Never-Seez®) and install (if removed) in the brake spider (*Figure 31*).

Figure 29

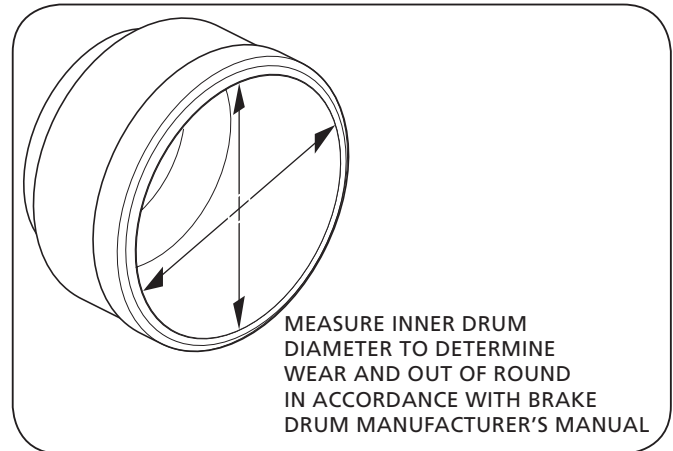

Figure 30

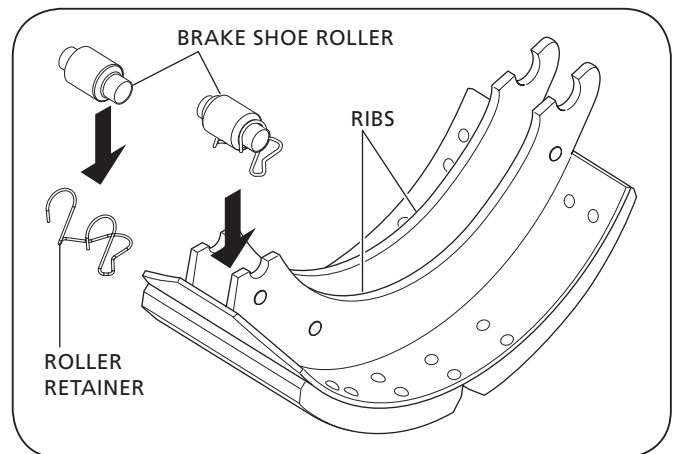
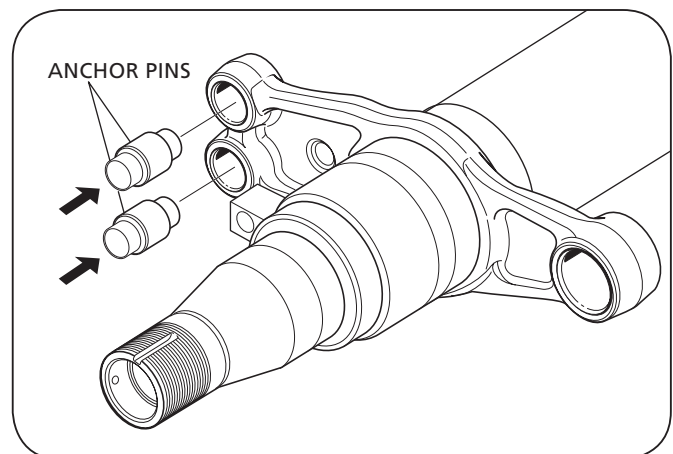

Figure 31



4. Install the return spring pin into the brake shoe ribs (**Figure 32**).
5. Connect the hub/drum return spring to the upper and lower brake shoes (**Figure 33**).
6. Position the roller of the upper brake shoe up against the S-Cam, then place the other end of the shoe against the anchor pin (**Figure 34**).

CAUTION Failure to control spring pressure during the brake shoe installation could create a pinch hazard which, if not avoided, could result in minor to moderate injury.

Figure 32

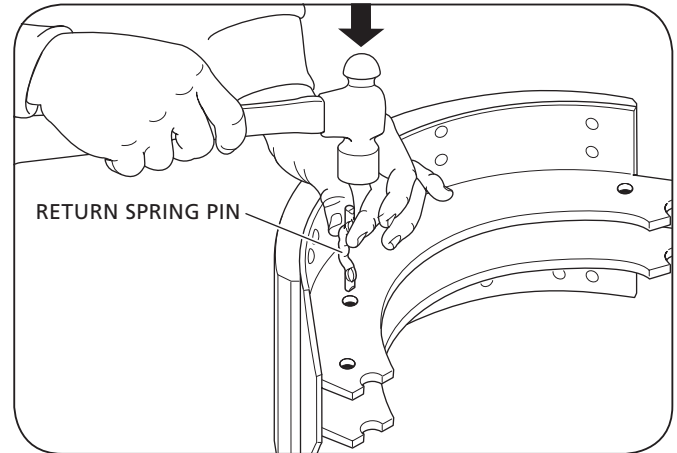

Figure 33

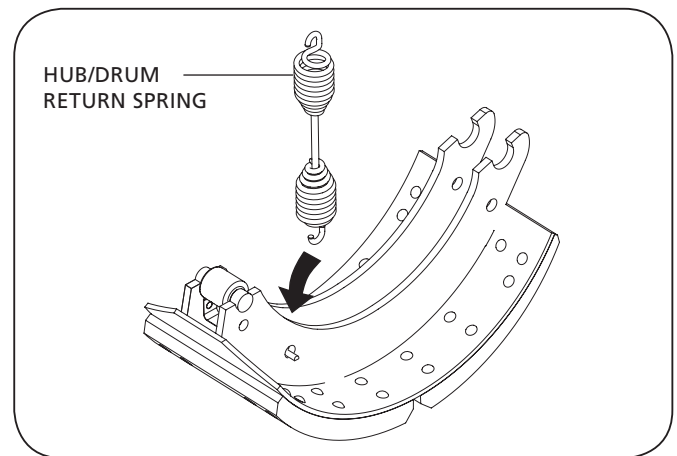
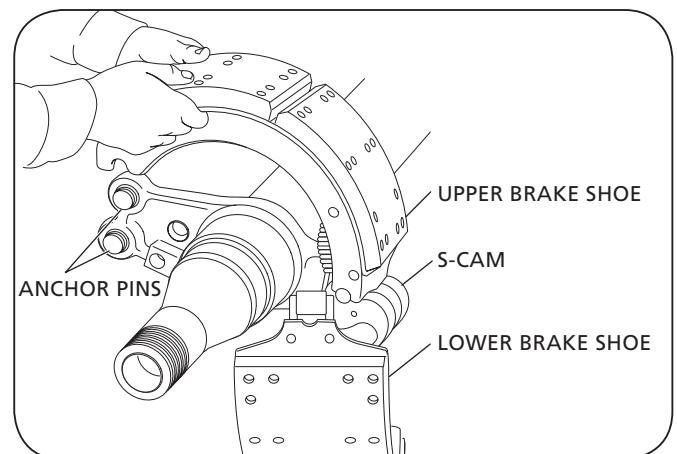

Figure 34



7. Position the roller of the lower brake shoe up against the S-Cam, then place the other end of the shoe against the anchor pin (**Figure 35**).
8. Install the two (2) brake anchor pin springs using the anchor pin pliers (**Figure 36**).
9. Make sure the brake linings are clean.
10. Re-install the drum using a support device such as a drum dolly jack (**Figure 37**).

CAUTION Failure to support weight during the installation or removal of the brake drum could create a crush hazard which, if not avoided, could result in minor to moderate injury.

11. Adjust the brakes as described in Section 17.

Figure 35

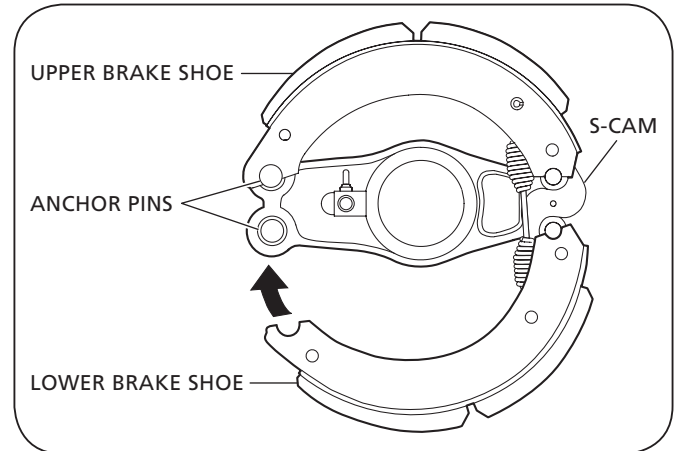

Figure 36

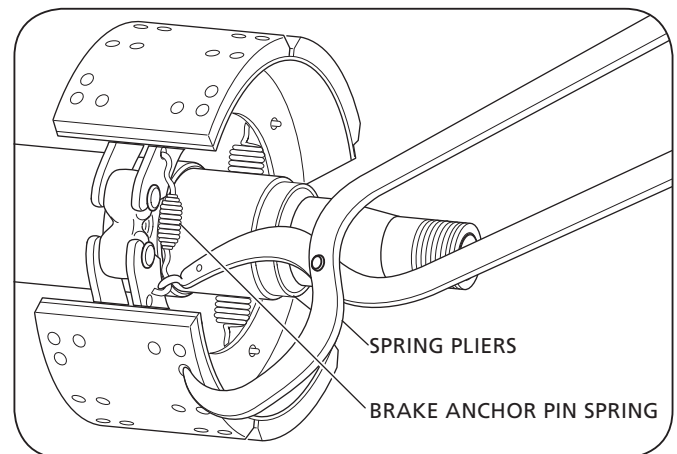
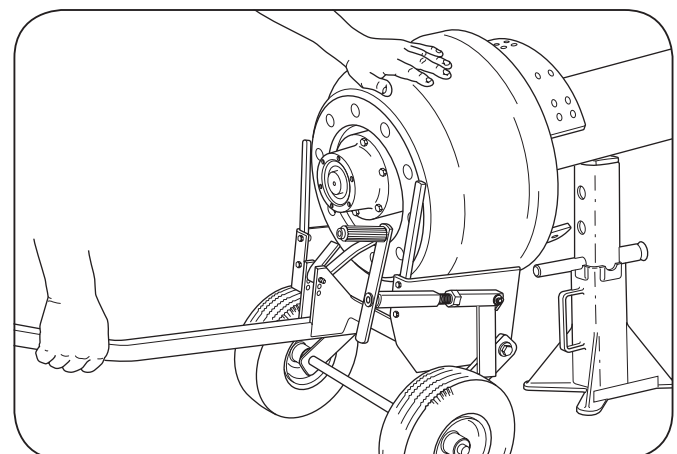

Figure 37



13. Brake Adjuster Removal

NOTE: Maintenance procedures in this section require re-positioning of the brake adjuster. Consult the manufacturer's manual for procedures to properly operate the brake adjusters.

1. Remove the cotter pins that secure the brake adjuster/ brake chamber clevis pins (**Figure 38**). Remove the clevis pins.
2. Remove the retaining ring and washer that secure the brake adjuster to the S-Camshaft (**Figure 39**).
3. Remove the self-adjusting brake adjuster from the spline end of the brake S-Camshaft.
4. Rotate the adjusting mechanism to back the brake adjuster out of the clevis in accordance with the brake adjusters manual.

14. Brake Adjuster Installation

1. Apply an even coat of anti-seize compound to splined surface of the S-Camshaft.
2. Position the spacing washers on both sides of the brake adjuster, then install the brake adjuster onto the S-Camshaft spline and secure the brake adjuster on the S-Camshaft by assembling the retaining ring (**Figure 40**).
3. Align the brake adjuster to the clevis and pin together using the clevis pins and the cotter pins (**Figure 38**).
4. Apply service and the spring brake several times. Final brake adjustment is required to ensure proper initial brake operation. The brake adjuster will then seek the proper working stroke during normal operating conditions. Refer to the brake adjuster and brake chamber manufacturers' procedures for proper adjustment.

Figure 38

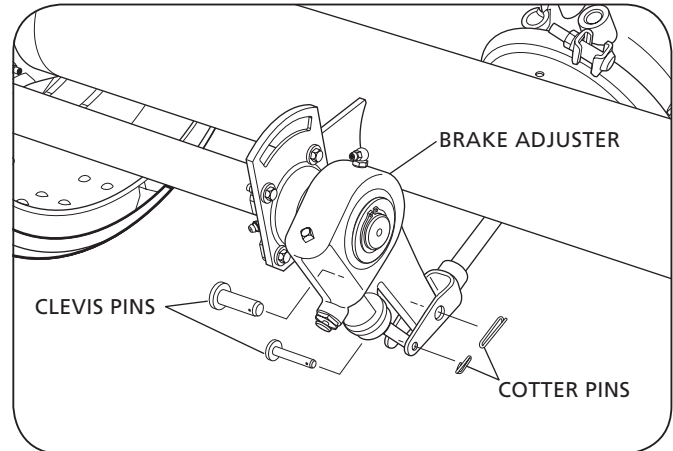

Figure 39

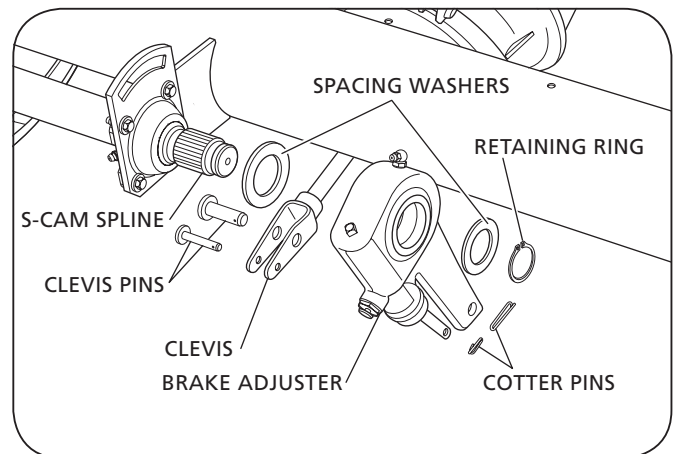
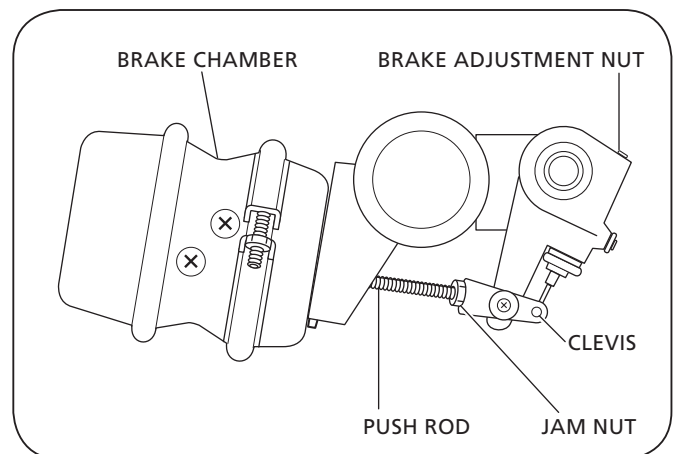

Figure 40



15. S-Camshaft and Bearing Removal Procedure

1. Remove the brake shoes and the brake adjuster as described in Section 11 and 13, respectively.
2. Remove the retaining ring from the spider end of the S-Camshaft (**Figure 41**).
3. Remove the S-Camshaft by sliding it out of the S-Camshaft bearing housing and bearings. It could be necessary to tap the end of the shaft with a soft mallet to release it from the bearings (**Figure 41**).
4. Remove the existing bolts securing the S-Camshaft bearing housing to the axle bracket (**Figure 42**).
5. Inspect the bearings assembly for wear and deterioration. Replace as necessary.

Figure 41

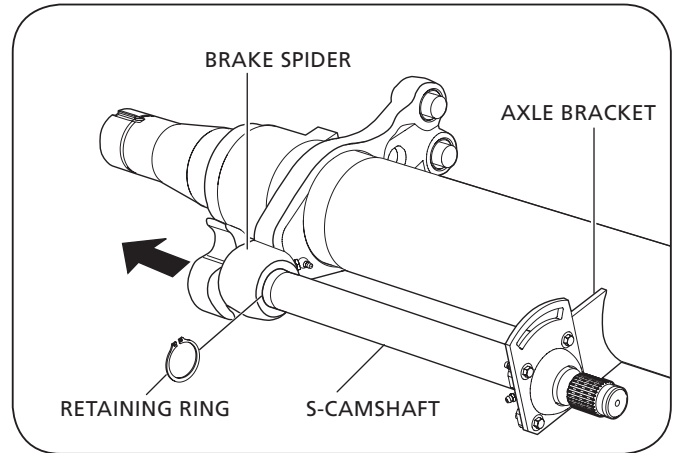
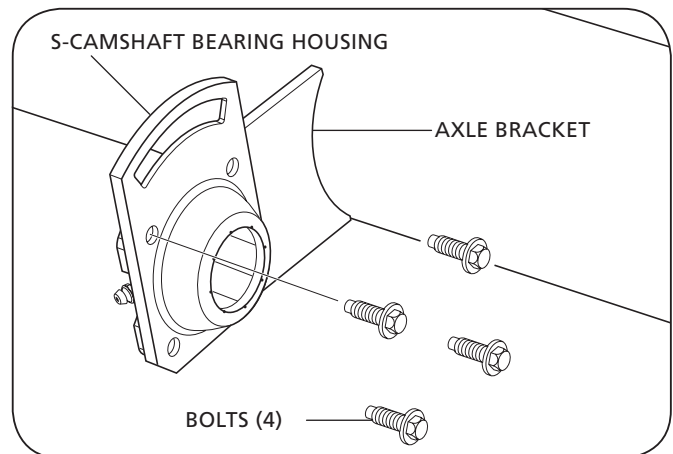

Figure 42



16. S-Camshaft and Bearing Installation

1. Attach the S-Cam bearing housing bracket to the axle bracket, securing it with the four (4) nuts and bolts (**Figure 43**). Tighten the nuts to 15-22 ft.-lbs. (20-30 N•m).
2. Install the S-Camshaft bearing into the brake spider, ensuring that the bearing is centered (**Figure 44**).
3. Install the guide plate, and cam seals on the S-Camshaft and slide the S-Camshaft and the washer assembly through the S-Camshaft bearing in the brake spider (**Figure 44**).

NOTE: Cam seals, refer to **Figure 44**, MUST be installed with the metal shoulder oriented toward the wheel, and the open end oriented toward the center of the vehicle. This facilitates complete lubrication of the s-cam bearing while allowing air to purge from the s-cam bearing away from the brake shoes.

CAUTION

Failure to center S-Camshaft bearing into the brake spider, and to properly orient cam seals, could not allow grease flow to bearing which, if not avoided, could result in premature bearing failure (**Figure 45**).

Figure 43

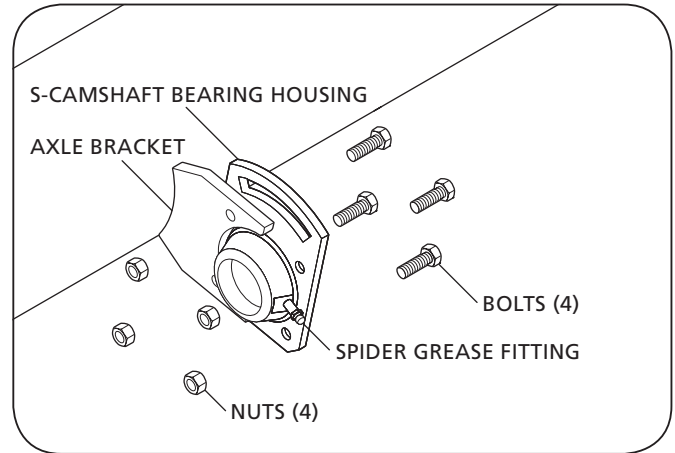

Figure 44

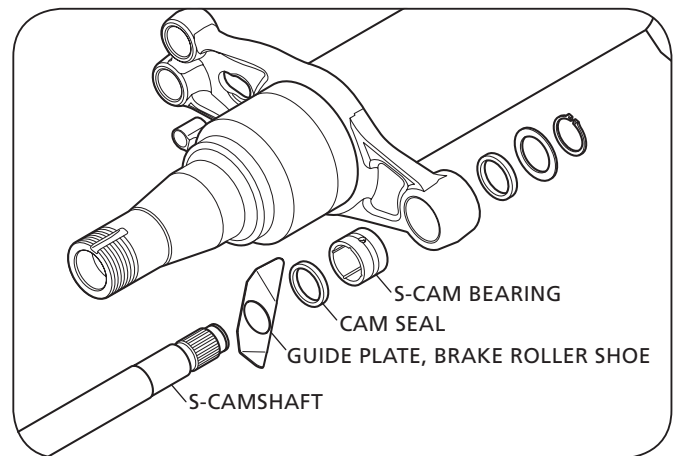
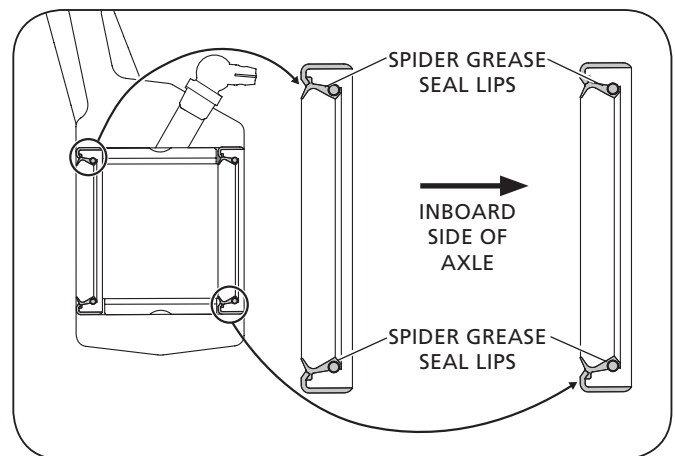

Figure 45



4. Install the cam seal washer and the retaining ring onto the S-Camshaft and slide the S-Camshaft into the S-Camshaft bearing housing bracket (**Figure 46**).
5. Install the brake shoes and the brake adjusters as described in Section 12 and 14, respectively.
6. Inspect the S-Camshaft installation to ensure that the correct S-Camshaft has been installed on the required side of the axle for proper operation (**Figure 47**).
7. Lubricate the S-Camshaft bearings with grease specified in the Lubrication Table in Section 22 (**Figure 48**, page 26).

Figure 46

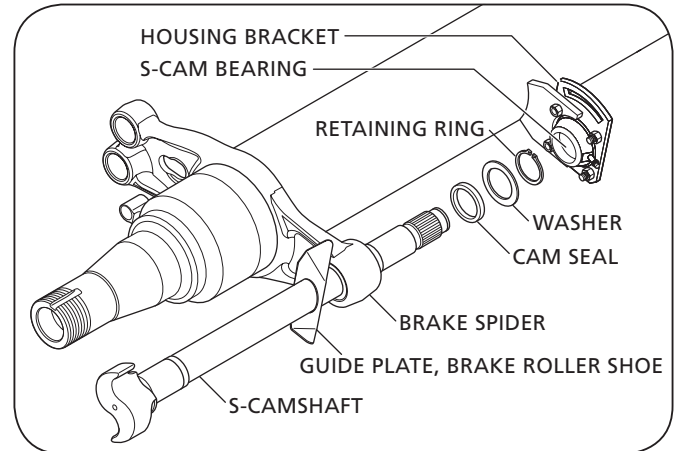
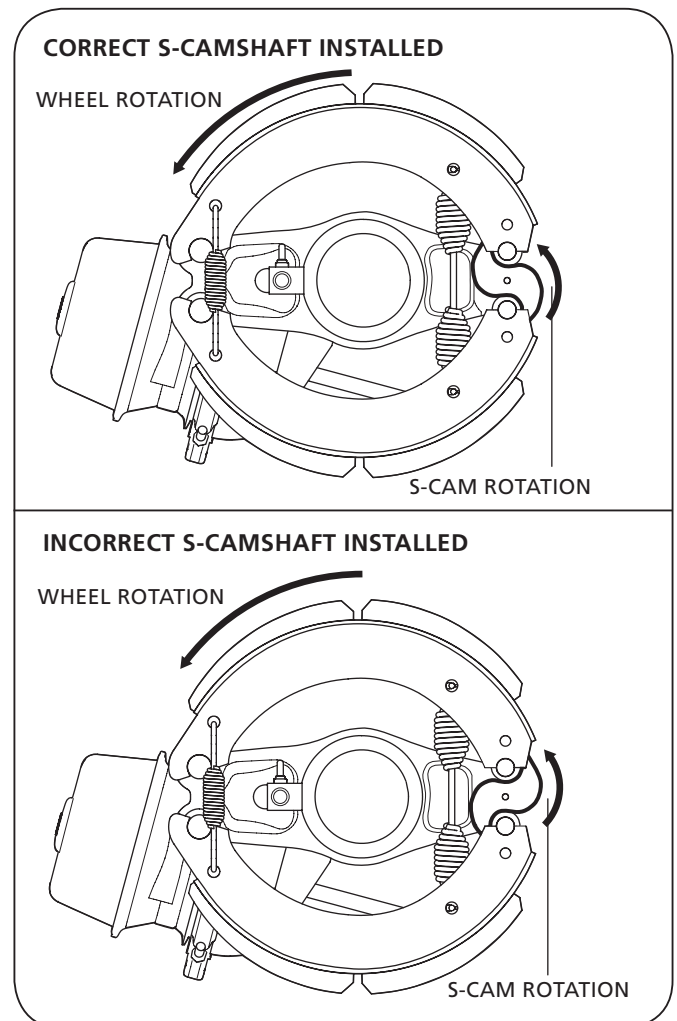

Figure 47



17. Brake Adjustment Procedure

1. Verify that the spring brakes are caged prior to beginning the adjustment procedure.
2. Adjust the brake adjuster until the brake lining contacts the brake drum, then back off 1/2 turn.
3. Apply the service brakes using normal operating pressure (average line pressure should be 90 psi, but not less than 80 psi). Check the following while brake pressure is applied.
 - The optimum distance of the push rod travel should be approximately 1.5" -1.75" (38-44 mm) (**Figure 49**).
 - Angle between the push rod and the brake adjuster with the brake applied, should be 95°-100° (**Figure 50**).
 - Brake lining to drum contact. A 0.010" feeler gauge should not fit between the lining and the drum contact area.
4. Release the air pressure from the service brake system and check to see that all brakes release to the normal relaxed position. If all the brakes do not properly release, Refer to Troubleshooting Chart in Section 23.

CAUTION

Failure to adjust the brakes in accordance with manufacturer's instructions prior to placing the trailer back in service will prohibit proper brake function which, if not avoided, could result in uneven brake system component wear.

5. Uncage the spring brakes.

WARNING

Failure to uncage the spring brakes in accordance with manufacturers' instructions after servicing is complete will prohibit proper brake function which, if not avoided, could result in death or serious injury.

Figure 48

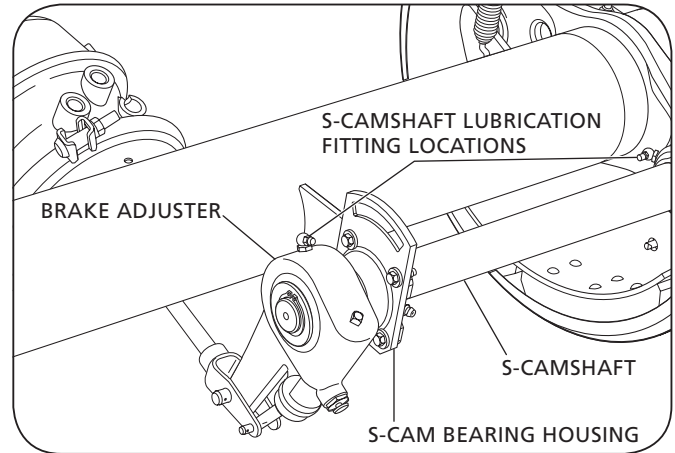

Figure 49

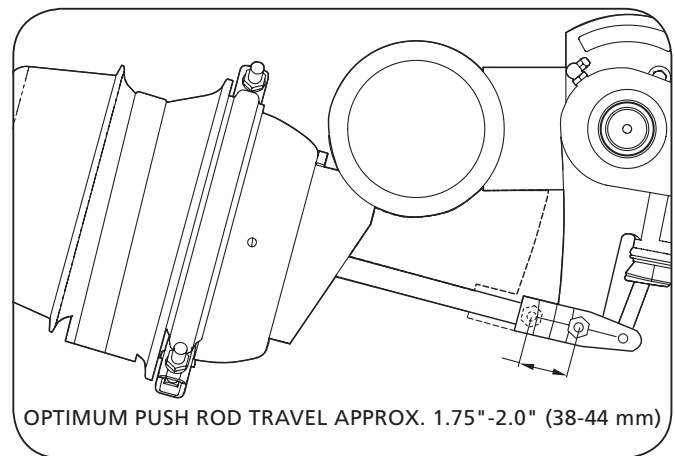
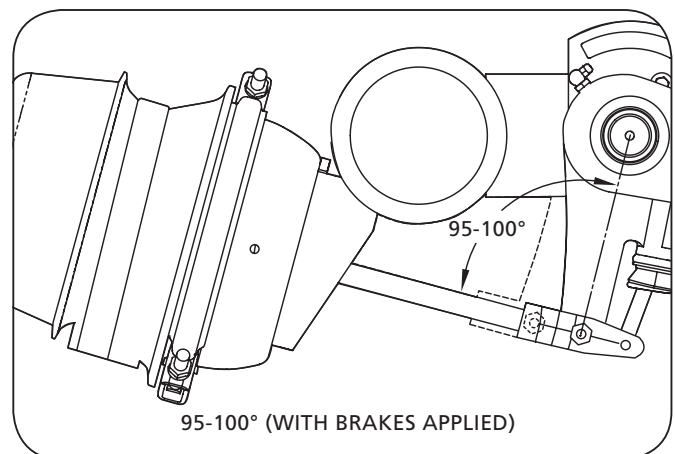

Figure 50



18. ABS Sensor Replacement Procedure

18.1 Sensor Removal

NOTE: ABS sensors **MUST** match the system. **DO NOT** mix sensors from different manufacturers.

1. Manually release the brakes.
2. Remove the brake drum assembly as described in Section 4.
3. Disconnect the ABS sensor connector and remove the sensor from the sensor holder by pulling straight out (**Figure 51**).
4. Remove the sensor retaining spring clip, if necessary.

18.2 Sensor Installation

NOTE: Be sure to use the correct spring clip for the sensor being installed.

1. Install the sensor retaining spring clip, if removed, into the sensor holder.
2. Install the ABS sensor into the spring clip and the sensor holder. Push the sensor in until it contacts the tone ring (**Figure 52**).
3. Connect the ABS sensor connector.
4. Re-install the drum using support device such as a drum dolly jack (**Figure 37**, page 21).
5. Adjust the brakes as described in Section 17.

Figure 51

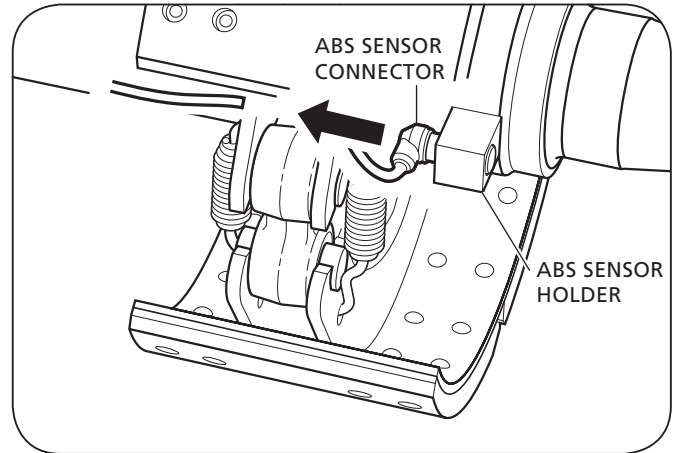
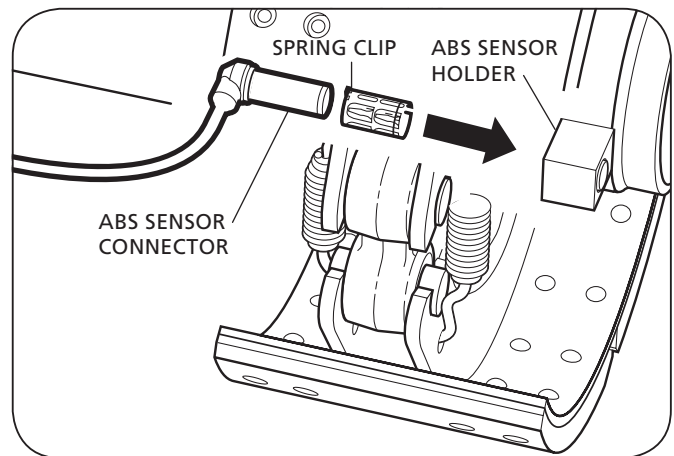

Figure 52



19. Wheel Installation Procedure

The following information is intended to provide basic wheel installation instructions. Refer to TMC RP222C for complete installation details.

1. Clean all mating surfaces on hub, wheels and nuts.
2. Rotate the hub so a pilot boss is at the top (12 o'clock) position.
3. Mount wheel(s) on hub. One or more of the wheel nuts can be started in order to hold wheel in position.
4. Tighten the top wheel nut first. Apply 50 ft.-lbs. (68 N•m) of torque to draw the wheel up fully against the hub.
5. Install remaining wheel nuts. Using sequence illustrated in **(Figure 53)**, tighten all wheel nuts to 50 ft.-lbs. (68 N•m) of torque.
6. Repeating sequence illustrated in **(Figure 53)**, retighten all wheel nuts to 475 ± 25 ft. lbs. (644 ± 34 N•m) of torque.
7. Check seating of wheel at the pilot bosses. Rotate wheel and check for any rotational irregularity.

⚠ WARNING Retorque all wheel nuts after 5 to 100 miles of service on the initial "in-service" following any installation of wheel to hub assembly.

20. Axle Alignment Inspection

NOTE: Alignment can be achieved using an optical device designed specifically for this purpose. Follow the instructions in the optical device operating instructions to align the axles.

1. To manually align the axles attached to the trailer, first pull the trailer in a straight line for a sufficient distance to release/clear any binds in the suspension.

NOTE: A straight, unbound suspension is the position of a suspension during normal operations.

Using the alignment procedures per the suspension manufacturer's recommendations, align the axles to the following specifications.

2. Measure the distance from the king pin to the centerline of the spindles on each side of the front axle. Dimensions A and B **MUST** be equal to within 1/8" (4 mm) **(Figure 54, A and B)**.
3. Measure the distance from the centerline of the spindles of the front axle to the centerline of the spindles of each additional axle. Dimension C and D **MUST** be equal to within 1/16" (1 mm) **(Figure 54, C and D)**.

Figure 53

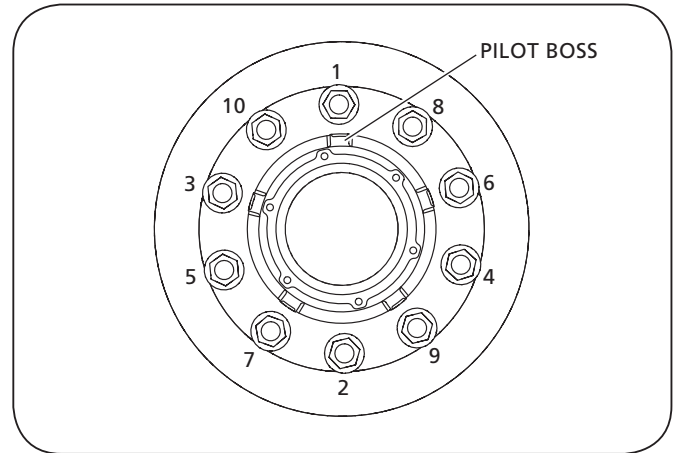
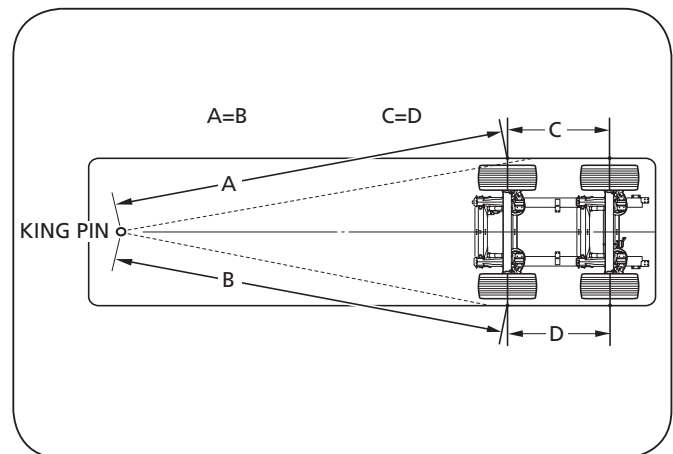

Figure 54



21. Routine Service Schedule

WHICHEVER OCCURS FIRST		PERIODIC CHECKS		
MILEAGE INTERVALS	AFTER FIRST 3,000 MILES	EVERY 10,000 MILES	EVERY 50,000 MILES	EVERY 100,000 MILES
TIME INTERVALS	AFTER FIRST MONTH	EVERY MONTH	EVERY 6 MONTHS	EVERY 12 MONTHS
VISUAL INSPECTION FOR WEAR/DAMAGE				
Check brake linings for wear.	■	■		
Check S-Camshaft for proper operation.	■	■		
Check brake adjusters for correct function.	■	■		
Check air brake system for leaks (brake applied).	■	■		
Check axle structural components for cracks or damage.	■	■		
Check hub lubrication level for excessive leakage.	■	■		
MECHANICAL CHECK				
Attention: Torque check wheel nuts after the first 5-100 miles (8-160 km) from date vehicle was placed into service and after every wheel removal. Continually check wheel torque every 10,000 miles (16,000 km), or at the intervals indicated in your vehicle owner's manual, whichever occurs first.	■			
Torque check all nuts and bolts to recommended setting.	■		■	
Check and adjust wheel bearing end play.	■			■
Pack hub bearings with fresh lubricant (also after every brake lining replacement, check hub bearing wear).				■
Lubricate S-Camshaft bearing bushings.	■	■		
SAFETY INSPECTION				
Check brake lining to drum clearance for correct adjustment – re-adjust clearance if necessary. Check service brake and parking brake for performance.	■	■		
SPECIAL SERVICE CONDITIONS				
Vehicles with long standing periods.	Service at specified time intervals, e.g. trailer used for storage or frequently left standing for several days at a time.			
Vehicles used under extreme conditions.	Service at suitably reduced intervals, e.g. trailer operating in continuous multi-shifts or in off-road construction sites.			

Warranty claims will only be accepted as long as the operation and maintenance instructions have been complied with and if SAF-HOLLAND approved spare parts have been fitted.

22. Torque and Lubrication Specifications

TORQUE SPECIFICATIONS	
COMPONENT	TORQUE VALUE
Grease Fitting, Spider	20-50 in-lbs (2-6 N•m)
Axle, Inner Nut	Refer to Section 7
Axle, Outer Nut	200-300 ft.-lbs. (271-407 N•m)
Air Chamber Nuts	80-125 ft.-lbs. (108-169 N•m)
Hubcap Bolts	12-16 ft.-lbs. (16-21 N•m)
Self-Threading Screw	15-22 ft.-lbs. (20-30 N•m)

LUBRICATION SPECIFICATION		
COMPONENT	SURFACE TO BE LUBRICATED	LUBRICANT
S-Camshafts	S-Camshaft Bearings (Four (4) Grease Fittings per Axle)	Lithium Complex Grease
S-Camshafts	S-Camshaft Spline	Never-Seez
Brakes	Brake Shoe Rollers anchor Pins	Never-Seez
Brakes – Brake Adjuster	Brake Adjuster Grease Fitting	Lithium Complex Grease
Axle	Bearings and Hubs	NLGI 00 Semi-Fluid Grease (Standard) 75W-90 Synthetic Oil (Optional)*

* Oil lubed bearings and hubs should remain lubricated with oil, grease lubed bearings and hubs should remain lubricated with grease.

NOTE: Intervals are based upon normal operations. Reduce intervals to compensate for abnormal operations or severe conditions. During inactive periods, sufficient lubrication must be performed for equipment preservation.

23. Troubleshooting Chart

PROBLEM	POSSIBLE CAUSE	RESOLUTION
Brakes will not release	Brake shoes bound up at anchor pins	Lubricate brake operating parts
	Brake hoses Restricted	Replace hoses
	Brakes out of adjustment	Adjust brakes
	Damaged brake assembly	Replace or repair as required
No brakes or insufficient brakes NOTE: All of the possible causes would result in brake lockup.	Source of air supply shut off at tractor	Open cutout cocks at rear of tractor cab or push control valve "IN"
	Low brake line pressure	Check air pressure gauge on tractor - inoperative
	Brake lines between tractor and trailer not properly coupled	Properly couple brake lines
	Reservoir drain cock open	Close drain cock
Dog tracking	Leaf spring broken	Replace complete spring
	Bent Axle	Replace or straighten axle
	Frame or suspension out of alignment	Straighten frame or align axles
Uneven tire wear	Over or under inflation	Inflate to proper pressure
	Loose wheel stud nuts or clamps	Tighten wheel stud nuts or clamps
	Loose or tight wheel bearing adjustment	Adjust bearings
	Axle bent or out of alignment	Straighten, align or replace axle
	Tires not properly matched	Match tires
	Improper acting brakes	Correct brakes as required
	Rapid Stopping	Apply brakes slowly when approaching stop
	High-speed driving on turns	Reduce speed
Grabbing brakes	Oil, grease or foreign material on brake lining	Reline brakes
	Brakes out of alignment	Adjust brakes
	Brake drum out-of-round	Replace brake drum
	Damaged brake chamber or internal assembly	Replace brake chamber/internal assembly
	Leaky or broken hose between relay valve and brake chamber	Replace or Repair as required
Excessive heat cracks on drum	Rapid stopping or poor air flow to brakes	Replace drum
	Out of adjustment	Adjust brakes
	Binding S-Cam, anchor pins or chamber rod end pin	Lubricate and free up
	Damaged brake assembly/brake drum out-of-round	Replace or repair as required
ABS inoperable		Refer to ABS manufacturer's service literature
Slow brake application or release	Lack of lubrication	Lubricate brake operating parts
	Excessive travel in brake chamber push rod	Adjust brakes
	Restriction in hose or lines	Replace hoses
	Defective brake valve	Replace brake valve

LUBRICATION

Wheel-End Lubrication

This section provides information on lubricating Meritor trailer axle wheel-ends with either grease or oil. **Figure 13.2.**

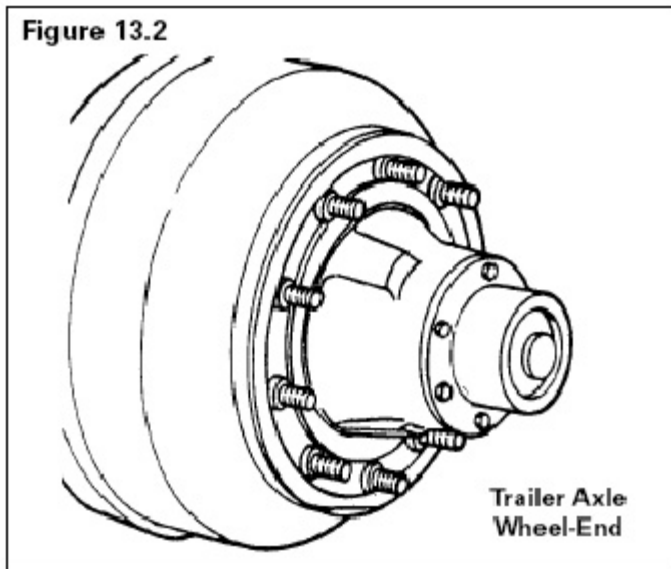

Oil Lubricated

1. The most common oils used in Meritor trailer axle wheel-ends have a designation of API-GL-5 (American Petroleum Institute – Gear Lubricant No. 5). This oil is also approved under military specification MIL-2105D. Refer to **Table O** in this section.
2. In addition to the GL-5 oils listed, oils with API grades GL-1, GL-2, GL-3 and GL-4 can also be used in trailer axle wheel-ends. These oils cannot be used in drive axles, or any application which employs hypoid, amboid, spiral, bevel, or planetary gearing.
3. Oil viscosity should be suitable for the climate in which the axle will be operated.
 - a. Low viscosity single grade gear oils, such as SAE 75W (Society of Automotive Engineers), should only be used in cold climates. Oil seals must be in excellent condition when using low viscosity oils to insure against loss of these thin fluids.
 - b. Multigrade oils, such as 80W/90, should be used where vehicles operate in both warm and cold climates.
4. Do not use thinning agents such as kerosene, gasoline, or other solvents that lower the viscosity of lubricants.
5. The recommended frequency of wheel-end oil changes depends on such factors as environment, speeds, and loads imposed on axle. For example, applications such as container chassis service put limited stress on wheel-end lubricant, allowing maintenance intervals to be extended. Other applications, such as off-highway dump trailer service, put severe stress on the wheel-end lubricant, requiring that maintenance be performed more frequently. The following information is therefore intended as a general guideline:
 - a. **General** – Change oil whenever it is contaminated or when wheel-end cavity is disrupted by removing spoke wheel or hub.
 - b. **Standard-Duty Service** – For standard-duty on-highway service, change oil every 100,000 miles or 12 months, whichever comes first.
 - c. **Heavy-Duty Service** – For heavy-duty on-highway, off-highway or combined on/off highway service, change oil every 30,000 miles or 6 months, whichever comes first.
6. Guidance for lubricating a wheel-end with approved gear oil (**Table O**) is as follows:
 - a. Note that detailed guidance for installing components such as seals, bearings, hubcaps and hubs is located in the “Assembly” section of this manual.
 - b. Coat bearing cones with oil.
 - c. Apply a light film of NLGI #1 or #2 **grease (not oil)** to axle spindle bearing journals to help protect them from fretting corrosion.

Figure 13.3.

Figure 13.3

APPLY GREASE
WHERE BEARING
CONES CONTACT
SPINDLE

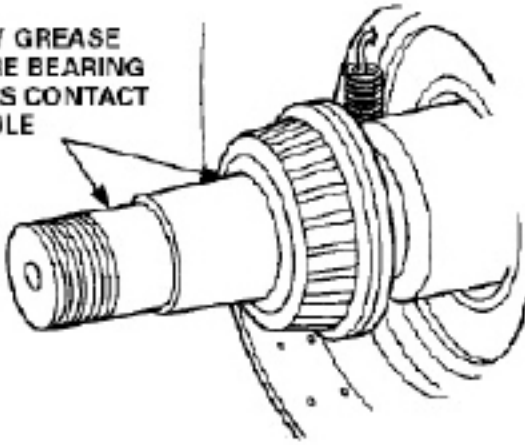

CAUTION

It is important not to overfill the wheel-end cavity with lubricant. Wheel-end oil level should never exceed the middle of the hubcap. Also, make sure any excess oil is wiped away since it can contaminate brake linings and cause poor brake performance.

- d. Fill wheel-end with an approved gear oil to hubcap fill line. Note that oil must be given sufficient time to settle prior to final check of oil level. This is especially important in cold conditions. **Figure 13.4.**

Figure 13.4

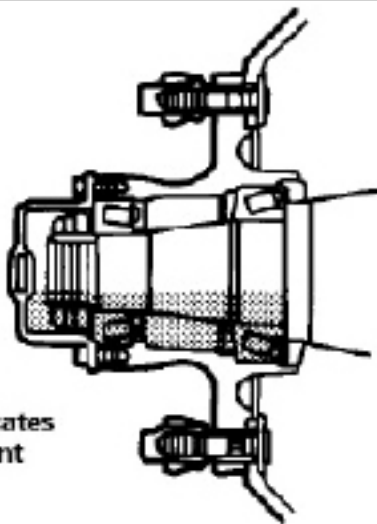

Rollers on Hopper Doors

Generously lubricate rollers and grease universal joints monthly. This will help to force moisture and dirt from the bearings.

- 7. Inspect wheel-end oil level at least every 1,000 miles (1,600 km). To check, make sure vehicle is on level ground then clean hubcap window and observe oil level. Add lubricant if oil level is down more than 0.25 inch (6.3 mm) from fill line. **Figure 13.5.**

Figure 13.5

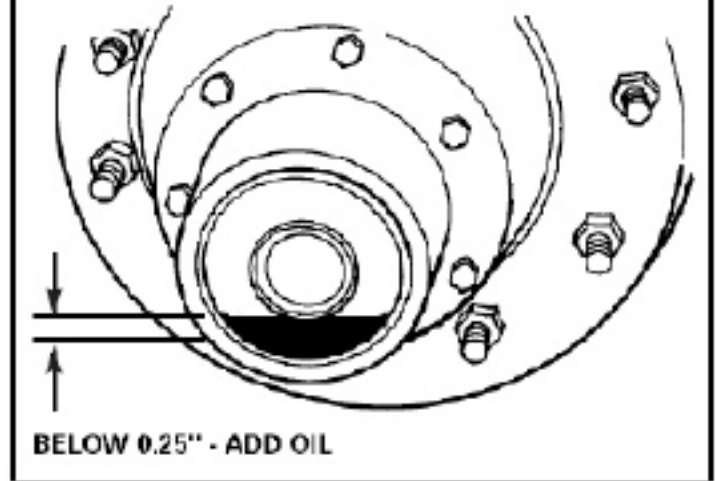

Greasing the Axle

On each axle there are six grease zerks that need to be greased every six months or every 10,000 miles. The grease zerks are located by the arrows shown below.

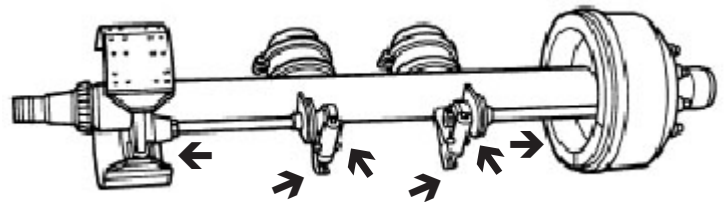

CAUTION

Make sure any excess grease or oil is wiped away since it can contaminate brake linings and cause poor brake performance. If necessary, clean the disc or the drum and replace contaminated linings.

WIRING

Junction Box

Demco Grain Trailers use a Truck-Lite 88 sealed wiring harness. A 7-pole nose box is used in conjunction with the wire harness.

Trailer Lights

The table below provides wire color codes for all trailers:

Yellow - Left Turn	Brown - Tail Lights	Green - Right Turn	White - Ground
Red - Stop Light	Blue - A.B.S	Black - Clearance, Cluster and License Plate	

CLEANING THE TRAILER

It is imperative trailers constructed of steel be kept clean of salt and other harmful elements. Failure to wash your trailer regularly and properly care for the paint and body may void any paint warranty claims if the trailer shows signs of neglect or abuse.

When cleaning the trailer use a mild soap and rinse. Wash underneath both slope areas, kingpin, suspension areas and outside walls.

Keeping your trailer clean will help rid your trailer of salt and other harmful elements. This will help keep your trailer looking new and improve it's resale value.

VISUAL INSPECTION

For safe operating conditions and longer component life make these visual inspections before the trailer is released for work. Remember the Department of Transportation mandates you do this inspection.

1. Check the angle of the chassis.
To get conditions for least tire wear, a loaded trailer must travel parallel to the highway. A level angle of the chassis permits correct wheel chamber without toe-in or toe-out.
2. Check the tires.
The tires of each dual wheel must be matched to a minimum of 0.125" (3.2 mm) of the same rolling radius and a minimum of 0.75" (19 mm) of the same rolling circumference. The tires also must have equal air pressures.
3. Check the brake drums and linings.
Both wheel ends of each axle must have the same type of lining and drum equipment. Both tandem axles also must have the same kind of lining and drum equipment.

NOTE: Always follow the brake lining specifications supplied by the vehicle manufacturer.

4. Check the thickness of the brake lining.
The thickness of the brake lining must be the same on each shoe of the brake and on each side of the axle.
5. Check the brake system.
Apply the brake and check for air leaks at the brakes, air tanks, hoses and valves. When the brakes are applied, the brake shoes must move quickly and the lining must press against the drum. When the brakes are released, the brake shoes must retract fully.
6. Check for leaking lubricant at the wheel ends.
Leaking lubricant is caused by worn or damaged seal, or wrong gasket or seal installation.

GRAIN TRAILER LIMITED GENERAL WARRANTY

This warranty applies to all grain trailers manufactured by Demco. All goods manufactured by Demco shall be free from all defects in materials or workmanship under normal use and service, with loads not to exceed Manufacturer's rated capacity and speed. Applied only to the original owner, as evidenced by a completed warranty registration on file at Demco, for a period ending 12 months from the date of delivery.

THE WARRANTY REGISTRATION MUST BE COMPLETED AND RETURNED TO DEMCO WITHIN 30 DAYS OF DELIVERY OF THE PRODUCT TO THE ORIGINAL OWNER OR ALL WARRANTIES WILL BE NULL AND VOID.

All claims, for defective goods arising under this limited warranty, must be made in writing immediately upon discovery, but in no event, later than 12 months from the date of delivery to the original owner.

The limited warranty is the sole and exclusive warranty made or given by Demco in connection with the manufacture of sale of goods and is in lieu of all other warranties of any type or kind whatsoever, whether expressed or implied, written or oral. The provision hereof may not be modified, altered, or extended except in writing signed by an authorized representative of Demco.

- ◆ This warranty applies only to parts or components manufactured by Demco, which is defective in material or workmanship.
- ◆ This warranty does not cover normal maintenance, service or adjustments.
- ◆ This warranty does not cover depreciation or damage as a result of accident, negligent handling, inadequate maintenance, or improper operation.
- ◆ This warranty does not cover damage due to unauthorized modifications or repairs by purchaser prior to Demco inspection and approval.
- ◆ This warranty does not cover any purchased components such, as but not limited to; couplers, tires, axle assemblies, suspensions or any nonstandard feature or items specified by the purchaser.
- ◆ This warranty does not expand, enlarge upon, or alter in any way, the warranties provided by the manufacturers of purchased components.

In the event that a claim shall arise under this limited warranty, Demco may at its option repair the affected goods, replace the affected goods, or refund an equitable portion of the purchase price of the affected goods. The purchaser understands and agrees that, in the event of a defect in material or workmanship, the remedies are limited to repair or replacement, at Demco's option, such part or parts which examination shall disclose to manufacturer's satisfaction to have been defective.

All affected goods shall be held for inspection by Demco or its representatives and no claim hereunder shall be payable in connection with repairs made by purchaser prior to Demco's inspection or without Demco's prior consent.

No claim shall be payable under this limited warranty unless purchaser shall provide Demco with the following information in writing in a timely manner:

- ◆ VIN (Vehicle Identification Number) of affected goods.
- ◆ Number of days, weeks or months affected goods in service.
- ◆ Location of affected goods.
- ◆ Description and pictures of alleged defect.

In no event shall company be liable to purchaser for indirect, incidental or consequential damages or injuries including, but not limited to downtime, cost of labor or materials, loss of profits to purchaser's business or goodwill, resulting from breach of warranty hereunder and all damages resulting from defective goods, whether arising in tort, contract, or warranty except as specifically herein provided are waived by purchaser.

With respect to all other parts not manufactured by Demco, the respective manufacturers warranty will be assigned to the purchaser.

Axle Beam	limited 5 years
Axle Hub & Bearing Assembly	limited 1 year
Spring Suspension	limited 5 years
Air Ride Suspension	limited 3 years
Landing Legs	limited 2 years
Anti-Lock Braking System	limited 3 years or 300,000 miles
Lights	limited 1 year
Valves	limited 6 months

Tire Warranty can be found in the manifest holder on the kingpin.

There are no warranties for used products or products that have been repaired, altered, modified, overlooked, subjected to misuse, negligence, accident or ordinary wear and tear.

Operator is required to check wheel nuts, U-Bolts, radius rod bolts, and all other fasteners. Axle alignment, tire wear, tarp wear, and oil level in hubs must be inspected. If needed, operator should make proper adjustments to insure ill life of equipment. **These item's need to be checked the first 100 miles and again at 500 miles and periodically thereafter.** These inspections and adjustments are very important and must be performed.

State and Federal Laws require a daily inspection of this vehicle by the operator.

Demco products are sold without any express warranty except as set forth by this warranty.

This warranty is effective March 1, 2008 and supersedes all previous Demco, warranty policies.

DEMCO

GRAIN TRAILER LIMITED WARRANTY REGISTRATION

Your new Grain Trailer is covered by a limited warranty.
To initiate the warranty this form MUST be completed and returned to
Demco within **30 days** of delivery.

PLEASE PRINT OR TYPE

Owner's Name	Vehicle Identification Number
PO Box / Street Address	Trailer Description
City, State, Zip	Dealership Name
Telephone Number	City, State, Zip
Email	Telephone Number
Date of Purchase	Dealer Representative
Intended Use: <input type="checkbox"/> Rental <input type="checkbox"/> Personal <input type="checkbox"/> Farm/Ranch <input type="checkbox"/> Commercial <input type="checkbox"/> Government	
The Owner's Manual has been given to me and explained. I have read and fully understand the safe operation and the proper servicing and maintenance of the above trailer, and the terms of the limited warranty shown inside the manual.	
Purchaser's Signature: _____ Date: _____	
Pre-Delivery Service: This trailer was carefully prepared for delivery, inspected, and adjusted according to factory recommendations before delivery to the retail purchaser.	
Delivery Service: The limited warranty was explained, and a copy was presented to the retail purchaser along with the Owner's Manual.	
Dealer Representative Signature: _____	

Please mail to the following:

DEMCO
4010 320th Street
BOYDEN, IA 51234



Cut along dotted line



Cut along dotted line

THIS PAGE INTENTIONALLY LEFT BLANK

NOTES

DEMCO

4010 320th St., Boyden, IA. 51234

Phone: (712) 725-2311

Fax: (712) 725-2380

Toll Free: 1-800-54DEMCO (1-800-543-3626)

**Demco warranty policies, operator manuals, and product registration
can be found online:**

www.demco-products.com

