



Vertical
355-570 Cubic Feet



**Single Screw & Small
Frame Twin Screw Models**



F355 Twin



F470 Twin



F425 Single



F510 Single

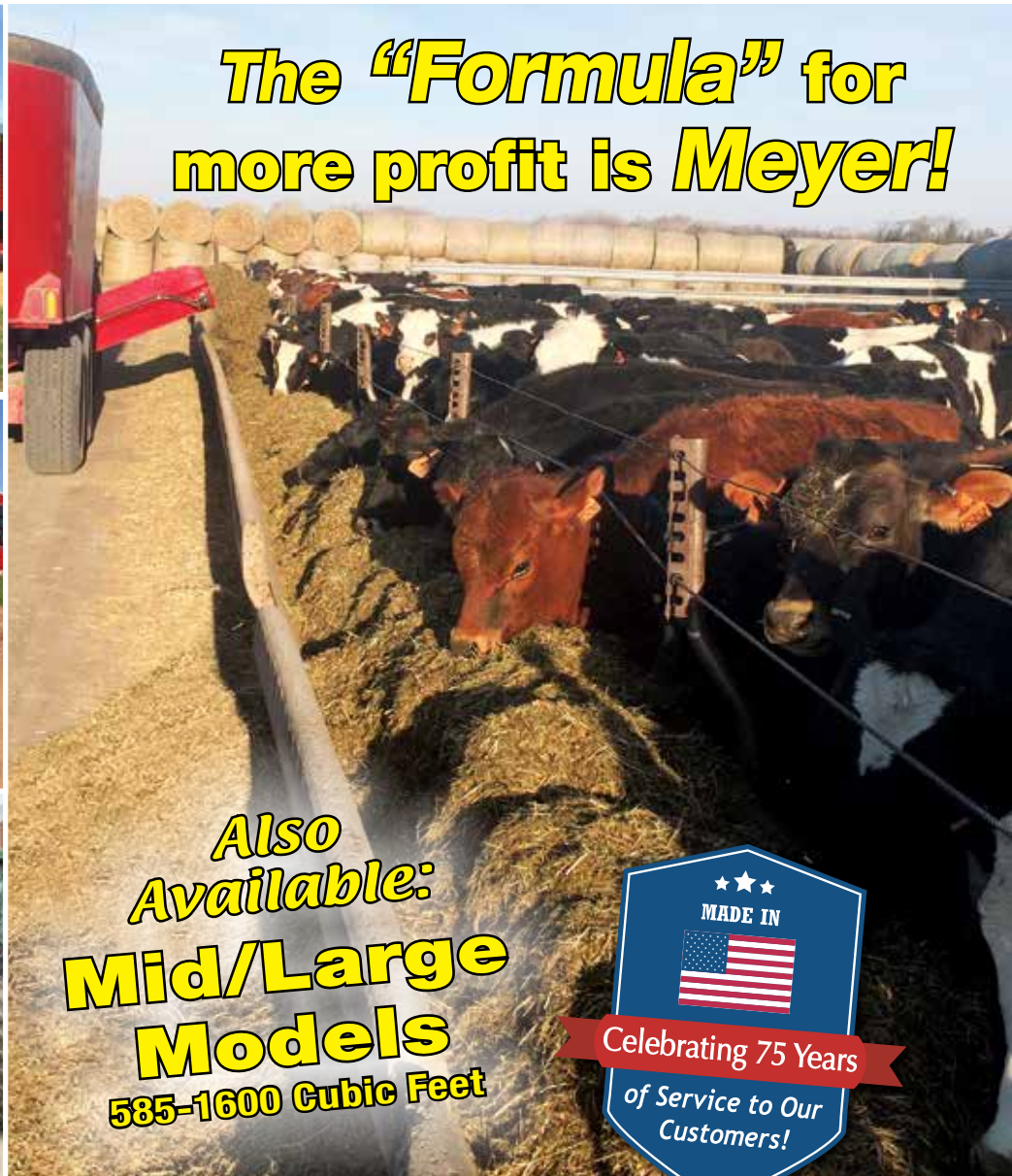

**The "Formula" for
more profit is Meyer!**

**Also
Available:
Mid/Large
Models
585-1600 Cubic Feet**



FORMULA

Nutrition Solutions

- Faster Processing
- Faster Cleanout
- Precise Rations
- Less Horsepower
- Lower Load Height



Small Frame Twin Screw



Models F355 – F470

Unique **3 piece knife design** offers added strength, simple adjustability and reduced replacement costs. (Tungsten carbide coated knives).

Cone top resists buildup especially combined with our fast auger speed!

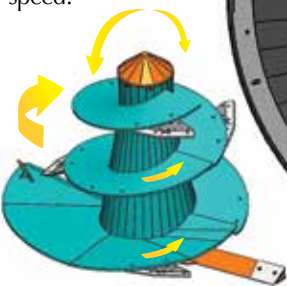

Precisely engineered augers propel your ration up the center of the auger and then down along the outside walls for fast processing while maximizing end-to-end movement between the front and rear screw.

Lead edge scraper is adjustable and replaceable, it is responsible for initiating efficient feed movement in the Formula Mixer. (Heat treated-high carbon steel).

Door tracks are poly lined for reduced wear & stress. Less freeze ups and easy replacement!

All Meyer Formula models **weigh the mixer body as well as conveyors** for the best accuracy possible.

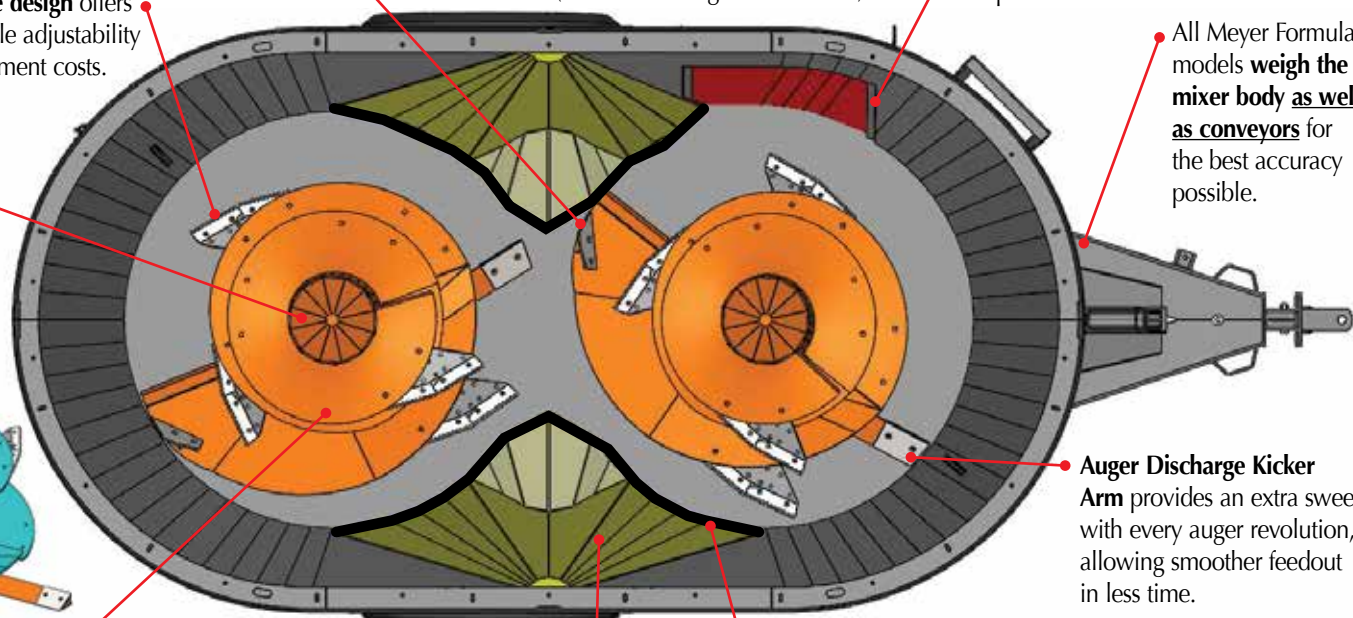

Set-Back Baffle Design Creates fast end-to-end (horizontal) transfer while eliminating concerns of bale wedging!

Step Baffle System aids feed movement, reduces horsepower requirements while eliminating overprocessing! Made from High Carbon Steel for reduced wear. (Twin Screw Models Only)

Auger Discharge Kicker Arm provides an extra sweep with every auger revolution, allowing smoother feedout in less time.

Heart of the Formula!

Direct, In-Line Drive System (Twin Screw):

- Direct, in-line drive system with shear bolt protection
- 540 PTO drive with a single speed design
- 1000 PTO drive optional
- 40 RPM max speed for faster processing, unloading and cleanout
- Robust planetary drives / compare us to the others!



F470



Strong, Integrated Frame

- Engineered for the lowest load height – 7' on F355!
- Heavy duty 3 point scale system
- Large, 385/65x22.5 recap tires handle well on hard surface or soft terrain.

Twin-Small Frame Model Features

- 355-520 cu. ft. capacity
- Front or side door models
- Wide selection of conveyor options (belt or chain)

Dual-Adjustable Hay Stop

- **Hay Stops** are double acting and easily adjustable for easy tuning when processing hay.
- Single and Twin Models





Single Screw Models

Models F425 - F510

The Meyer F425 & F510 have many of the same features as their twin screw brother, in a wider profile Single Screw Design.

Simple - Efficient

Single Screw Models

- Direct, In-line Drive with shear bolt protection
- 1000 RPM PTO Drive for reduced start-up torque
- 40 RPM Max auger speed for fast processing, unloading and cleanout
- High capacity, simple planetary drive

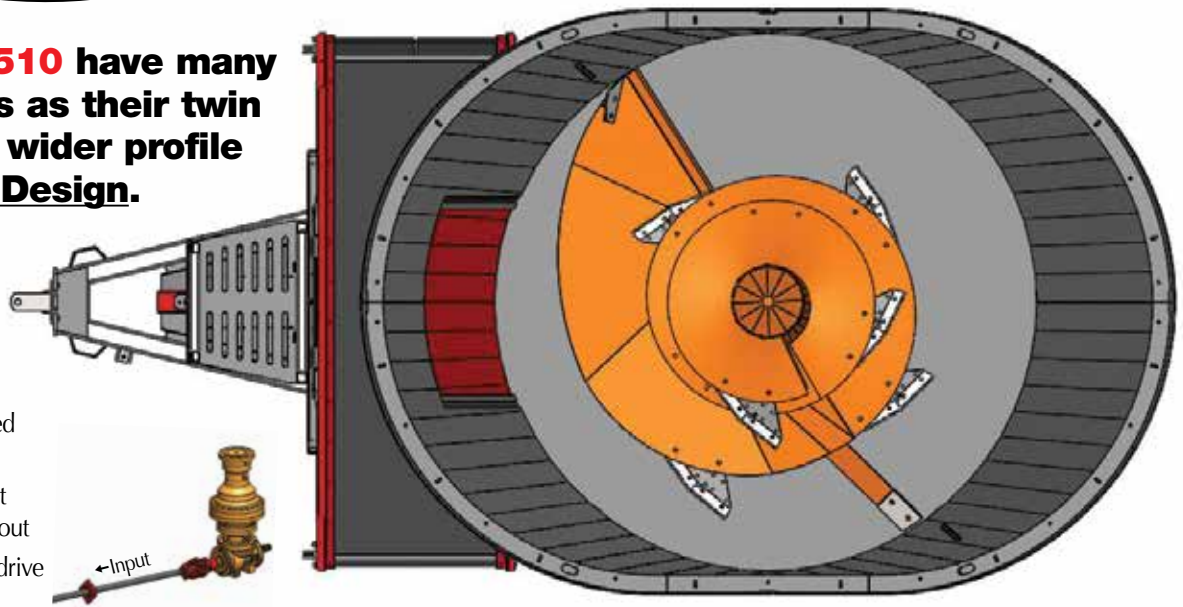

Single Screw Model Features

- 425-570 cu. ft. capacity
- Front or side door models
- Wide selection of belt or chain conveyor discharges
- Viewing platform optional on all front door models – tank mounted ladder standard



Heavy Duty Tubular, Independent Frame

(single screw models)

- 4 point Scale System
- All conveyors are tub mounted which means your product is weighed both in the mixer and on the conveyor.
- Standard axle consists of an in-line quad system (4 tires)
- Multiple tire options to meet your needs



Formula Features and Options



Shear Bolt Protection

Single Screw and Small-Frame Twin Screw models are all equipped with rapid detach PTO systems for simple, quick shear bolt replacement if necessary.



Easy Maintenance

OIL RESERVOIRS – easily accessed from the side of the mixer to monitor oil levels in your planetary gearboxes. Formula mixers feature fully-filled planetaries so all bearings (including the top one) are lubed in oil - no need to grease the top bearing manually. (Twin Screw Model pictured)



Scale Packages

Meyer offers a wide variety of Scaleheads to meet your needs. We also offer remote tank mounted indicators, mounting brackets and cab-controlled wireless models.



Belt Capacity Extensions are available for Single or Twin Screw Models. Adds approx. 10% to mixer capacity (Optional).



Formed Hay Ring Assembly is ideal when processing large amounts of long-stemmed hay in your ration (Optional).

Stainless Steel Side Liners & Baffle Liners

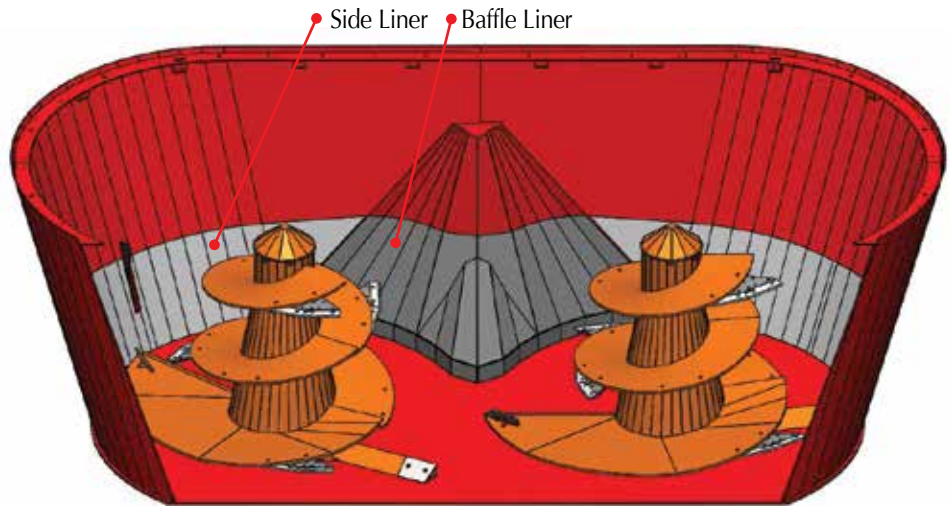

(Baffle liners on twin screw models only) are available for high use applications. Heat Treated Auger Flighting is also available to extend auger life.

Magnet Options:

Formula Mixers can be equipped with door frame magnets or slide tray magnets on side door models. Drape magnets or powered rotary magnets are available on front door models. Tank mounted magnets are available on all mixer models and deflector magnet systems on most models with incline conveyors.

Side Door / Front Door / Side & Front Door



Drape Magnet



Door Frame



Slide Tray



Powered Rotary
**select models only*



Tank Style



Deflector System



FORMULA//////



Door and Conveyor Options

Front Door Options

↙ Belt or Chain Incline Discharge Conveyor

- 24/36/48/60" Belt – 24/36/48/60" Chain
- Hydraulic folding w/LH or RH discharge
- Unique dual belt design / no carry back! (chain available)
- Dual belt conveyor unloads off flat side as well
- Drape / deflector / tip-off magnets available!

Flat Front Belt Extension Conveyor →

- Flexibility of RH & LH discharge w/ same pass
- Quiet operation
- Includes 8" side shift to right or left on poly lined track
- Belt drape magnet set available
- Deluxe, powered rotary magnet available



Belt Incline Conveyor pictured

Side Door Options

Hydraulic Folding Slide Tray - (far right) →

- Folds up for extra clearance during transport
- Includes magnet set
- Provides additional feed clearance from tire

Belt Discharge Conveyor →

- 24"/36"/48"/60"/72"
- Smooth, consistent deliveries to match your operation
- Magnet package available
- Chain conveyor available in lieu of belt

12" Belt Slide ↓

- Simple and efficient
- Pictured below w/optional Magnet package



Door Options



FRONT DOOR - Pictured with Flat Front Belt Conveyor (includes Hydraulic Shift).



SIDE DOOR - (Left, Right or Both) Pictured with Hydraulic Folding Slide Tray.



Meyer offers the Widest Variety of Conveyor Styles & Options!

F425 Single



REAR COMMODITY DOOR

- Available on all models except 355
- Perfect for pre-mixes and bale processing
- Fast off-loads!



4 Models from 355 – 570 Cubic Feet

Pull Type Model Specifications

FORMULA IIII

	SINGLE AUGER		TWIN AUGER	
	F425	F510	F355	F470

MODEL - DIMENSIONS (INCHES)	F425	F510	F355	F470
A - Overall Length-Side Door / Front Door	193"/229"	197"/232"	215"/245"	219"/249"
B - Mixing Chamber Length	155"	162"	169"	175"
C - Overall Height (Standard Tires)				
- Standard Tire Size (Quantity)	12.5LX15-12 PLY (4)	12.5LX15-12 PLY (4)	385/65R22.5 (2)	385/65R22.5 (2)
- Optional Tire Size (Quantity)	245/70R19.5 (4)	245/70R19.5 (4)		
- Optional Tire Size (Quantity)	380/60R16.5 (4)	380/60R16.5 (4)		
- Base Machine	97"	107"	84"	98"
- Belt Extensions	103"	113"	90"	104"
- Hay Retention Ring	102"	112"	90"	104"
D - Tread Width	103"	103"	98"	98"
E - Transport Width-Frt Conv./Side Conv. w/36" ext	122"/131"	123"/132"	98"/110"	98"/110"
F - Max Discharge Reach				
- Frt Cross Conveyor-Flat	10"	10"	7"	7"
- Frt Cross Conveyor-Belt Incl. -24°/36°/48°	29°/37°/49°	29°/37°/49°	20°/26°/35°	20°/26°/35°
- Frt Cross Conveyor-Chain Incl. -24°/36°/48°			17°/29°/40°	17°/29°/40°
- Side Conveyor-24°/36°/48°/60°/72°	40°/47°/58°/69°/80°	40°/47°/58°/69°/80°	22°/33°/45°/56°/67°	22°/33°/45°/56°/67°
- Side Slide Tray	21"	21"	5"	5"
- Side Belt Extension	18"	18"	3"	3"
G - Max Discharge Height				
- Frt Conveyor-Flat Belt	25"	25"	20-1/4"	20-1/4"
- Frt Conveyor-Belt Incl. 24°/36°/48° @40°	39°/44°/52°	39°/44°/52°	35°/40°/48°	35°/40°/48°
- Frt Conveyor-Chain Incl. 24°/36°/48° @ 45°			38°/47°/56°	38°/47°/56°
- Side Conveyor-24°/36°/48°/60°/72° @45°	45°/51°/59°/68°/76°	45°/51°/59°/68°/76°	34°/43°/51°/60°/68°	34°/43°/51°/60°/68°
- Side Slide Tray	17"	17"	8"	8"
- Side Belt Extension	26"	26"	16"	16"
SPECIFICATIONS				
Mixer Capacity				
- Cubic Feet-No Extension/With Extension	425/480	510/570	355/400	470/520
- Maximum Net Load - Pounds	14,200	16,600	12,000	15,600
Augers				
- Number	1	1	2	2
- Diameter	107"	107"	68"	68"
- RPM-Standard	40	40	40	40
- Upper Flighting Thickness	5/8"	5/8"	1/2"	1/2"
- Lower Flighting Thickness	3/4"	3/4"	5/8"	5/8"
- Knives-Adjustable - (Std./Max Avail.)	5/7	6/8	4/7	4/8
Drive				
- Planetary	In-Line Drive	In-Line Drive	In-Line Drive	In-Line Drive
- PTO Drive (Std./Opt.)	1000 RPM	1000 RPM	540/1000 RPM	540/1000 RPM
- Protection	Shear-Bolt	Shear-Bolt	Shear-Bolt	Shear-Bolt
Discharge				
- Door Opening - Front	42" x 40"	42" x 40"	35" x 40"	35" x 40"
- Side	35" x 40"	35" x 40"	35" x 40"	35" x 40"
- Rear	42" x 40"	42" x 40"	n/a	35" x 40"
Conveyor Width - Front/Side	36" / 36"	36" / 36"	30" / 36"	30" / 36"
Flat Front Cross Conveyor Travel-Left or Right	8"	8"	8"	8"
Tub and Trailer Construction				
- Floor Thickness	5/8"	5/8"	1/2"	1/2"
- Sidewall Thickness	1/4"	1/4"	1/4"	1/4"
- Trailer or Subframe	In-Line Quad	In-Line Quad	Single-Axle	Single-Axle
- Optional Axle				
- Spindle Diameter (Quantity)	2-3/4" (x4)	2-3/4" (x4)	2-7/8" (x2)	2-7/8" (x2)
- Scale System	4-point	4-point	3-point	3-point
- Tongue Weight - % Gross	10%	10%	10%	10%
- Tractor Requirement - PTO HP	90	100	75	90

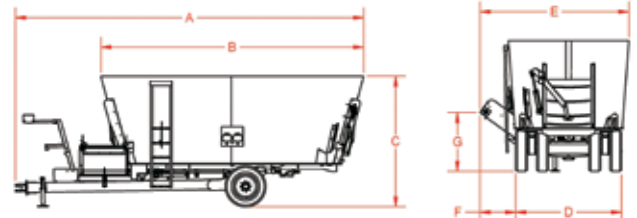

Small Frame Twin

Model	Load Height	Capacity
F355	> 84" – 90"	355 to 400 cu ft
F470	> 98" – 104"	470 to 520 cu ft



Single Screw

Model	Load Height	Capacity
F425	> 97" – 103"	425 to 480 cu ft
F510	> 107" – 113"	510 to 570 cu ft



**Medium-Large Frame
Twin Screw Models Available
585-1600 Cubic Feet**

YOUR DEALER IS:



Connect with us!

Meyer Mfg. Corp.

Dorchester, Wisconsin 54425

Phone: 715/654-5132 • FAX: 715/654-5513 • 1-800-325-9103

email: sales@meyermfg.com • www.meyermfg.com