



Parts Manual

Mfg. No: 5901811
FB2000 Hurricane Series Stand-On
Debris Blower



5109061 - Tire, Debris Blower, Pavement Tire.....

Not For
In Reproduction

Model Components	Page
Blower Group.....	4
Decal Group - Brand and Model.....	6
Decal Group - Safety and Operational.....	8
Electrical Group.....	10
Electrical Schematic.....	12
Engine Group.....	14
Fuel Tank and Hose Group.....	16
Handle Bar Group.....	18
Hydraulic Group.....	20
Instrument Control Panel Group.....	22
Main Frame Group.....	24
Motion Control Group.....	26
Parking Brake Group.....	28
Wheel and Tire Group.....	30
Torque Specification Chart.....	32

Not For
In Reproduction

Blower Group

Note: Unless noted otherwise, use the standard torque specifications

Mfg. No: 5901811

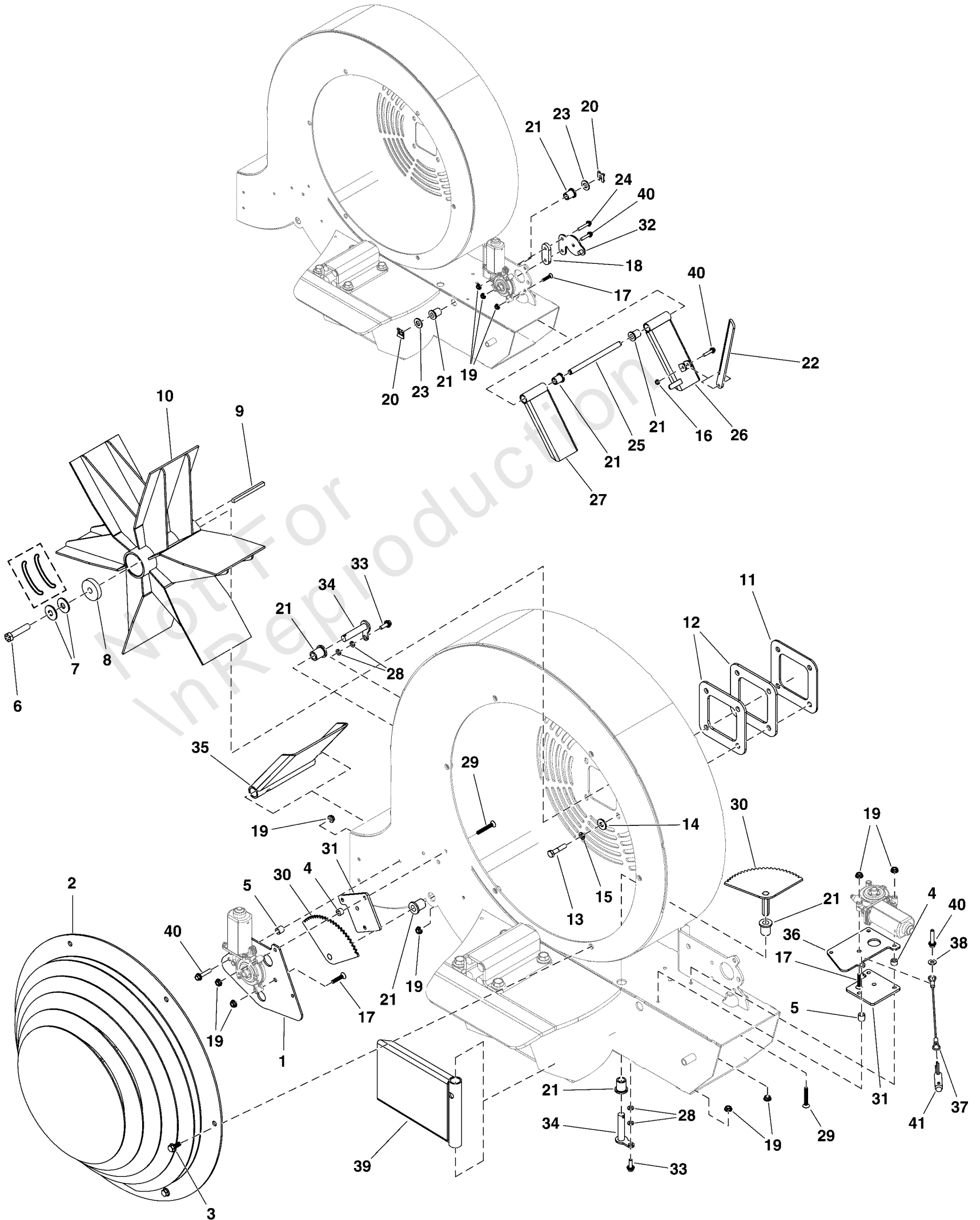

Blower Group

REF NO	PART NO	QTY	DESCRIPTION
1	5107338A	1	PLATE, RIGHT DEFLECTOR COVER - BLK -(Plate only, motor shown for reference only.)
2	5418562A	1	WELD, SAFETY COVER X3 - BLK
3	80003531	6	SCREW, 5/16-18X0.750, GR5, WHIZ-LOCK, ZC
4	5107396	4	SPACER, .265 X .50 X .320, CZ
5	5106902	3	SPACER, .265 X .50 X .483, CZ
6	5025016X16	1	BOLT, 7/16-20 X 2 -(Torque impeller mounting bolt to 65 ft-lbs (88 Nm))
7	5025585	2	BELLEVILLE WASHER, 1.1875 X .442 X .098
8	5106924	1	WASHER, IMPLR, 1-3/4OD X 7/16ID
9	5106925	1	KEY, 1/4SQ X 3-3/8
10	5419589	1	WELD, IMPELLER, 19.00 OD
11	5107364	1	SPACER, MOTOR PLATE 10GA, CZ
12	5107363	2	SPACER, MOTOR PLATE 7GA. CZ
13	5025025X12	4	BOLT-HEX, 5/16-24 X 1-1/2", GD8, PHOS
14	5025337	5	WASHER, 5/16" USS
15	5025170	4	WASHER, 5/16 LOCK YZ
16	5025095	1	HUT, HEX NYLON LOCK, 1/4x20"
17	5106874	4	SCREW, 1/4-20 X 1-1/4, ALLEN, SS
18	5107334AA	1	PLATE, RACK SPACER - BLK
19	5025126	15	NUT, Hex, Serrated Flange, 1/4-20
20	5106951	2	CLIP, SAFETY
21	5106943	8	BUSHING, 1/2 X 3/4 X 1F (0117-081216)
22	5107335	1	PLATE, DEFLECTOR RACK,CZ
23	5025158	2	WASHER, 1/2 SAE
24	5106873	1	BOLT, 1/4-20 X 1-1/2, FLANGE, CZ
25	5107336	1	ROD, DEFLECTOR SUPPORT 1/2 X 7.50
26	5107773	1	WELD, LEFT POWER DEFLECTOR, FB2000, CZ
27	5107771	1	WELD, LEFT SLAVE DEFLECTOR, FB2000,CZ
28	5025169	4	WASHER, 1/4" Lock
29	5106903	4	SCREW, 1/4-20 X 1-3/4, ALLEN, SS
30	5107339AA	2	WELD, UNIVERSAL DEFLECTOR GEAR - BLK
31	5107332AA	1	PLATE, DEFLECTOR SPACER - BLK
32	5107333	1	WELD, RACK KEEPER, CZ
33	5106872	2	BOLT, 1/4-20 X 3/4, SER FLG GD5, CZ (15102)
34	5107337	2	WELD, FORWARD DEFLECTOR PIN, CZ
35	5107493	1	WELD, RIGHT DEFLECTOR, X3, CZ
36	5107329A	1	PLATE,FW DEFLECTOR MOTOR MNT - BLK
37	5107260	1	CABLE,DEFLECTOR LCK PIN RETAIN
38	5025154	1	WASHER, 1/4 SAE
39	5107467	1	FORWARD DEFLECTOR X3, CZ
40	5106919	5	BOLT, 1/4-20 X 1-1/4, FLANGE, CZ
41	5106899	1	PIN, DEFELCTOR LOCK, CZ

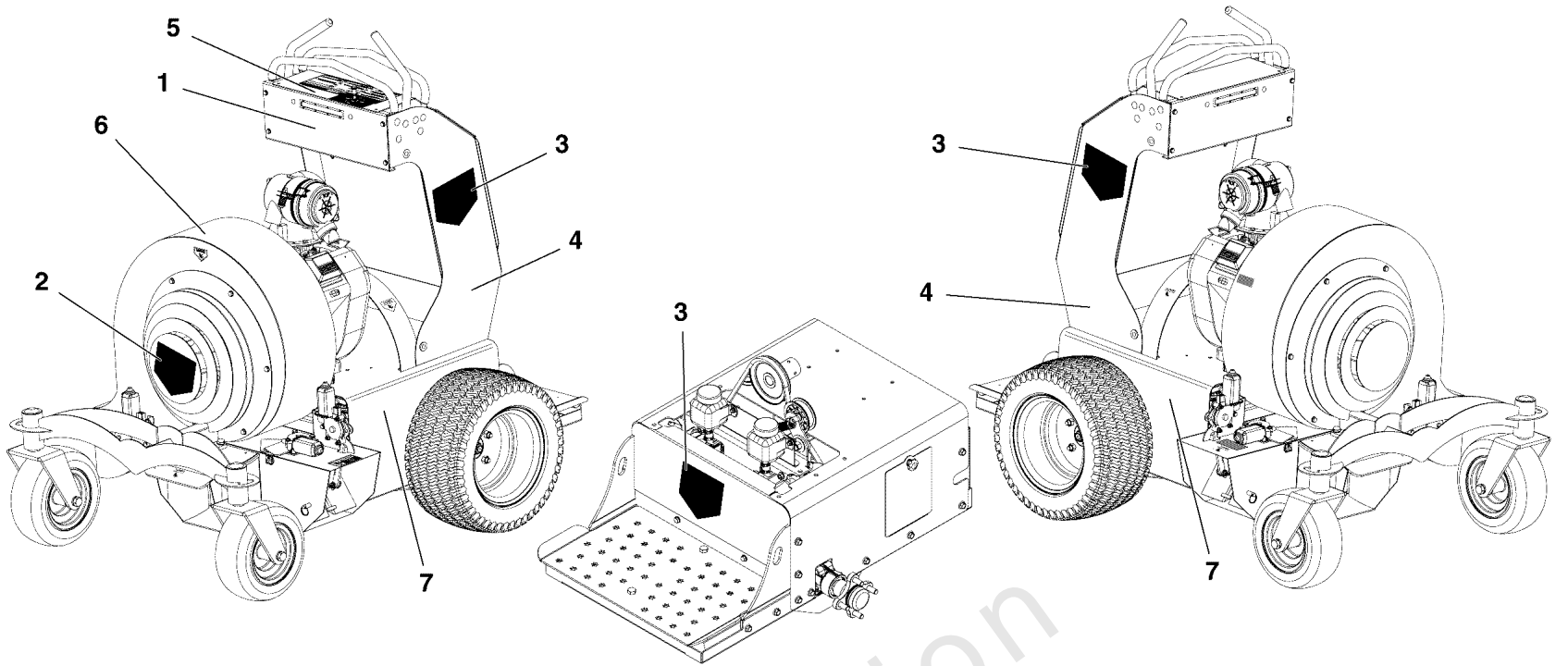

1 **FERRIS**

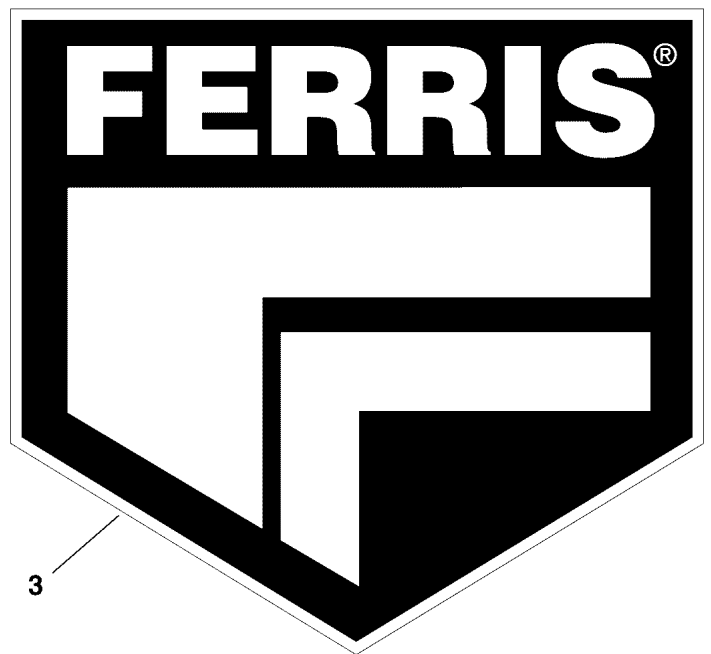
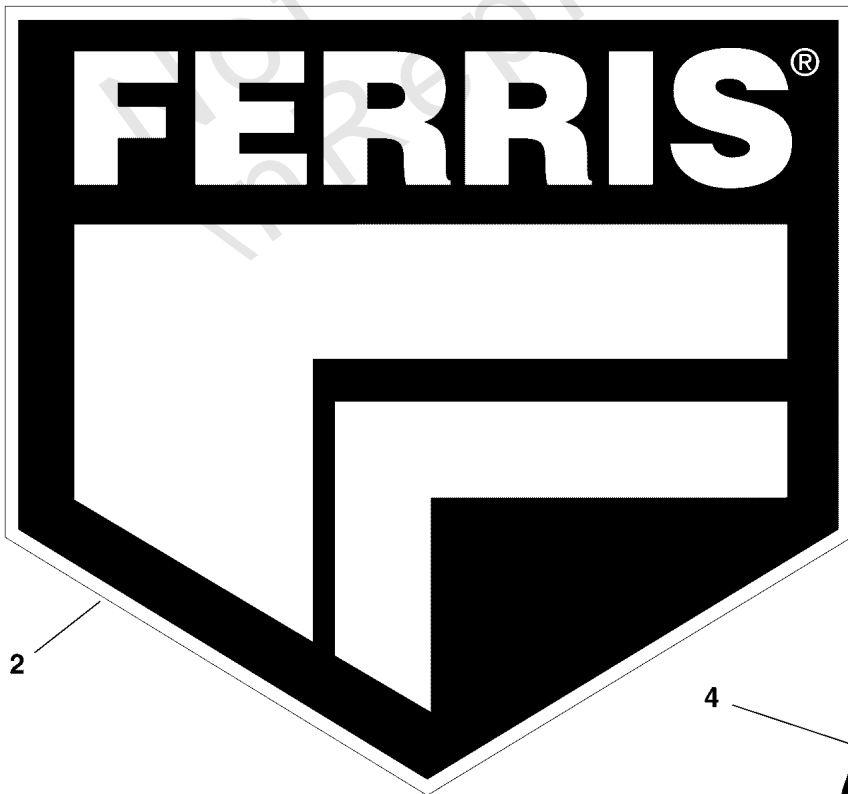

4 **FB2000**
HURRICANE



Decal Group - Brand and Model

REF NO	PART NO	QTY	DESCRIPTION
1	5107360	1	DECAL, FERRIS LETTER
2	5107431	1	DECAL, BLOWER HOUSING FRS SHIELD, FB2000
3	5107357	3	DECAL, FERRIS SHIELD LOGO
4	5107583	2	DECAL, FERRIS, FB2000 HURRICANE
5	5107362	1	DECAL, CONTROL PANEL FERRIS SHIELD
6	5106769	1	DECAL, ASSEMBLED IN THE USA
7	80082701	2	DECAL, POWERED BY VANGUARD

Not For InReproduction

Decal Group - Safety and Operational

Note: Unless noted otherwise, use the standard torque specifications

Mfg. No: 5901811

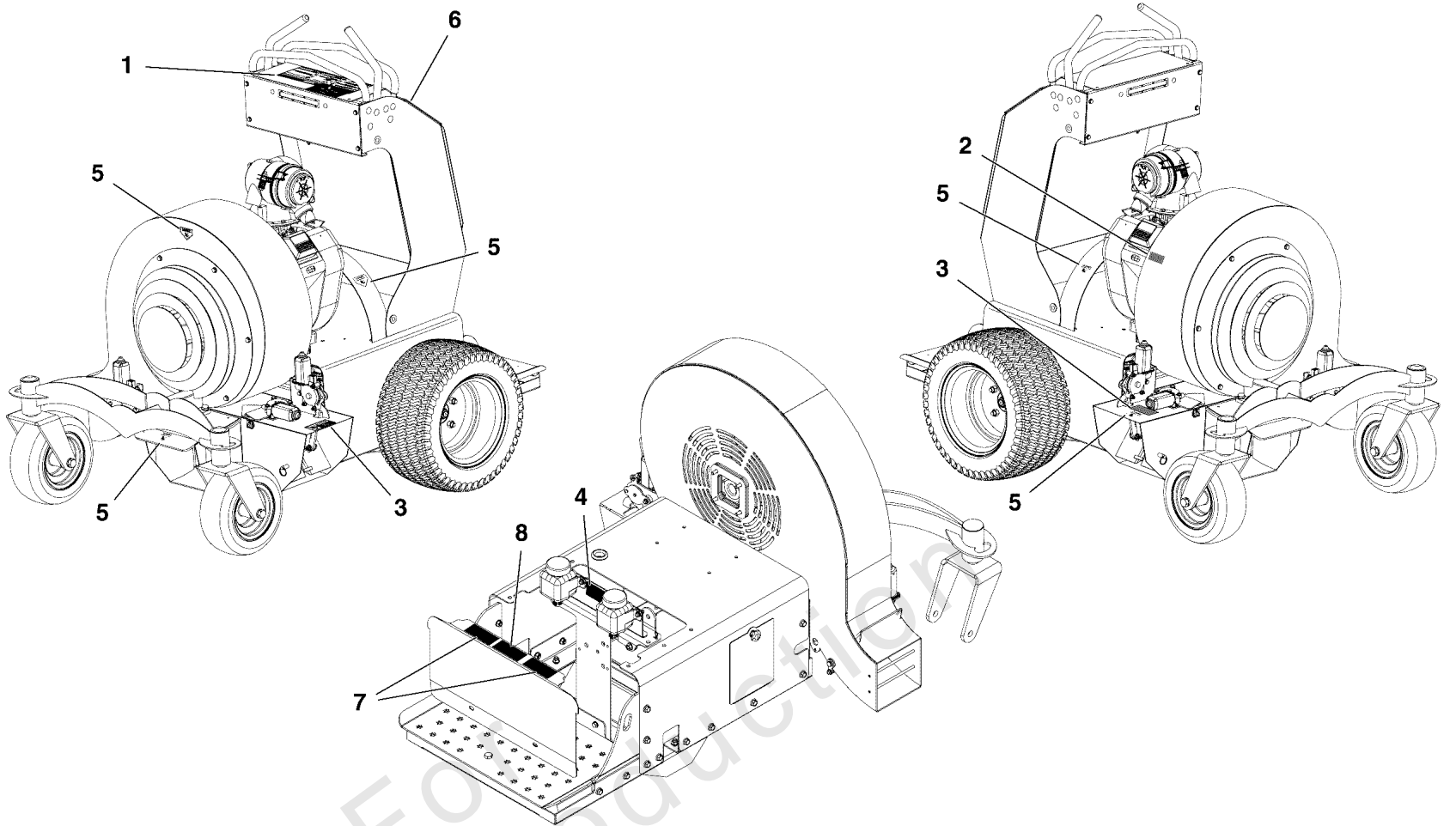

1

<p>OPEN</p> <p>OPEN</p> <p>OPEN</p> <p>CLOSE ALL</p>		
⚠ DANGER		
⚠ WARNING		
<p>⚠ WARNING: DO NOT SMOKE WHILE REFUELING. DO NOT FILL TANK WHILE ENGINE IS RUNNING OR WHILE ENGINE IS HOT.</p>	<p>⚠ WARNING: THROWN OBJECTS CAN CAUSE SERIOUS INJURY.</p>	<p>⚠ ALWAYS WEAR HEARING AND EYE PROTECTION.</p>
<p>⚠ DANGER: KEEP SHIELDS AND COVERS IN PLACE WHILE MACHINE IS IN OPERATION. KEEP HANDS AWAY FROM MOVING MACHINERY.</p>	<p>⚠ KEEP BYSTANDERS AWAY.</p>	<p>⚠ BEFORE PERFORMING ANY SERVICE OR MAINTENANCE, DISCONNECT SPARK PLUG WIRE. MAKE SURE THROTTLE IS IN STOP POSITION.</p>
<p>⚠ WARNING: IMPROPER USE OR CARE OF THIS BLOWER OR FAILURE TO WEAR PROPER PROTECTION CAN RESULT IN SERIOUS INJURY.</p>	<p>⚠ DANGER: KEEP HANDS AND FEET AWAY FROM INTAKE AND DISCHARGE AREA. ROTATING FAN WILL CAUSE SERIOUS INJURY.</p>	<p>⚠ USE EXTREME CAUTION OPERATING ON SLOPES. MOVE SLOWLY AND AVOID SUDDEN OR JERKY MOVEMENTS.</p>
<p>⚠ WARNING: TO PREVENT FIRE, KEEP ENGINE AND PUMP COMPARTMENTS CLEAN, ESPECIALLY IN EXHAUST AREA.</p>	<p>⚠ READ AND UNDERSTAND THE OWNER'S MANUAL. PAY PARTICULAR ATTENTION TO ALL SECTIONS REGARDING SAFETY.</p>	

3

⚠ CAUTION
PINCH POINT

7

TRANSAXLE BYPASS VALVE

PULL CABLE UP AND SIDWAYS TO ENGAGE BYPASS

⚠ DO NOT PUSH OR TOW MACHINE WITHOUT FIRST ENGAGING THE TRANSAXLE BYPASS. TRANSAXLE DAMAGE MAY OCCUR.

2

8

EMERGENCY BRAKE RELEASE

LIFT LEVER

XS-0211

5

⚠ DANGER

KEEP HANDS AND FEET AWAY

4

HYDROSTATIC OIL FILL

USE ONLY MOBIL 1 15W-50 SYNTHETIC

DO NOT OVERFILL

6

FORWARD

REVERSE

FUEL FILL (GASOLINE ONLY)

OIL ALERT

FORWARD

REVERSE

THROTTLE

THROTTLE

PARKING BRAKE

RED DOTTED LINE = BRAKE AUTOMATICALLY ENGAGED

GRAY FILL = BRAKE AUTOMATICALLY DISENGAGED

Decal Group - Safety and Operational

REF NO	PART NO	QTY	DESCRIPTION
1	5107509	1	DECAL, DASH, JOYSTICK
2	5106771	1	DECAL, HOT
3	5106773	2	DECAL, PINCH
4	5106774	1	DECAL, HYDRO
5	5106775	5	DECAL, DANGER
6	5106776	1	DECAL, DASH CONTROLS
7	5106777	2	DECAL, TRANS BYPASS
8	5106778	1	DECAL, EMERGENCY BRAKE

Not For In Reproduction

Electrical Group

Note: Unless noted otherwise, use the standard torque specifications

Mfg. No: 5901811

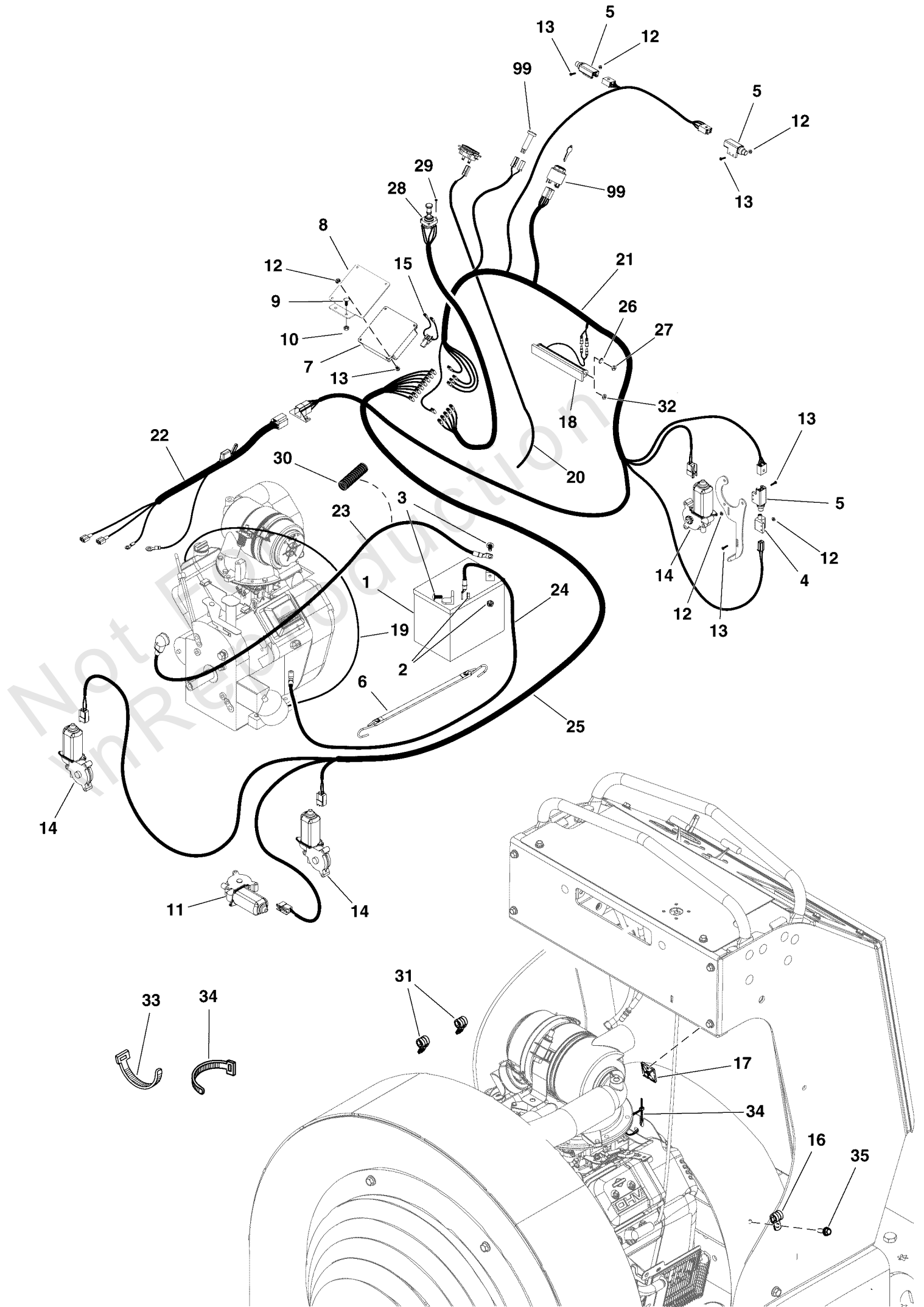

Electrical Group

REF NO	PART NO	QTY	DESCRIPTION
1	REF-BATT	1	BATTERY -(12 volt, 230 CCA)
2	5025127	2	NUT, 5/16-18 HEX SERRATED FLANGE (SMALL)
3	80003531	2	SCREW, 5/16-18X0.750, GR5, WHIZ-LOCK, ZC
4	5021769	1	SWITCH, PLUNGER, N.C.
5	5106950	3	SWITCH, SAFETY(2P)
6	5106918	1	STRAP, BATTERY
7	5106791	1	RELAY, CONTROL MODULE
8	5107407AA	1	BRACKET, RELAY MOUNT - BLK
9	80003518	2	BOLT, 1/4-20X0.750, GR5, STD NECK, SQ, ZC/CL
10	5025126	4	NUT, Hex, Serrated Flange, 1/4-20
11	5106953	1	MOTOR, DEFLECTOR, LEFT
12	80013127	12	NUT, #10-32, HEX, KEPS, ZC/CL
13	5106875	12	SCREW, #10-32 X 3/4, ALLEN, SS
14	5106952	3	MOTOR, DEFLECTOR, RIGHT
15	5107310	1	CIRCUIT BREAKER, 15A A-RESET
16	5107053	1	CLAMP, VINYL INSULATED, .50
17	5107270	2	MOUNT, ZIPTIE, X3
18	5420644	1	HEADLIGHT, DEBRIS BLOWER
19	5107888	1	WIRE HARNESS, OIL PRESSURE SWITCH, X3
20	5107043	1	WIRE HARNESS, TACH X3, Z3 -(End without terminal is wrapped around spark plug wire and secure with wire tie.)
21	5107275	1	WIRE HARNESS, MAIN, X3 JOYSTICK
22	5107272	1	WIRE HARNESS, VANGUARD 23HP
23	5107244	1	BATTERY CABLE, POS, 24.69, 5/16-5/16
24	5107245	1	BATTERY CABLE, NEG, 13.50, 5/16-3/8
25	5107276	1	WIRE HARNESS, DEFLECTOR, X3 JOYSTICK
26	5025673	2	WASHER, 5MM, STAR, CZ -(For headlights with 5MM studs)
27	5025672	2	NUT, HEX, M5X.8MM, NYLON INSERT -(For headlights with 5MM studs)
28	5107309	1	ASSM, JOYSTICK
29	5106917	4	SCREW, #8-32 X 3/8, ALLEN, SS
30	5050927X17P5	2	WIRE LOOM, 3/8 ID X 17.5 IN
31	5107987	2	CLAMP, VINYL INSULATED, .75
32	5025669	2	NUT, HEX, M6-1, NYLON INSERT -(For headlights with 6MM studs)
33	5021029	3	TIE, SELF-LOCKING, 12"
34	5021030	9	TIE, SELF-LOCKING, 6"
35	5106872	2	BOLT, 1/4-20 X 3/4, SER FLG GD5, CZ (15102)
99	-----	0	Refer to: Instrument Control Panel Group

Electrical Schematic

Note: Unless noted otherwise, use the standard torque specifications

Mfg. No: 5901811

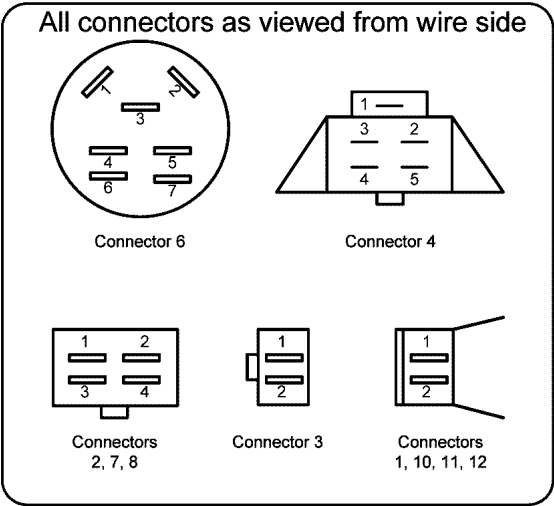
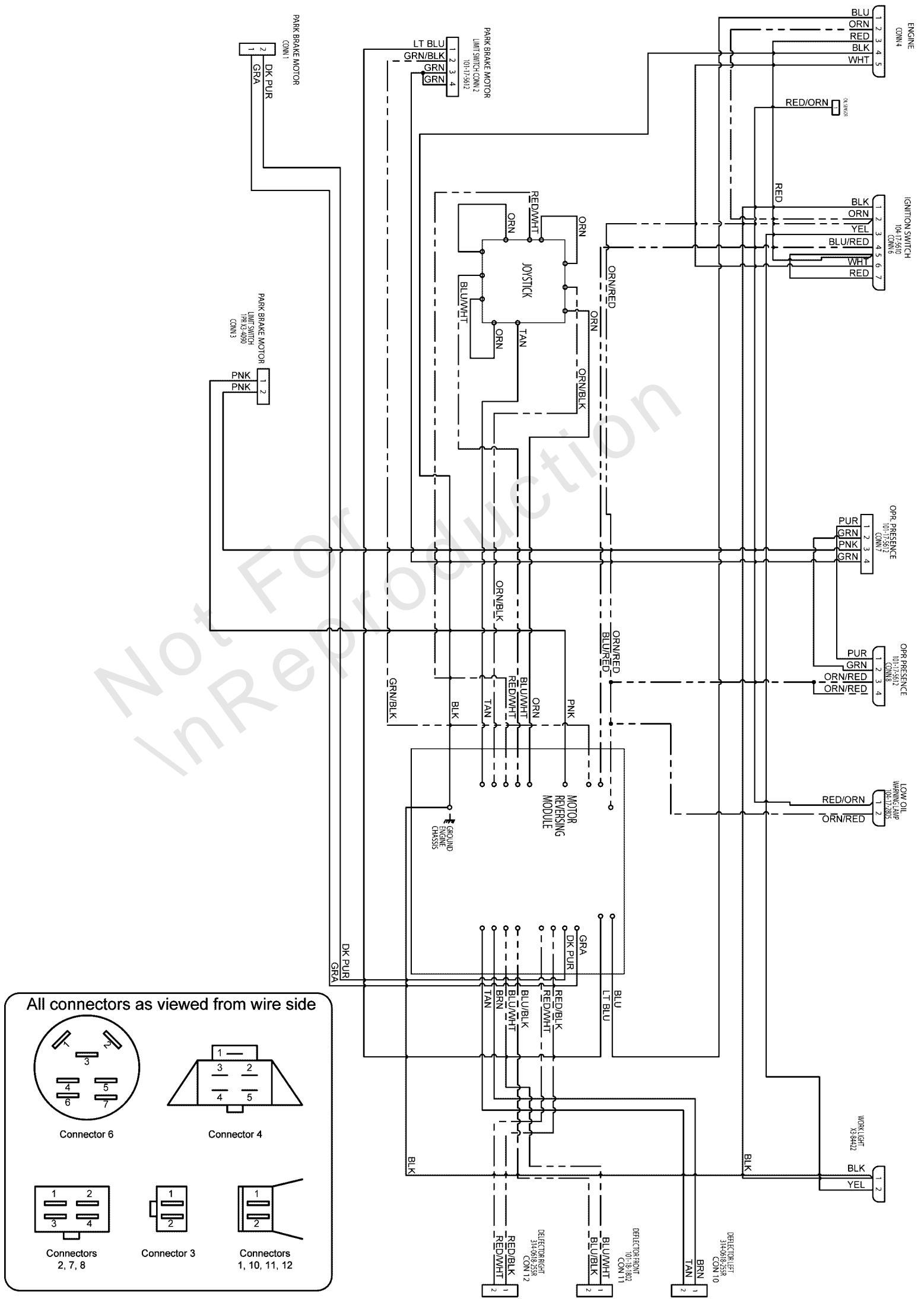

Electrical Schematic

REF NO	PART NO	QTY	DESCRIPTION
1	5107888	1	WIRE HARNESS, OIL PRESSURE SWITCH,X3
2	5107043	1	WIRE HARNESS, TACH X3,Z3
3	5107272	1	WIRE HARNESS,VANGUARD 23HP
4	5107276	1	WIRE HARNESS, DEFLECTOR, X3 JOYSTICK
5	5107275	1	WIRE HARNESS, MAIN, X3 JOYSTICK

Not For InReproduction

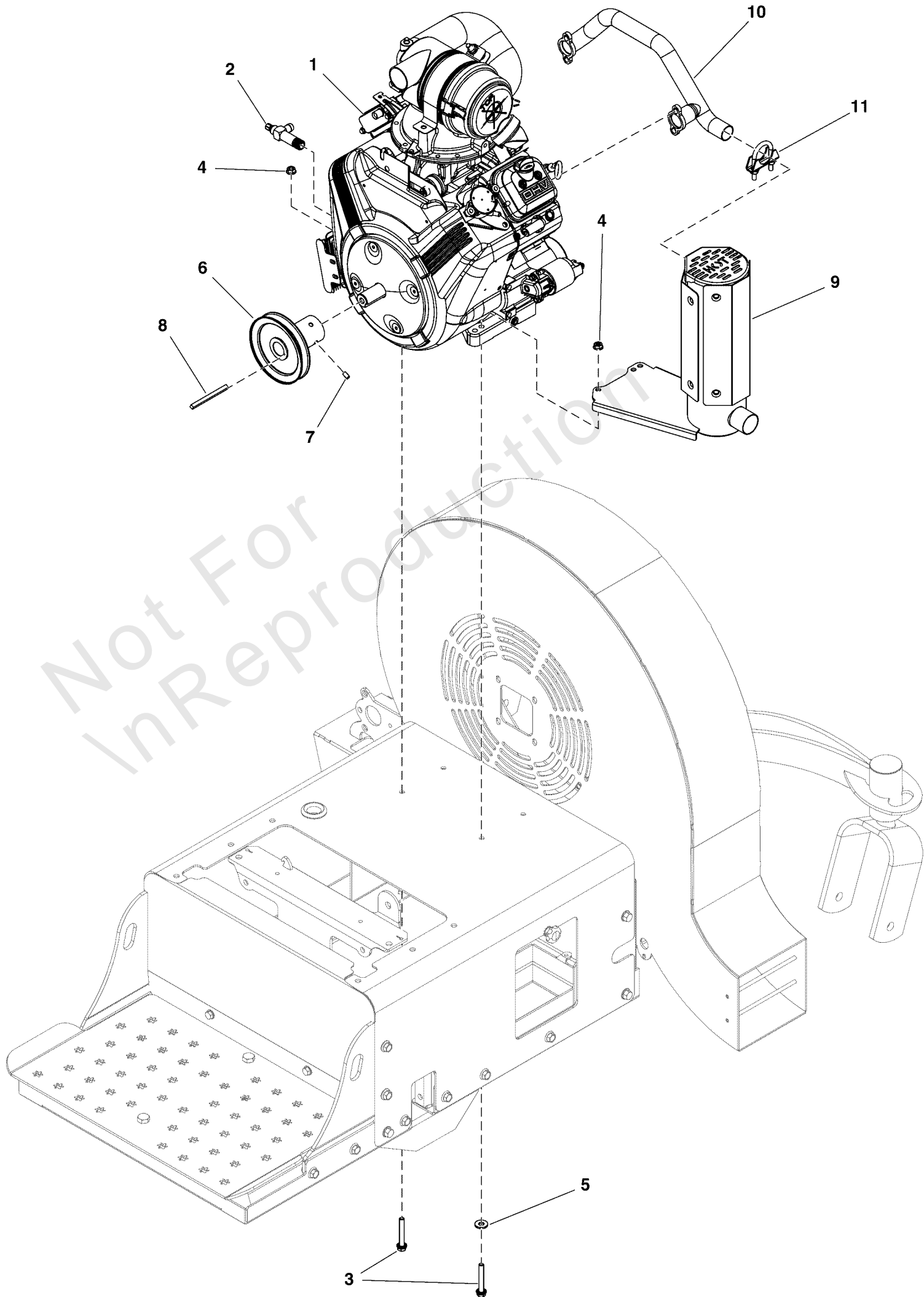

Engine Group

REF NO	PART NO	QTY	DESCRIPTION
1	386447-0403-G1	1	ENGINE, VANGUARD, 23
2	5107284	1	VALVE, OIL DRAIN
3	5107304	4	BOLT, 5/16-18 X 2-1/4, SER FLNG GD5, CZ
4	5025127	4	NUT, 5/16-18 HEX SERRATED FLANGE (SMALL)
5	5025337	1	WASHER, 5/16" USS
6	5107464	1	PULLEY, DRIVE, X3
7	5107269	2	SET SCREW, 1/4-20 X 1/2, BLK
8	5106925	1	KEY, 1/4SQ X 3-3/8
9	5107050	1	MUFFLER, MINI
10	5107049	1	MANIFOLD, 1-1/8" W/ FLNGS
11	5107405	1	CLAMP, 1-1/4 MUFFLER CLAMP

Not For InReproduction

Fuel Tank and Hose Group

REF NO	PART NO	QTY	DESCRIPTION
1	5107316	1	FUEL CAP, 2.0, NON VENTED
2	5418869	1	WELD, FUEL TANK, BLOWER
3	5106863	4	SCREW, 1/4-20 X 3/4, FPHMS, SS
4	5025126	4	NUT, Hex, Serrated Flange, 1/4-20
5	5050831X6	2	HOSE, 1/4" FUEL, 6" LONG
6	5107072	1	VALVE, FUEL SHUT OFF
7	5107073	1	PICKUP TUBE ASM,FUEL 16.75
8	5106957	1	FITTING, 1/4X3/16 REDUCER -(For units with 1/4" hose.)
9	5106956	1	FITTING, 1/4 TEE, BARB TYPE
10	5106954	1	FITTING, 90, 1/4-18 NPT NYLON
11	7700552X2P5	2	HOSE, VAPOR, 5MM ID, 2.50 LG
12	80025019	1	FILTER, FUEL
13	5106955	1	CHECK VALVE ASMY
14	7700552X4	1	HOSE, VAPOR, 5MM ID, 4.00 LG
15	93807	4	CLAMP, Hose
16	5021030	1	TIE, SELF-LOCKING, 6"
17	7700552X6	1	HOSE, Vapor, 5 MM ID, 6.00 LG

Handle Bar Group

Note: Unless noted otherwise, use the standard torque specifications

Mfg. No: 5901811

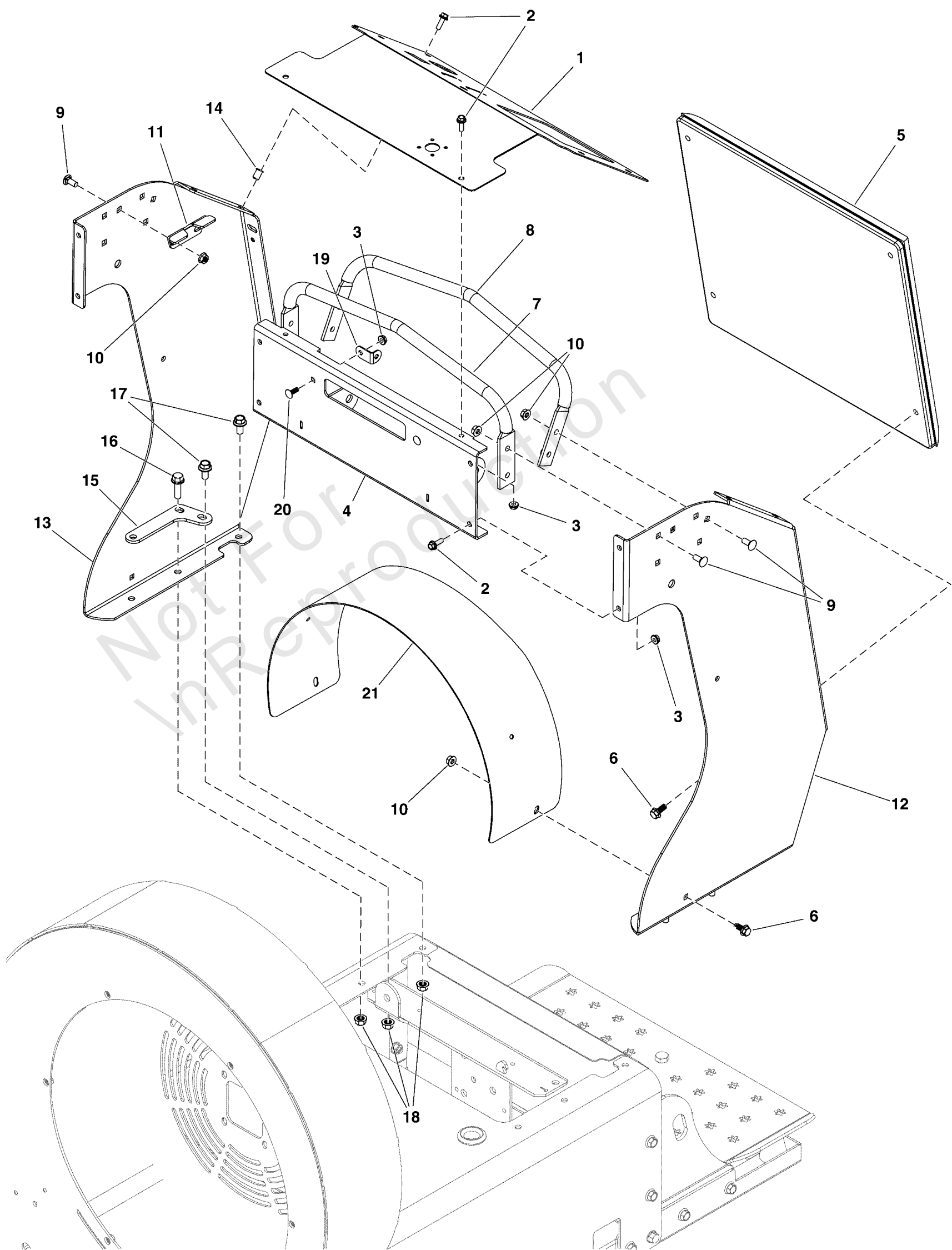

Handle Bar Group

REF NO	PART NO	QTY	DESCRIPTION
1	5418514AA	1	PLATE, DASH PANEL, X3,Z3 - BLK
2	5106872	10	BOLT, 1/4-20 X 3/4, SER FLG GD5, CZ (15102)
3	5025126	10	NUT, Hex, Serrated Flange, 1/4-20
4	5418513AI	1	WELD, DASH FRONT PANEL - RED
5	5107538	1	KNEE PAD, BLWR
6	80003531	6	SCREW, 5/16-18X0.750, GR5, WHIZ-LOCK, ZC
7	5107044A	1	FRONT HANDLE, BLWR - BLK
8	5107045A	1	REAR HANDLE, BLWR - BLK
9	5025145X6	12	BOLT, 5/16-18 X 3/4, CARRIAGE, GD5, CZ
10	5025127	14	NUT, 5/16-18 HEX SERRATED FLANGE (SMALL)
11	5107391	2	BRACKET, NEUTRAL CENTERING, CZ
12	5418516AI	1	CONTROL TOWER X3, LH - RED
13	5418515AI	1	CONTROL TOWER X3, RH - RED
14	5106833	4	NUT, 1/4-20, RIV, CZ
15	5107437A	2	PLATE, UPPER BEAM MOUNT - BLK
16	5025390X8	4	BOLT, Flange, 3/8-16 X 1
17	5025390X8	4	BOLT, Flange, 3/8-16 X 1
18	5025666	8	NUT, 3/8-16, FLANGE, SERRATED UNDER HEAD
19	5107389AA	2	BRACKET, L HEADLIGHT MOUNT - BLK
20	80003518	2	BOLT, 1/4-20X0.750,GR5,STD NECK,SQ,ZC/CL
21	5418518AI	1	PLATE, BELT GUARD X3 - RED

Hydraulic Group

REF NO	PART NO	QTY	DESCRIPTION
1	5107366AA	1	MOUNT, OIL RESERVOIR - BLK
2	5100473	2	RESERVOIR, HYDRO OIL, 350 ML
3	5106872	6	BOLT, 1/4-20 X 3/4, SER FLG GD5, CZ (15102)
4	5025126	6	NUT, Hex, Serrated Flange, 1/4-20
5	5025474	4	CLAMP, HOSE, .75 FREE DIA.
6	5050857X1P75	2	HOSE, 1/2" PUSH-ON, 1.75"
7	5107224	2	FITTING, STRAIGHT 7/16-20 UNF (HU002)
8	5107235	2	CABLE, HYDRO NEUTRAL RELEASE -(Includes item #24)
9	5025667	1	BOLT, HEX, 3/8-16 X 10" GD 5, CZ
10	5025156	1	WASHER, 3/8 SAE
11	5107370	1	SPACER, .75 OD X 6.40 LONG, 10GA (X3-1436)
12	5107188	1	TRANSAXLE, ZT3100, RH, ZJ-LCRP-3A7C-19XX
13	5107186	1	TRANSAXLE, ZT3100, LH, ZJ-HCRP-3A7B-19XX
14	5025670	4	BOLT, HEX, 3/8-16 X 3", SER FLG GRD5, CZ
15	5025666	4	NUT, 3/8-16, FLANGE, SERRATED UNDER HEAD
16	5106813	1	BELT, A-SEC, 47.15, RAW EDGE
17	5106923	1	SPRING, IDLER, #98 (16127)
18	5025017X16	2	BOLT, 1/2-13 X 2" GD5 CZ
19	5107103	1	PULLEY IDLER 3.0 OD .506ID .75 (17-4101)
20	5025396	1	NUT, Hex Flange, Nylock, 1/2-13
21	5107365AA	1	IDLER ARM - BLK
22	5025056	1	NUT, Hex, Nylon Lock, 1/2-13
23	5107348	4	WASHER, 0.54 X 1.50 X 0.060, CZ
24	5106888	2	SPRING, EXTENSION, #29
25	5108012	2	KEY RING, SPLIT 1"
26	5025394	5	NUT, 3/8 - 16 HEX NYLOCK FLANGE
27	5106859	4	BOLT, 3/8-16 X 2-1/2, SER FLG GD5, CZ (15087)

Instrument Control Panel Group

Note: Unless noted otherwise, use the standard torque specifications

Mfg. No: 5901811

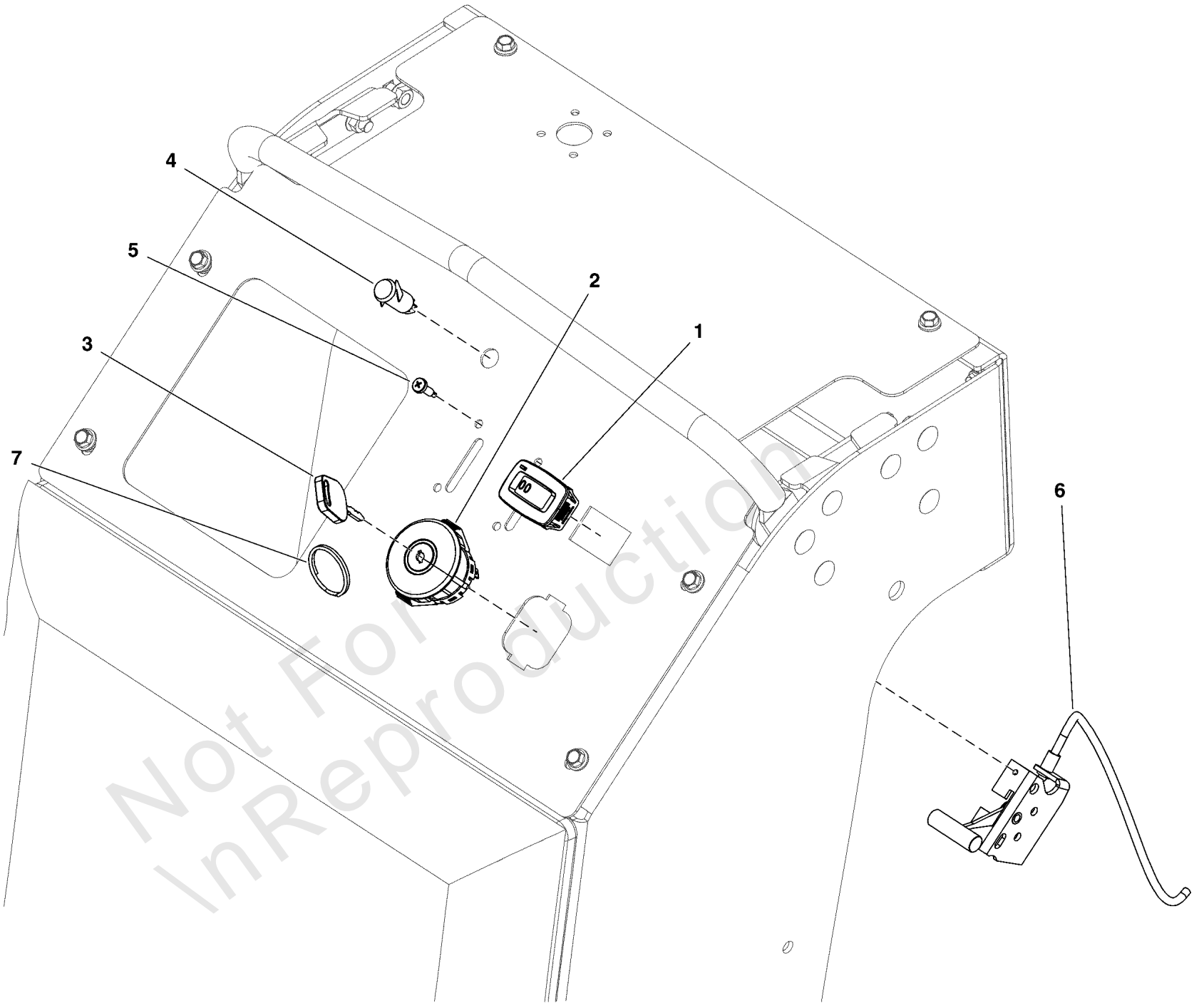

Instrument Control Panel Group

REF NO	PART NO	QTY	DESCRIPTION
1	5106789	1	HOUR, METER & TECH
2	5107021	1	SWITCH, IGNITION, SNAP-IN
3	1714054	2	KEY, Ignition
4	5106974	1	LIGHT, WARNING
5	5106862	4	SCREW, #10-16 X 1/2, SLF DRLNG, CZ
6	5107194	2	CABLE, THROTTLE/CHOKE
7	5108012	1	KEY RING, SPLIT 1" -(Key Ring for ignition keys)

Not For In Reproduction

Main Frame Group

Note: Unless noted otherwise, use the standard torque specifications

Mfg. No: 5901811

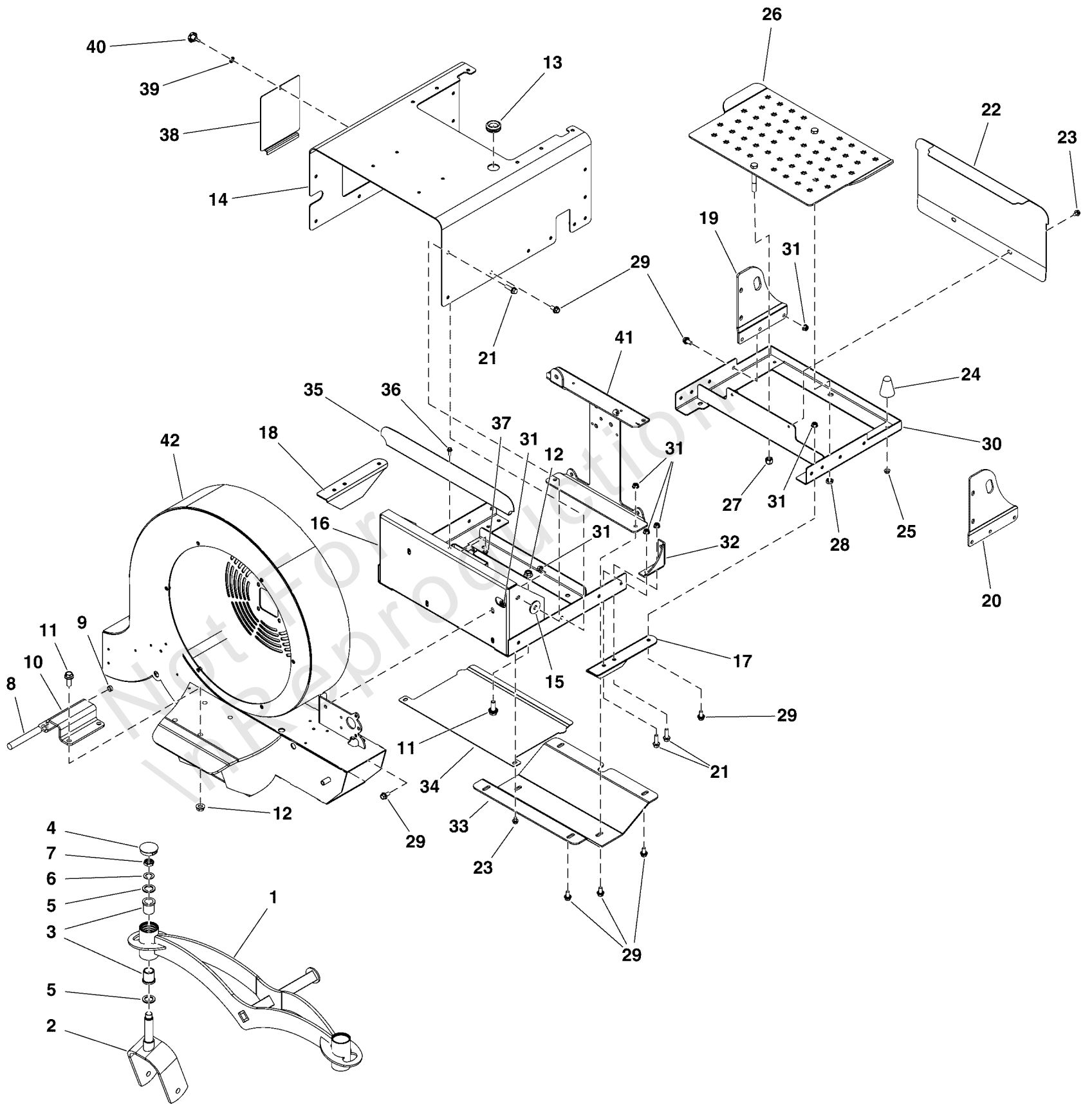

Main Frame Group

REF NO	PART NO	QTY	DESCRIPTION
1	5418608AI	1	WELD, FRONT END PIVOT, X3 - RED
2	5418604AI	2	WELD, CASTER FORK, X3 - RED
3	5021541	4	BUSHING, FLANGE
4	5107567	2	CAP, GREASE, PLASTIC
5	5107778	4	WASHER, 1 X 10GA, MACH, CZ
6	5107779	2	WASHER, 3/4 X 14GA, MACH, CZ
7	5106783	2	NUT, 3/4-10, NYLOCK JAM, CZ
8	5107356	4	CORD, RUBBER
9	-----	2	RUBBER BAND -(Rubber Band is used to hold the four pieces of #8 together.)
10	5419091AI	1	PLATE, FRONT END TORSION C - RED
11	5106786	6	BOLT, 1/2-13 X 1-1/4, FLANGE, CZ
12	5106787	6	NUT, 1/2-13, SER FLG, CZ (15046)
13	5106788	1	GROMMET, RUBBER
14	5418509AI	1	WELD, MOTOR BOX - RED
15	5107390	2	SPACER, MOTOR BOX 10GA
16	5107435A	1	WELD, X3 FRONT CHASSIS - BLK
17	5107383A	1	BRACKET, BOTTOM CHASSIS LEFT - BLK
18	5107382A	1	BRACKET, BOTTOM CHASSIS RIGHT - BLK
19	5418520AI	1	PLATE, TIE DOWN RH - RED
20	5418521AI	1	PLATE TIE DOWN LH - RED
21	5025390X10	10	BOLT, 3/8-16 X 1-1/4, FLANGE, GD 5, CZ
22	5419300AI	1	PLATE, TOE KICK, FB2000 - RED
23	5106898	4	SCREW, 5/16-18 X 1/2, SLF TPNG, CZ
24	5107206	4	BUMPER, RUBBER, 5/16-18
25	5025127	4	NUT, 5/16-18 HEX SERRATED FLANGE (SMALL)
26	5418525A	1	WELD, PLATFORM, BLWR - BLK
27	5025056	1	NUT, Hex, Nylon Lock, 1/2-13
28	5025646	1	NUT, NTE, 1/2-13, CZ
29	5106881	28	BOLT, 3/8-16 X 3/4, SER FLG GD5, CZ (15112)
30	5107434A	1	WELD, X3 REAR CHASSIS - BLK
31	5025666	38	NUT, 3/8-16, FLANGE, SERRATED UNDER HEAD
32	5107387A	2	WELD, TRANS 90 DEG MOUNT BRACKET - BLK
33	5107384A	1	PLATE, SKID - BLK
34	5107385A	1	GUARD, LOWER DEBRIS - BLK
35	5107386A	1	GUARD, FORWARD DEBRIS - BLK
36	5106872	2	BOLT, 1/4-20 X 3/4, SER FLG GD5, CZ (15102)
37	5025126	2	NUT, Hex, Serrated Flange, 1/4-20
38	5419192AI	1	PLATE, BATTERY DOOR - RED
39	5107350	1	WASHER, INT / EXT TOOTH, CZ
40	5106913	1	KNOB, 1/4-20 X 1/2 CAP SCREW
41	5107388A	1	WELD TRANS I-BEAM - BLK
42	5418641AI	1	WELD, BLOWER HOUSING , X3 - RED

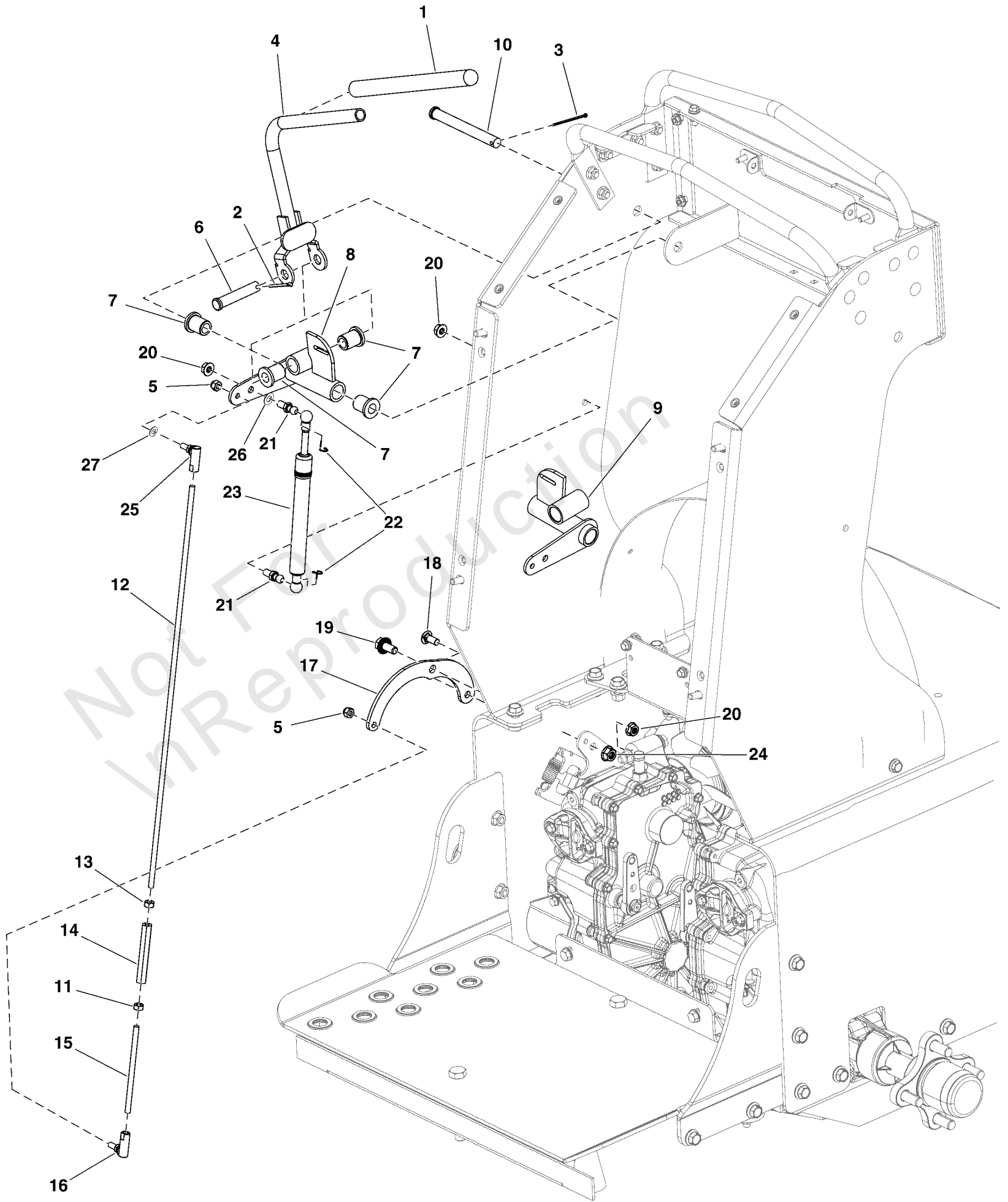

Motion Control Group

REF NO	PART NO	QTY	DESCRIPTION
1	5106940	2	GRIP CONTROL 9-1/2 (139530)
2	5025203X12	2	PIN, COTTER, 1/8 X 1 1/2, CZ
3	5107351	2	PIN, COTTER, 3/32 X 2.00, CZ
4	5107368	2	WELD, CONTROL HANDLE (14-40-2011)
5	5106892	4	NUT, 1/4-28, NYLOCK, GD2 CZ (15140)
6	5022044	2	PIN-CLEVIS, 1/2 X 2-1/2 YZP
7	5106943	8	BUSHING, 1/2 X 3/4 X 1F (0117-081216)
8	5107369	1	WELD, CONTROL SWITCH BRACKET LH (X3-1438)
9	5107367	1	WELD, CONTROL SWITCH BRACKET RH (X3-1437)
10	5025456	2	PIN CLEVIS 1/2" X 4-1/2" PLT
11	5106853	2	NUT, 1/4-28, RH, GD5 CZ (15081)
12	5107108	2	ROD, 1/4-28 x 21" YZ (2500-2100)
13	5106858	2	NUT, 1/4-28, LH, YZ (15086)
14	5106971	2	TURNBUCKLE, 1/4-28 X 3 (103-17-4635)
15	5107303	2	ROD 1/4-28 X 4-1/2" YZ (ZP16054)
16	5106802	2	BALL JOINT, 1/4"-28 THREAD LH
17	5107241	2	ARM, TRANSMISSION CONTROL (X3-1520)
18	5025145X6	2	BOLT, 5/16-18 X 3/4, CARRIAGE, GD5, CZ
19	5106881	2	BOLT, 3/8-16 X 3/4, SER FLG GD5, CZ (15112)
20	5025127	6	NUT, 5/16-18 HEX SERRATED FLANGE (SMALL)
21	5100941	4	BALL STUD, 5/16 X .50,# PC-477-2)
22	5106969	4	CLIP, DAMPER BALL STUD (103-17-4431)
23	5107193	2	DAMPER (425-103-174430)
24	5025666	2	NUT, 3/8-16, FLANGE, SERRATED UNDER HEAD
25	5106803	2	BALL JOINT, 1/4-28 RH STUD
26	5025155	2	WASHER, 5/16" SAE
27	5025154	2	WASHER, 1/4 SAE

Parking Brake Group

Note: Unless noted otherwise, use the standard torque specifications

Mfg. No: 5901811

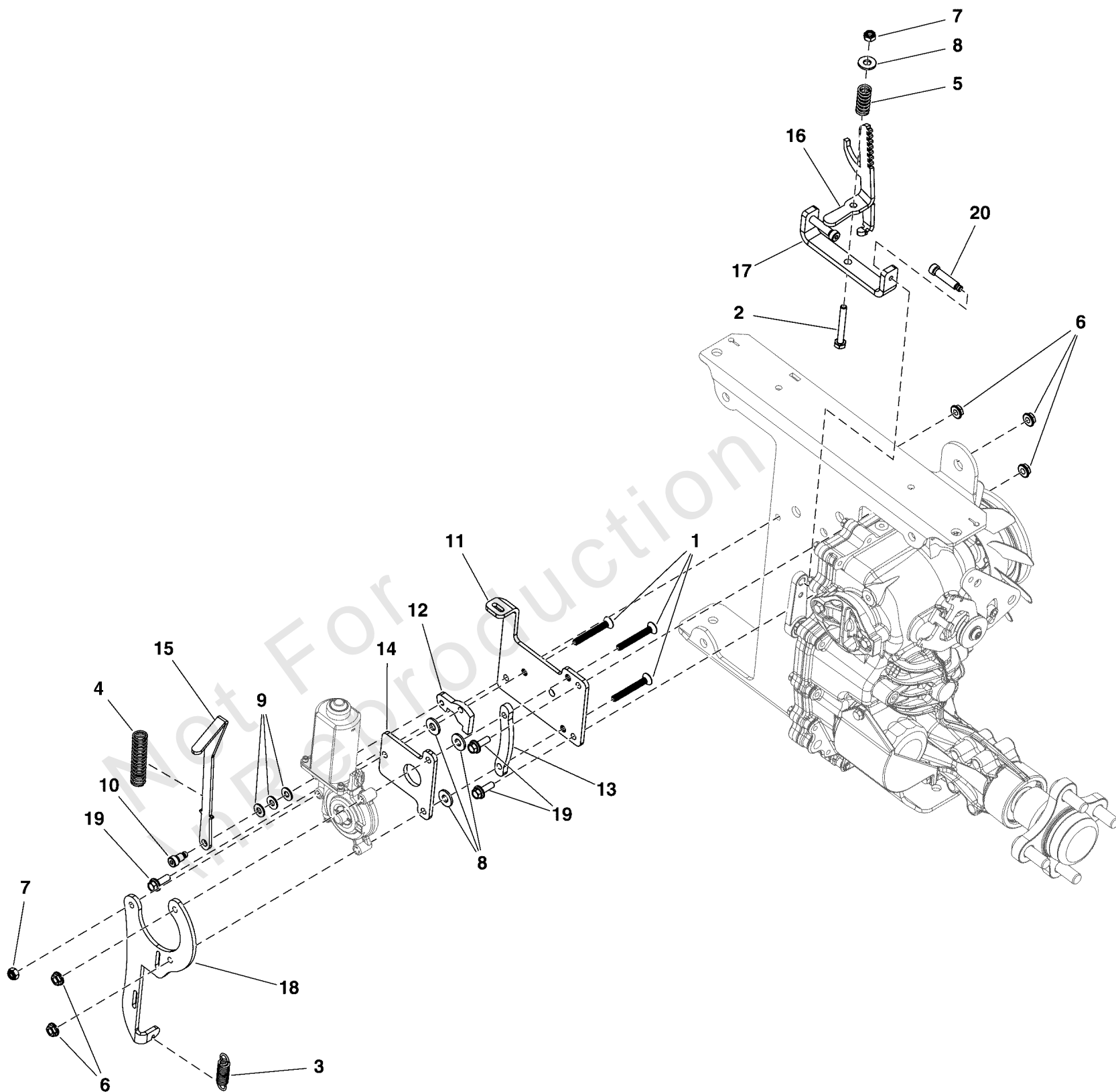

Parking Brake Group

REF NO	PART NO	QTY	DESCRIPTION
1	5106908	3	SCREW, 1/4-20 X 2, PHLPS, SS
2	5025010X16	1	BOLT, 1/4-20 X 2", GD5
3	5106888	1	SPRING, EXTENSION, #29
4	5106910	1	SPRING, COMPRESSION, #29
5	5106911	1	SPRING, COMPRESSION, #21
6	5025126	5	NUT, Hex, Serrated Flange, 1/4-20
7	5025095	2	HUT, HEX NYLON LOCK, 1/4x20"
8	5106815	4	WASHER, 1/4 SAE, CZ
9	5025154	3	WASHER, 1/4 SAE
10	5106912	1	BOLT, 5/16 X 1/2, SHLDR, SS
11	5107321	1	PLATE, BRAKE BACKING
12	5107322	1	PLATE, BRAKE CAM, CZ
13	5107323AA	1	PLATE, BRAKE SPACER - BLK
14	5107324	1	PLATE, CAM COVER, CZ
15	5107328	1	PLATE, BRAKE RELEASE LEVER,CZ
16	5107325	1	WELD, BRAKE GEAR RACK,CZ
17	5107326	1	PLATE, BRAKE LEVER ARM
18	5107327	1	PLATE, SWITCH MOUNT, CZ
19	5106872	3	BOLT, 1/4-20 X 3/4, SER FLG GD5, CZ (15102)
20	5106941	2	BOLT, 5/16 X 1-1/4, SHLDR, SS

Wheel and Tire Group

Note: Unless noted otherwise, use the standard torque specifications

Mfg. No: 5901811

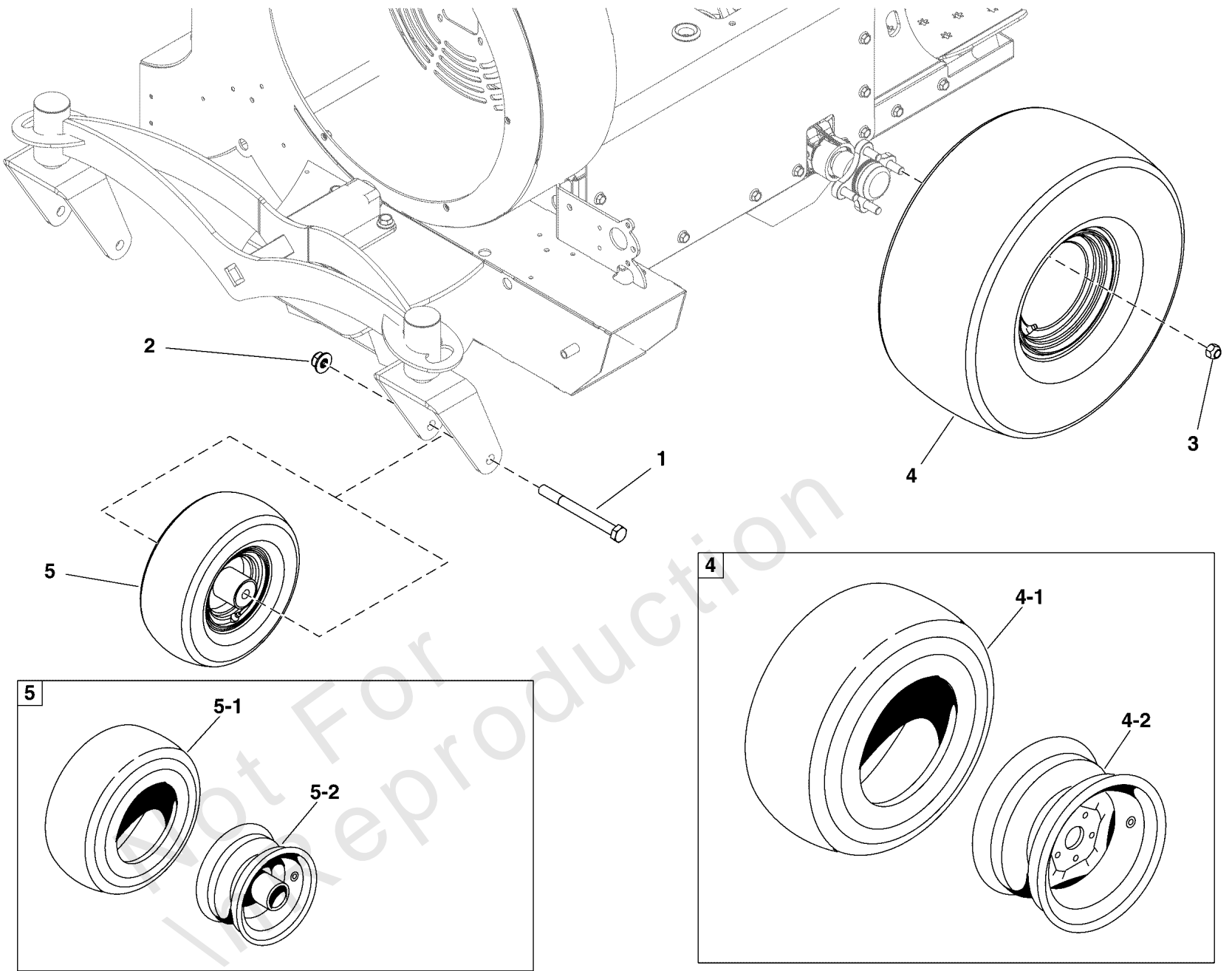

Wheel and Tire Group

REF NO	PART NO	QTY	DESCRIPTION
1	5106896	2	BOLT, 5/8-11 X 6-1/2, CZ
2	5025403	2	NUT, 5/8-11 HEX NYLOCK FLANGE
3	5020601	8	NUT, 1/2-20, FOR WHEEL BOLT SILVER -(Torque lug nuts to 90 ft-lbs (122Nm))
4	5107874	2	TIRE/WHEEL ASM, 20 X 8.00-8, TURF
4-1	5107874X1	2	TIRE, 20-8 x 8 4PLY (TIRE ONLY) -(One per tire)
4-2	5107874X2	2	WHEEL, 8 X 6.125 BW, 4 ON 4BC, RIM ONLY -(One per tire)
5	5107877	2	TIRE ASSEMBLY, 11 X 4.00 - 5
5-1	5107877X1	2	TIRE, 11-4 X 5, 4PLY, TIRE ONLY -(One per tire)
5-2	-----	2	WHEEL, RIM -(Not available for sale. Refer to Complete Tire Assembly)
5-3	5107877X3	4	5/8 X 1-3/8 DOUBLE SEALED FLANGED BB -(Two per tire)

Not For In-Production

Hardware Identification & Torque Specifications

Torque Specification Chart								
FOR STANDARD METRIC MACHINE HARDWARE (Tolerance ± 20%)								
Property Class	5.6		8.8		10.9		12.9	
	Class 5.6		Class 8.8		Class 10.9		Class 12.9	
Size Of Hardware	in/lbs	Nm.	in/lbs	Nm.	in/lbs	Nm.	in/lbs	Nm.
	ft/lbs		ft/lbs		ft/lbs		ft/lbs	
M3	5.88	.56	13.44	1.28	19.2	1.80	22.92	2.15
M4	13.44	1.28	30.72	2.90	43.44	4.10	52.56	4.95
M5	26.4	2.50	60.96	5.75	5.97	8.10	7.15	9.7
M6	44.64	4.3	7.3	9.9	10.3	14	12.1	16.5
M7	5.2	7.1	12.1	16.5	16.9	23	19.9	27
M8	7.7	10.5	17.7	24	25	34	29	40
M10	15	21	35	48	50	67	59	81
M12	26	36	61	83	86.2	117	103	140
M14	42	58	101	132	136	185	162	220
M16	64	88	147	200	210	285	250	340
M18	89	121	202	275	287	390	346	470
M20	126	171	290	390	405	550	486	660
M22	169	230	390	530	559	745	656	890
M24	217	295	497	375	708	960	840	1140
M27	320	435	733	995	1032	1400	1239	1680
M30	435	590	995	1350	1401	1900	1681	2280
M33	590	800	1349	1830	1902	2580	2278	3090
M36	759	1030	1740	2360	2441	3310	2935	3980
M39	988	1340	2249	3050	3163	4290	3798	5150

Torque Specification Chart						
FOR STANDARD MACHINE HARDWARE (Tolerance ± 20%)						
Hardware Grade	No Marks		SAE Grade 5		SAE Grade 8	
	SAE Grade 2		SAE Grade 5		SAE Grade 8	
Size Of Hardware	in/lbs	Nm.	in/lbs	Nm.	in/lbs	Nm.
	ft/lbs		ft/lbs		ft/lbs	
8-32	19	2.1	30	3.4	41	4.6
8-36	20	2.3	31	3.5	43	4.9
10-24	27	3.1	43	4.9	60	6.8
10-32	31	3.5	49	5.5	68	7.7
1/4-20	66	7.6	8	10.9	12	16.3
1/4-28	76	8.6	10	13.6	14	19.0
5/16-18	11	15.0	17	23.1	25	34.0
5/16-24	12	16.3	19	25.8	29	34.0
3/8-16	20	27.2	30	40.8	45	61.2
3/8-24	23	31.3	35	47.6	50	68.0
7/16-14	30	40.8	50	68.0	70	95.2
7/16-20	35	47.6	55	74.8	80	108.8
1/2-13	50	68.0	75	102.0	110	149.6
1/2-20	55	74.8	90	122.4	120	163.2
9/16-12	65	88.4	110	149.6	150	204.0
9/16-18	75	102.0	120	163.2	170	231.2
5/8-11	90	122.4	150	204.0	220	299.2
5/8-18	100	136	180	244.8	240	326.4
3/4-10	160	217.6	260	353.6	386	525.0
3/4-16	180	244.8	300	408.0	420	571.2
7/8-9	140	190.4	400	544.0	600	816.0
7/8-14	155	210.8	440	598.4	660	897.6
1-8	220	299.2	580	788.8	900	1,244.0
1-12	240	326.4	640	870.4	1,000	1,360.0

The guides and ruler furnished below are designed to help you select the appropriate hardware.

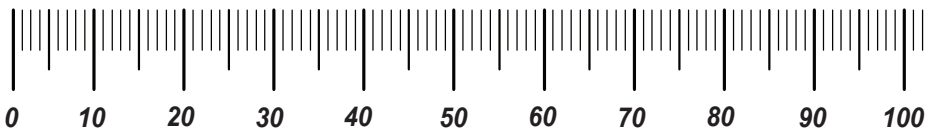

Nut, M8

Thread Diameter (mm)

Inside Diameter (in) Threads per inch

Nut, 1/2-16

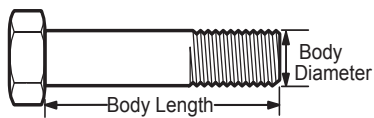

Screw, M8- 1.25 x 25

Thread Diameter (mm) Distance between threads (mm) Body Length (mm)

Body Diameter Threads per inch Body Length (in)

Screw, 1/2- 16 x 2

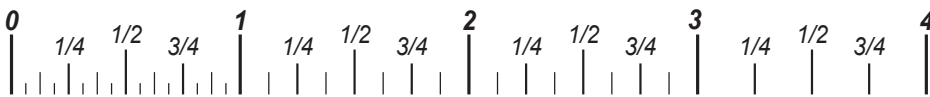

Standard Hardware Sizing

When a washer or nut is identified as 1/2" (M8), this is the *Nominal size*, meaning the *inside diameter* is 1/2 inch (8mm metric thread diameter); if a second number is present it represents the *threads per inch* (distance between threads).

When bolt or capscrew is identified as 1/2 - 16 x 2" (M8 - 1.25 x 50), this means the *Nominal size*, or body diameter is 1/2 inch (8mm metric thread diameter), the second number, 16, represents the *threads per inch*, (*distance between threads*). The final number is the body length of the bolt or screw, 2 inches (50mm).

NOTES

- These torque values are to be used for all hardware excluding: locknuts, self-tapping screws, thread forming screws, sheet metal screws and socket head setscrews.
- Recommended seating torque values for locknuts:
 - for prevailing torque locknuts - use 65% of grade 5 torques.
 - for flange whizlock nuts and screws - use 135% of grade 5 torques.
- Unless otherwise noted on assembly drawings, all torque values must meet this specification.

Common Hardware Types

Hex Head Capscrew



Washer



Carriage Bolt



Hex Nut

Wrench & Fastener Size Guide

1/4" Bolt or Nut Wrench—7/16"	5/16" Bolt or Nut Wrench—1/2"	3/8" Bolt or Nut Wrench—9/16"	7/16" Bolt or Nut Wrench (Bolt)—5/8" Wrench (Nut)—11/16"	1/2" Bolt or Nut Wrench—3/4"
M6 Bolt or Nut Wrench—10mm	M8 Bolt or Nut Wrench—13mm	M10 Bolt or Nut Wrench—17mm	M12 Bolt or Nut Wrench—19mm	M14 Bolt or Nut Wrench—22mm

