

Robex

# 180w-9A

With Tier 4 Interim Engine installed

MOVING YOU FURTHER

HYUNDAI HEAVY INDUSTRIES



\*Photo may include optional equipment

 **HYUNDAI**  
CONSTRUCTION EQUIPMENT AMERICAS, INC.

# PRIDE AT WORK

Hyundai Heavy Industries strives to build state-of-the-art earthmoving equipment to give every operator maximum performance, more precision, versatile machine preferences, and proven quality.

***Take pride in your work with Hyundai!***



# Robex 180w-9A

## Machine Walk-Around

### Engine Technology

Proven, reliable, fuel efficient, low emission and low noise  
Cummins Tier 4 interim & EU stage III B engine

### Hydraulic System Improvements

New patented hydraulic control for improved controllability / Improved control valve design for added efficiency and smoother operation / New auto boom and swing priority system for optimum speed / New auto power boost feature for additional power when needed / Improved arm-in and boom-down flow regeneration system for added speed and efficiency

### Pump Compartment

Industry-leading, powerful, reliable Kawasaki designed, variable volume in-line axial piston pumps  
New compact solenoid block equipped with 3 solenoid valves, 1 EPPR valve, 1 check valve accumulator and pilot filter - controls 2 speed travel, power boost, boom priority, safety lock

### Enhanced Operator Cab

#### Improved Visibility

Enlarged cab with improved visibility / See-through upper skylight for visibility and ventilation  
Larger right-side glass, now one piece, for better right visibility  
Safety glass windows on all sides - less expensive than (polycarbonate) and won't scratch or fade  
Closeable sunshade for operator convenience / Reduced front window seam for improved operator view

#### Improved Cab Construction

New steel tube construction for added operator safety, protection and durability  
New window open/close mechanism designed with cable and spring lift assist and single latch release

#### Improved Suspension Seat / Console Assembly

Ergonomic joysticks with auxiliary control buttons for attachment use. Now with new sleek styling  
Heated suspension (standard) or optional air ride suspension with heat  
New joystick consoles - now adjustable in height by pushing the button  
Integrated seat with consoles - reduce the operator fatigue

#### Advanced 7" Color Cluster with Touch Screen

New Color LCD Display with easy to read digital gauges for hydraulic oil temperature, water temperature, and fuel. Simplified design makes adjustment and diagnostics easier. Also, new enhanced features such as rear-view camera are integrated into monitor.

3 power modes : (P) Power, (S) Standard, (E) Economy, 2 work modes : Dig & Attachment, (U) User mode for operator preference

Enhanced self-diagnostic features with GPS download capability

One pump flow or two pump flow for optional attachment is now selectable through the cluster / New anti-theft system with password capability

Boom speed and arm regeneration are selectable through the monitor.

Auto power boost is now available - selectable (on/off) through the monitor.

Powerful air conditioning and heat with auto climate control

RMS (Remote Management System) works through GPS/satellite technology to ultimately provide better customer service and support.

### Improved Steering Column

Slim-profile steering column capable of telescoping 60 mm and tilting 30 degrees



\*Photo may include optional equipment.

# PRECISION

Innovative hydraulic system technologies make the 9A series excavator fast, smooth and easy to control.



\*Photo may include optional equipment.

## Computer Aided Power

The engine horsepower and hydraulic horsepower together in unison through the advanced CAPO(Computer Aided Power Optimization) system, flow for the job at hand. Operator can set their own preferences for boom or swing priority, power mode selection and optional work tools at the touch of a button.

The CAPO system also provides complete self diagnostic features and digital gauges for important information like hydraulic oil temperature, water temperatures and fuel level. This system interfaces with multiple sensors placed throughout the hydraulic system as well as the electronically controlled engine to provide the optimum level of engine power and hydraulic flow.

### Power Mode

P (Power Max) mode maximizes machine speed and power for mass production. S (Standard) mode provides a reduced, fixed rpm for optimum performance and improved fuel economy. For maximum fuel savings and improved control, E (Economy) mode provides precise flow and engine power based on load demand. Three unique power modes provide the operator with custom power, speed and fuel economy.

### Work Mode

The work mode allows the operator to select single flow attachments like a hydraulic breaker or bi-directional flow attachments like a crusher. Flow settings unique to each attachment can be programmed from within the cluster.

### User Mode

Some jobs require more precise machine settings. Using the versatile U (User) mode, the operator can customize engine speed, pump output, idle speed and other machine settings for the job at hand.

## Improved Hydraulic System

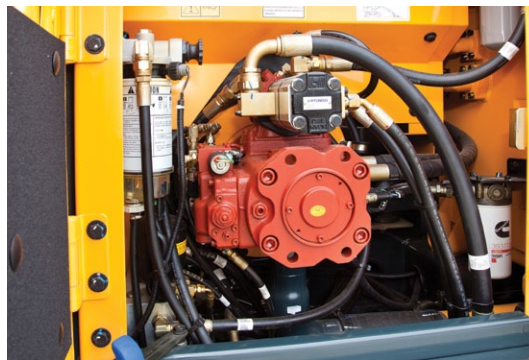

To achieve optimum precision, Hyundai redesigned the hydraulic system to provide the operator with super fine touch and improved controllability. Improved pump flow control reduces flow when controls are not being used to minimize fuel consumption.

Improved spool valves in the control valve are engineered to provide more precise flow to each function with less effort.

Improved hydraulic valves, precision-designed variable volume piston pumps, fine-touch pilot controls, and enhanced travel functions make any operator running a 9A series look like a smooth operator. Newly improved

features include arm-in and boom-down flow regeneration, improved control valve technology and innovative auto boom and swing priority for optimal performance in any application.



### Auto Boom-swing Priority

This smart function automatically and continuously looks the ideal hydraulic flow balance for the boom and swing motions of the machine. The advanced CAPO system monitors the hydraulic system and adjusts its settings to maximize performance and productivity.

# PERFORMANCE

9A series is designed for maximum performance to keep the operator working productively.



\*Photo may include optional equipment.



## Fully Independent Outrigger System

R180W-9A can be equipped with four independent outriggers (front and rear) or two independent outriggers and a dozer blade (front or rear). Each outrigger and the dozer blade are controlled by a switch and the dozer lever. Each outrigger is equipped with cylinder guards for added protection.

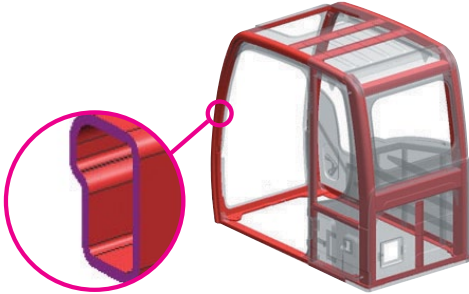

## Structure Strength

The 9A series cabin structure has been fitted with stronger but slimmer tubing for more safety and improved visibility. Low-stress, high strength steel is integrally welded to form a stronger, more durable upper and lower frame. Structural integrity was tested by way of FEM (Finite Elements Method) analysis and long-term durability tests. The optional ROPS (Roll Over Protective Structure) cab can be equipped to enhance operator safety.

## New and Improved Travel System

Auto cruise control system reduces operator fatigue by maintaining a fixed speed when driving distances. A new auto ram lock system is available to improve operating safety.

A new creep speed travel system improves maneuverability and fine control.

A new optional forward / reverse travel pedal control allows operators to choose to use the travel pedal control while in work mode or lever control when in travel mode.

## CUMMINS QSB 6.7 Engine

The Tier IV Interim, six cylinder, 4 cycle, turbo-charged, charge air cooled, Cummins QSB 6.7 engine provides maximum power, reliability, optimum fuel economy, and reduced emissions. Electronically controlled fuel injection and diagnostic capabilities add to the engines efficiency and serviceability.



# PREFERENCE

Operating a 9A series is unique to every operator. Operators can fully customize their work environment and operating preferences to fit their individual needs.



\*Photo may include optional equipment.



## Wide Cabin with Excellent Visibility

The newly designed cabin was conceived for more space, a wider field of view and operator comfort. Special attention was given to a clear, open and convenient interior with plenty of visibility on the machine surroundings and the job at hand. This well balanced combination of precision aspects put the operator in the perfect position to work safely and securely.



## Operator Comfort

In 9A series cabin you can easily adjust the seat, console and armrest settings to best suit your comfort level. The seat integrated with console absorb console vibration by seat suspension and reduce operator's fatigue. New joystick consoles are adjustable in height by pushing the button. Other preference settings that add to overall operator comfort include the fully automatic high capacity airconditioning system, transparent polycarbonate glass sun roof, large and easy to control sun visor, and the Radio / USB player.



## Reduced Stress

Work is stressful enough. Your work environment should be stress free. Hyundai's 9A series provides improved cab amenities, additional space and a comfortable seat to minimize stress to the operator. A powerful climate control system provides the operator with optimum air temperature. An advanced audio system with USB player, AM/FM stereo and MP3 capabilities, plus remotely located controls is perfect for listening to music favorites. Operators can even talk on the phone with the hands-free cell phone feature. Also, the newly designed optional remote control offers mobile bluetooth-handsfree and radio cable-handsfree function.



## Smart Key System (Option)

User authentication and anti-theft system are reinforced with smart key system. This allows the operator to start the engine with the push of a starter button rather than inserting a key into the ignition.



## Operator - Friendly Cluster

The advanced new cluster with 7 inch wide color LCD with touch screen and toggle switch allows the operator to select his personal machine preferences. Power and work mode selection, self diagnostics, optional rear-view camera, maintenance check lists, start-up machine security, and video functions were integrated into the cluster to make the machine more versatile and the operator more productive.

The newly applied FM transmitter application transmits signal to USB & Radio player with the same frequency as cluster. The player outputs the audio through the internal speaker in the cab. The video & firmware updates are possible with USB host support and an adjustable cluster hinge bracket improves cluster visibility.

## Monitor Tilt Range



# PROFITABILITY

9A series is designed to maximize profitability through improved efficiencies, enhanced service features and longer life components.



\*Photo may include optional equipment.

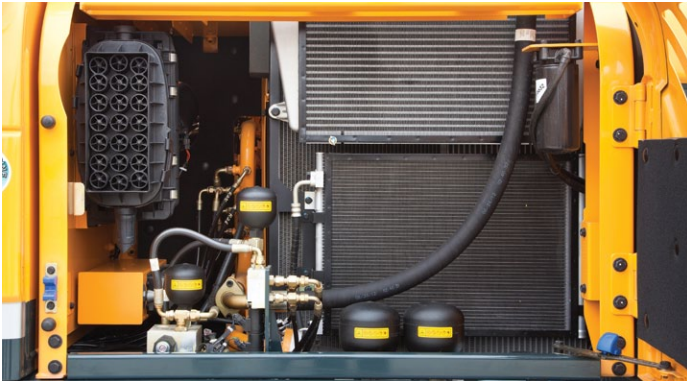

## Fuel Efficiency

9A series excavators are engineered to be extremely fuel efficient. New innovations like the fan clutch, two-stage auto decel system and the new economy mode help to conserve fuel and reduce the impact on the environment.

## Hi-mate (Remote Management System)

Hi-mate, Hyundai's proprietary remote management system, provides operators and dealer service personnel access to vital service and diagnostic information on the machine from any computer with internet access. Users can pinpoint machine location using digital mapping and set machine work boundaries, reducing the need for multiple service calls. Hi-mate saves time and money for the owner and dealer by promoting preventative maintenance and reducing machine downtime.



## Easy Access

Ground-line access to filters, lube fittings, fuses, machine computer components and wide open compartments makes service more convenient on the 9A series.



## Long-Life Components

9A series excavators were designed with bushings designed for long-life lube intervals (250 hrs) & polymer shims (wear resistant, noise reducing), long-life hydraulic filters (1,000hrs), long-life hydraulic oil (5,000hrs), more efficient cooling systems and integrated preheating systems which extend service intervals, minimize operating costs and reduce machine down time.

# Specifications

## ENGINE

MODEL		Cummins QSB 6.7	
Type		Water-cooled, 4-cycle diesel, 6-cylinder in-line, Direct injection, Turbocharged, Charge air cooled, Low emission	
Rated flywheel horsepower	SAE	J1995 (gross)	165 HP (123kW) at 2,200 rpm
		J1349 (net)	155 HP (115kW) at 2,200 rpm
	DIN	6271/1 (gross)	167 PS (123kW) at 2,200 rpm
		6271/1 (net)	157 PS (115kW) at 2,200 rpm
Max. torque		74.7 kgf·m(540 lbf·ft) at 1,500 rpm	
Bore X stroke		107 x 124 mm (4.21" x 4.88")	
Piston displacement		6,700 cc (409 in <sup>3</sup> )	
Batteries		2 x 12 V x 100 AH	
Starting motor		24V-4.8kW	
Alternator		24V-95 Amp	

## HYDRAULIC SYSTEM

MAIN PUMP	
Type	Two variable displacement piston pumps
Rated flow	2 X 172 L /min (45.4 US gpm/37.8 UK gpm)
Sub-pump for pilot circuit	Gear pump

Cross-sensing and fuel saving pump system

## HYDRAULIC MOTORS

Travel	Variable displacement pistons motor with brake valve
Swing	Axial piston motor with automatic brake

## RELIEF VALVE SETTING

Implement circuits	350 kgf/cm <sup>2</sup> (4,970 psi)
Travel	380 kgf/cm <sup>2</sup> (5,400 psi)
Power boost (boom, arm, bucket)	380 kgf/cm <sup>2</sup> (5,400 psi)
Swing circuit	285 kgf/cm <sup>2</sup> (4,050 psi)
Pilot circuit	40 kgf/cm <sup>2</sup> (570 psi)
Service valve	Installed

## HYDRAULIC CYLINDERS

No. of cylinder bore X stroke	Boom : 2-115 x 1090 mm (4.5" x 42.9")
	Arm : 1-120 x 1355 mm (4.7" x 53.3")
	Bucket : 1-110 x 995 mm (4.3" x 39.2")
	Blade : 2-110 x 235 mm (4.3" x 9.3")
	Outrigger : 2-125 x 463 mm (4.9" x 18.2")
	2-PCS boom : 2-115 x 960 mm (4.1" x 37.8")
	Adjust(boom) : 1-160 x 650 mm (6.3" x 25.6")

## DRIVES & BRAKES

4-wheel hydrostatic drive. Constant mesh, helical gear transmission provides 2 forward and reverse travel speeds.

Max. drawbar pull	11,000 kgf (24,250 lbf)	
Travel speed	1st	9.5 km/h
	2nd	35 km/h
Gradeability	35' (70 %)	

Parking brake : Independent dual brake, front and rear axle full hydraulic power brake.

- Spring released and hydraulic applied wet type multiple disk brake.
- Transmission is locked at neutral position for parking, automatically.

## CONTROL

Pilot pressure operated joysticks and pedals with detachable lever provide almost effortless and fatigueless operation.

Pilot control	Two joysticks with one safety lever (LH): Swing and arm, (RH): Boom and bucket (ISO)
Engine throttle	Electric, Dial type

## AXLE & WHEEL

Full floating front axle is supported by center pin for oscillation. It can be locked by oscillation lock cylinders. Rear axle is fixed on the lower chassis.

Tires	10.00-20-14PR, Dual(tube type)
(optional)	10.00-20, Dual(solid type)

## SWING SYSTEM

Swing motor	Fixed displacement axial pistons motor
Swing reduction	Planetary gear reduction
Swing bearing lubrication	Grease-bathed
Swing brake(option)	Multi wet disc(pin lock type)
Swing speed	9.1 rpm

## STEERING SYSTEM

Hydraulically actuated, orbitrol type steering system actuates on front wheels through the steering cylinders.

Min. turning radius	6,300 mm(20' 8")
---------------------	------------------

## COOLANT & LUBRICANT CAPACITY

	liter	US gal	UK gal
Re-filling			
Fuel tank	270	71.3	59.4
Engine coolant	19.5	5.2	4.3
Engine oil	23.7	6.3	5.2
Swing device - gear oil	5	1.3	1.1
Axle	Front	15.5	4.1
	Rear	17.5	4.6
Hydraulic system (including tank)	270	71.3	59.4
Hydraulic tank	160	42.3	35.2

## UNDERCARRIAGE

Reinforced box-section frame is all-welded, low-stress.

Dozer blade and outriggers are available. A pin-on design.

Dozer blade	A very useful addition for leveling and back filling or clean-up work.
Outrigger	Indicated for max. operation stability when digging and lifting. Can be mounted on the front/or the rear.

## OPERATING WEIGHT (APPROXIMATE)

Operating weight, including 5,200mm (17' 1") Mono boom, 2,600mm (8' 6") arm, SAE heaped 0.76m<sup>3</sup> (0.99yd<sup>3</sup>) backhoe bucket, lubricant, coolant, full fuel tank, hydraulic tank and the standard equipment.

## MAJOR COMPONENT WEIGHT

Upperstructure	4,590kg (10,120 lb)
Mono boom(with arm cylinder)	1,275kg (2,810 lb)
Hydraulic adjustable boom (with adjust cylinder and arm cylinder)	1,780kg (3,920 lb)

## OPERATING WEIGHT

	Mono boom	Hyd. adjustable boom
Undercarriage		
Rear dozer blade	17,280 (38,100)	17,750 (39,130)
Rear outrigger	17,430 (38,430)	17,900 (39,460)
Front outrigger and rear blade	18,400 (40,560)	18,870 (41,600)
Front blade and rear outrigger	18,340 (40,430)	18,810 (41,470)
Four outrigger	18,580 (40,960)	19,050 (42,000)

## BUCKETS

All buckets are welded with high-strength steel.



0.39 (0.51)

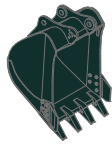

0.50 (0.65)



0.64 (0.84)



0.76 (0.99)



0.89 (1.16)

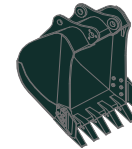

1.05 (1.37)

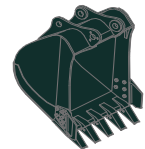

⊙0.69 (0.90)

SAE heaped m<sup>3</sup> (yd<sup>3</sup>)

Capacity m <sup>3</sup> (yd <sup>3</sup> )		Width mm (in)		Weight kg (lb)	Recommendation m (ft-in)				
SAE heaped	CECE heaped	Without sidecutters	With sidecutters		5,200 (17' 1") Mono Boom			5,100 (16' 1") Hydraulic Adjustable Boom	
					2,200 (7' 3") Arm	2,600 (8' 6") Arm	3,100 (10' 2") Arm	2,200 (7' 3") Arm	2,600 (8' 6") Arm
0.39 (0.51)	0.34(0.44)	620(24.4)	740(29.1)	410(900)	●	●	●	●	●
0.50 (0.65)	0.44(0.58)	760(29.9)	880(34.6)	470(1040)	●	●	●	●	●
0.64 (0.84)	0.55(0.72)	920(36.2)	1,040(40.9)	510(1120)	□	□	▲	□	□
0.76 (0.99)	0.65(0.85)	1,060(41.7)	1,180(46.5)	570(1260)	□	▲	▲	□	▲
0.89 (1.16)	0.77(1.01)	1,220(48.0)	1,340(52.8)	610(1340)	▲	▲	-	▲	▲
1.05 (1.37)	0.90(1.18)	1,400(55.1)	1,520(59.8)	680(1500)	▲	-	-	▲	-
⊙0.69 (0.90)	0.62(0.81)	990(39.0)	-	700(1540)	□	▲	▲	□	▲

⊙ Heavy duty bucket

Note Dozer Blade down

●: Applicable for materials with density of 2,000 kg /m<sup>3</sup> (3,370 lb/ yd<sup>3</sup>) or less

□: Applicable for materials with density of 1,600 kg /m<sup>3</sup> (2,700 lb/ yd<sup>3</sup>) or less

▲: Applicable for materials with density of 1,100 kg /m<sup>3</sup> (1,850 lb/ yd<sup>3</sup>) or less

## ATTACHMENT

Booms and arms are welded with a low-stress, full-box section design. 5.2m (17' 1") boom, 5.1m (16' 1") Hydraulic Adjustable Boom and 2.2m (7' 3"), 2.6m (8' 6"), 3.1m (10' 2") arms.

## DIGGING FORCE

Boom	Length	mm (ft-in)	5,200 (17' 1")			Remarks
	Weight	kg (lb)	1,240 (2,730)			
Arm	Length	mm (ft-in)	2,200 (7' 3")	2,600 (8' 6")	3,100 (10' 2")	[ ]: Power Boost
	Weight	kg (lb)	750 (1,560)	810 (1,790)	890 (1,960)	
Bucket digging force	SAE	kN	107.9 [117.2]	107.9 [117.2]	107.9 [117.2]	
		kgf	11,000 [11,940]	11,000 [11,940]	11,000 [11,940]	
		lbf	24,250 [26,330]	24,250 [26,330]	24,250 [26,330]	
	ISO	kN	123.6 [134.2]	123.6 [134.2]	123.6 [134.2]	
		kgf	12,600 [13,680]	12,600 [13,680]	12,600 [13,680]	
		lbf	27,780 [30,160]	27,780 [30,160]	27,780 [30,160]	
Arm crowd force	SAE	kN	87.2 [94.7]	77.3 [83.9]	69.0 [74.9]	
		kgf	8,890 [9,650]	7,880 [8,560]	7,030 [7,630]	
		lbf	19,600 [21,280]	17,270 [18,860]	15,500 [16,830]	
	ISO	kN	91.0 [98.8]	80.3 [87.2]	71.4 [77.5]	
		kgf	9,280 [10,080]	8,190 [8,890]	7,280 [7,900]	
		lbf	20,460 [22,210]	18,060 [19,600]	16,050 [17,430]	

Note: Boom weight includes arm cylinder, piping, and pin

Arm weight includes bucket cylinder, linkage, and pin

# Dimensions & Working Range

## R180W-9A DIMENSIONS

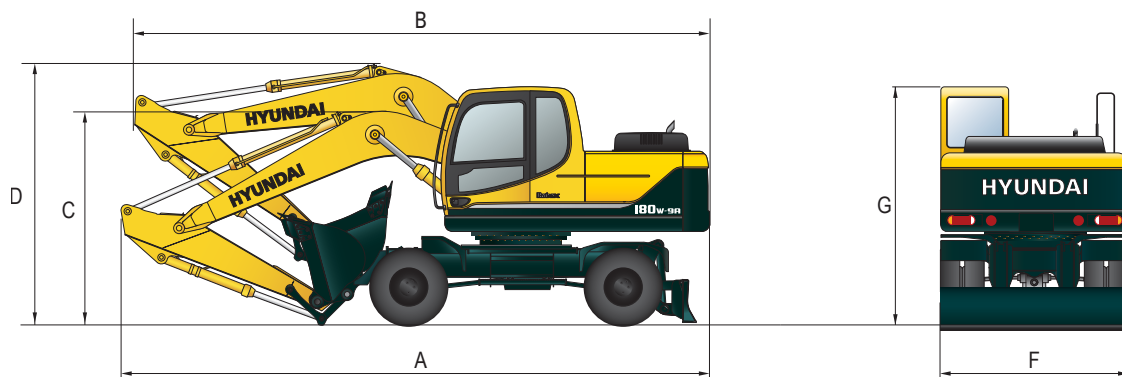

Unit : mm (ft · in)

Mono Boom	5,200(17' 1")		
Arm	2,200 (7' 3")	2,600 (8' 6")	3,100 (11' 1")
A Overall length of shipping position	8,650 (28' 5")	8,760 (28' 9")	8,760 (28' 9")
B Overall length of traveling position	8,590 (28' 2")	8,710 (28' 7")	8,480 (27' 10")
C Height of attachment(shipping position)	3,060 (10' 0")	3,180 (10' 6")	3,150 (10' 4")
D Height of attachment(traveling position)	3,610 (11' 10")	3,540 (11' 8")	3,900 (12' 10")
F Overall width	2,500 (8' 2")	2,500 (8' 2")	2,500 (8' 2")
G Height of cabin	3,190 (10' 6")	3,190 (10' 6")	3,190 (10' 6")

## R180W-9A WORKING RANGE

Unit : mm (ft · in)

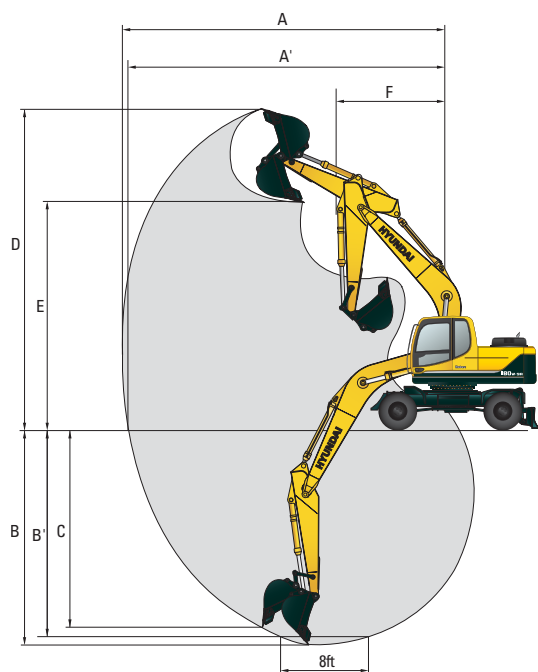

Boom length	5,200 (17' 1")		
Arm length	2,200 (7' 3")	2,600 (8' 6")	3,100 (10' 2")
A Max. digging reach	8,820 (29' 1")	9,200 (30' 3")	9,450 (31' 0")
A' Max. digging reach on ground	8,615 (28' 4")	9,000 (29' 7")	9,250 (30' 4")
B Max. digging depth	5,500 (18' 2")	5,900 (19' 5")	6,320 (20' 9")
B' Max. digging depth (8' level)	5,280 (17' 5")	5,700 (18' 9")	6,130 (20' 1")
C Max. vertical wall digging depth	4,850 (16' 1")	5,310 (17' 6")	5,470 (17' 11")
D Max. digging height	9,180 (30' 3")	9,300 (30' 7")	9,220 (30' 3")
E Max. dumping height	6,520 (21' 5")	6,660 (21' 8")	6,620 (21' 9")
F Min. swing radius	3,290 (10' 9")	3,230 (10' 8")	3,160 (10' 4")

# Dimensions & Working Range

## R180W-9A ADJUSTABLE BOOM

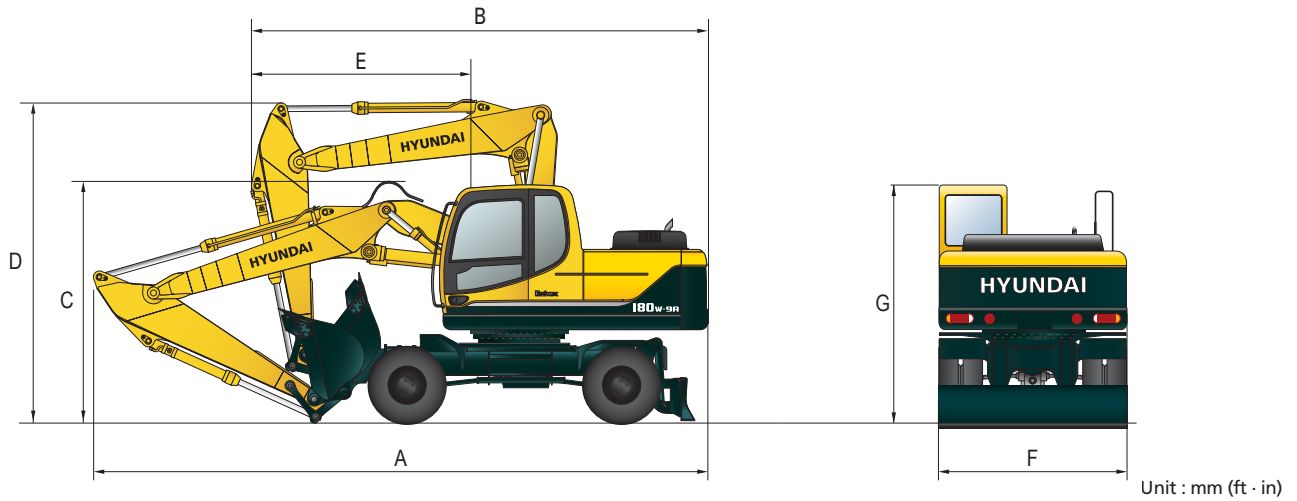

Unit : mm (ft · in)

Hydraulic adjustable Boom	5,200(17' 1")	
Arm	2,200 (7' 3")	2,600 (8' 6")
A Overall length of shipping position	8,650 (28' 5")	8,750 (28' 8")
B Overall length of traveling position	6,630 (21' 9")	6,620 (21' 9")
C Height of attachment(shipping position)	2,900 (9' 6")	2,920 (9' 7")
D Height of attachment(traveling position)	3,980 (13' 1")	3,960 (13' 0")
E End of attachment to steering wheel	3,300 (10' 10")	3,290 (10' 10")
F Overall width	2,500 (8' 2")	2,500 (8' 2")
G Height of cabin	3,190 (10' 6")	3,190 (10' 6")

## R180W-9A ADJUSTABLE BOOM WORKING RANGE

Unit : mm (ft · in)

Boom length	5,200 (17' 1")	
Arm length	2,200 (7' 3")	2,600 (8' 6")
A Max. digging reach	8,760 (28' 9")	9,110 (29' 11")
A' Max. digging reach on ground	8,550 (28' 1")	8,910 (29' 3")
B Max. digging depth	5,220 (17' 2")	5,620 (18' 5")
B' Max. digging depth (8' level)	5,120 (16' 10")	5,520 (18' 1")
C Max. vertical wall digging depth	4,430 (14' 6")	4,780 (15' 8")
D Max. digging height	9,630 (31' 7")	9,820 (32' 3")
E Max. dumping height	6,930 (22' 9")	7,130 (23' 5")
F Min. swing radius	3,100 (10' 2")	2,970 (9' 9")

# Undercarriage

**R180W-9A WITH REAR DOZER AND FRONT REST**

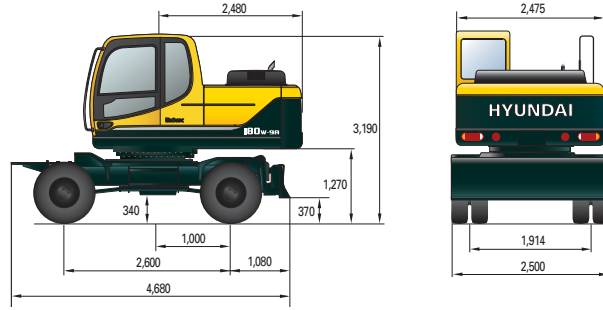

**R180W-9A WITH REAR OUTRIGGER AND FRONT REST**

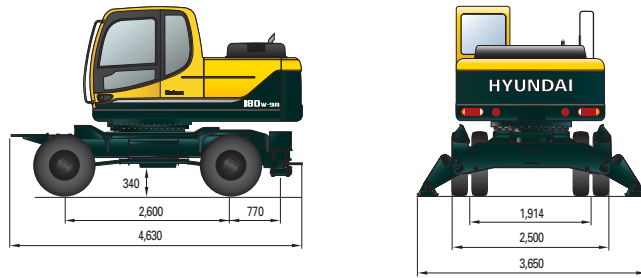

**R180W-9A WITH REAR DOZER AND FRONT OUTRIGGER**

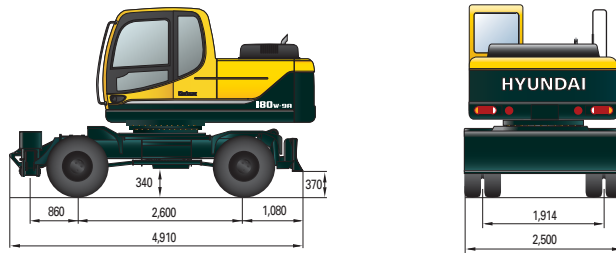

**R180W-9A WITH REAR AND FRONT OUTRIGGER**

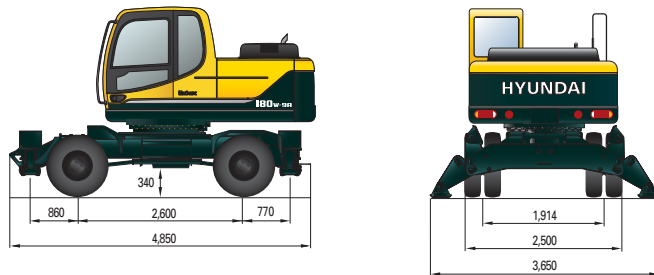

**R180W-9A WITH REAR OUTRIGGER AND FRONT DOZER**

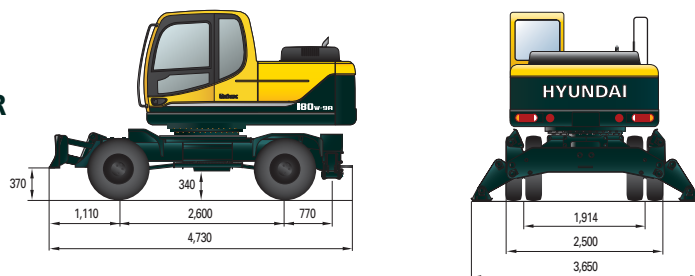















# Lifting Capacity













## R180W-9A MONO BOOM

 Rating over-front  Rating over-side or 360 degree













Boom : 5.2 m (17' 1") / Arm : 2.2 m (7' 3") / Bucket : 0.76 m<sup>3</sup> (0.99 yd<sup>3</sup>) / Dozer blade down with 3,150kg CWT

Load point height m (ft)	Load radius										At max. reach			
	1.5 m (5 ft)		3.0 m (10 ft)		4.5 m (15 ft)		6.0 m (20 ft)		7.5 m (25 ft)		Capacity		Reach	
													m (ft)	
7.5 m (25 ft)	kg											*3680	3080	6.09
	lb											*8110	6790	(20.0)
6.0 m (20 ft)	kg							*3630	3080			*3610	2180	7.30
	lb							*8000	6790			*7960	4810	(24.0)
4.5 m (15 ft)	kg					*4750	*4750	*4130	3010			*3630	1790	8.00
	lb					*10470	*10470	*9110	6640			*8000	3950	(26.2)
3.0 m (10 ft)	kg					*6020	4520	*4660	2860	*2670	1920	3560	1610	8.32
	lb					*13270	9960	*10270	6310	*5890	4230	7850	3550	(27.3)
1.5 m (5 ft)	kg					*7180	4170	*5210	2700	*3480	1860	3520	1570	8.33
	lb					*15830	9190	*11490	5950	*7670	4100	7760	3460	(27.3)
Ground	kg			*7120	*7120	*7680	3990	*5510	2590			3720	1660	8.01
Line	lb			*15700	*15700	*16930	8800	*12150	5710			8200	3660	(26.3)
-1.5 m (-5 ft)	kg	*7410	*7410	*10980	7610	*7470	3950	*5370	2560			*3810	1940	7.34
	lb	*16340	*16340	*24210	16780	*16470	8710	*11840	5640			*8400	4280	(24.1)
-3.0 m (-10 ft)	kg	*11630	*11630	*9190	7790	*6420	4030					*3510	2650	6.15
	lb	*25640	*25640	*20260	17170	*14150	8880					*7740	5840	(20.2)

Boom : 5.2 m (17' 1") / Arm : 2.6 m (8' 6") / Bucket : 0.76 m<sup>3</sup> (0.99 yd<sup>3</sup>) / Dozer blade down with 3,150kg CWT

Load point height m (ft)	Load radius										At max. reach			
	1.5 m (5 ft)		3.0 m (10 ft)		4.5 m (15 ft)		6.0 m (20 ft)		7.5 m (25 ft)		Capacity		Reach	
													m (ft)	
7.5 m (25 ft)	kg											*3340	2710	6.57
	lb											*7360	5970	(21.6)
6.0 m (20 ft)	kg							*3380	3130			*3320	1970	7.70
	lb							*7450	6900			*7320	4340	(25.3)
4.5 m (15 ft)	kg							*3800	3030	*1830	*1830	*3360	1640	8.35
	lb							*8380	6680	*4030	*4030	*7410	3620	(27.4)
3.0 m (10 ft)	kg			*8730	8720	*5560	4570	*4380	2860	*3290	1920	3320	1470	8.66
	lb			*19250	19220	*12260	10080	*9660	6310	*7250	4230	7320	3240	(28.4)
1.5 m (5 ft)	kg			*6780	*6780	*6840	4180	*4990	2680	*4070	1840	3270	1430	8.67
	lb			*14950	*14950	*15080	9220	*11000	5910	*8970	4060	7210	3150	(28.4)
Ground	kg			*7720	7470	*7540	3950	*5400	2550	*3830	1780	3430	1500	8.37
Line	lb			*17020	16470	*16620	8710	*11900	5620	*8440	3920	7560	3310	(27.5)
-1.5 m (-5 ft)	kg	*7000	*7000	*10750	7480	*7530	3880	*5400	2500			*3670	1730	7.73
	lb	*15430	*15430	*23700	16490	*16600	8550	*11900	5510			*8090	3810	(25.4)
-3.0 m (-10 ft)	kg	*10290	*10290	*9880	7620	*6750	3920	*4710	2540			*3540	2280	6.63
	lb	*22690	*22690	*21780	16800	*14880	8640	*10380	5600			*7800	5030	(21.8)
-4.5 m (-15 ft)	kg			*6890	*6890	*4530	4130							
	lb			*15190	*15190	*9990	9110							

Boom : 5.2 m (17' 1") / Arm : 3.1 m (10' 2") / Bucket : 0.76 m<sup>3</sup> (0.99 yd<sup>3</sup>) / Dozer blade down with 3,150kg CWT

Load point height m (ft)	Load radius										At max. reach			
	1.5 m (5 ft)		3.0 m (10 ft)		4.5 m (15 ft)		6.0 m (20 ft)		7.5 m (25 ft)		Capacity		Reach	
													m (ft)	
7.5 m (25 ft)	kg							*1940	*1940			*2980	2320	7.16
	lb							*4280	*4280			*6570	5110	(23.5)
6.0 m (20 ft)	kg							*3030	*3030			*3000	1740	8.20
	lb							*6680	*6680			*6610	3840	(26.9)
4.5 m (15 ft)	kg							*3400	3060	*2490	2000	*3060	1460	8.81
	lb							*7500	6750	*5490	4410	*6750	3220	(28.9)
3.0 m (10 ft)	kg			*7340	*7340	*4970	4650	*4020	2880	*3380	1920	3030	1310	9.10
	lb			*16180	*16180	*10960	10250	*8860	6350	*7450	4230	6680	2890	(29.9)
1.5 m (5 ft)	kg			*9440	7930	*6380	4230	*4700	2680	*3860	1820	2980	1270	9.11
	lb			*20810	17480	*14070	9330	*10360	5910	*8510	4010	6570	2800	(29.9)
Ground	kg			*8250	7460	*7300	3940	*5220	2530	4020	1740	3110	1320	8.83
Line	lb			*18190	16450	*16090	8690	*11510	5580	8860	3840	6860	2910	(29.0)
-1.5 m (-5 ft)	kg	*6520	*6520	*10260	7370	*7530	3820	*5380	2440	*3370	1710	*3450	1500	8.23
	lb	*14370	*14370	*22620	16250	*16600	8420	*11860	5380	*7430	3770	*7610	3310	(27.0)
-3.0 m (-10 ft)	kg	*9180	*9180	*10560	7460	*7040	3820	*4990	2440			*3450	1920	7.21
	lb	*20240	*20240	*23280	16450	*15520	8420	*11000	5380			*7610	4230	(23.7)
-4.5 m (-15 ft)	kg	*12710	*12710	*8140	7710	*5470	3960					*3050	*3050	5.51
	lb	*28020	*28020	*17950	17000	*12060	8730					*6720	*6720	(18.1)













- Lifting capacity are based on SAE J1097, ISO 10567.
- Lifting capacity of the Robex Series does not exceed 75% of the tipping load with the machine on firm, level ground or 87% of full hydraulic capacity.
- The load point is a hook (standard equipment) located on the back of the bucket.
- (\*) indicates load limited by hydraulic capacity.

# Lifting Capacity













## R180W-9A ADJUSTABLE BOOM

 Rating over-front  Rating over-side or 360 degree

Boom : 5.1 m (16' 9") / Arm : 2.2 m (7' 3") / Bucket : 0.76 m<sup>3</sup> (0.99 yd<sup>3</sup>) / Dozer blade down with 3,150kg CWT

Load point height m (ft)	Load radius										At max. reach			
	1.5 m (5 ft)		3.0 m (10 ft)		4.5 m (15 ft)		6.0 m (20 ft)		7.5 m (25 ft)		Capacity		Reach	
													m (ft)	
6.0 m (20 ft)	kg											*3710	2210	7.22
	lb											*8180	4870	(23.7)
4.5 m (15 ft)	kg						*4210	3020				*3680	1810	7.92
	lb						*9280	6660				*8110	3990	(26.0)
3.0 m (10 ft)	kg				*6040	4550	*4690	2860				3660	1620	8.25
	lb				*13320	10030	*10340	6310				8070	3570	(27.1)
1.5 m (5 ft)	kg				*7120	4180	*5190	2700	*3430	1820		3610	1590	8.26
	lb				*15700	9220	*11440	5950	*7560	4080		7960	3510	(27.1)
Ground Line	kg			*6770	*6770	*7590	3980	*5450	2580			*3750	1680	7.94
	lb			*14930	*14930	*16730	8770	*12020	5690			*8270	3700	(26.0)
-1.5 m (-5 ft)	kg	*6880	*6880	*10730	7600	*7310	3940	*5230	2560			*3640	1980	7.26
	lb	*15170	*15170	*23660	16760	*16120	8690	*11530	5640			*8020	4370	(23.8)
-3.0 m (-10 ft)	kg			*8720	7820	*6110	4040					*3140	2750	6.05
	lb			*19220	17240	*13470	8910					*6920	6060	(19.8)

Boom : 5.1 m (16' 9") / Arm : 2.6 m (8' 6") / Bucket : 0.76 m<sup>3</sup> (0.99 yd<sup>3</sup>) / Dozer down with 3,150kg CWT

Load point height m (ft)	Load radius										At max. reach			
	1.5 m (5 ft)		3.0 m (10 ft)		4.5 m (15 ft)		6.0 m (20 ft)		7.5 m (25 ft)		Capacity		Reach	
													m (ft)	
6.0 m (20 ft)	kg											*3410	2000	7.63
	lb											*7520	4410	(25.0)
4.5 m (15 ft)	kg											*3410	1650	8.29
	lb											*7520	3640	(27.2)
3.0 m (10 ft)	kg						*4420	2870	*3380	1910		3400	1480	8.60
	lb						*9740	6330	*7450	4210		7500	3260	(28.2)
1.5 m (5 ft)	kg			*6600	*6600	*6800	4200	*4980	2680	*4050	1830	3350	1440	8.61
	lb			*14550	*14550	*14990	9260	*10980	5910	*8930	4030	7390	3170	(28.2)
Ground Line	kg			*7410	*7410	*7460	3950	*5340	2550	*3830	1780	3530	1520	8.31
	lb			*16340	*16340	*16450	8710	*11770	5620	*8440	3920	7780	3350	(27.3)
-1.5 m (-5 ft)	kg	*6550	*6550	*10600	7470	*7390	3870	*5290	2490			*3520	1760	7.66
	lb	*14440	*14440	*23370	16470	*16290	8530	*11660	5490			*7760	3880	(25.1)
-3.0 m (-10 ft)	kg	*10160	*10160	*9480	7640	*6500	3930	*4440	2550			*3240	2350	6.54
	lb	*22400	*22400	*20900	16840	*14330	8660	*9790	5620			*7140	5180	(21.5)
-4.5 m (-15 ft)	kg			*6100	*6100	*3870	*3870							
	lb			*13450	*13450	*8530	*8530							

1. Lifting capacity are based on SAE J1097, ISO 10567.

2. Lifting capacity of the Robex Series does not exceed 75% of the tipping load with the machine on firm, level ground or 87% of full hydraulic capacity.

3. The load point is a hook (standard equipment) located on the back of the bucket.

4. (\*) indicates load limited by hydraulic capacity.

## STANDARD EQUIPMENT

### ISO Standard cabin

All-weather steel cab with 360° visibility  
 Safety glass windows  
 Rise-up type windshield wiper  
 Sliding fold-in front window  
 Sliding side window(LH)  
 Lockable door  
 Hot & cool box  
 Storage compartment & Ashtray  
 Transparent cabin roof-cover  
 Radio & USB Player  
 Handsfree mobile phone system with USB  
 Sun visor  
 12 volt power outlet (24V DC to 12V DC converter)

### Booms

5.2m, 17' 1"

### Computer aided power optimization (New CAPO) system

3-power mode, 2-work mode, user mode  
 Auto deceleration & one-touch deceleration system  
 Auto warm-up system  
 Auto overheat prevention system

### Automatic climate control

Air conditioner & heater  
 Defroster

### Self-diagnostics system

### Starting Aid (air grid heater) for cold weather

### Centralized monitoring

LCD display  
 Engine speed or Trip meter/Accel.  
 Clock  
 Gauges  
 Fuel level gauge  
 Engine coolant temperature gauge  
 Hyd. oil temperature gauge  
 Warnings  
 Check engine  
 Overload  
 Communication error  
 Low battery  
 Air cleaner clogging  
 Indicators  
 Max power  
 Low speed/High speed  
 Fuel warmer  
 Auto idle

### Door and cab locks, one key

### Two outside rearview mirrors

### Adjustable air suspension seat with heater

### Pilot-operated slidable joystick

### Console box height adjust system

### Four front working lights

### Electric horn

### Batteries (2 x 12V x 100 AH)

### Battery master switch

### Removable clean-out screen for cooler

### Automatic swing brake

### Removable reservoir tank

### Fuel pre-filter with fuel warmer

### Boom holding system

### Arm holding system

### Accumulator for lowering work equipment

### Electric Tranducers

### Lower frame under cover (Normal)

### Viscous fan clutch

### Rear-blade (550mm X 2,500mm)

### Tires-dual (10.00-20-14PR)

### Travel alarm

## OPTIONAL EQUIPMENT

### Fuel filler pump (35 L/min)

### Beacon lamp

### Safety lock valve for boom cylinder with overload warning device

### Safety lock valve for arm cylinder

### Single-acting piping kit (breaker, etc.)

### Double-acting piping kit (clamshell, etc.)

### Quick coupler

### Arms

2.2m, 7' 3"

2.6m, 8' 6"

3.1m, 10' 2"

### Climate control

Air conditioner only

Heater only

### Cabin FOPS/FOG (ISO/DIS 10262 Level II)

FOPS (Falling Object Protective Structure)

FOG (Falling Object Guard)

### Cabin ROPS (ISO 12117-2)

ROPS(Roll Over Protective Structure)

### Cabin roof-steel cover

### Cabin front guard-wire net

### Cabin guard front

Wire net

Fine net

### Cabin lights

### Cabin front window rain guard

### Undercarriage

Rear outrigger

Rear dozer and front outrigger

Rear and front outrigger

Rear outrigger and front dozer

### Lower frame under cover (Additional)

### Tool kit

### Rearview camera

### Seat

Mechanical suspension seat with heater

### Tires - dual (10.00 - 20 solid)

### Fenders (Mudguards)

### Pattern change valve (2 patterns)

### Hi-mate (Remote Management System)

- \* Standard and optional equipment may vary. Contact your Hyundai dealer for more information. The machine may vary according to International standards.
- \* The photos may include attachments and optional equipment that are not available in your area.
- \* Materials and specifications are subject to change without advance notice.
- \* All imperial measurements rounded off to the nearest pound or inch.

---

PLEASE CONTACT



6100 Atlantic Blvd, Norcross, GA 30071  
TEL (678) 823-7777 FAX (678) 823-7778