



Parts Manual

Mfg. No: 5901752
Pathfinder (FS2100) Series Stand-On
Spreader Sprayer



Model Components	Page
Decals Group.....	4
Diverter Group.....	6
Electrical Group.....	8
Fuel Tank and Mount Group.....	10
Handlebar Group.....	12
Hopper Gate Assembly Group (120 LBS).....	14
Hopper Group (120 LBS).....	16
Main Frame Group.....	18
Operator Platform Group.....	20
Parking Brake Group.....	22
Power Transmission Group.....	24
Pump and Gearbox Group.....	26
Spray System Group.....	28
Spray Tank Group.....	30
Torque Specification Chart.....	32

Not For
In Reproduction

No Image Available

Not For
In Reproduction

Decals Group

REF NO	PART NO	QTY	DESCRIPTION
1	5102628	1	DECAL, PARKING BRAKE SYMBOLS
3	5105769	1	DECAL, COMBO SPRAY CONTROL
4	5105774	1	DECAL, WARNING / DANGER
5	5105775	1	DECAL, BRAKE PEDAL
6	5106500	1	DECAL, GEAR SELECTOR
7	5106503	1	DECAL, WARNING, MOVING PARTS
8	5106504	1	DECAL, WARNING, GUARD
9	5106505	1	DECAL, CAUTION, FLOODING
10	5106506	1	DECAL, WARNING, INJURY & TRANS. DAMAGE
11	5106507	1	DECAL, CAUTION, MUFFLER TEMP.
12	5106520	1	DECAL, PATHFINDER LEFT CONSOLE
13	5106521	1	DECAL, PATHFINDER RIGHT CONSOLE
14	5106522	1	DECAL, PATHFINDER GATE LEVER
15	5106542	1	DECAL, 3.00" FERRIS SHIELD LOGO

Not For In Reproduction

Diverter Group

Note: Unless noted otherwise, use the standard torque specifications

Mfg. No: 5901752

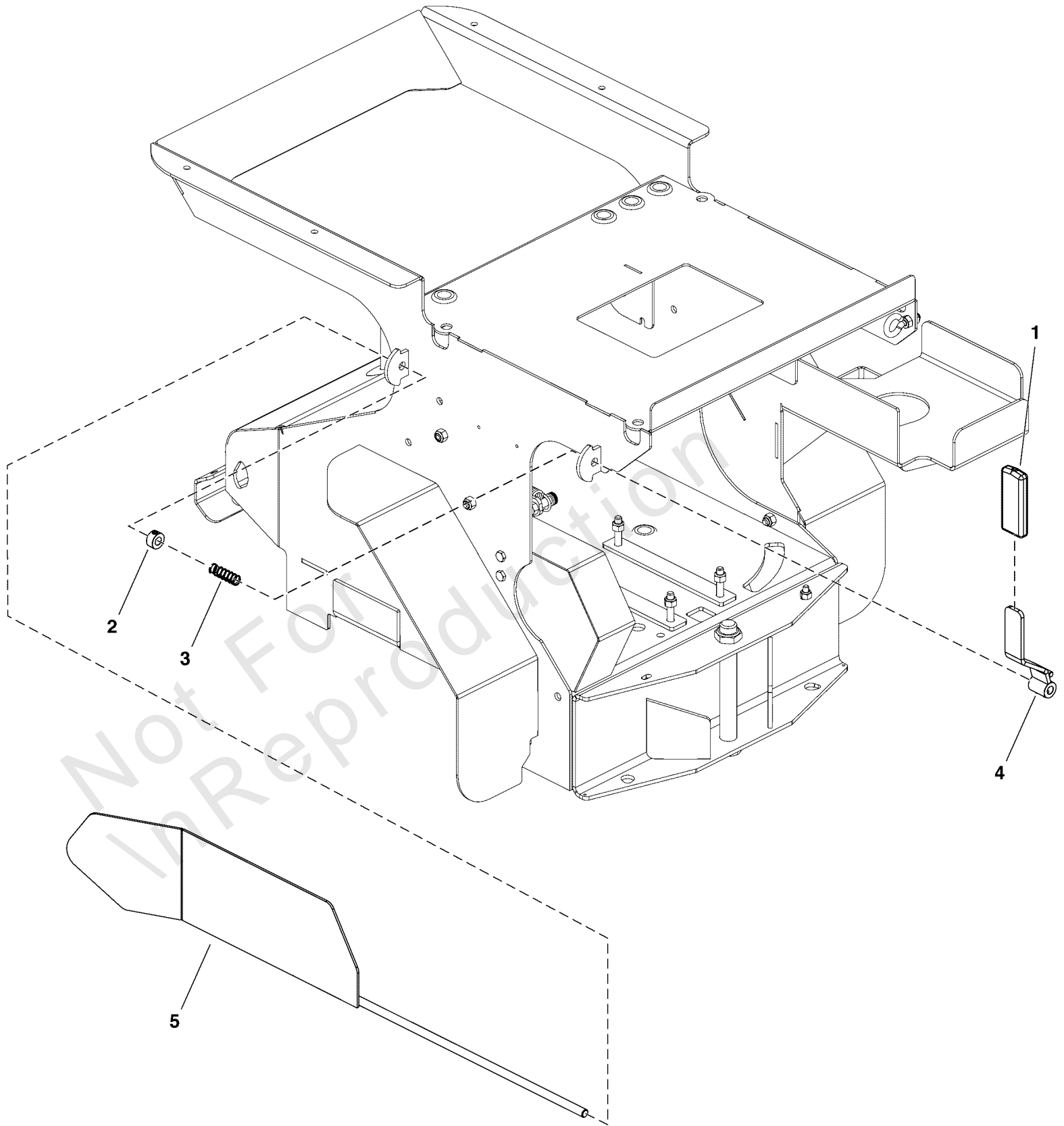

Diverter Group

REF NO	PART NO	QTY	DESCRIPTION
1	5105900	1	GRIP, .188" X 1.00" ID X .150" THK CLSD CELL FOAM
2	5106023	1	COLLAR, SHAFT .375ID X .750OD X .375WD
3	5106027	1	SPRING, COMPRESSION .480" OD X 1.500 LONG SS
4	5418073	1	WELD, HANDLE, DIVERTER
5	5418182	1	WELD, DIVERTER

Not For In Reproduction

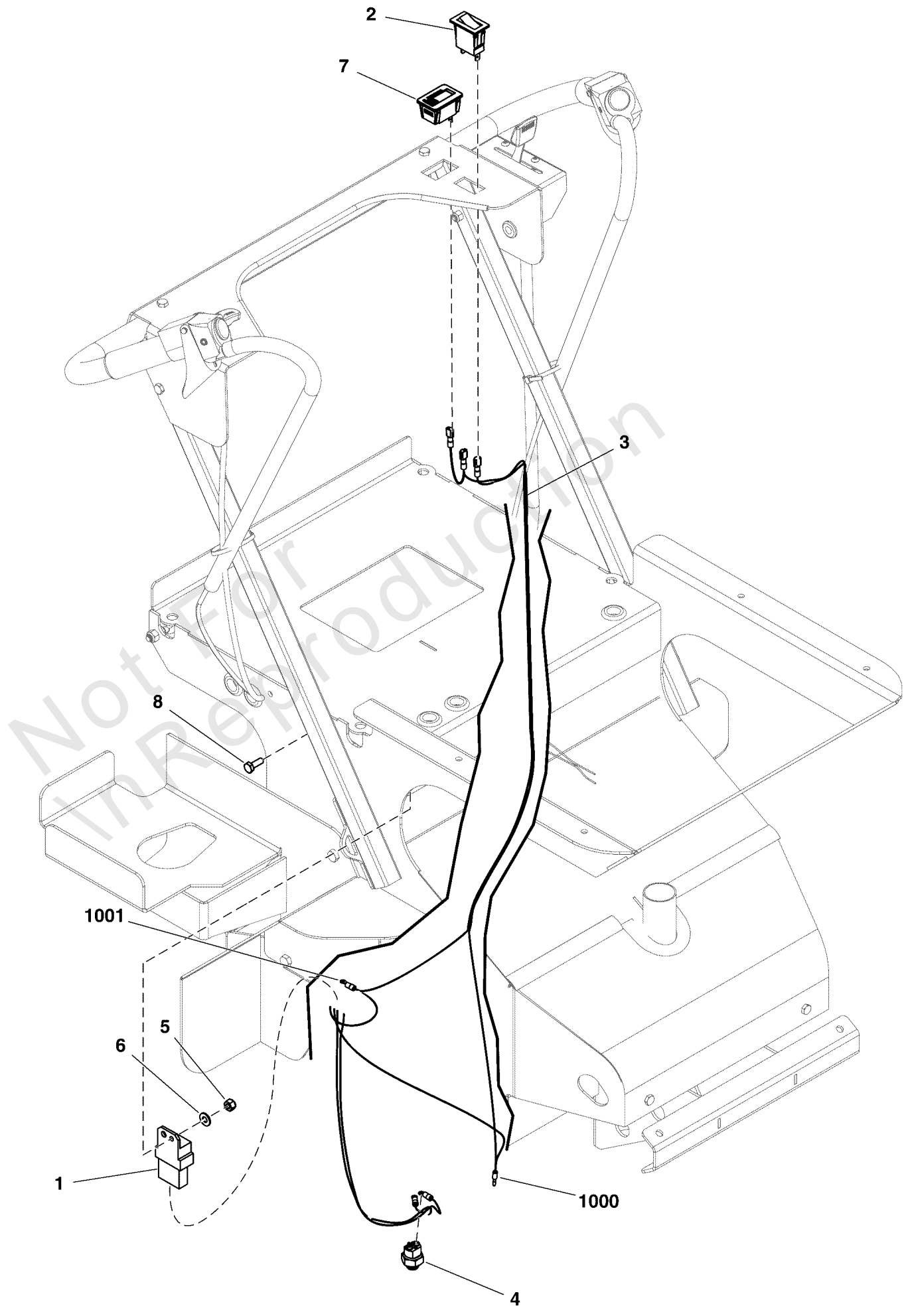

Electrical Group

REF NO	PART NO	QTY	DESCRIPTION
1	5105937	1	MODULE, SAFE-START
2	5105945	1	SWITCH, ROCKER ON/OFF
3	5106087	1	WIRE HARNESS, PATH TRANS (E0131)
4	5106017	1	PEERLESS NEUTRAL START SWITCH -(Connects to the transmission)
5	5106040	1	NUT-HEX-NYLK, .250"-20 SS188
6	5106067	1	WSHR-STL, FLT .281" X .625" X .050" IS SS188
7	5106145	1	METER, TACH/HOUR INDUCTIVE PICKUP
8	5106214	1	SCR-CAP, HEX .250"-20 X .750" SS188
1000	-----	0	Connects to Engine Ground
1001	-----	0	Connects to Engine Magneto

Not For InReproduction

Fuel Tank and Mount Group

Note: Unless noted otherwise, use the standard torque specifications

Mfg. No: 5901752

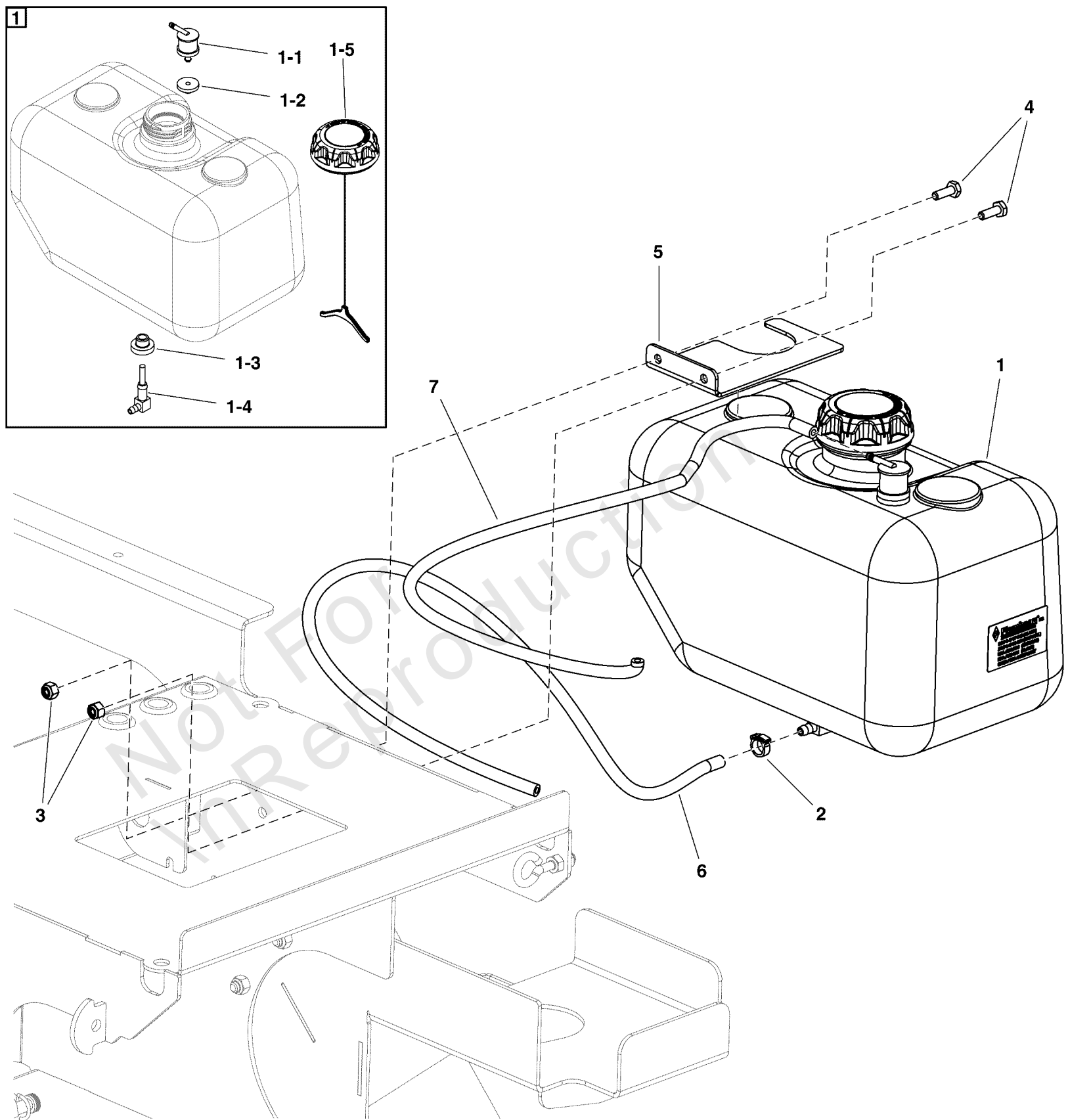

Fuel Tank and Mount Group

REF NO	PART NO	QTY	DESCRIPTION
1	5105974	1	TANK, FUEL 2.5 GAL EPA/CARB -(Includes items 1-1 through 1-5)
1-1	5106225	1	VALVE, SLOSH (C0155) -(SV)
1-2	5106176	1	GROMMET, SLOSH VALVE (C0156) -(SV)
1-3	5105885	1	GROMMET, VALVE, FUEL TANK (B0142) -(SV)
1-4	5105993	1	FITTING, FUEL TANK (B0115) -(SV)
1-5	-----	1	FUEL CAP -(SV)
2	5106037	1	CLAMP, 3/16 FUEL LINE
3	5106040	2	NUT-HEX-NYLK, .250"-20 SS188
4	5106214	2	SCR-CAP, HEX .250"-20 X .750" SS188
5	5106295	1	BRACKET, HOLD DOWN, FUEL TANK
6	5418426	1	LINE, FUEL 3/16" ID X 27.0"
7	5418428	1	HOSE, FUEL VENT EPA 3/16" ID

Handlebar Group

Note: Unless noted otherwise, use the standard torque specifications

Mfg. No: 5901752

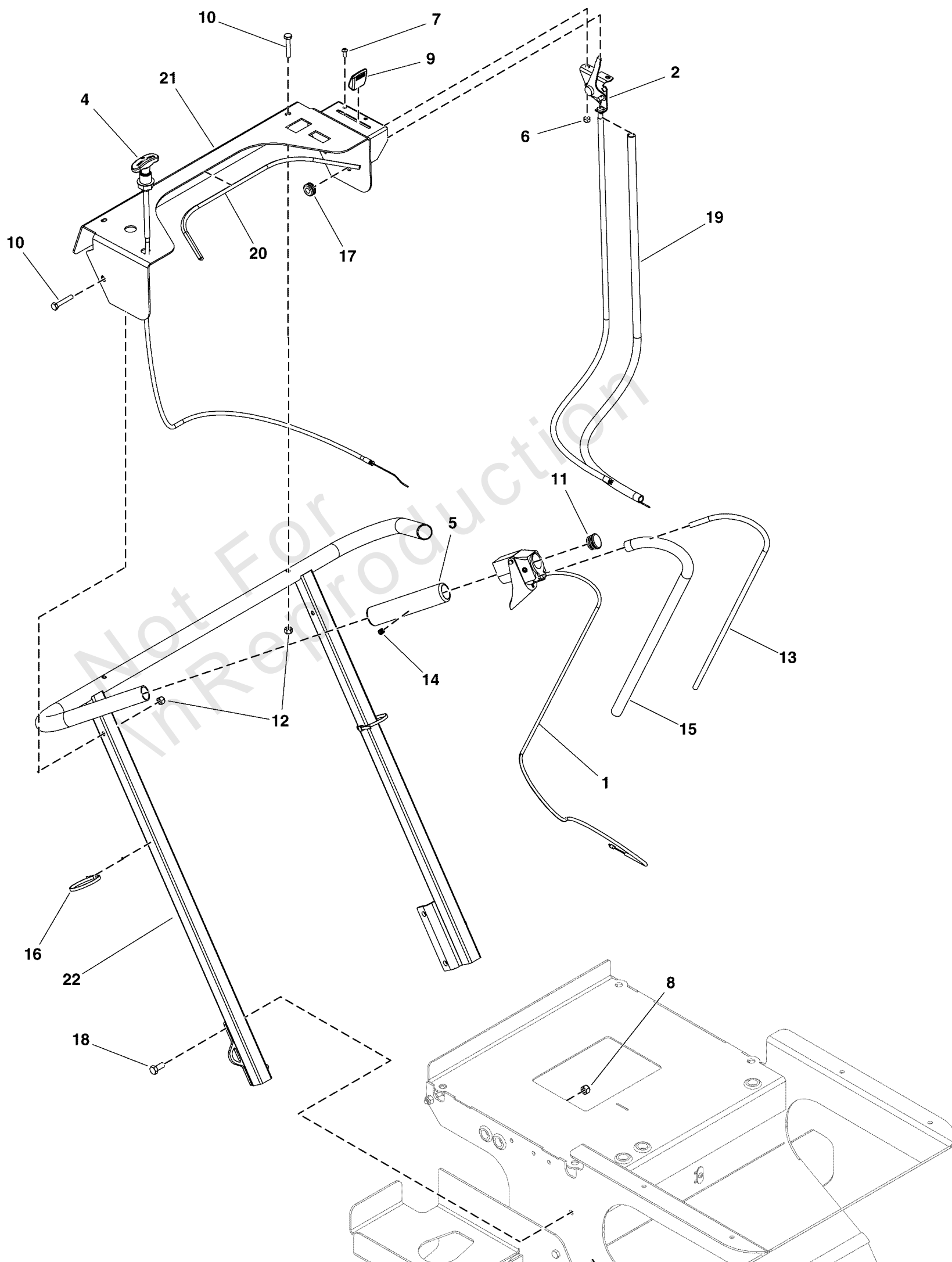

Handlebar Group

REF NO	PART NO	QTY	DESCRIPTION
1	5105876	1	CABLE, THROTTLE 36" LONG -(Connects to engine.)
2	5105877	1	CABLE, POSITIVE ACTION CONTROL 34" LONG -(Connects to gate assembly.)
3	5105881	1	CABLE, PATHFINDER SPRAY
4	5105892	1	CABLE, TURN-TO-LOCK 35" LONG -(Connects to gate assembly.)
5	5105928	2	GRIP, .94 ID X .155 THK X 5.75 LONG
6	5105963	2	NUT-HEX-NYLK, #10-24 SS188
7	5105978	2	SCR-CAP, BSH #10-24 X .500" SS188
8	5105992	4	NUT-HEX-NYLK, 0.3125"-18 SS188
9	5106000	1	KNOB, GATE LEVER
10	5106021	4	SCR-CAP, HEX .250"-20 X 1.500" SSF593C
11	5106028	2	PLUG, 1" TUBE, ROUND
12	5106040	4	NUT-HEX-NYLK, .250"-20 SS188
13	5106068	2	ROD,CABLE SUPPORT
14	5106185	2	SCR-SH, SET .3125"-18 X .375" KCPT SS188
15	5106204	2	THROTTLE CABLE SPLIT LOOM, .500" ID
16	5106297	2	CABLE TIE, .188" W X 7.50" LNG
17	5106454	1	GROMMET, 0.375" I.D., FIT 0.500" HOLE
18	5106024	4	SCR-CAP, HEX .3125"-18 X .750" SS188
19	5417981	1	GATE CABLE SPLIT LOOM, 28"
20	5418126	1	TRIM, U-CHANNEL 19.70" LONG
21	5418180	1	WELD, OPERATOR HANDLEBAR FRAME
22	5418181	1	WELD, FRAME, HANDLE BAR

Hopper Gate Assembly Group (120 LBS)

Note: Unless noted otherwise, use the standard torque specifications

Mfg. No: 5901752

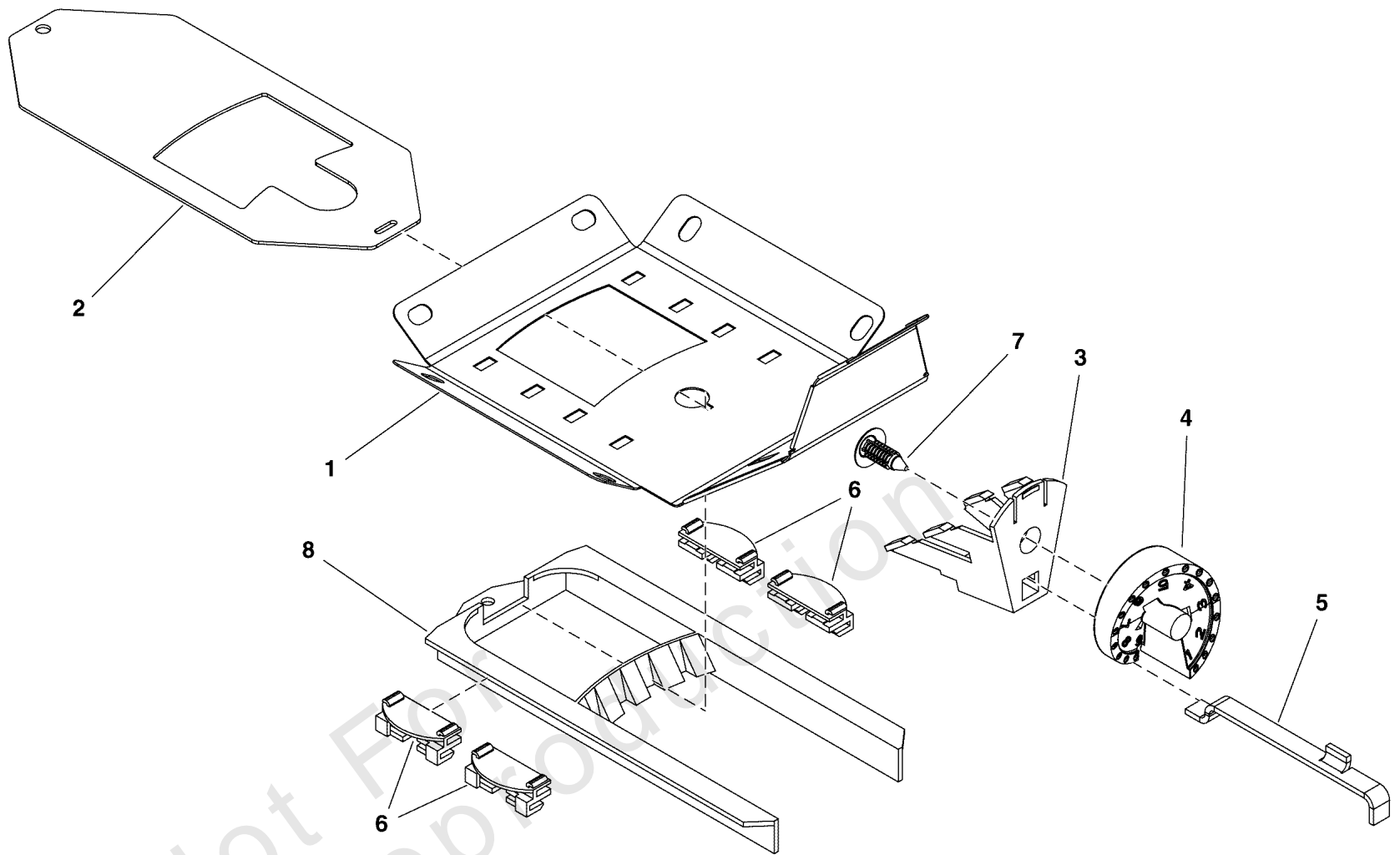

Hopper Gate Assembly Group (120 LBS)

REF NO	PART NO	QTY	DESCRIPTION
1	5106181	1	PLATE, HOPPER BOTTOM 120 LBS
2	5106199	1	PLATE, RATE GATE
3	5105888	1	MOUNT, SPREADER DIAL
4	5105913	1	DIAL, CONTROLLER
5	5105942	1	PLATE, STOPPER, GATE OPENING
6	5105933	4	GUIDE, RATE GATE & DIFFUSER
7	5105953	1	PINE TREE CLIP, SPREADER FOR DIA .33"
8	5106014	1	BAFFLE, SPREADER DIFFUSER

Not For In Reproduction

Hopper Group (120 LBS)

Note: Unless noted otherwise, use the standard torque specifications

Mfg. No: 5901752

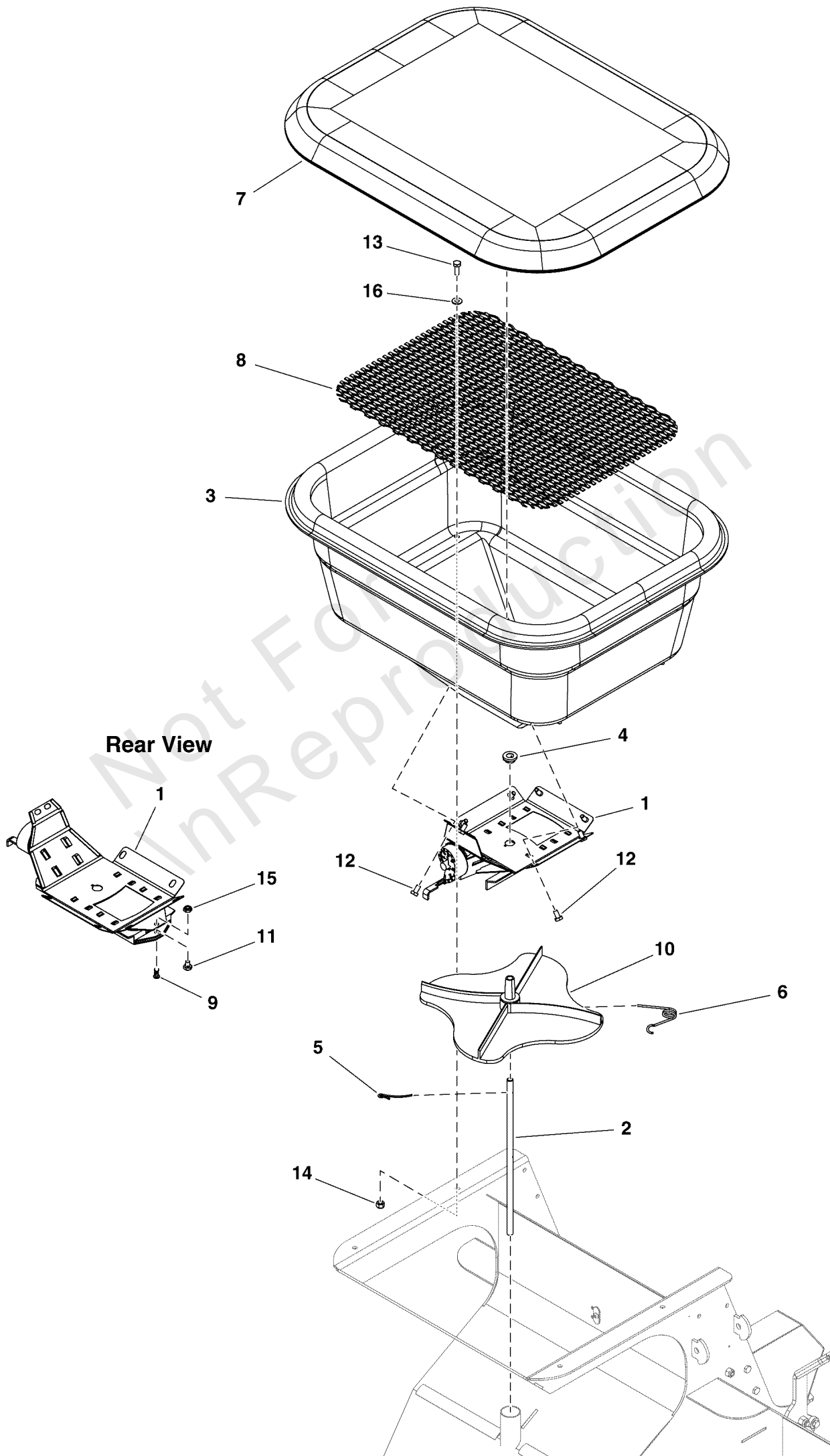

Hopper Group (120 LBS)

REF NO	PART NO	QTY	DESCRIPTION
1	-----	1	ASSM, GATE, COMPLETE (G0104)
2	5105903	1	SHAFT, PLATTER DRIVE
3	5106287	1	HOPPER, 120 LBS
4	5105878	1	BUSHING, HOPPER SPREADER
5	5105875	1	CLIP, SPINNER AGITATOR
6	5105879	1	CLIP, SPREADER SPINNER
7	5105883	1	COVER, HOPPER, MODEL 120
8	5106514	1	SCREEN, HOPPER MODEL 120 LBS
9	5105921	1	FITTING, SWIVEL ACCUWAY
10	5105880	1	PLATE, SPREADER SPINNER
11	5105894	1	SCR-CAP, HEX .250"-20 X .375" SS188 SPC
12	5105893	8	SCR-CAP, HEX .250"-20 X .500" SS188
13	5106214	4	SCR-CAP, HEX .250"-20 X .750" SS188
14	5106040	4	NUT-HEX-NYLK, .250"-20 SS188
15	5105915	1	NUT-HEX-NYLK, .250"-20 TH SS188
16	5106067	4	WSHR-STL, FLT .281" X .625" X .050" IS SS188

Not For In-Plant Production

Main Frame Group

Note: Unless noted otherwise, use the standard torque specifications

Mfg. No: 5901752

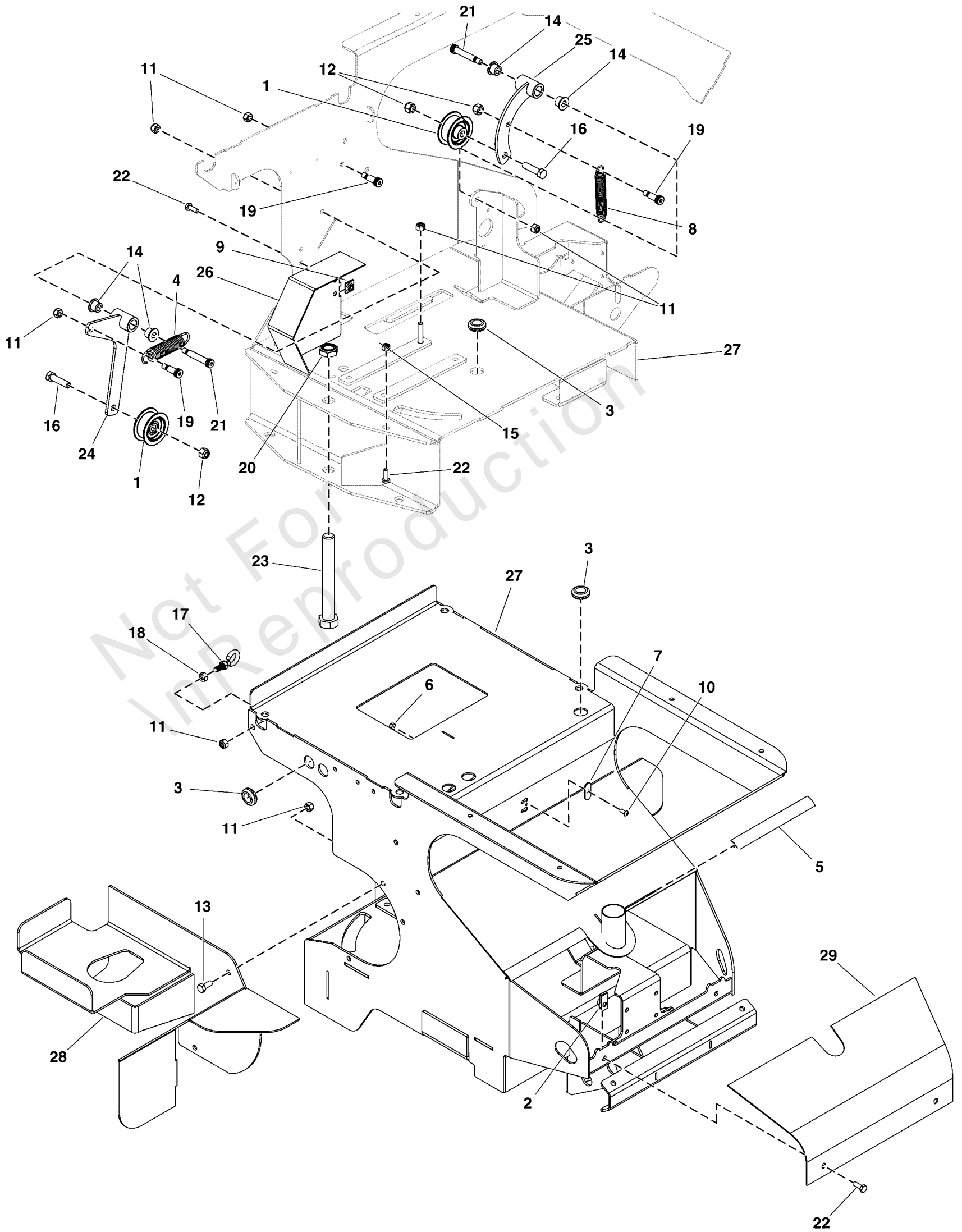

Main Frame Group

REF NO	PART NO	QTY	DESCRIPTION
1	5105890	2	PULLEY IDLER 1.75" OD X 3/8" BORE
2	5105898	2	NUT-CLIP .250"-20 X .781" EDGE DISTANCE
3	5105899	7	GROMMET, .875" HOLE X .625" ID X .125 GROOVE
4	5105946	1	SPRING, EXTENSION .840" OD X 4.00" LONG SS
5	5105954	2	SEAL TRIM, FRONT COWL 6.820" LONG
6	5105963	1	NUT-HEX-NYLK, #10-24 SS188
7	5105969	1	PLATE, CABLE HOLDER
8	5105972	1	SPRING, EXTENSION .64" OD X 4.00" LG SS
9	5105973	2	NUT-CLIP, .250"-20 X .375" EDGE DISTANCE
10	5105978	1	SCR-CAP, BSH #10-24 X .500" SS188
11	5105992	12	NUT-HEX-NYLK, 0.3125"-18 SS188
12	5106006	3	NUT-HEX-NYLK, .375"-16 SS188
13	5106024	3	SCR-CAP, HEX .3125"-18 X .750" SS188
14	5106031	4	BUSHING, FLANGE 3/8 ID X 5/8 OD X 1/2 LG
15	5106040	1	NUT-HEX-NYLK, .250"-20 SS188
16	5106069	2	SCR-CAP, HEX .375"-16 X 1.500" SS188
17	5106082	1	BOLT EYE, .3125"-18 X 1.000" SS188
18	5106159	1	NUT-HEX, .3125"-18 SS188
19	5106172	3	BLT-SLDR, SH .38"X0.75,.313-18 X.50 SS
20	5106184	1	NUT-HEX-NYLK, .750"-10 TH GA ZP
21	5106207	2	BLT-SLDR SH.375"X1.75".3125"-18 X.50" SS188
22	5106214	5	SCR-CAP, HEX .250"-20 X .750" SS188
23	5106215	1	SCR-CAP, HEX .750"-10 X 6.000" SS188
24	5106291	1	WELD, ARM IDLER PATHFINDER
25	5106292	1	WELD, ARM, SMALL IDLER
26	5418065	1	WELD, COVER, PULLEY
27	-----	1	WELD, FRAME
28	5418130	1	WELD, FUEL TANK MOUNT
29	5418874	1	PANEL, FRONT COWL

Operator Platform Group

Note: Unless noted otherwise, use the standard torque specifications

Mfg. No: 5901752

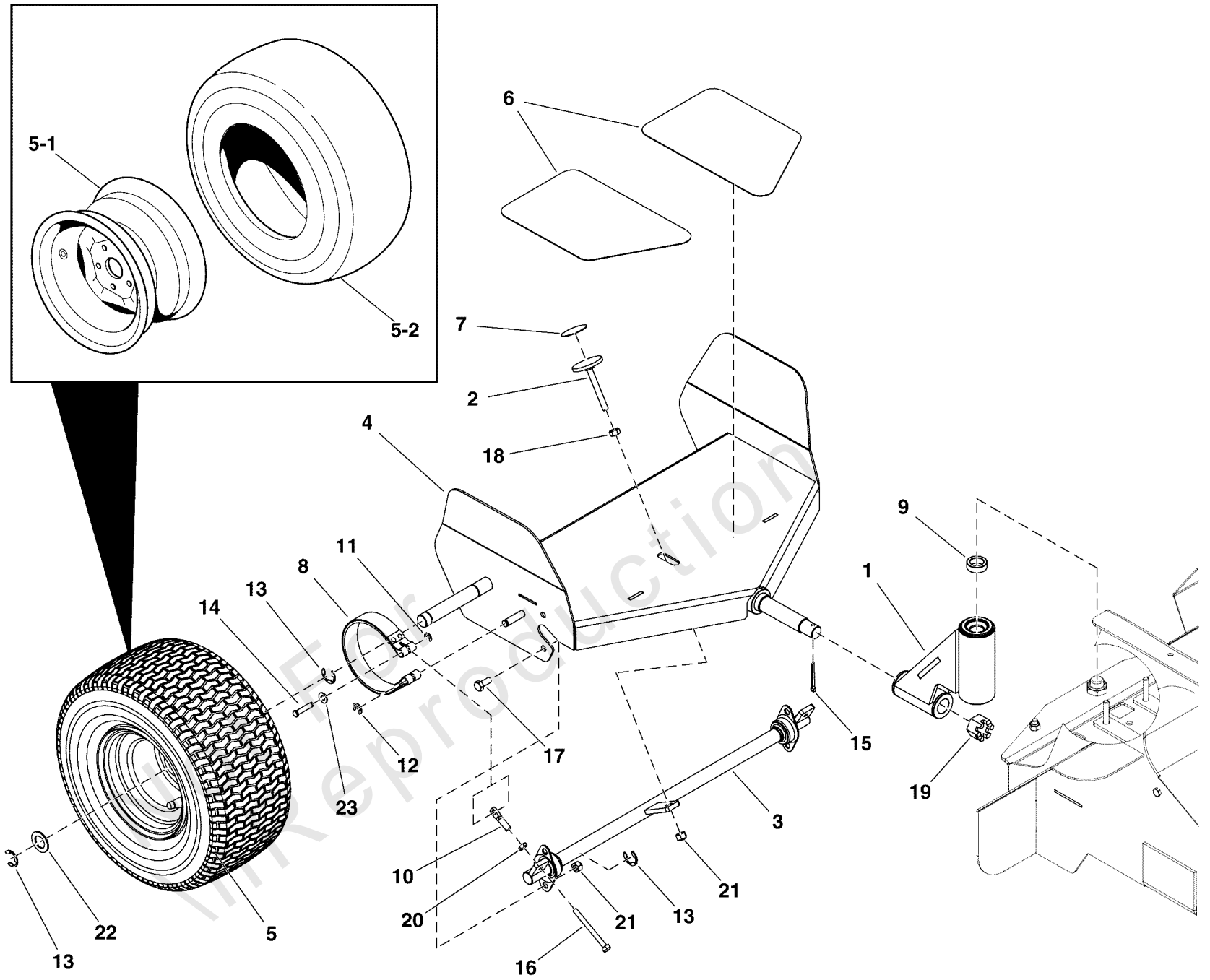

Operator Platform Group

REF NO	PART NO	QTY	DESCRIPTION
1	-----	1	ASSM, TIE, PLATFORM (S0104)
1-1	5417983	1	WELD, HINGE SULKY
1-2	5106004	2	BUSHING, FLANGE 7/8 ID X 1 1/8 OD X 1 LG
1-3	5105967	2	CONE, TPR-ROL Ø.750" ID X Ø1.521" OD x .655" TH
1-4	5105975	2	SEAL, 1.125" BORE X 1.784" OD X 0.469 THK
1-5	5106119	1	ZERK, GREASE .250"-28 SS
2	5106254	1	WELD, BRAKE PEDAL
3	5106270	1	WELDMENT, BRAKE SHAFT
4	5417972	1	WELD, SULKY FRAME
5	5106759	2	ASM, WHEEL & TIRE 13" X 6.50" - 6 TURF
5-1	5106759X2	1	WHEEL ONLY -(One per tire)
5-2	5106759X1	1	TIRE, 13 X 6.50 - 6 -(One per tire)
6	5105929	1	PADS, NON-SLIP PLATFORM
7	5417967	1	PAD, NON-SLIP ROUND BRAKE
8	5105910	2	BRAKE, BAND 4.00 INCH
9	5105986	2	SPCR-SS, 303 .750" X 1.125" X .375
10	5105995	2	NUT-EYE .250" 20 X 1.500 OAL ZP
11	5106605	2	E-RING, 0.250" SHAFT SSPH
12	5106047	2	E-RING, 0.375" SHAFT YZ
13	5105882	6	E-RING, .750" SHAFT YZ
14	5105984	2	PIN, CVS .250" X 1.125" SS188
15	5106163	1	PIN-CTR, .156" X 1.500" SS188
16	5105965	2	SCR-CAP, HEX .250"-20 X 2.750" SS188
17	5106024	4	SCR-CAP, HEX .3125"-18 X .750" SS188
18	5106159	1	NUT-HEX, .3125"-18 SS188
19	5106203	1	NUT-HEX, CSTL .750"-16 GR2 ZP
20	5105977	2	NUT-HEX, JAM .250"-20 SS188
21	5105992	5	NUT-HEX-NYLK, 0.3125"-18 SS188
22	5105957	2	WSHR-STL, FLT .750"X1.250" X .075" MAB ZP
23	5106067	2	WSHR-STL, FLT .281" X .625" X .050" IS SS188

Parking Brake Group

Note: Unless noted otherwise, use the standard torque specifications

Mfg. No: 5901752

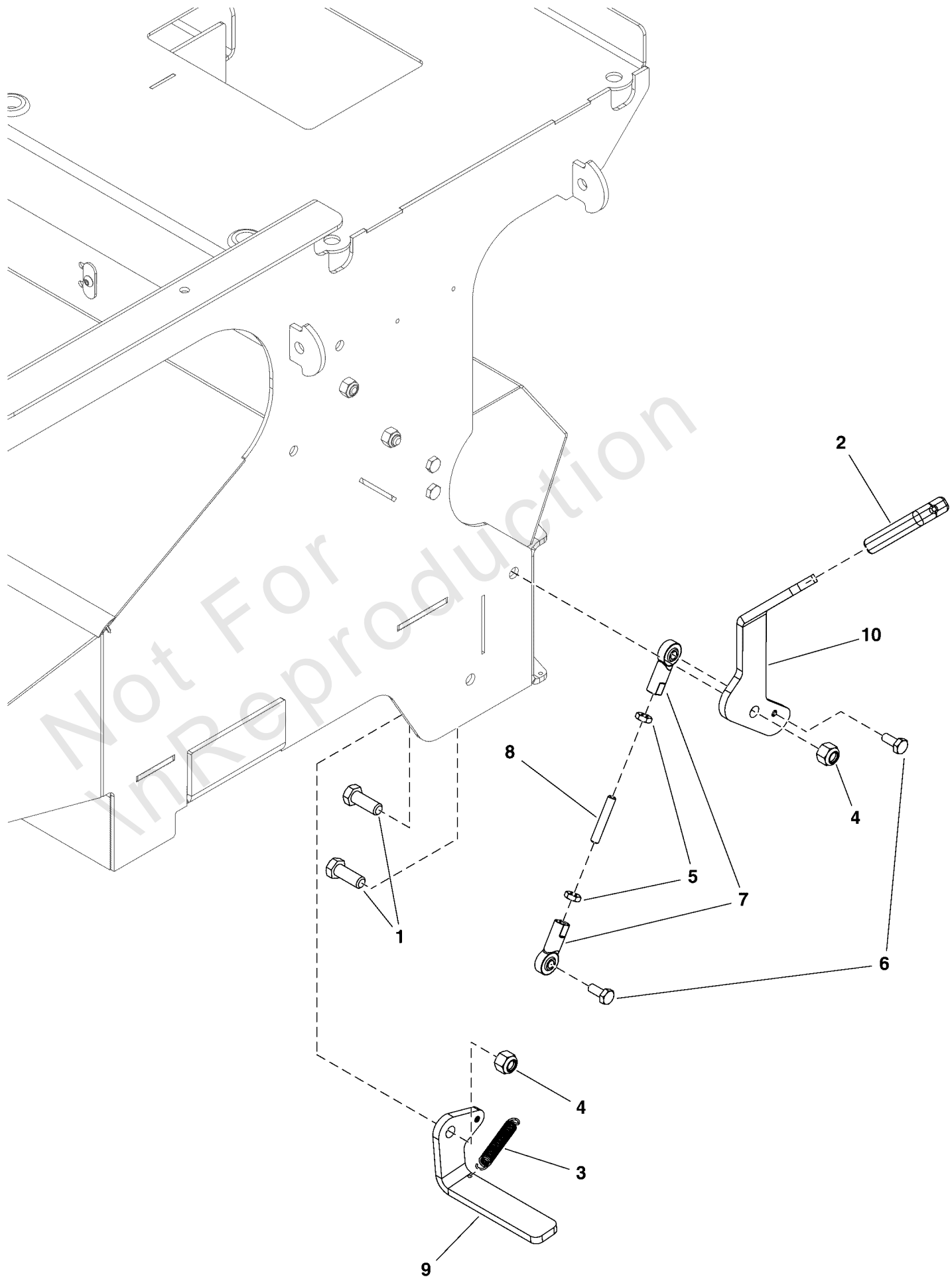

Parking Brake Group

REF NO	PART NO	QTY	DESCRIPTION
1	5025649	2	SCR-CAP, HEX .375"-16 X 1.000" SS188
2	5105900	1	GRIP, .188" X 1.00" ID X .150" THK CLSD CELL FOAM
3	5105982	1	SPRING, EXTENSION .375" OD X 2.500 LONG SS
4	5106006	2	NUT-HEX-NYLK, .375"-16 SS188
5	5106016	2	NUT-HEX, JAM .250"-28 SS188
6	5106029	2	SCR-CAP, HEX .250"-20 X .625" SS188
7	5106173	2	ROD END, FEMALE 1/4-28 RH SS PTFE RACE
8	5106174	1	ROD, THREADED .250"-28 X 1.500" SS188
9	5106280	1	BRACKET, BRAKE BAR
10	5417966	1	HANDLE, PARK BRAKE

Not For InReproduction

Power Transmission Group

Note: Unless noted otherwise, use the standard torque specifications

Mfg. No: 5901752

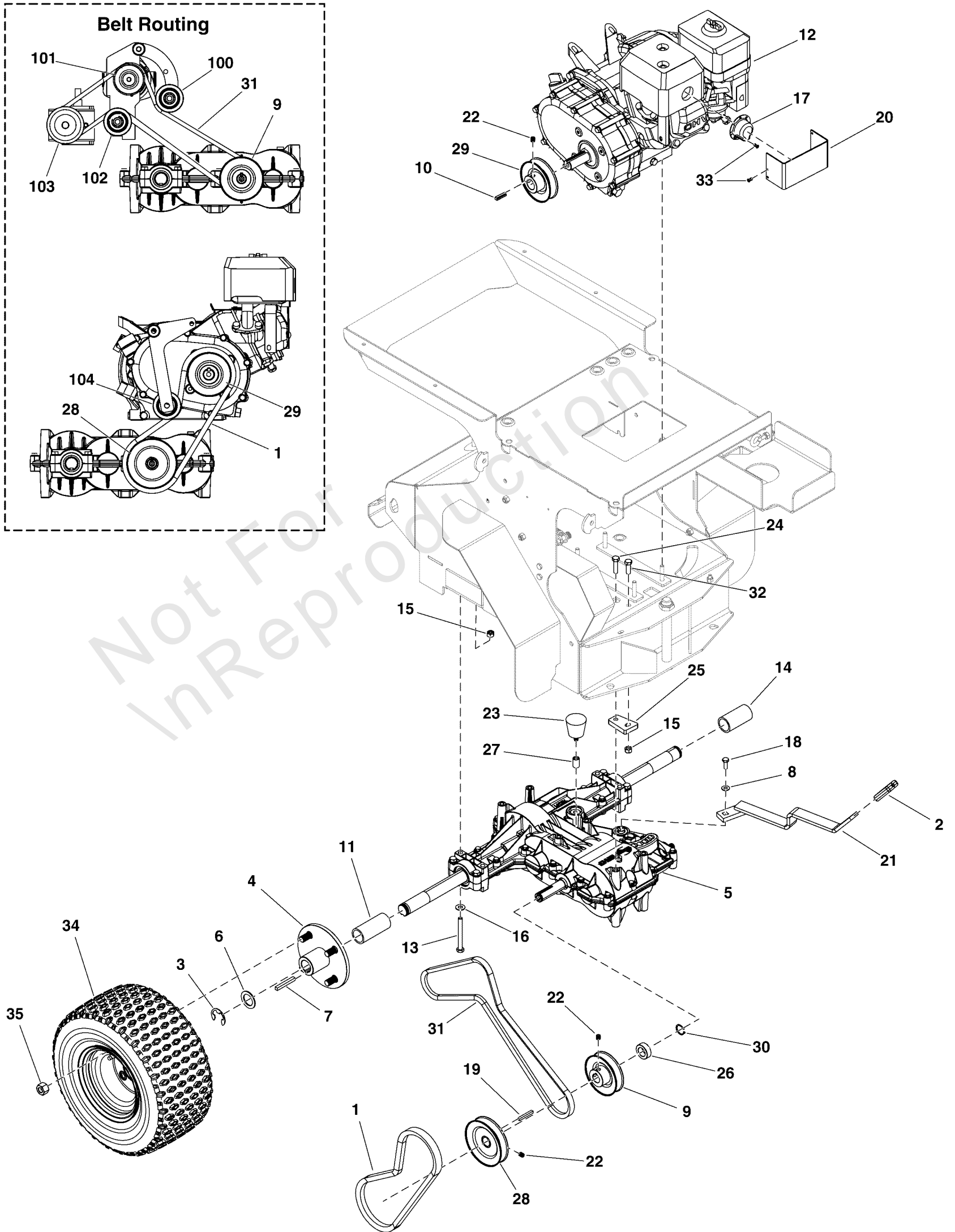

Power Transmission Group

REF NO	PART NO	QTY	DESCRIPTION
1	5105884	1	BELT, V, BX26 29.00 OC
2	5105900	1	GRIP, .188" X 1.00" ID X .150" THK CLSD CELL FOAM
3	5105909	2	E-RING, 1.000" SHAFT YZ
4	5105920	2	HUB, 1.00" BORE 4-BOLT X 4.00" BC
5	5105934	1	TRANSMISSION, PEERLESS 855-007D
6	5105936	2	WSHR-STL, FLT 1.000"X1.500"X.075" MAB ZP
7	5105938	2	KEY, .250" SQ. X 2" SS188
8	5106067	1	WSHR-STL, FLT .281" X .625" X .050" IS SS188
9	5105968	1	PULLEY, 3.50" O.D. x 0.750" I.D. V, A/B
10	5105970	1	KEY, .188"-.250" STEPPED X 1.00" LONG SS 304
11	5105976	1	SPCR-PVC 1.049" X 1.315" X 3.000
12	5105979	1	ENGINE, PATHFINDER/XC
13	5105980	4	SCR-CAP, HEX .3125"-18 X 3.000" SS188
14	5105991	1	SPCR-PVC 1.049" X 1.315" X 2.850"
15	5105992	5	NUT-HEX-NYLK, 0.3125"-18 SS188
16	5106009	4	WSHR-STL, FLT .343" X .750" X .050" SPC SS188
17	5106020	1	DEFLECTOR, EXHAUST HONDA GX160/GX200
18	5106032	1	SCR-CAP, HEX .250"-28 X 0.750" SS188
19	5106038	1	KEY, .188" SQ. X 1.50" SS303
20	5106077	1	PLATE, VALVE MOUNTING
21	5106152	1	WELD, GEAR SHIFT LEVER
22	5106185	6	SCR-SH, SET .3125"-18 X .375" KCPT SS188
23	5106216	1	BUMPER, 1.188OD X 1.50LG W/.3125-18 STUD
24	5106233	1	SCR-CAP, HEX .3125"-18 X 1.250" SS188
25	5106258	1	PLATE, SPACER, TRANSMISSION
26	5106259	1	SPCR-UHMW .765" X 1.250" X .450"
27	5106281	1	SPACER, 0.50" OD X 5/16"-18 THRD X .80" LNG
28	5106498	1	PULLEY, 4.00" O.D. x 0.750" I.D. V, A/B
29	5106499	1	PULLEY, 3.50" O.D. x 0.875" I.D. V, A/B
30	5106526	1	RING, RETAINING EXTERNAL 3/4" ZP
31	5106548	1	BELT, V, A42 44.00 OC
32	5106576	1	SCR-CAP, HEX .3125"-18 X 1.000" SS188
33	5417956	6	RIVET, BLIND .125" X 250" SS188
34	5418044	2	ASM, WHEEL&TIRE 18" X 9.50" W/ANTI-FREEZE
34-1	5105940X1	2	TIRE, 18" TURF -(One per tire)
34-2	5105940X2	2	Wheel Only -(One per tire)
35	5105964	8	NUT-LUG, .500"-20 ZP
100	-----	1	PUMP IDLER PULLEY -(Refer to Main Frame Group)
101	-----	1	PUMP PULLEY -(Refer to Pump and Gearbox Group)
102	-----	1	STATIONARY IDLER PULLEY -(Refer to Pump and Gearbox Group)
103	-----	1	GEARBOX PULLEY -(Refer to Pump and Gearbox Group)
104	-----	1	TRANSAXLE IDLER PULLEY -(Refer to Main Frame Group)

Pump and Gearbox Group

Note: Unless noted otherwise, use the standard torque specifications

Mfg. No: 5901752

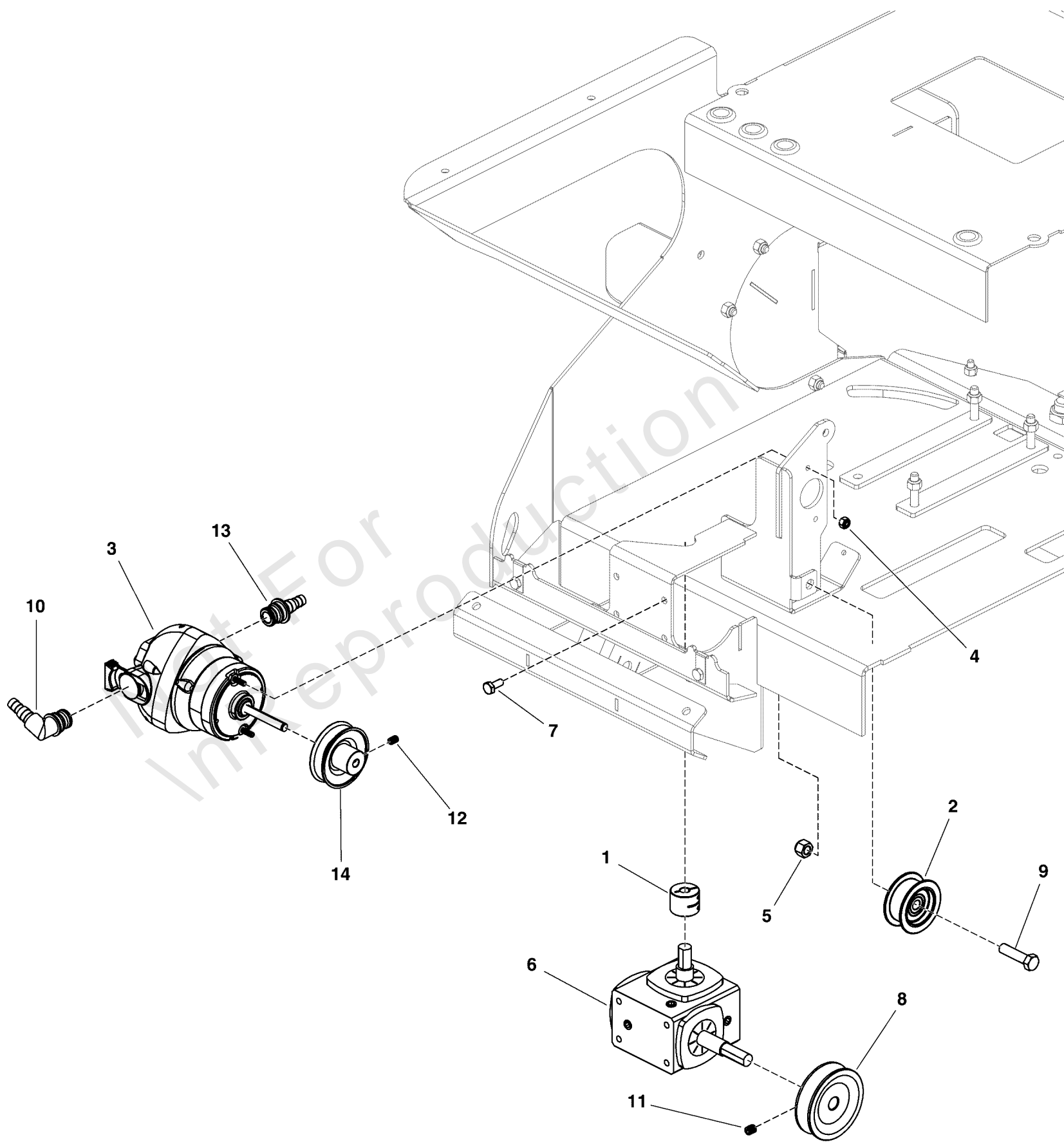

Pump and Gearbox Group

REF NO	PART NO	QTY	DESCRIPTION
1	5105886	1	COUPLER, .500" BORE X .375" BORE SS
2	5105890	1	PULLEY IDLER 1.75" OD X 3/8" BORE
3	5105919	1	PUMP, PULLEY DRIVEN, 1.86 GPM
4	5105963	2	NUT-HEX-NYLK, #10-24 SS188
5	5106006	1	NUT-HEX-NYLK, .375"-16 SS188
6	5108269	1	GEAR REDUCER W/ Ø.375" SHAFT -(Refer to Note: *)
6	5105931	1	GEAR REDUCER W/ Ø.500" SHAFT -(Refer to Note: *)
6	5106013	1	GEAR REDUCER W/ 2.50" LONG Ø.500" SHAFT -(Refer to Note: *)
7	5106029	4	SCR-CAP, HEX .250"-20 X .625" SS188
8	5106041	1	PULLEY, 2.95" O.D. x 0.500" I.D. V, A/B
9	5106069	1	SCR-CAP, HEX .375"-16 X 1.500" SS188
10	5106073	1	FITTING, QUICK RELEASE 3/8 BARB 90 ELBOW
11	5106185	1	SCR-SH, SET .3125"-18 X .375" KCPT SS188
12	5106335	1	SCR-SH, SET .250"-20 X .375" KCPT SS188
13	5106517	1	FITTING, QUICK RELEASE 3/8 BARB STRAIGHT
14	5106741	1	PULLEY, 2.50" OD X .315 ID V, A/B -(Refer to Note: **)

Footnotes:

Note: **Some older models may have featured a pulley and a bushing, the replacement pulley does not require the bushing.

Note: *Measure the gearbox shafts prior to ordering.

Spray System Group

REF NO	PART NO	QTY	DESCRIPTION
1	5105904	2	STRAINER, 50 MESH, POLYPROPYLENE TIP
2	5105905	1	NOZZLE, TURBO FLOODJET BROADCAST, TK-VS5
3	5105914	1	NOZZLE, TURBO TRIM, TT11004VP
4	5105918	2	NOZZLE BODY ADAPTER
5	5105924	2	NOZZLE CAP SEAT GASKET, STANDARD
6	5105932	2	QUICK ATTACH CAP, STANDARD
7	5105948	2	FITTING, 1/4 MALE, 3/8 BARB
8	5105951	14	CLAMP, TUBE 3/8"
9	5106153	1	VALVE, 1/2FNPT, 3-WAY
10	5106158	3	FITTING, 1/4NPT - 3/8 BARB, 90 ELBOW
11	5106183	1	FITTING, TEE 3/8 BARB
12	5418077	1	HOSE, .375 ID, 18" LONG
13	5418095	1	HOSE, SPRAY CONTROL, .375 ID, 32" LONG
14	5418151	1	HOSE, .375 ID, 8" LONG
15	5418152	1	HOSE, .375 ID, 13" LONG
16	5418153	1	HOSE, .375 ID, 16" LONG
17	5418156	1	HOSE, NARROW SPRAY, .375 ID, 51" LONG
18	5418157	1	HOSE, WIDE SPRAY, .375 ID, 49" LONG
19	5418159	1	HOSE, .375 ID, 15" LONG
100	-----	1	Refer to: Tank Spray Group

Spray Tank Group

Note: Unless noted otherwise, use the standard torque specifications

Mfg. No: 5901752

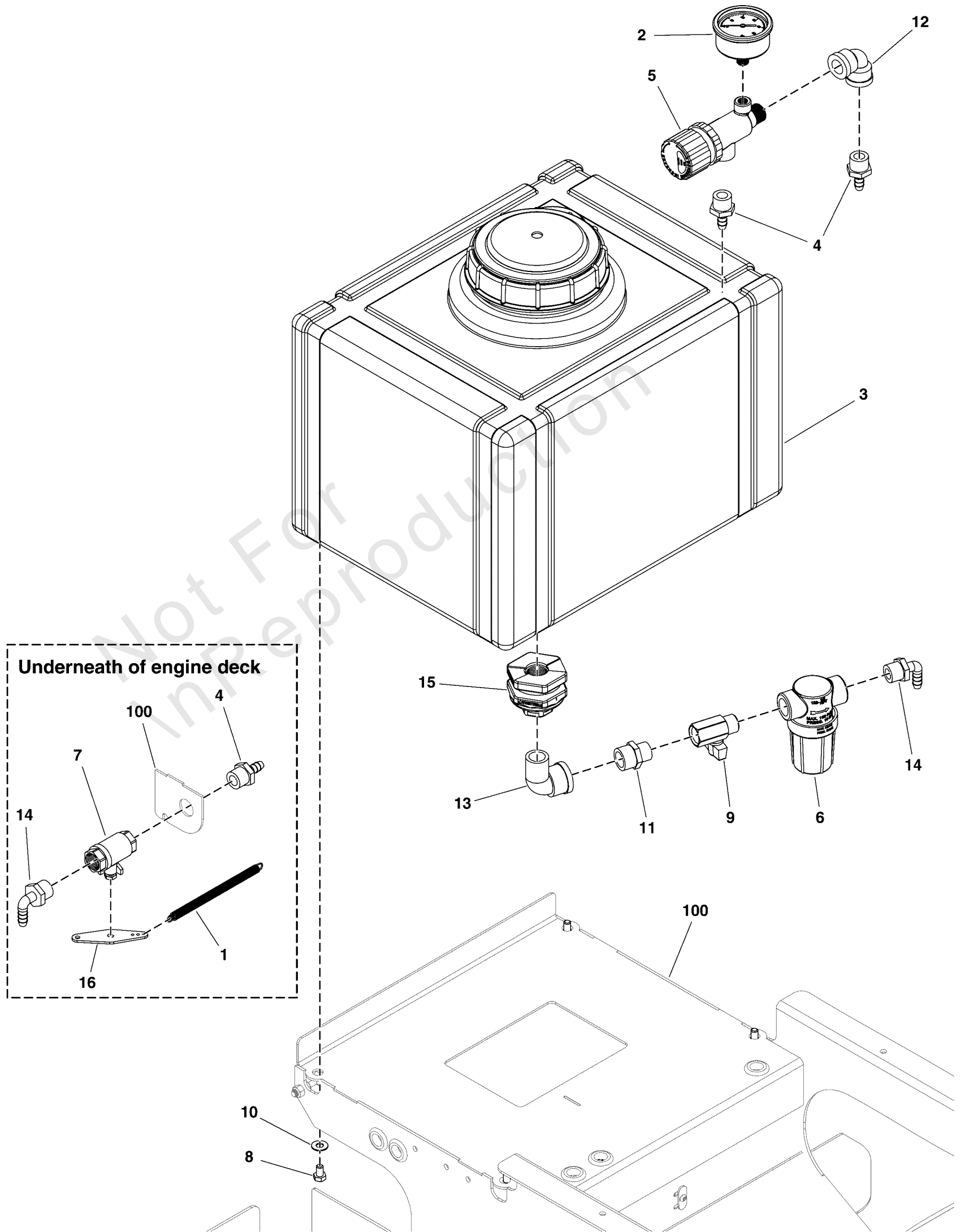

Spray Tank Group

REF NO	PART NO	QTY	DESCRIPTION
1	5105889	1	SPRING, EXTENSION .64" OD X 4.00" LG SS
2	5105941	1	PRESSURE GAUGE, 60 PSI, BACK MOUNT
3	5105949	1	TANK, 12 GAL RT W/SUMP HDPE NAT
4	5105956	3	FITTING, 1/2 MALE, 3/8 BARB
5	5105959	1	PRESSURE RELIEF VALVE, 150PSI
6	5105960	1	STRAINER, LIQUID, IN-LINE, 50 MESH
7	5105962	1	BALL VALVE, 600 PSI
8	5105996	4	SCR-CAP, HEX .3125"-18 X .500" SS188
9	5106003	1	VALVE, BALL, 1/2 MPT - 1/2 FPT
10	5106009	4	WSHR-STL, FLT .343" X .750" X .050" SPC SS188
11	5106059	1	REDUCER BUSHING, 3/4NPT - 1/2NPT, NYLON
12	5106080	1	FITTING, 1/2FNPT - 1/2FNPT, 90 ELBOW
13	5106167	1	FITTING, 3/4NPT - 3/4FNPT, 90 ELBOW
14	5106201	2	FITTING, 1/2MNPT, 3/8 BARB, 90 ELBOW
15	5106288	1	FITTING, TANK BULKHEAD 3/4" POLY
16	5418040	1	PLATE, VALVE ACTUATOR ARM
100	-----	1	FRAME -(Refer to Main Frame Group)

Hardware Identification & Torque Specifications

Torque Specification Chart								
FOR STANDARD METRIC MACHINE HARDWARE (Tolerance ± 20%)								
Property Class	5.6		8.8		10.9		12.9	
	Class 5.6		Class 8.8		Class 10.9		Class 12.9	
Size Of Hardware	in/lbs	Nm.	in/lbs	Nm.	in/lbs	Nm.	in/lbs	Nm.
	ft/lbs		ft/lbs		ft/lbs		ft/lbs	
M3	5.88	.56	13.44	1.28	19.2	1.80	22.92	2.15
M4	13.44	1.28	30.72	2.90	43.44	4.10	52.56	4.95
M5	26.4	2.50	60.96	5.75	5.97	8.10	7.15	9.7
M6	44.64	4.3	7.3	9.9	10.3	14	12.1	16.5
M7	5.2	7.1	12.1	16.5	16.9	23	19.9	27
M8	7.7	10.5	17.7	24	25	34	29	40
M10	15	21	35	48	50	67	59	81
M12	26	36	61	83	86.2	117	103	140
M14	42	58	101	132	136	185	162	220
M16	64	88	147	200	210	285	250	340
M18	89	121	202	275	287	390	346	470
M20	126	171	290	390	405	550	486	660
M22	169	230	390	530	559	745	656	890
M24	217	295	497	375	708	960	840	1140
M27	320	435	733	995	1032	1400	1239	1680
M30	435	590	995	1350	1401	1900	1681	2280
M33	590	800	1349	1830	1902	2580	2278	3090
M36	759	1030	1740	2360	2441	3310	2935	3980
M39	988	1340	2249	3050	3163	4290	3798	5150

Torque Specification Chart						
FOR STANDARD MACHINE HARDWARE (Tolerance ± 20%)						
Hardware Grade	No Marks		SAE Grade 5		SAE Grade 8	
	SAE Grade 2		SAE Grade 5		SAE Grade 8	
Size Of Hardware	in/lbs	Nm.	in/lbs	Nm.	in/lbs	Nm.
	ft/lbs		ft/lbs		ft/lbs	
8-32	19	2.1	30	3.4	41	4.6
8-36	20	2.3	31	3.5	43	4.9
10-24	27	3.1	43	4.9	60	6.8
10-32	31	3.5	49	5.5	68	7.7
1/4-20	66	7.6	8	10.9	12	16.3
1/4-28	76	8.6	10	13.6	14	19.0
5/16-18	11	15.0	17	23.1	25	34.0
5/16-24	12	16.3	19	25.8	29	34.0
3/8-16	20	27.2	30	40.8	45	61.2
3/8-24	23	31.3	35	47.6	50	68.0
7/16-14	30	40.8	50	68.0	70	95.2
7/16-20	35	47.6	55	74.8	80	108.8
1/2-13	50	68.0	75	102.0	110	149.6
1/2-20	55	74.8	90	122.4	120	163.2
9/16-12	65	88.4	110	149.6	150	204.0
9/16-18	75	102.0	120	163.2	170	231.2
5/8-11	90	122.4	150	204.0	220	299.2
5/8-18	100	136	180	244.8	240	326.4
3/4-10	160	217.6	260	353.6	386	525.0
3/4-16	180	244.8	300	408.0	420	571.2
7/8-9	140	190.4	400	544.0	600	816.0
7/8-14	155	210.8	440	598.4	660	897.6
1-8	220	299.2	580	788.8	900	1,244.0
1-12	240	326.4	640	870.4	1,000	1,360.0

The guides and ruler furnished below are designed to help you select the appropriate hardware.



Nut, M8

Thread Diameter (mm)

Inside Diameter (in) Threads per inch

Nut, 1/2-16

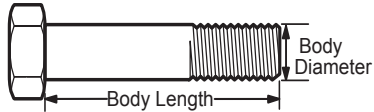

Screw, M8- 1.25 x 25

Thread Diameter (mm) Distance between threads (mm) Body Length (mm)

Body Diameter Threads per inch Body Length (in)

Screw, 1/2- 16 x 2

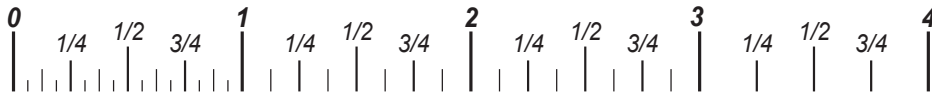

Standard Hardware Sizing

When a washer or nut is identified as 1/2" (M8), this is the *Nominal size*, meaning the *inside diameter* is 1/2 inch (8mm metric thread diameter); if a second number is present it represents the *threads per inch* (distance between threads).

When bolt or capscrew is identified as 1/2 - 16 x 2" (M8 - 1.25 x 50), this means the *Nominal size*, or body diameter is 1/2 inch (8mm metric thread diameter), the second number, 16, represents the *threads per inch*, (*distance between threads*). The final number is the body length of the bolt or screw, 2 inches (50mm).

NOTES

- These torque values are to be used for all hardware excluding: locknuts, self-tapping screws, thread forming screws, sheet metal screws and socket head setscrews.
- Recommended seating torque values for locknuts:
 - for prevailing torque locknuts - use 65% of grade 5 torques.
 - for flange whizlock nuts and screws - use 135% of grade 5 torques.
- Unless otherwise noted on assembly drawings, all torque values must meet this specification.

Common Hardware Types

Hex Head Capscrew

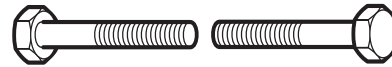

Washer



Carriage Bolt



Hex Nut

Wrench & Fastener Size Guide

1/4" Bolt or Nut Wrench—7/16"	5/16" Bolt or Nut Wrench—1/2"	3/8" Bolt or Nut Wrench—9/16"	7/16" Bolt or Nut Wrench (Bolt)—5/8" Wrench (Nut)—11/16"	1/2" Bolt or Nut Wrench—3/4"
M6 Bolt or Nut Wrench—10mm	M8 Bolt or Nut Wrench—13mm	M10 Bolt or Nut Wrench—17mm	M12 Bolt or Nut Wrench—19mm	M14 Bolt or Nut Wrench—22mm

