



Parts Manual

Mfg. No: 5901755
Venture XC (FS3200) Series Stand-On
Spreader Sprayer



5106065 - Salt Spreader Baffle, 220# (SPB-220-2).....
5601201 - Venture XC Spare Parts Kit (SPK-600-1).....

Not For
In Reproduction

Model Components	Page
Console Pedestal Group.....	4
Electrical Group.....	6
Engine Group.....	8
Foot Pan Group.....	10
Front Caster Group.....	12
Fuel Tank Group.....	14
Hopper Gate Assembly Group (220 LBS).....	16
Hopper Group (220 LBS).....	18
Main Frame Group.....	20
Motion Control Lever Group.....	22
Parking Brake Group.....	24
Power Transmission Group.....	26
Pump / Valve System Group.....	28
Pump Venture Group.....	30
Spray Bar Folding Boom Assembly Group.....	32
Spray Bar Group.....	34
Spray Tank Valve Group.....	36
Spray Toggle Valve Group.....	38
Spray Wand Group.....	40
Sprayer Tank Group.....	42
Spreader Shield Group.....	44
Thigh Pad Group.....	46
Torque Specification Chart.....	48

Not For
In Reproduction

Console Pedestal Group

Note: Unless noted otherwise, use the standard torque specifications

Mfg. No: 5901755

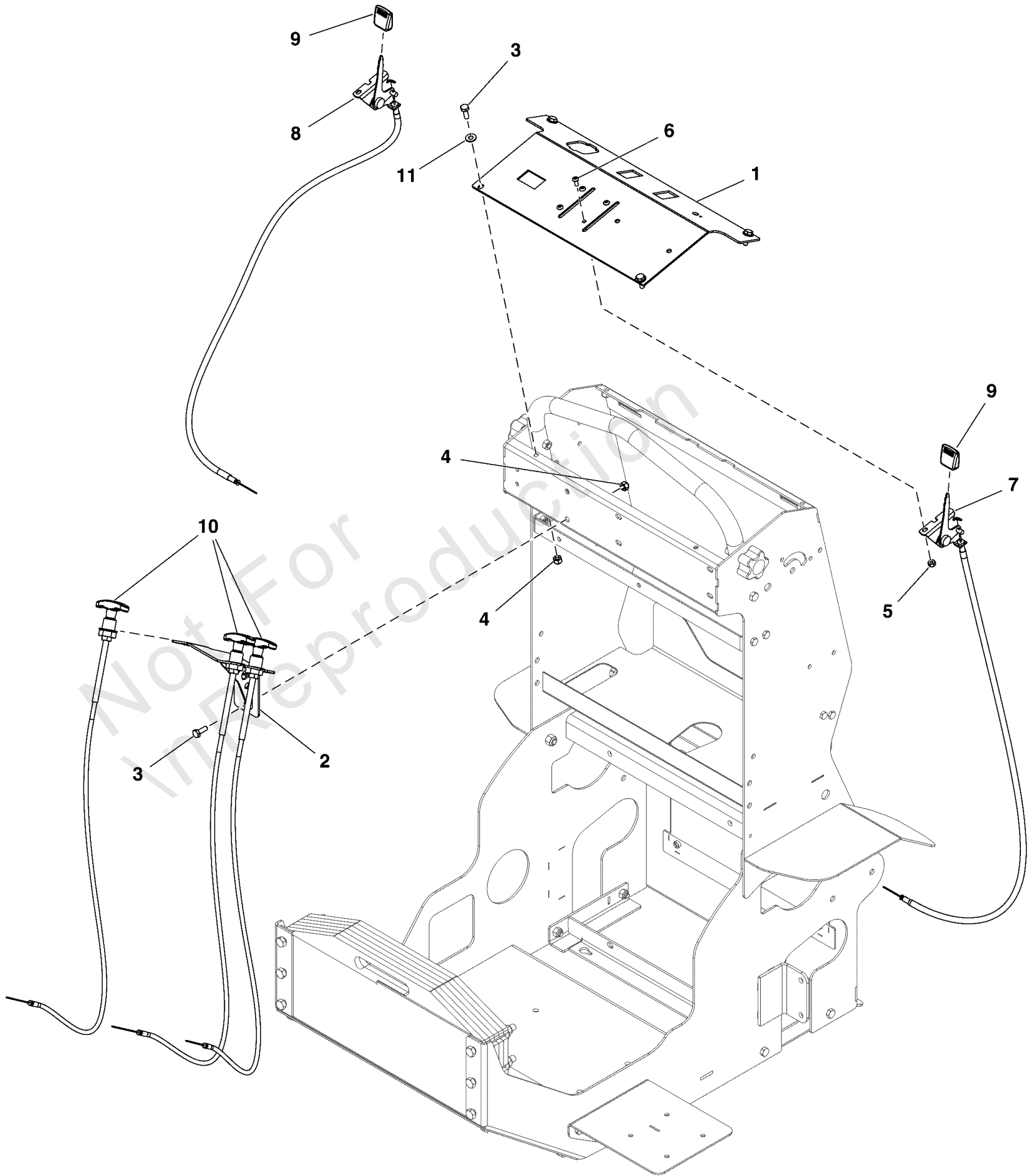

Console Pedestal Group

REF NO	PART NO	QTY	DESCRIPTION
1	5418490	1	PLATE, COVER CONSOLE (SANDED)
2	5418409	1	WELD, BRACKET, HAND CONTROLS
3	5106214	6	SCR-CAP, HEX .250"-20 X .750" SS188
4	5106040	6	NUT-HEX-NYLK, .250"-20 SS188
5	5105963	4	NUT-HEX-NYLK, #10-24 SS188
6	5105978	4	SCR-CAP, BSH #10-24 X .500" SS188
7	5106743	1	CABLE, POS ACTION CONT, CHOKE 36.25" LNG
8	5106744	1	CABLE, POS ACTION CONT, THRTL 35.00" LNG
9	5106000	2	KNOB, GATE LEVER
10	5105892	3	CABLE, TURN-TO-LOCK 35" LONG
11	5106067	4	WSHR-STL, FLT .281" X .625" X .050" IS SS188

Not For InReproduction

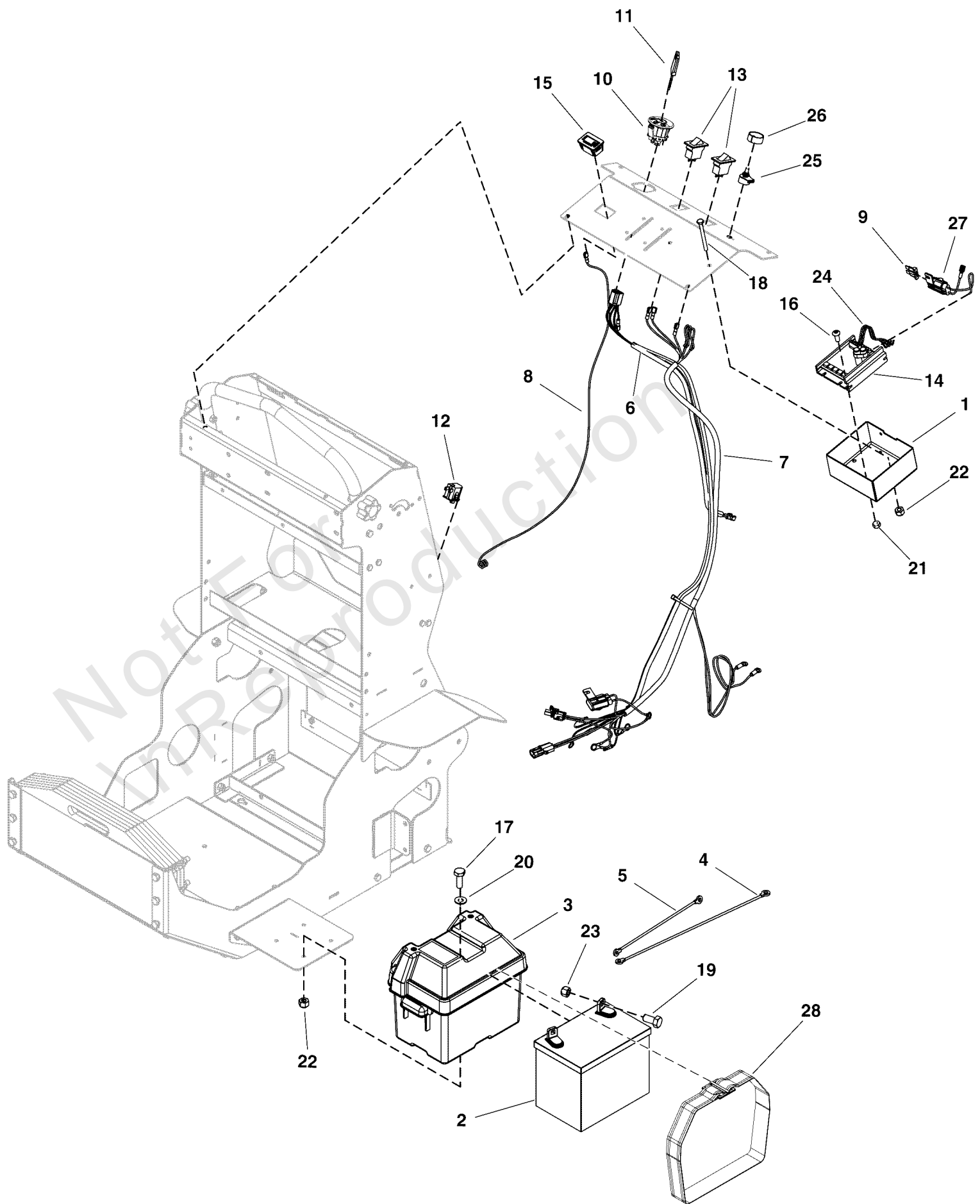

Electrical Group

REF NO	PART NO	QTY	DESCRIPTION
1	5418408	1	COVER, DART CONTROLLER
2	-----	1	BATTERY, 12 Volt, 230 CCA
3	5100688	1	BATTERY BOX, W/ DRAIN HOLE
4	5044471	1	BATTERY CABLE, POSITIVE, 15
5	5044472	1	BATTERY CABLE, NEG, 10, 1/4-5/16
6	5106697	1	HARNESS, IGNITION
7	5106698	1	WIRING HARNESS, PUMP/GEAR MOTOR
8	5106717	1	HARNESS, HOUR METER
9	5106699	2	FUSE, ATOF/ATO, 20A 32V
10	5106193	1	SWITCH, IGNITION 3 POSITION KEY
11	5106252	1	KEY, IGNITION
12	1732004	1	SWITCH, Push Button, NO, Black
13	5106086	2	SWITCH, ROCKER 2P SPST 20A 14VDC
14	5106161	1	DRIVE, LOW VOLTAGE 20A 65E
15	5106145	1	METER, TACH/HOUR INDUCTIVE PICKUP
16	5105978	2	SCR-CAP, BSH #10-24 X .500" SS188
17	5106214	4	SCR-CAP, HEX .250"-20 X .750" SS188
18	5106275	2	SCR-CAP, HEX .250"-20 X 3.000" SS188
19	5106580	2	SCR-CAP, HEX .375"-16 X .750" SS188
20	5106067	4	WSHR-STL, FLT .281" X .625" X .050" IS SS188
21	5105963	2	NUT-HEX-NYLK, #10-24 SS188
22	5106040	6	NUT-HEX-NYLK, .250"-20 SS188
23	5106006	2	NUT-HEX-NYLK, .375"-16 SS188
24	-----	1	HARNESS, SPEED CONTROL TO PCB -(Service with item # 25)
25	5106253	1	POTENTIOMETER, SPEED CONTROL 5K OHM -(Includes potentiometer, nut, washer, and 3 wire leads)
26	5106693	1	KNOB, DART SPEED CONTROL
27	5106681	1	HARNESS, ATO FUSE HOLDER
28	5106544	1	STRAP, BATTERY BOX 45"

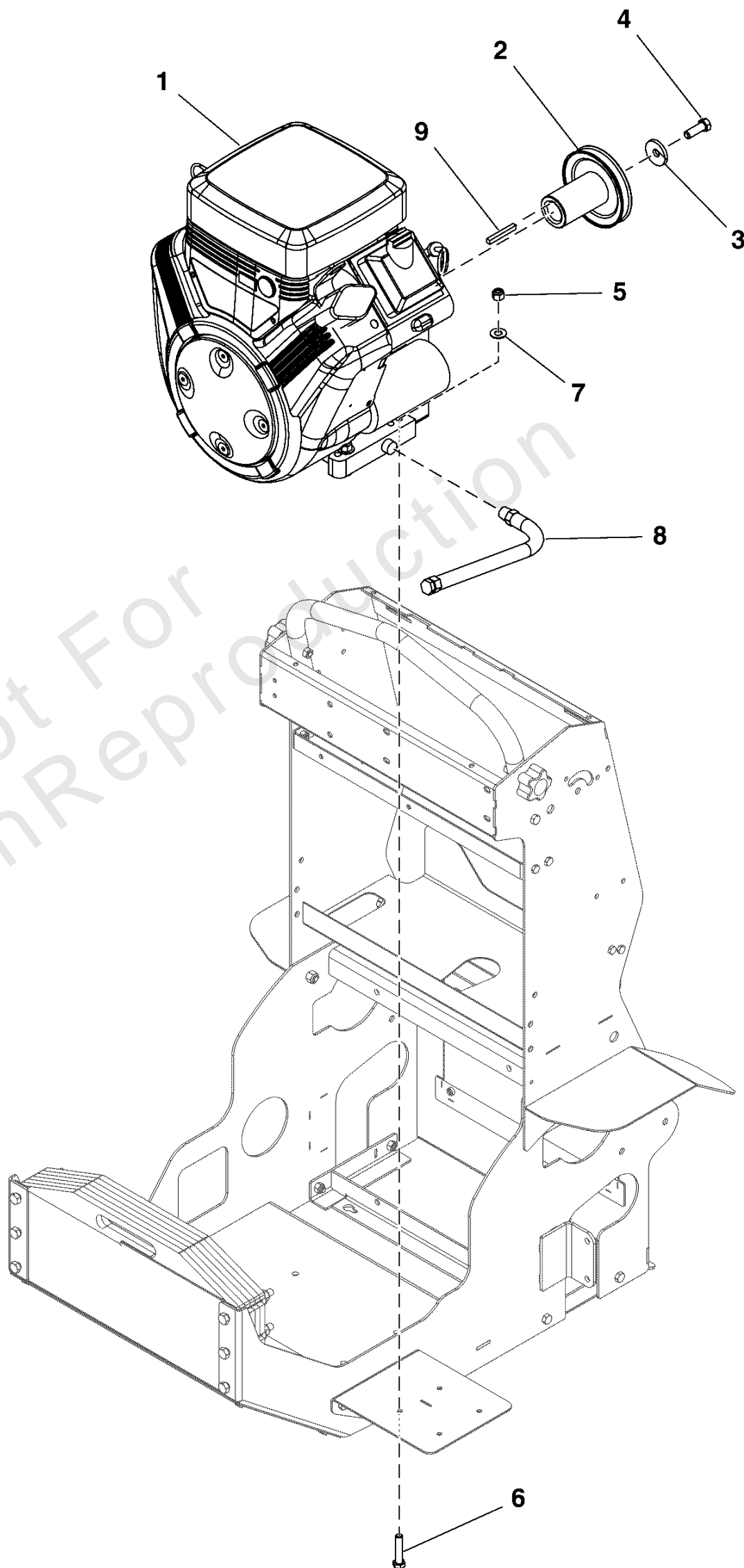

Engine Group

REF NO	PART NO	QTY	DESCRIPTION
1	5106334	1	ENGINE, 18 HP VANGUARD
2	5106332	1	PULLEY, 4.50 O.D. x 1.125" I.D. V, A/B
3	5106653	1	WSHR-STL, BLV, .450" X 1.500" X .172" MZ
4	5106654	1	SCR-CAP, HEX .4375"-20 X 1.250" EP42 G8 YZ
5	5106006	4	NUT-HEX-NYLK, .375"-16 SS188
6	5106518	4	SCR-CAP, HEX .375"-16 X 1.7500" SS188
7	5106168	4	WSHR-STL, FLT .406" X .875" X .050" IS SS188
8	5048681	1	HOSE, OIL DRAIN
9	5105938	1	KEY, .250" SQ. X 2" SS188

Not For In Reproduction

Foot Pan Group

Note: Unless noted otherwise, use the standard torque specifications

Mfg. No: 5901755

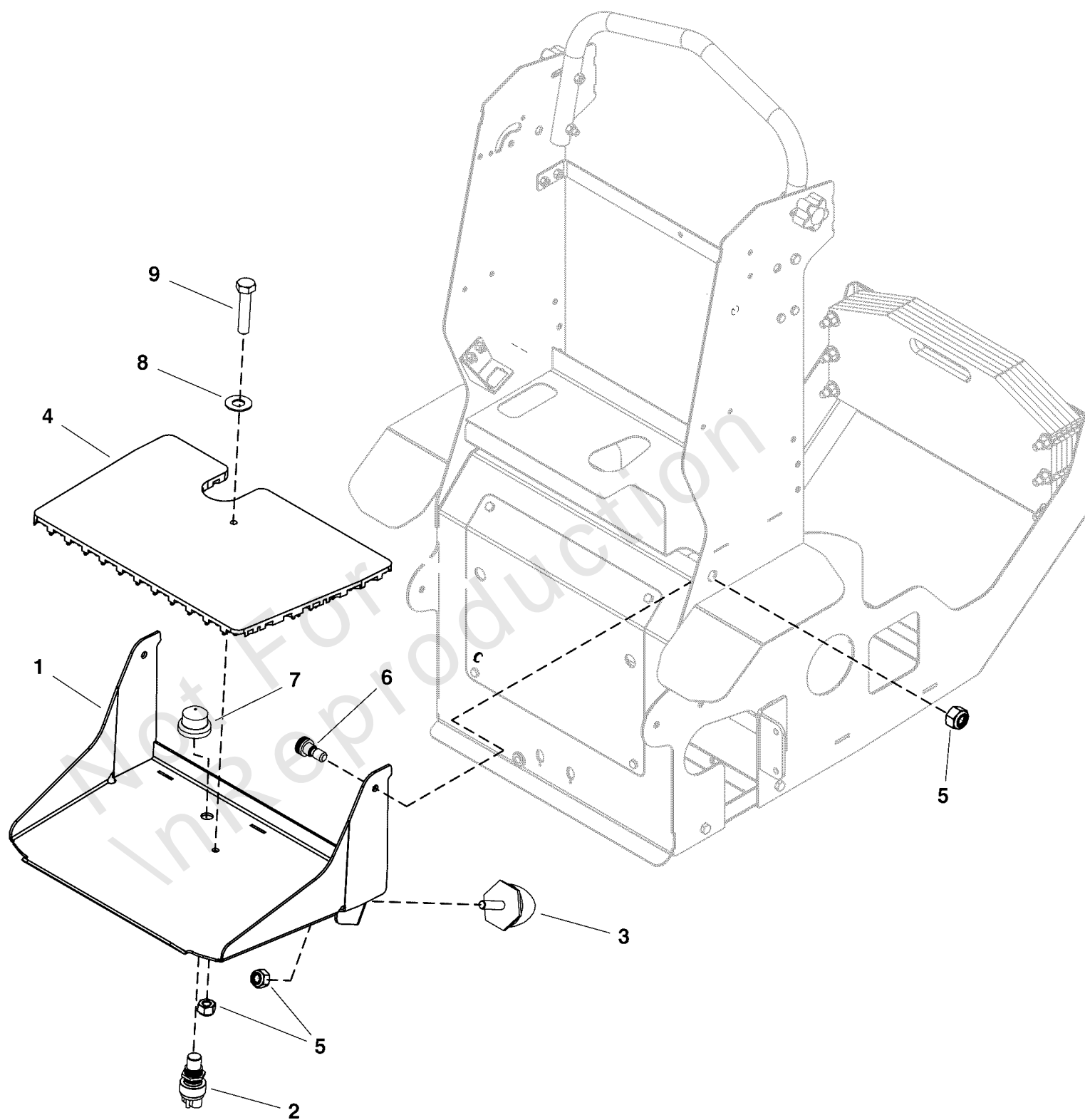

Foot Pan Group

REF NO	PART NO	QTY	DESCRIPTION
1	5418390	1	WELD, FOOTPAN
2	5106144	1	SWITCH, MOMENTARY 60A 12VDC
3	5106694	3	BUMPER, MALE TAPERED 5/16-18 THD, 140 LB
4	5106262	1	PAD, FOOT RUBBER
5	5105992	6	NUT-HEX-NYLK, 0.3125"-18 SS188
6	5106171	2	BLT-SLDR, SH .375" X 0.250", .3125"-18 X.500" SS188
7	5106178	1	BOOT, SWITCH 5/8-32 THREADED
8	5106168	1	WSHR-STL, FLT .406" X .875" X .050" IS SS188
9	5106755	1	SCR-CAP, HEX .3125"-18 X 1.500" SS188

Not For In Reproduction

Front Caster Group

Note: Unless noted otherwise, use the standard torque specifications

Mfg. No: 5901755

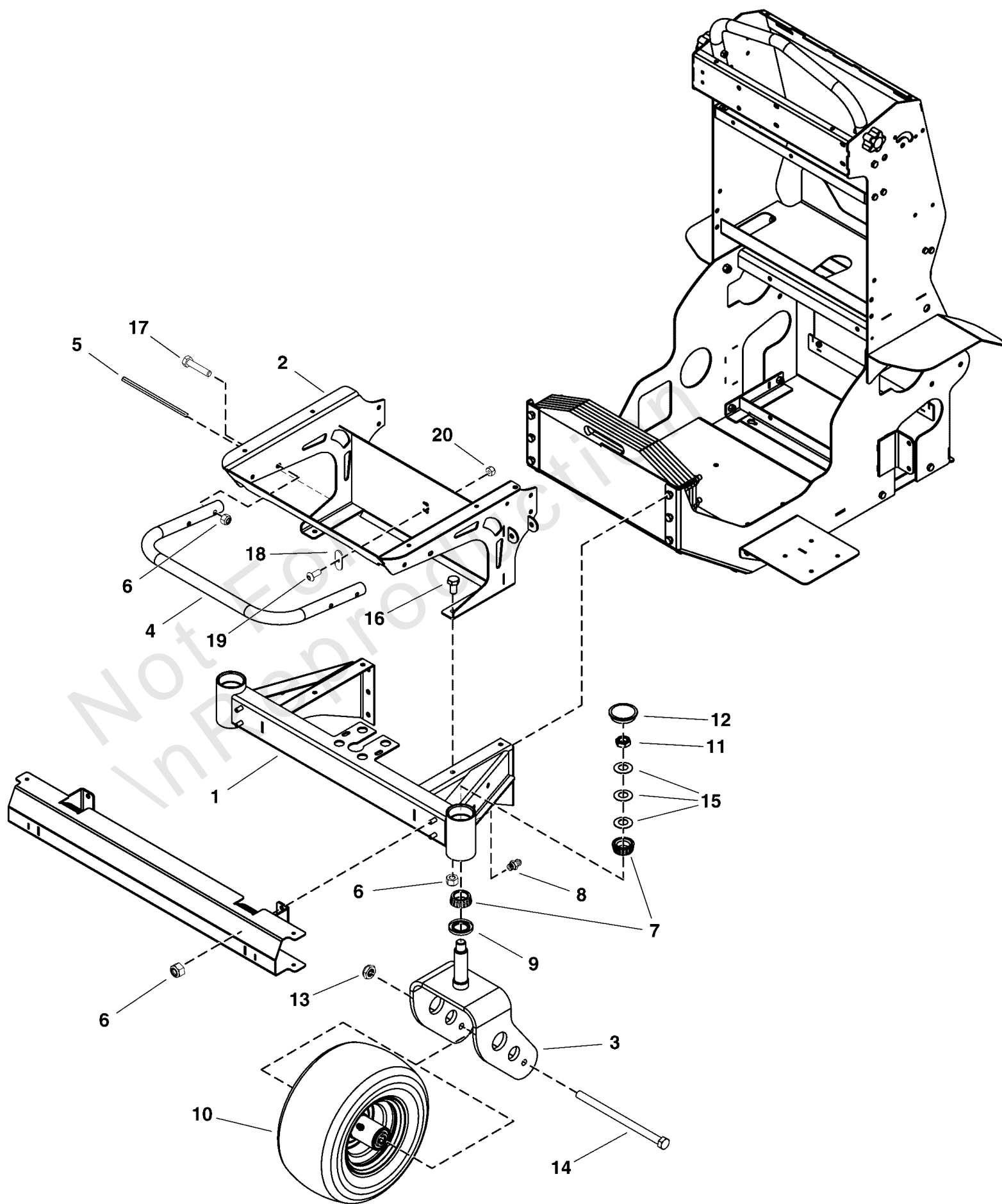

Front Caster Group

REF NO	PART NO	QTY	DESCRIPTION
1	5106272	1	WELD, CASTER ARM SUPPORT
2	5418326	1	WELD, HOPPER SUPPORT
3	5418356	2	WELD, CASTER FORK ASSEMBLY
4	5418341	1	TUBE, FRONT BUMPER
5	5418427	1	TRIM FOR CONSOLE, 7 INCH
6	5105992	12	NUT-HEX-NYLK, 0.3125"-18 SS188
7	5106044	4	BRG, TPR 1.063" ID X .58" THK
8	5106119	2	ZERK, GREASE .250"-28 SS
9	5106126	2	SEAL, 1.125" BORE x 1.987 OD x 0.250 THK
10	5106150	2	ASM, WHEEL & TIRE 13X6.50-6 FILLED SMOOTH
10-1	5108684	2	KIT, 5106150 REPLACEMENT BEARING -(Includes 2 each of bearing, spacer, and seal to service 5106150 tire)
11	5106184	2	NUT-HEX-NYLK, .750"-10 TH GA ZP
12	5106286	2	CAP, 1.970" OD, CASTER GREASE
13	5106582	2	NUT-HEX-NYLK, .500"-13 TH TTW SS188
14	5106583	2	SCR-CAP, HEX .500"-13 X 8.000" SS188
15	5106585	6	WSHR-STL, BLV, .770" X 1.500" X .045" MZ
16	5106649	4	SCR-CAP, HEX .3125"-18 X .625" SS188
17	5106755	4	SCR-CAP, HEX .3125"-18 X 1.500" SS188
18	5105969	1	PLATE, CABLE HOLDER
19	5105978	1	SCR-CAP, BSH #10-24 X .500" SS188
20	5105963	1	NUT-HEX-NYLK, #10-24 SS188

Fuel Tank Group

Note: Unless noted otherwise, use the standard torque specifications

Mfg. No: 5901755

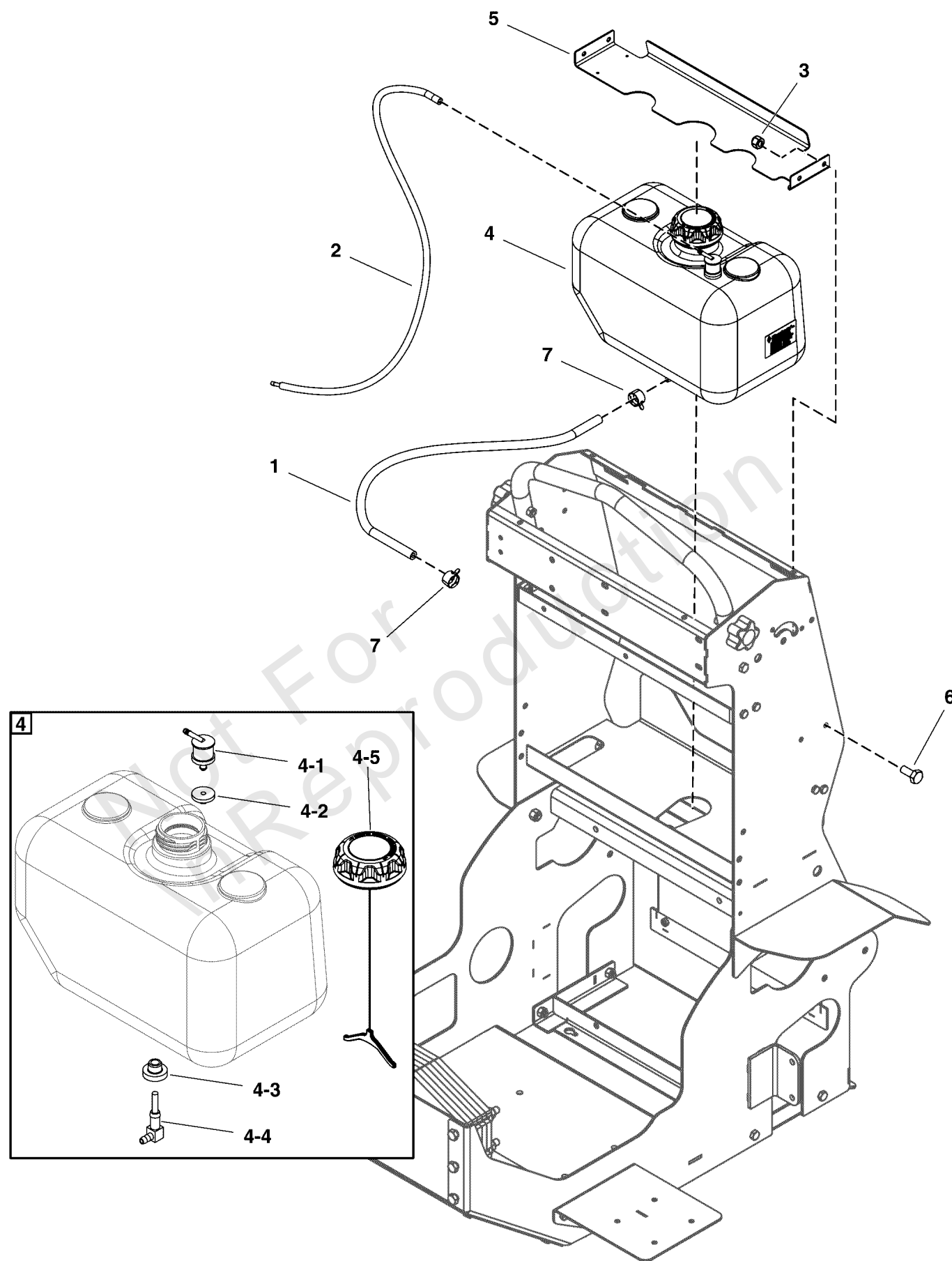

Fuel Tank Group

REF NO	PART NO	QTY	DESCRIPTION
1	5050831X14	1	1/4" Fuel Line, 14" Long -(Connects to Engine)
2	5418428	1	HOSE, FUEL VENT EPA 3/16" ID
3	5106040	4	NUT-HEX-NYLK, .250"-20 SS188
4	5105974	1	TANK, FUEL 2.5 GAL EPA/CARB -(Includes items 1-1 through 1-5)
4-1	5106225	1	VALVE, SLOSH (C0155) -(SV)
4-2	5106176	1	GROMMET, SLOSH VALVE (C0156) -(SV)
4-3	5105885	1	GROMMET, VALVE, FUEL TANK (B0142) -(SV)
4-4	5105993	1	FITTING, FUEL TANK (B0115) -(SV)
4-5	-----	1	FUEL CAP -(SV)
5	5418368	1	BRACKET, FUEL TANK HOLD DOWN
6	5106029	4	SCR-CAP, HEX .250"-20 X .625" SS188
7	791164	2	CLAMP, FUEL LINE 0.50"

Hopper Gate Assembly Group (220 LBS)

Note: Unless noted otherwise, use the standard torque specifications

Mfg. No: 5901755

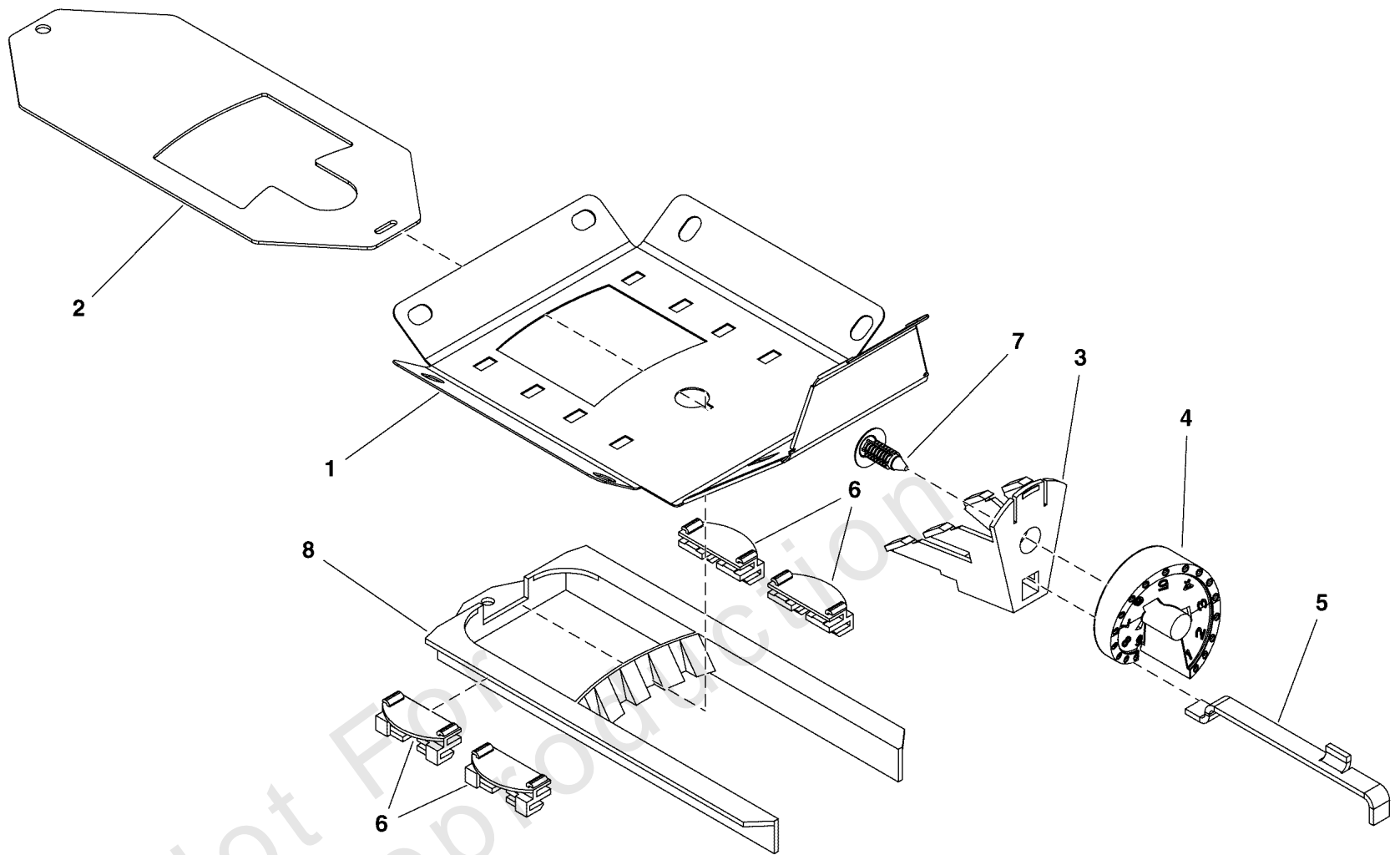

Hopper Gate Assembly Group (220 LBS)

REF NO	PART NO	QTY	DESCRIPTION
1	5106197	1	PLATE, HOPPER BOTTOM 220 LBS
2	5106199	1	PLATE, RATE GATE
3	5105888	1	MOUNT, SPREADER DIAL
4	5105913	1	DIAL, CONTROLLER
5	5105942	1	PLATE, STOPPER, GATE OPENING
6	5105933	4	GUIDE, RATE GATE & DIFFUSER
7	5105953	1	PINE TREE CLIP, SPREADER FOR DIA .33"
8	5106014	1	BAFFLE, SPREADER DIFFUSER

Not For InReproduction

Hopper Group (220 LBS)

Note: Unless noted otherwise, use the standard torque specifications

Mfg. No: 5901755

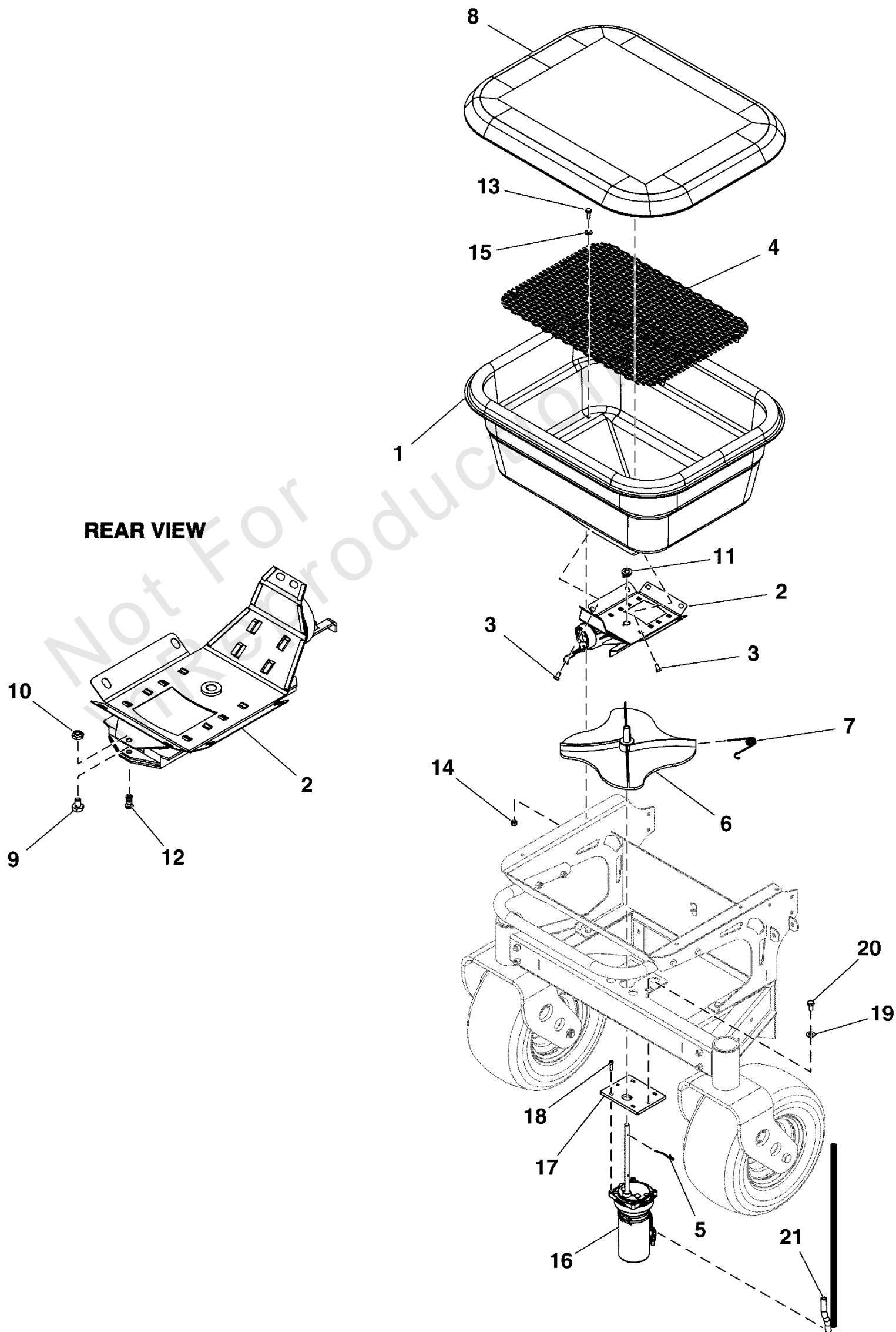

Hopper Group (220 LBS)

REF NO	PART NO	QTY	DESCRIPTION
1	5106211	1	HOPPER, 220 LBS
2	-----	1	ASSEMBLY,GATE,COMPLETE,220#HOPPER(G0172)
3	5105893	8	SCR-CAP, HEX .250"-20 X .500" SS188
4	5106157	1	HOPPER, SCREEN, MODEL 220 LBS
5	5105875	1	CLIP, SPINNER AGITATOR
6	5105880	1	PLATE, SPREADER SPINNER
7	5105879	1	CLIP, SPREADER SPINNER
8	5105887	1	COVER, HOPPER, MODEL 220
9	5105894	1	SCR-CAP, HEX .250"-20 X .375" SS188 SPC
10	5105915	1	NUT-HEX-NYLK, .250"-20 TH SS188
11	5105878	1	BUSHING, HOPPER SPREADER
12	5105921	1	FITTING, SWIVEL ACCUWAY
13	5106214	4	SCR-CAP, HEX .250"-20 X .750" SS188
14	5106040	4	NUT-HEX-NYLK, .250"-20 SS188
15	5106067	4	WSHR-STL, FLT .281" X .625" X .050" IS SS188
16	5106120	1	SPINNER GEARMOTOR (E0118)
17	5418220	1	BRACKET, GEARMOTOR, SUPPORT
18	5106676	4	SCR-CAP SH, #10-32 X .750" SS188
19	5106009	2	WSHR-STL, FLT .343" X .750" X .050" SPC SS188
20	5106649	2	SCR-CAP, HEX .3125"-18 X .625" SS188
21	5418429	1	SPLIT LOOM, .350" ID 19.00" LONG

Main Frame Group

Note: Unless noted otherwise, use the standard torque specifications

Mfg. No: 5901755

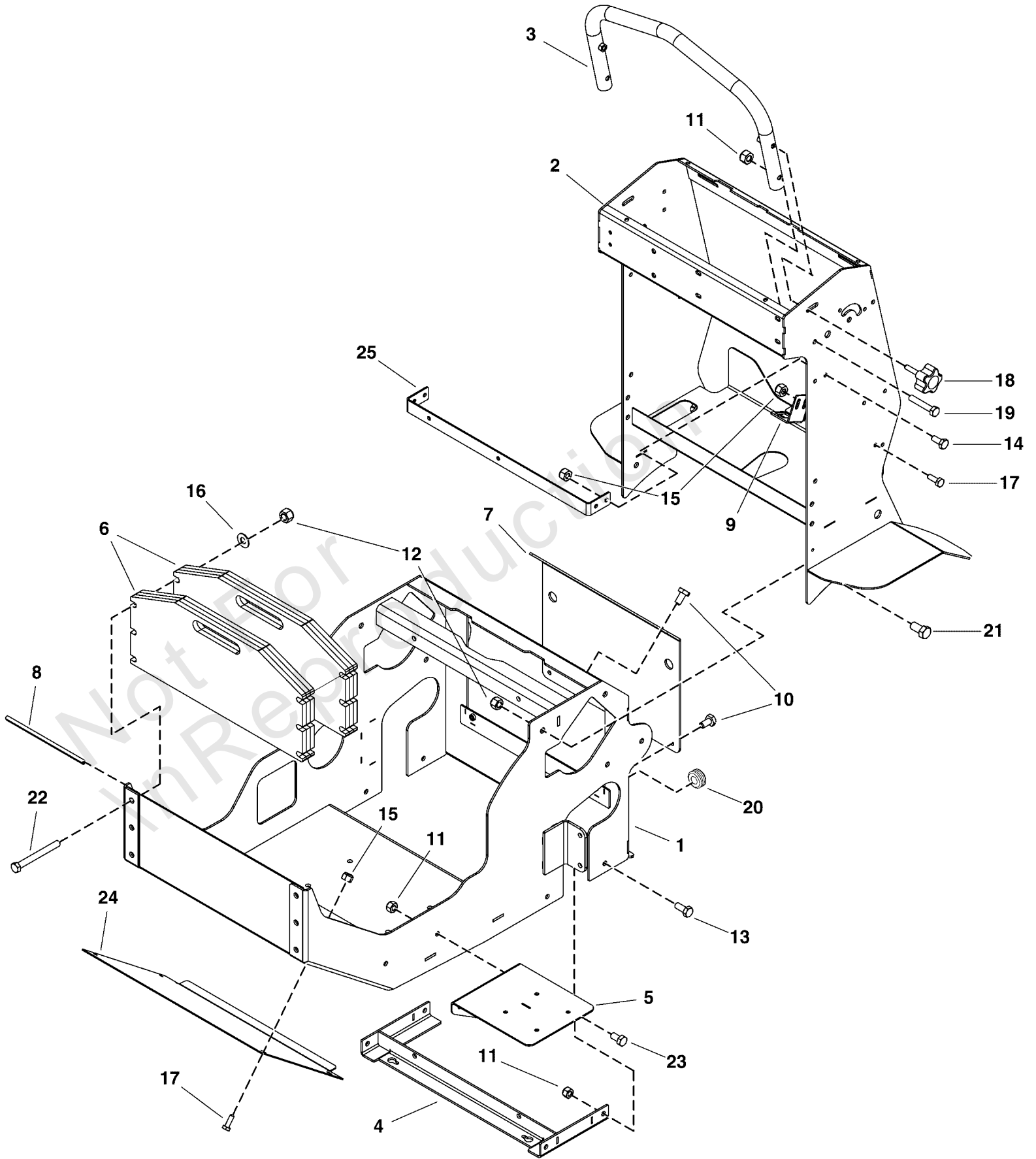

Main Frame Group

REF NO	PART NO	QTY	DESCRIPTION
1	5418316	1	WELD, MAIN FRAME LOWER
2	5418332	1	WELD, HAND CONTROLS
3	5418344	1	WELD, STATIONARY HANDLEBAR
4	5418345	1	WELD, LOWER MOUNT TRANSAXLE
5	5418365	1	WELD, BATTERY SUPPORT PLATE
6	5418384	2	WELD, PLATE COUNTER WEIGHT
7	5418489	1	PLATE, BACK, (SANDED)
8	5418427	1	TRIM FOR CONSOLE, 7 INCH
9	5105788	1	PLATE, PARKING BRAKE SWITCH
10	5105893	4	SCR-CAP, HEX .250"-20 X .500" SS188
11	5105992	8	NUT-HEX-NYLK, 0.3125"-18 SS188
12	5106006	10	NUT-HEX-NYLK, .375"-16 SS188
13	5106024	4	SCR-CAP, HEX .3125"-18 X .750" SS188
14	5106029	4	SCR-CAP, HEX .250"-20 X .625" SS188
15	5106040	10	NUT-HEX-NYLK, .250"-20 SS188
16	5106168	6	WSHR-STL, FLT .406" X .875" X .050" IS SS188
17	5106214	6	SCR-CAP, HEX .250"-20 X .750" SS188
18	5106279	2	KNOB, STATIONARY CONTROL BAR
19	5106293	2	SCR-CAP, HEX .3125"-18 X 1.750" SS188
20	5106454	1	GROMMET, 0.375" I.D., FIT 0.500" HOLE
21	5106580	4	SCR-CAP, HEX .375"-16 X .750" SS188
22	5106648	6	SCR-CAP, HEX .375"-16 X 3.500" SS188
23	5106649	2	SCR-CAP, HEX .3125"-18 X .625" SS188
24	5418325	1	PLATE, FRONT ENGINE COVER
25	5418342	1	BRACKET, EXPANSION TANK MOUNT

Motion Control Lever Group

Note: Unless noted otherwise, use the standard torque specifications

Mfg. No: 5901755

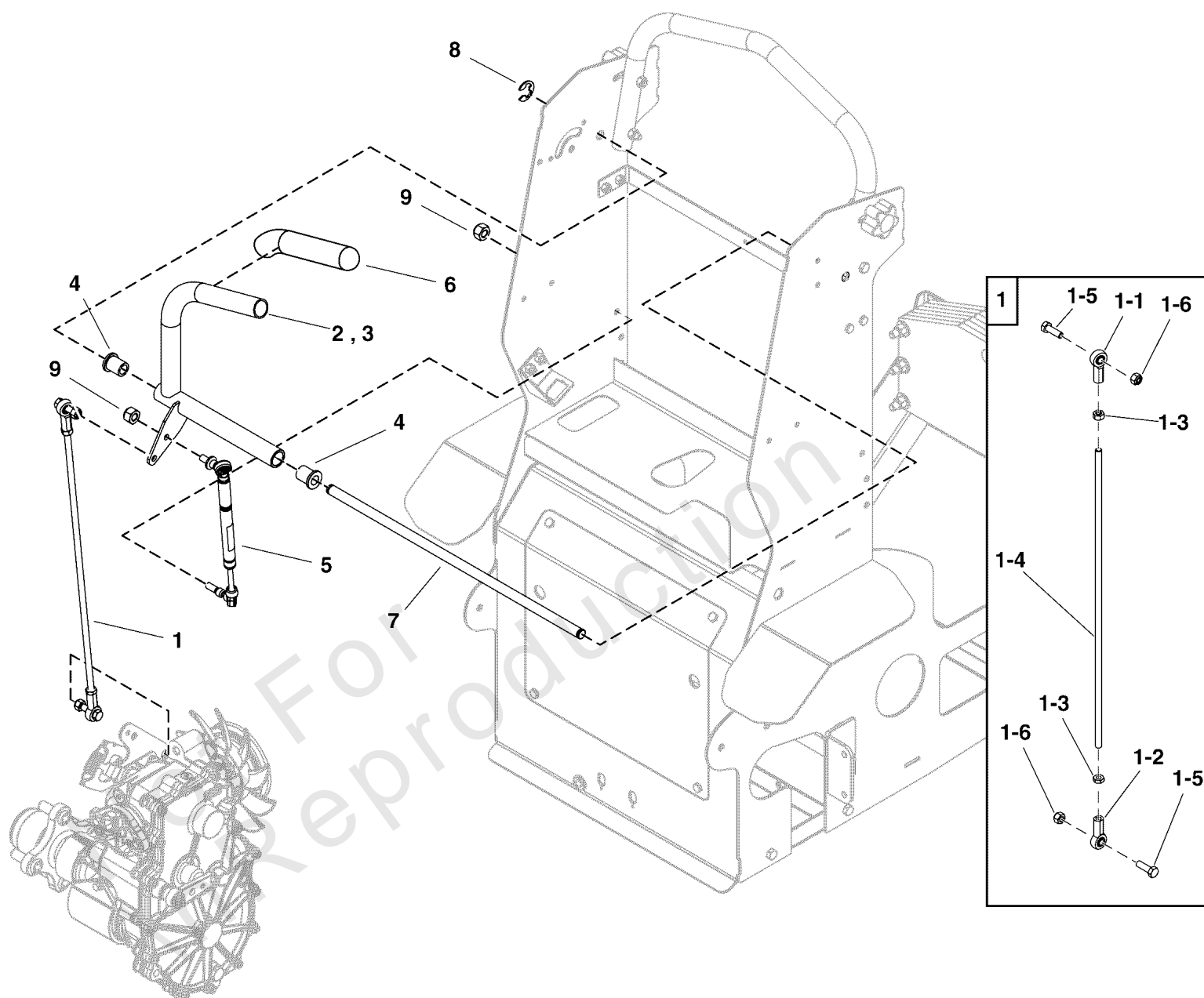

Motion Control Lever Group

REF NO	PART NO	QTY	DESCRIPTION
1	-----	2	ASM, MOTION CONTROL ROD
1-1	5106245	1	ROD END, FEMALE 5/16-24 LH ZP PTFE RACE
1-2	5106244	1	ROD END, FEMALE 5/16-24 RH ZP PTFE RACE
1-3	5106688	2	NUT-HEX, JAM .3125"-24 SS188
1-4	5418378	1	ROD, CONTROL 5/16-24 THD X 18.50" MZ
1-5	5106576	2	SCR-CAP, HEX .3125"-18 X 1.000" SS188
1-6	5105992	2	NUT-HEX-NYLK, 0.3125"-18 SS188
2	5418379	1	WELD, LH CONTROL ARM -(Left Hand Control Arm)
3	5418383	1	WELD, RH CONTROL ARM -(Right Hand Control Arm)
4	5106689	4	BUSHING, FLANGE 1/2 ID X 3/4 OD X 1 LG
5	5106277	2	DAMPER, CONTROL ARM
6	5106278	2	GRIP, MOTION CONTROL
7	5418387	1	ROD, .500" OD MOTION CONTROL
8	5106691	2	E-RING, 0.500" SHAFT YZ
9	5105992	4	NUT-HEX-NYLK, 0.3125"-18 SS188

Parking Brake Group

Note: Unless noted otherwise, use the standard torque specifications

Mfg. No: 5901755

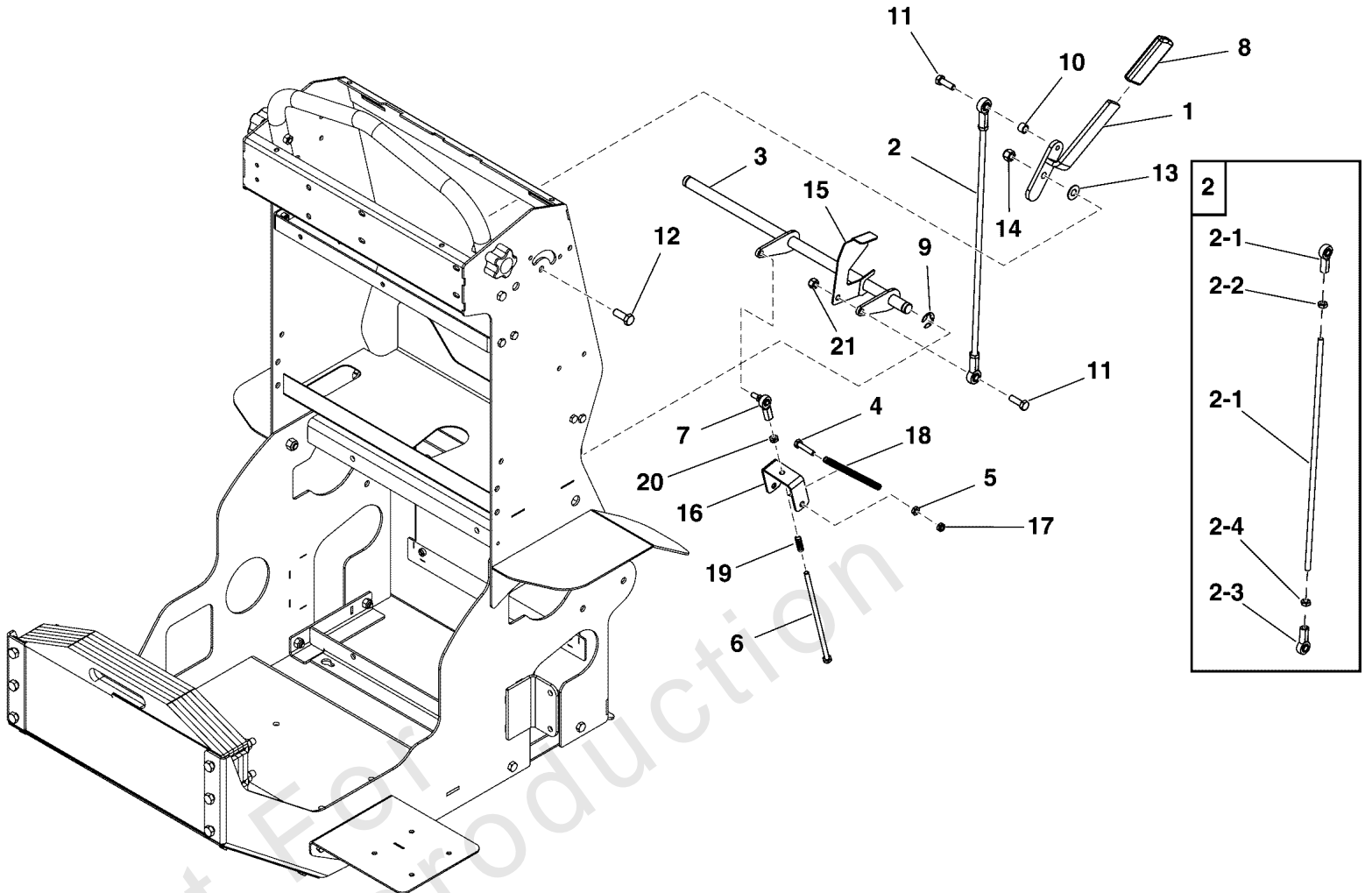

Parking Brake Group

REF NO	PART NO	QTY	DESCRIPTION
1	5418372	1	WELD, PARK BRAKE HANDLE
2	5418375	1	ASM, PARK BRAKE ROD
2-1	5106686	1	ROD, CONTROL 5/16-24 THD X 16.50" MZ
2-2	5106245	1	ROD END, FEMALE 5/16-24 LH ZP PTFE RACE
2-3	5106244	1	ROD END, FEMALE 5/16-24 RH ZP PTFE RACE
2-4	5106688	2	NUT-HEX, JAM .3125"-24 SS188
3	5418369	1	WELD, PARK BRAKE SHAFT ASSEMBLY
4	5106529	2	SCR-CAP, HEX .250"-20 X 1.250" SS188
5	5105977	2	NUT-HEX, JAM .250"-20 SS188
6	5106684	1	SCR-CAP, HEX .250"-28 X 7.000" G5 ZP
7	5106246	1	ROD END, 1/4-28 WITH STUD
8	5105900	1	GRIP, .188" X 1.00" ID X .150" THK CLSD CELL FOAM
9	5106685	2	E-RING, 0.625" SHAFT YZ
10	5106687	1	SPCR-SS, 304 0.375" X 0.500" X .357"
11	5106576	2	SCR-CAP, HEX .3125"-18 X 1.000" SS188
12	5025649	1	SCR-CAP, HEX .375"-16 X 1.000" SS188
13	5106168	1	WSHR-STL, FLT .406" X .875" X .050" IS SS188
14	5106006	1	NUT-HEX-NYLK, .375"-16 SS188
15	5105789	1	PLATE, CONTACT, PARKING BRAKE SWITCH
16	5418376	1	BRACKET, LINKAGE PARK BRAKE
17	5105915	2	NUT-HEX-NYLK, .250"-20 TH SS188
18	5105889	2	SPRING, EXTENSION .64" OD X 4.00" LG SS
19	5106223	1	SPRING, COMPRESSION .36 OD X 1.00 LG SS
20	5106016	1	NUT-HEX, JAM .250"-28 SS188
21	5105992	1	NUT-HEX-NYLK, 0.3125"-18 SS188

Power Transmission Group

Note: Unless noted otherwise, use the standard torque specifications

Mfg. No: 5901755

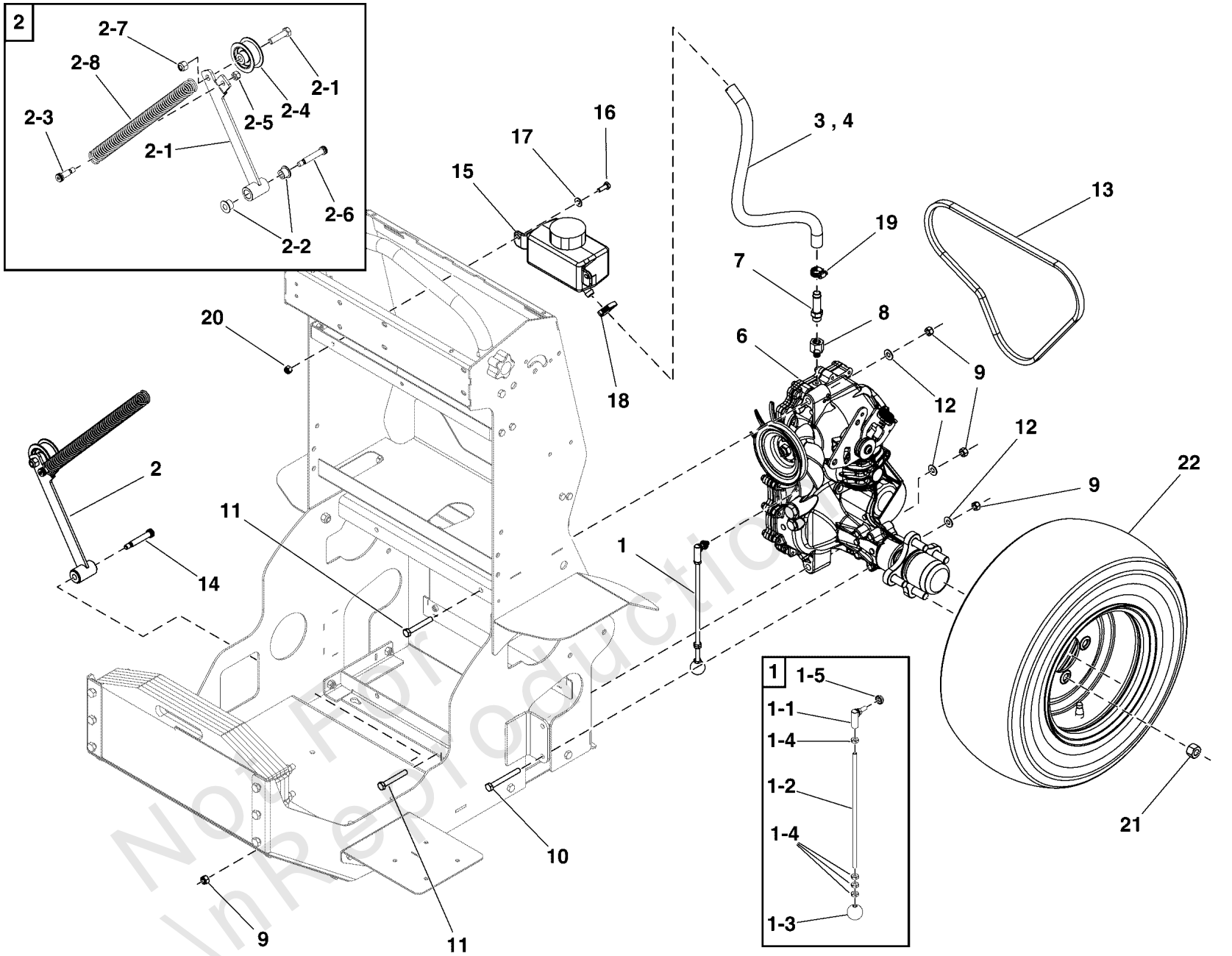

TRANSAXLE PULLEY

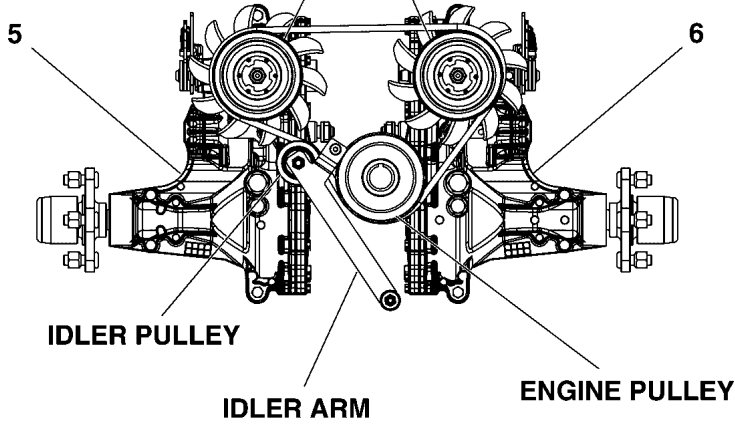

IDLER PULLEY

IDLER ARM

ENGINE PULLEY

**FRONT OF MACHINE
BELT ROUTING**

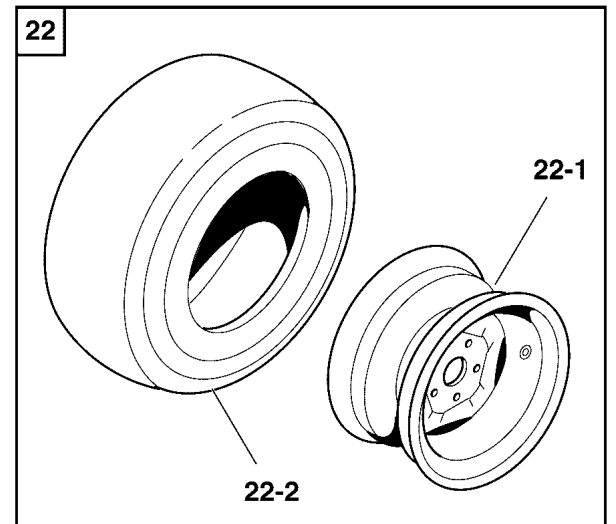

22-2

22-1

Power Transmission Group

REF NO	PART NO	QTY	DESCRIPTION
1	-----	2	ASM, TRANSMISSION RELEASE
1-1	5106658	1	ROD END, FEM 1/4-28 RH SS PTFE RACE STUD
1-2	5106660	1	ROD, CONTROL 1/4-28 THD X 9.00" MZ
1-3	5106659	1	KNOB, BALL 1.000 OD W/1/4-28 INSERT
1-4	5106016	4	NUT-HEX, JAM .250"-28 SS188
1-5	5106742	1	NUT-HEX-FGLK.250"-28 SS188
2	-----	1	ASSY, IDLER ARM
2-1	5106060	1	WELD, IDLER ARM
2-2	5106031	2	BUSHING, FLANGE 3/8 ID X 5/8 OD X 1/2 LG
2-3	5106712	1	BLT-SLDR, SH .375" X 0.750", .3125"-18 X.500" G8ZY
2-4	5105890	1	PULLEY IDLER 1.75" OD X 3/8" BORE
2-5	5105992	1	NUT-HEX-NYLK, 0.3125"-18 SS188
2-6	5106069	1	SCR-CAP, HEX .375"-16 X 1.500" SS188
2-7	5106006	1	NUT-HEX-NYLK, .375"-16 SS188
2-8	5106001	1	SPRING, EXTENSION 1.00" OD X 9.00" LG SS
3	5106250	1	HOSE, L EXP TANK, 18.5" LONG -(Connects to left expansion tank)
4	5106251	1	HOSE, R EXP TANK, 18" LONG -(Connects to right expansion tank)
5	5106336	1	TRANSAXLE, ZT3100, LH, ZL-GMPP-3B7B-1PXX
6	5106248	1	TRANSAXLE, ZT3100, RH, ZL-KMPP-3B7C-1PXX
7	5106656	2	FITTING, 08HB - 06MORB STRAIGHT
8	5106657	2	FITTING, 6410-04-06
9	5105992	9	NUT-HEX-NYLK, 0.3125"-18 SS188
10	5106550	4	SCR-CAP, HEX .3125"-18 X 2.750" SS188
11	5106056	4	SCR-CAP, HEX .3125"-18 X 2.250" SS188
12	5106009	8	WSHR-STL, FLT .343" X .750" X .050" SPC SS188
13	5106715	1	BELT, V, AK36 38.00 OC OHR, KVR CD
14	5106207	1	BLT-SLDR SH.375"X1.75".3125"-18 X.50" SS188
15	5106692	1	HYDRO RES. # 71328, 350 ml
16	5106214	2	SCR-CAP, HEX .250"-20 X .750" SS188
17	5106067	2	WSHR-STL, FLT .281" X .625" X .050" IS SS188
18	5106655	2	SNAP GRIP CLAMP .656 - .750 ID
19	5106683	2	CLAMP, MINIATURE WORM GEAR MAH6
20	5106040	2	NUT-HEX-NYLK, .250"-20 SS188
21	5105964	8	NUT-LUG, .500"-20 ZP
22	5106714	2	ASM, WHEEL & TIRE 20" X 10.00" - 12 LAWN BOSS
22-1	-----	1	RIM, Wheel
22-2	-----	1	TIRE, (ONLY)

Pump / Valve System Group

Note: Unless noted otherwise, use the standard torque specifications

Mfg. No: 5901755

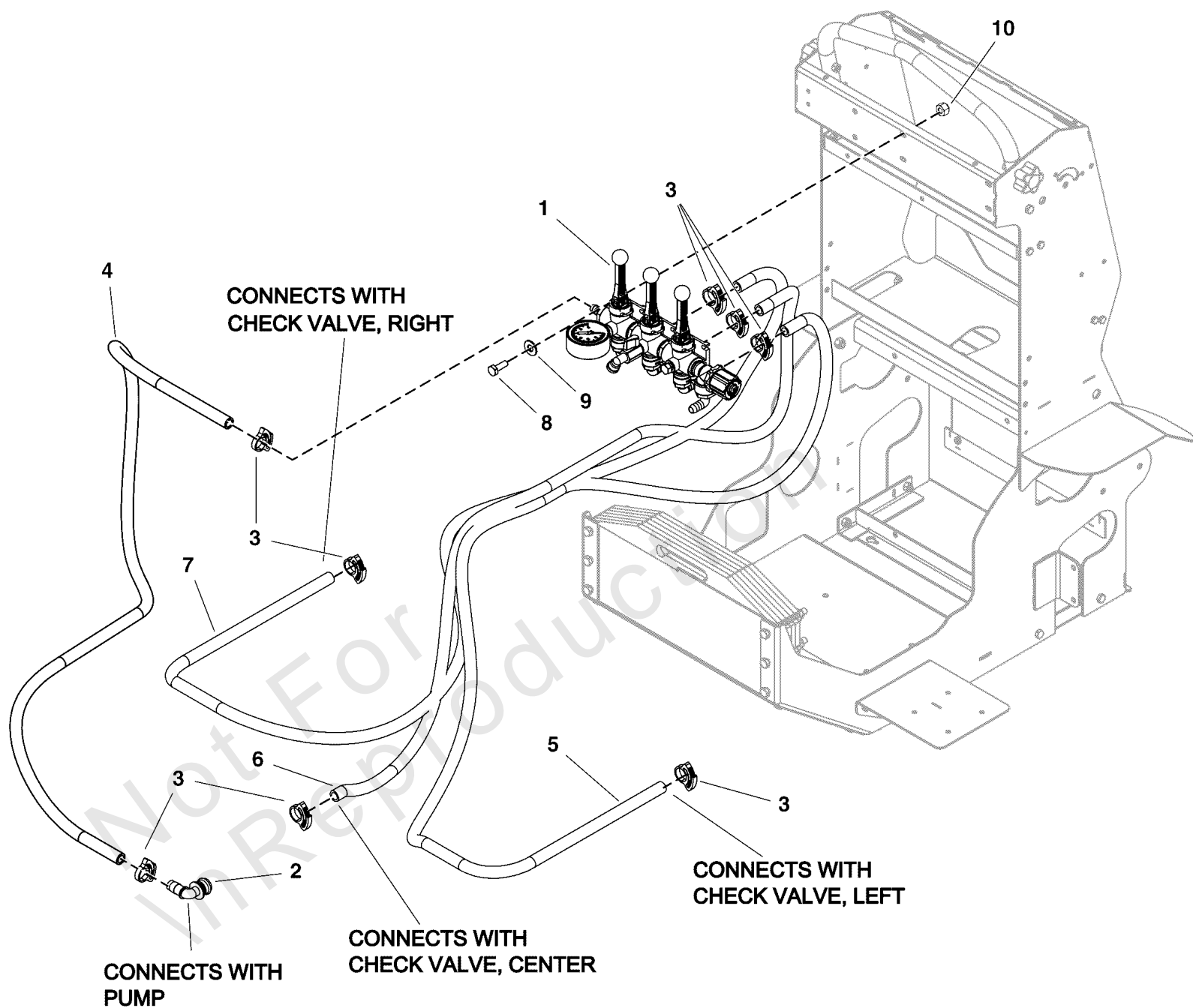

Pump / Valve System Group

REF NO	PART NO	QTY	DESCRIPTION
1	-----	1	REFER TO: SPRAY TOGGLE VALVE ASSEMBLY GROUP
2	5106675	1	FITTING, ELBOW, 3/4 QA - 1/2 BARB
3	5106655	8	SNAP GRIP CLAMP .656 - .750 ID
4	5418416	1	HOSE, VALVE INLET, 0.5" ID, 54" LONG
5	5418417	1	HOSE, LEFT BOOM, 0.5" ID, 86" LONG
6	5418418	1	HOSE, CENTER SPRAY, 0.5" ID, 61" LONG
7	5418419	1	HOSE, RIGHT BOOM, 0.5" ID, 84" LONG
8	5106214	4	SCR-CAP, HEX .250"-20 X .750" SS188
9	5106067	4	WSHR-STL, FLT .281" X .625" X .050" IS SS188
10	5106040	4	NUT-HEX-NYLK, .250"-20 SS188

Not For InReproduction

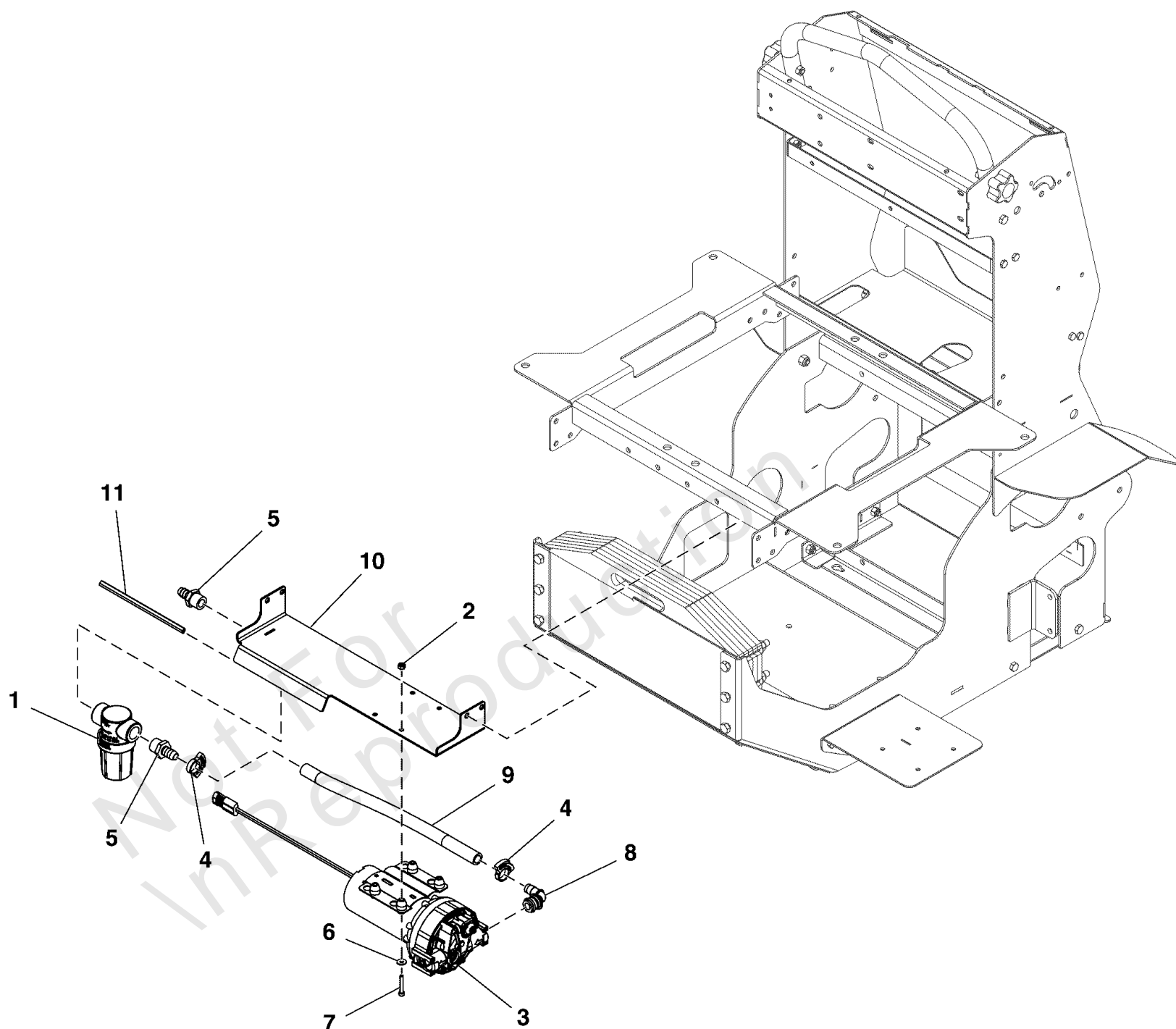

Pump Venture Group

REF NO	PART NO	QTY	DESCRIPTION
1	5105960	1	STRAINER, LIQUID, IN-LINE, 50 MESH
2	5105963	4	NUT-HEX-NYLK, #10-24 SS188
3	5106237	1	PUMP, VENTURE
4	5106655	2	SNAP GRIP CLAMP .656 - .750 ID
5	5106663	2	FITTING, 1/2 MPT - 1/2 BARB
6	5106673	4	WSHR-STL, FLT .203" X .562" X .040 IS SS188
7	5106674	4	SCR-CAP SH, #10-24 X 1.250" SS188
8	5106675	1	FITTING, ELBOW, 3/4 QA - 1/2 BARB
9	5418415	1	HOSE, PUMP SUCTION, 0.5" ID, 12" LONG
10	5418424	1	WELD, FILTER MOUNT BRACKET
11	5418427	1	TRIM FOR CONSOLE, 7 INCH

Not For InReproduction

Spray Bar Folding Boom Assembly Group

Note: Unless noted otherwise, use the standard torque specifications

Mfg. No: 5901755

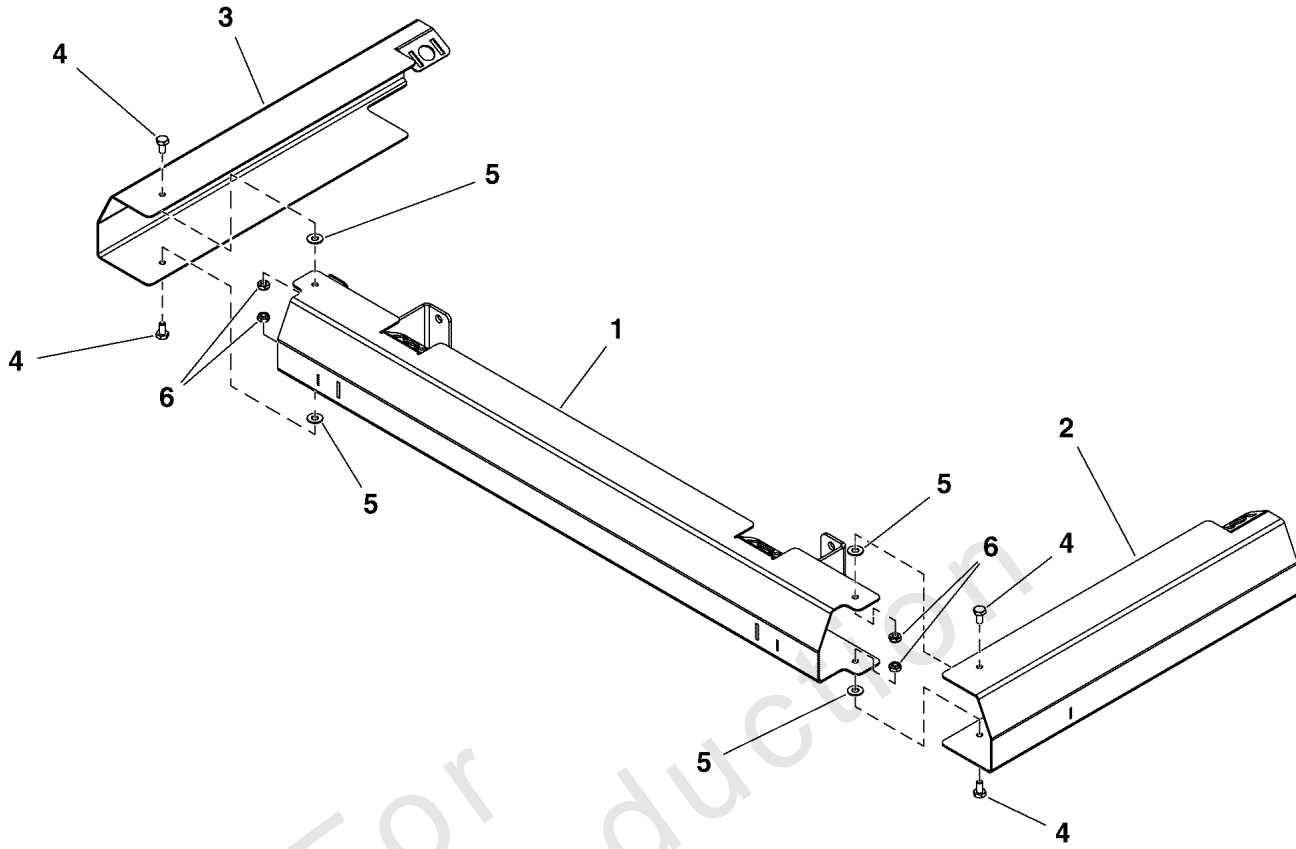

Not For
In Reproduction

Spray Bar Folding Boom Assembly Group

REF NO	PART NO	QTY	DESCRIPTION
1	5418394	1	WELD, CENTER, SPRAY BAR, FOLDING BOOMS
2	5418398	1	WELD, LEFT, SPRAY BAR, FOLDING BOOMS
3	5418400	1	WELD, RIGHT, SPRAY BAR, FOLDING BOOMS
4	5105893	4	SCR-CAP, HEX .250"-20 X .500" SS188
5	5106067	4	WSHR-STL, FLT .281" X .625" X .050" IS SS188
6	5105915	4	NUT-HEX-NYLK, .250"-20 TH SS188

Not For InReproduction

Spray Bar Group

Note: Unless noted otherwise, use the standard torque specifications

Mfg. No: 5901755

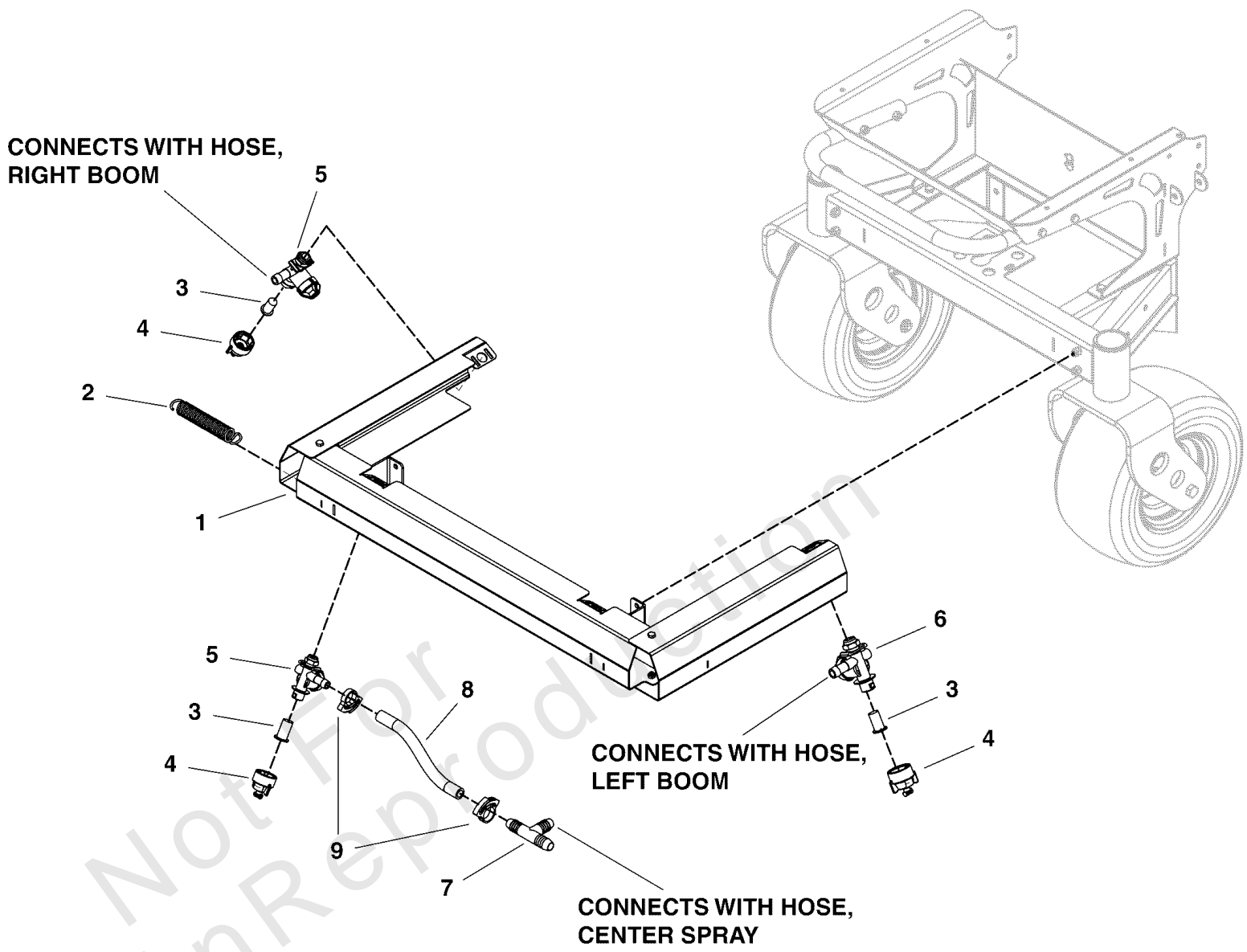

Spray Bar Group

REF NO	PART NO	QTY	DESCRIPTION
1	-----	1	Refer to: Spray Bar Folding Boom Assembly Group
2	5105972	2	SPRING, EXTENSION .64" OD X 4.00" LG SS
3	5105904	4	STRAINER, 50 MESH, POLYPROPYLENE TIP
4	5106034	4	NOZZLE, TIP, WIDE ANGLE, .03 ORIFICE
5	5106025	2	DIAPHRAGM CHECK VALVE, RIGHT
6	5106035	2	DIAPHRAGM CHECK VALVE, LEFT
7	5106713	1	FITTING, TEE, 1/2" MPT
8	5418420	2	HOSE, NOZZLE SUPPLY, 0.5" ID, 8.75" LONG
9	5106655	4	SNAP GRIP CLAMP .656 - .750 ID

Not For In Reproduction

Spray Tank Valve Group

Note: Unless noted otherwise, use the standard torque specifications

Mfg. No: 5901755

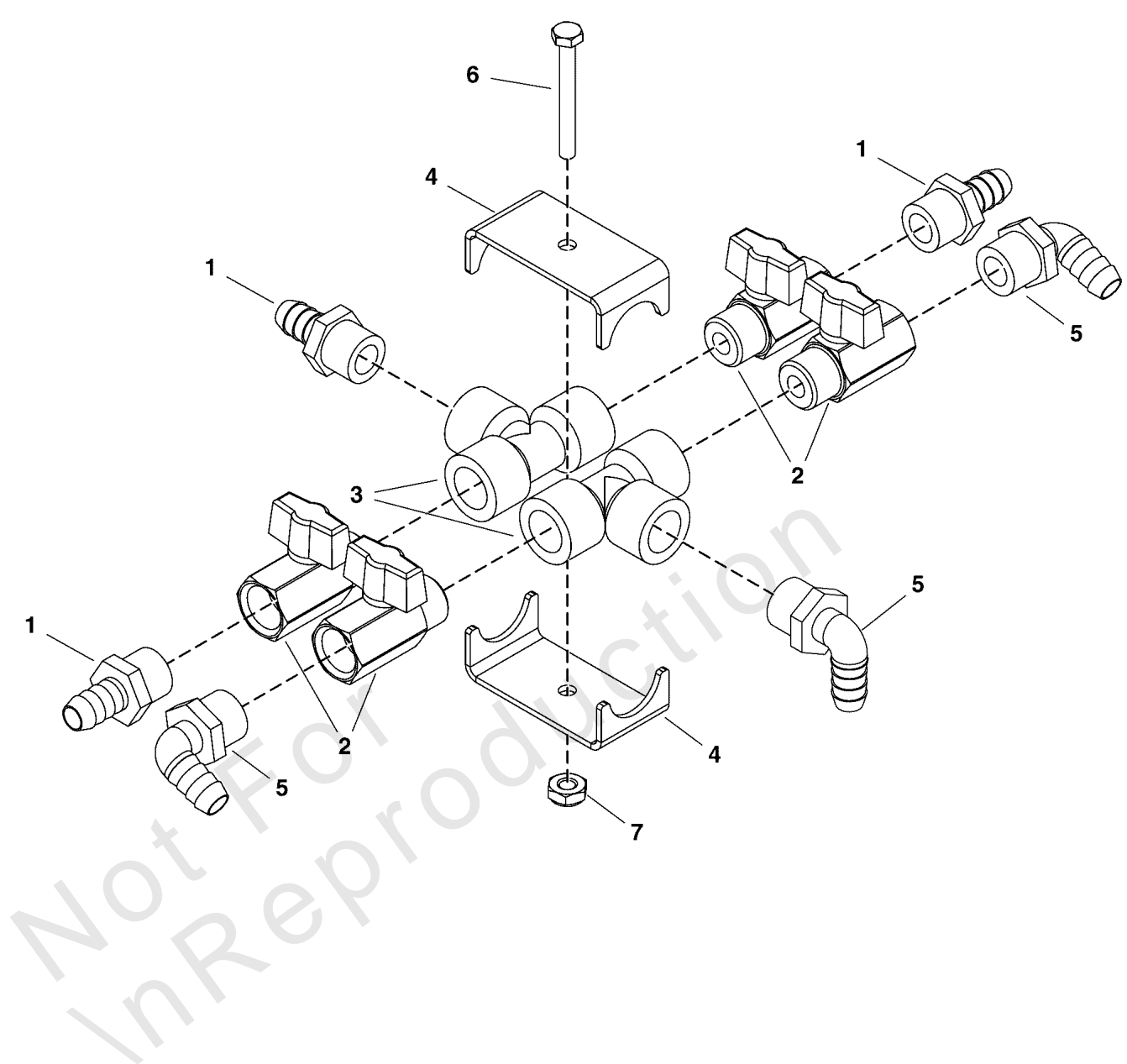

Not For
In Reproduction

Spray Tank Valve Group

REF NO	PART NO	QTY	DESCRIPTION
1	5106663	3	FITTING, 1/2 MPT - 1/2 BARB
2	5106003	4	VALVE, BALL, 1/2 MPT - 1/2 FPT
3	5106668	2	FITTING, TEE, 1/2" FPT
4	5418362	2	PLATE, TIE SPRAY FITTING
5	5106665	3	FITTING, 1/2 MPT - 1/2 BARB, 90 ELBOW
6	5106671	1	SCR-CAP, HEX .250"-20 X 2.250" SS188
7	5105915	1	NUT-HEX-NYLK, .250"-20 TH SS188

Not For In Reproduction

Spray Toggle Valve Group

Note: Unless noted otherwise, use the standard torque specifications

Mfg. No: 5901755

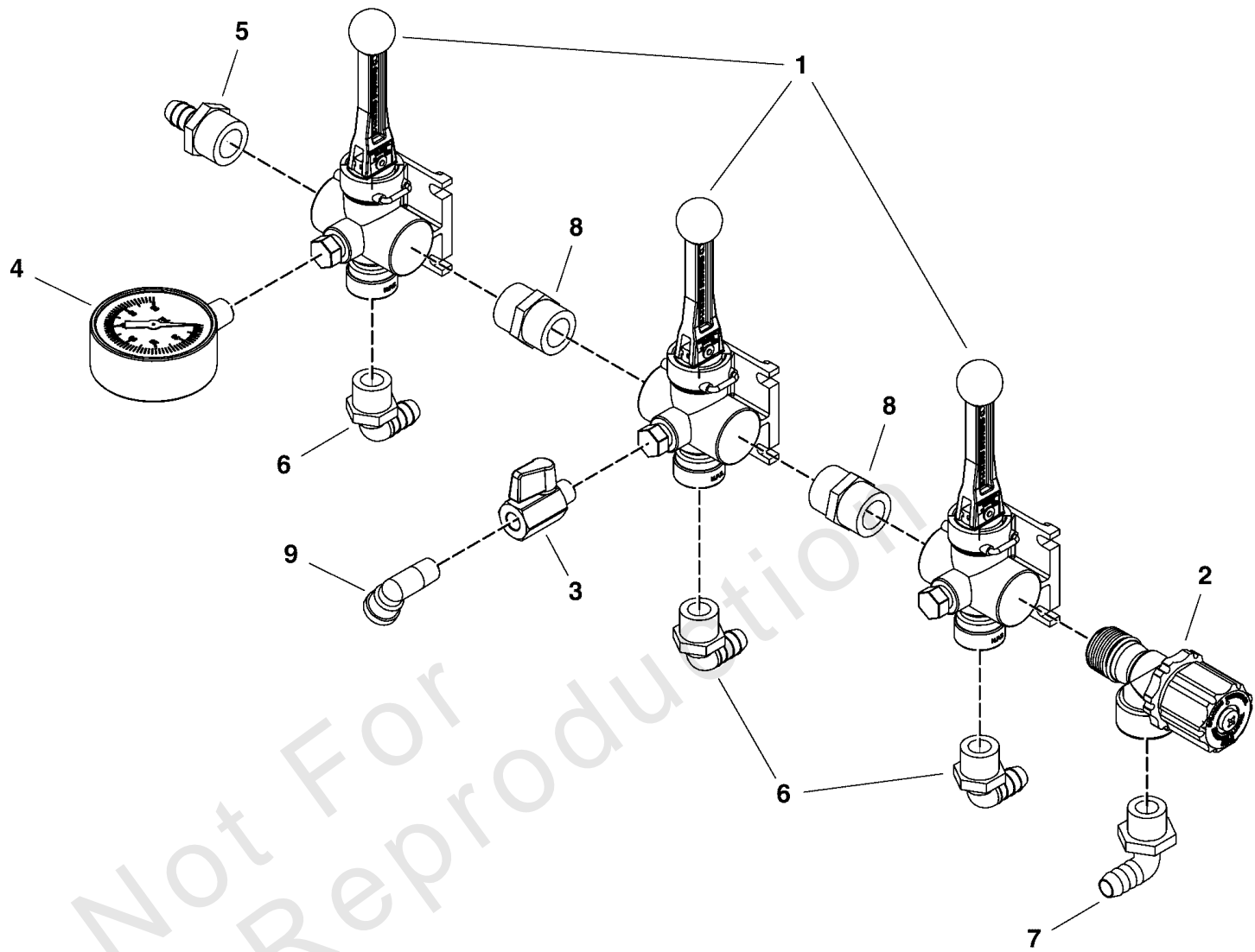

Spray Toggle Valve Group

REF NO	PART NO	QTY	DESCRIPTION
1	5106284	3	VALVE, DIRECTIONAL FLOW CONTROL, 12 GPM
2	5106149	1	VALVE, PRESSURE RELIEF, SPRAYING SYSTEM
3	5106265	1	VALVE, BALL, 1/4 MPT - 1/4 FPT
4	5106266	1	GAUGE, 0-60 PSI, 1/4 NPT, SS GLYC. FILLED
5	5106127	1	FITTING, 3/4 MPT - 1/2 BARB
6	5106665	3	FITTING, 1/2 MPT - 1/2 BARB, 90 ELBOW
7	5106667	1	FITTING, 3/4 MPT - 1/2 BARB, 90 ELBOW
8	5106666	2	NIPPLE, 3/4 MPT - 3/4 MPT
9	5106141	1	STREET ELBOW, 1/4 MPT-1/4 FPT, 90 DEG

Not For In Reproduction

Spray Wand Group

Note: Unless noted otherwise, use the standard torque specifications

Mfg. No: 5901755

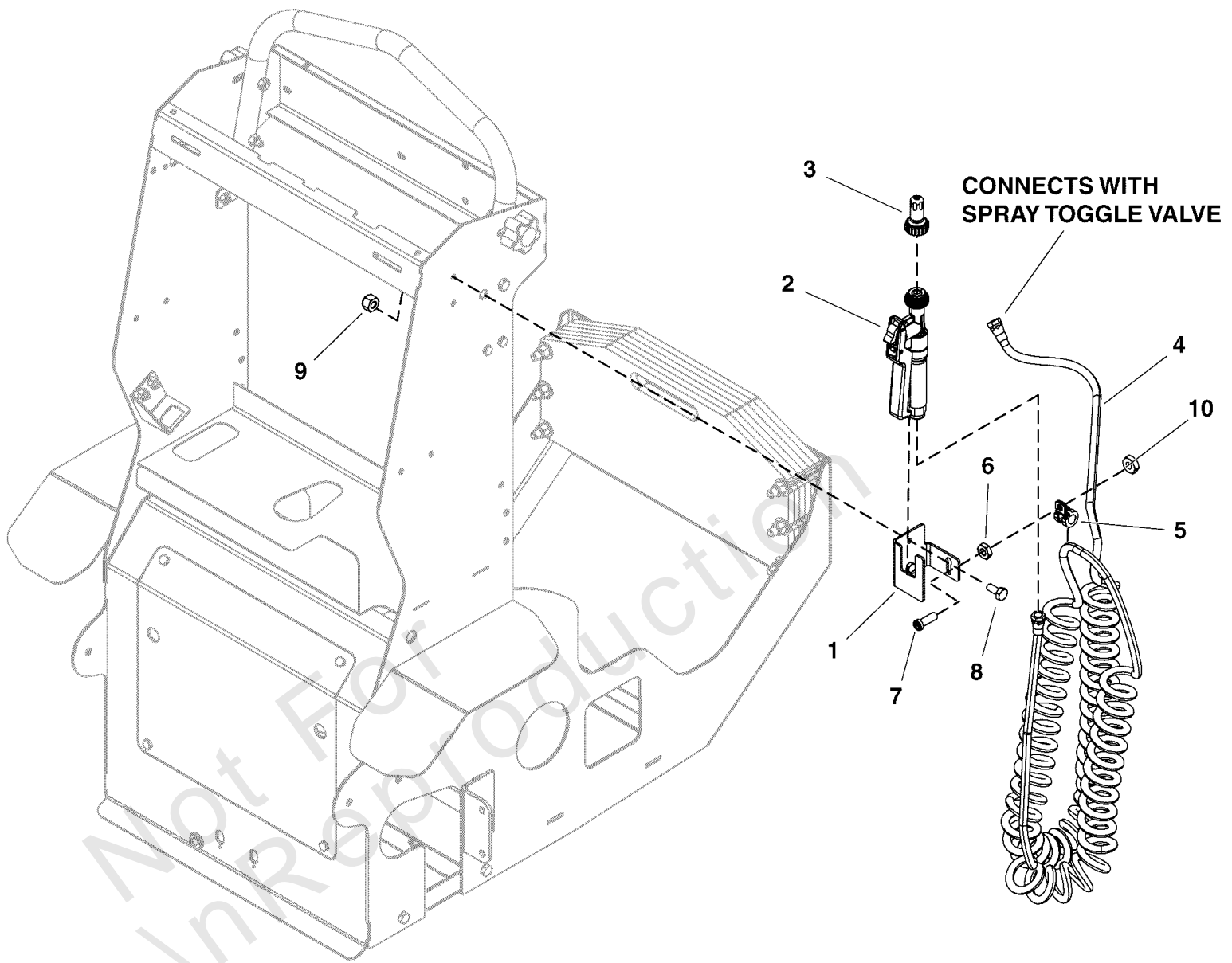

Spray Wand Group

REF NO	PART NO	QTY	DESCRIPTION
1	5106085	1	BRACKET, SPRAY WAND HOLDER
2	5105944	1	SPRAY GUN, 1/4 FPT
3	5106679	1	NOZZLE TIP, ADJUSTABLE SPRAY, STANDARD
4	5106055	1	HOSE, COIL 25 FT
5	5106054	1	CLAMP, SPRAY WAND LOOP
6	5105977	1	NUT-HEX, JAM .250"-20 SS188
7	5106125	1	SCR-CAP, SHLP .250-20 X .750" G8 ZP
8	5106029	2	SCR-CAP, HEX .250"-20 X .625" SS188
9	5106040	2	NUT-HEX-NYLK, .250"-20 SS188
10	5106016	1	NUT-HEX, JAM .250"-28 SS188

Not For In Reproduction

Sprayer Tank Group

Note: Unless noted otherwise, use the standard torque specifications

Mfg. No: 5901755

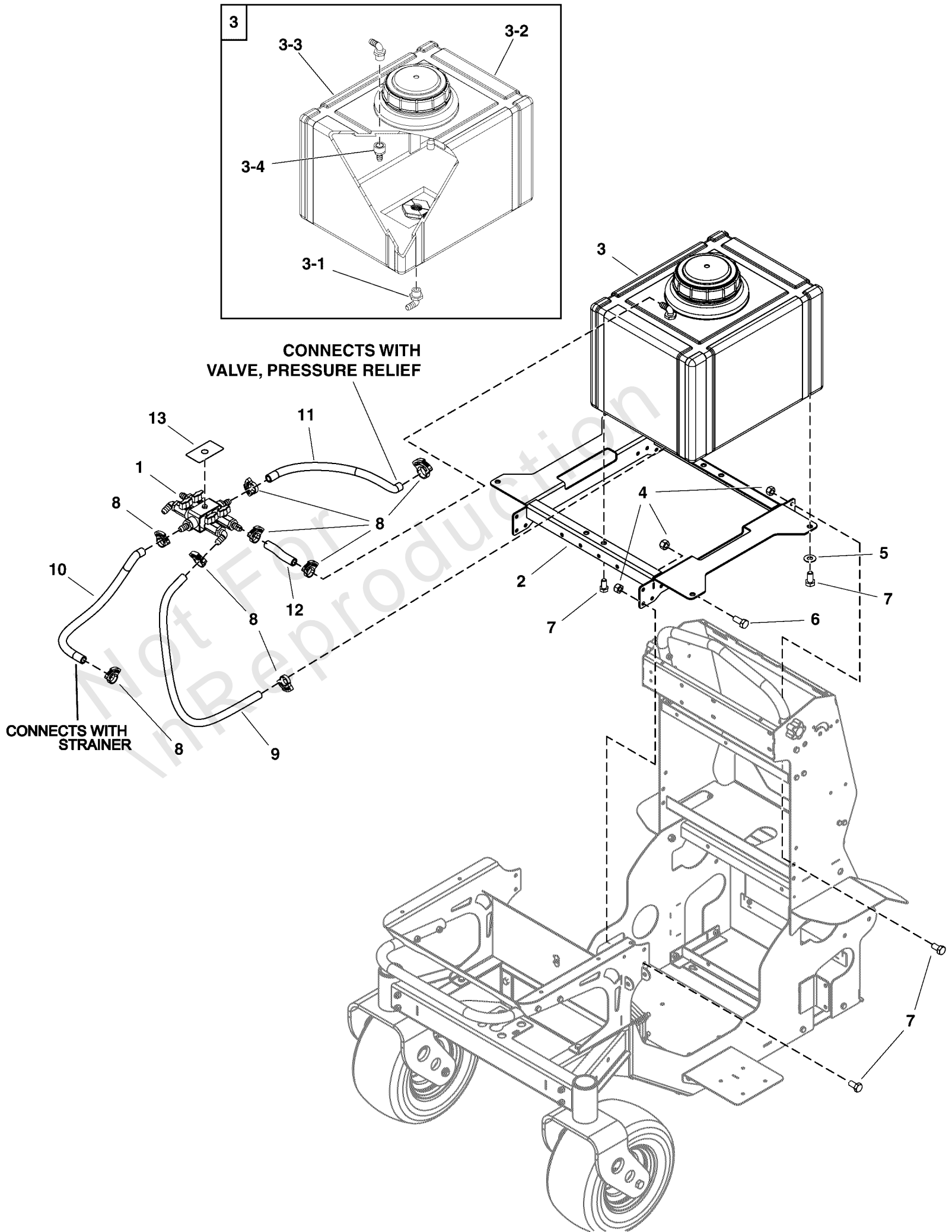

Sprayer Tank Group

REF NO	PART NO	QTY	DESCRIPTION
1	-----	1	Refer to: Spray Tank Valve Group
2	5418359	1	WELD, SPRAY TANK MOUNT
3	5418422	2	ASM, SPRAY TANK
3-1	5106667	1	FITTING, 3/4 MPT - 1/2 BARB, 90 ELBOW
3-2	5105949	1	TANK, 12 GAL RT W/SUMP HDPE NAT
3-3	5106665	1	FITTING, 1/2 MPT - 1/2 BARB, 90 ELBOW
3-4	5106672	1	FITTING, 1/2 FPT - 1/2 BARB
4	5105992	12	NUT-HEX-NYLK, 0.3125"-18 SS188
5	5106009	8	WSHR-STL, FLT .343" X .750" X .050" SPC SS188
6	5106024	4	SCR-CAP, HEX .3125"-18 X .750" SS188
7	5106649	16	SCR-CAP, HEX .3125"-18 X .625" SS188
8	5106655	12	SNAP GRIP CLAMP .656 - .750 ID
9	5418411	2	HOSE, TANK SUPPLY, 0.5" ID, 28" LONG
10	5418413	1	HOSE, FILTER SUPPLY, 0.5" ID, 25" LONG
11	5418414	1	HOSE, MANIFOLD SUPPLY, 0.5" ID, 14" LONG
12	5418423	2	HOSE, TANK RETURN, 0.5" ID, 2" LONG
13	5106710	1	DECAL, SPRAY TANK SUCTION / RETURN LABEL

Spreader Shield Group

Note: Unless noted otherwise, use the standard torque specifications

Mfg. No: 5901755

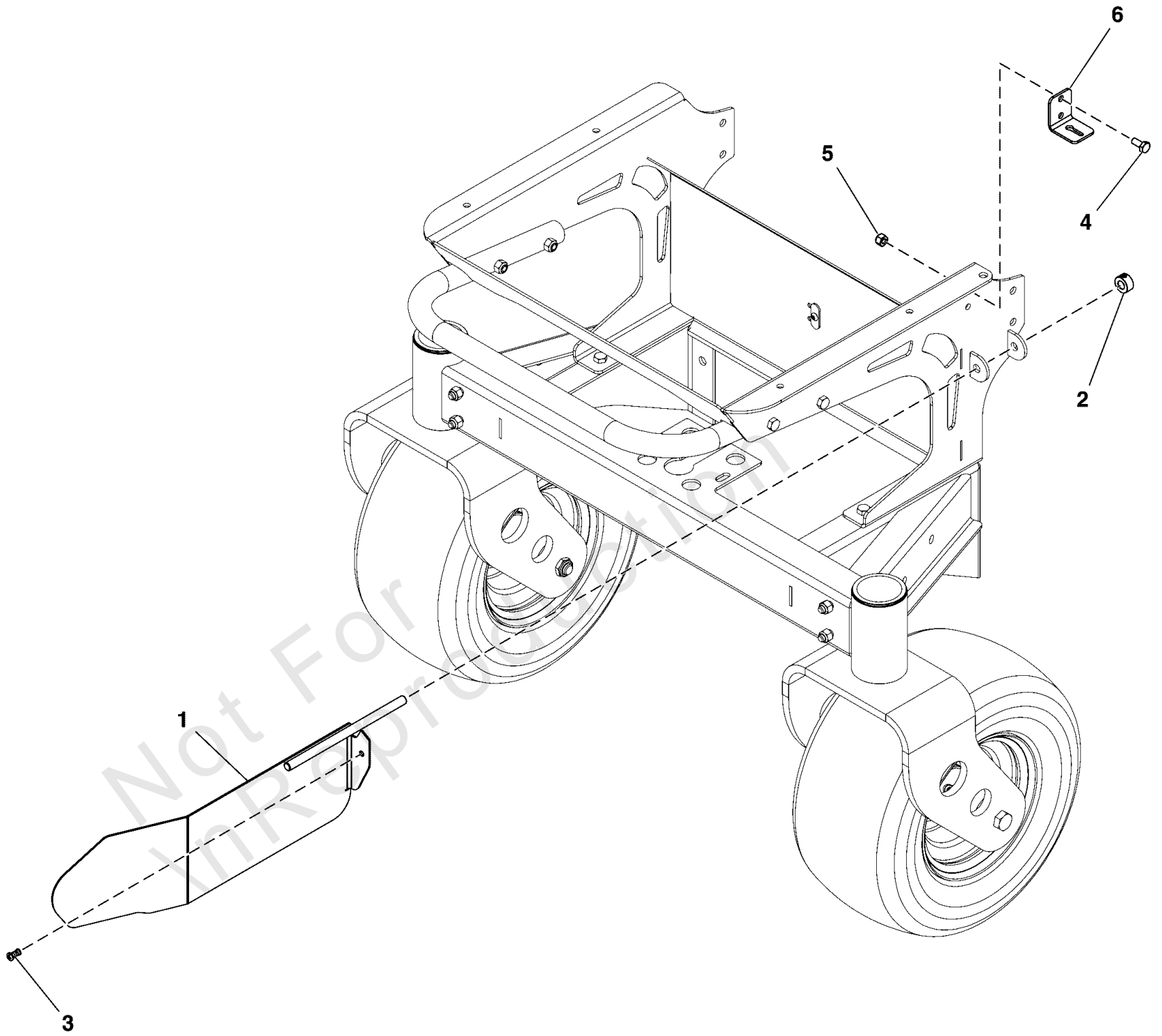

Spreader Shield Group

REF NO	PART NO	QTY	DESCRIPTION
1	5418403	1	WELD, DIVERTER SHIELD
2	5106023	1	COLLAR, SHAFT .375ID X .750OD X .375WD
3	5105921	1	FITTING, SWIVEL ACCUWAY
4	5106029	2	SCR-CAP, HEX .250"-20 X .625" SS188
5	5106040	2	NUT-HEX-NYLK, .250"-20 SS188
6	5418405	1	BRACKET, L-SHAPE DIVERTER CABLE

Not For InReproduction

Thigh Pad Group

Note: Unless noted otherwise, use the standard torque specifications

Mfg. No: 5901755

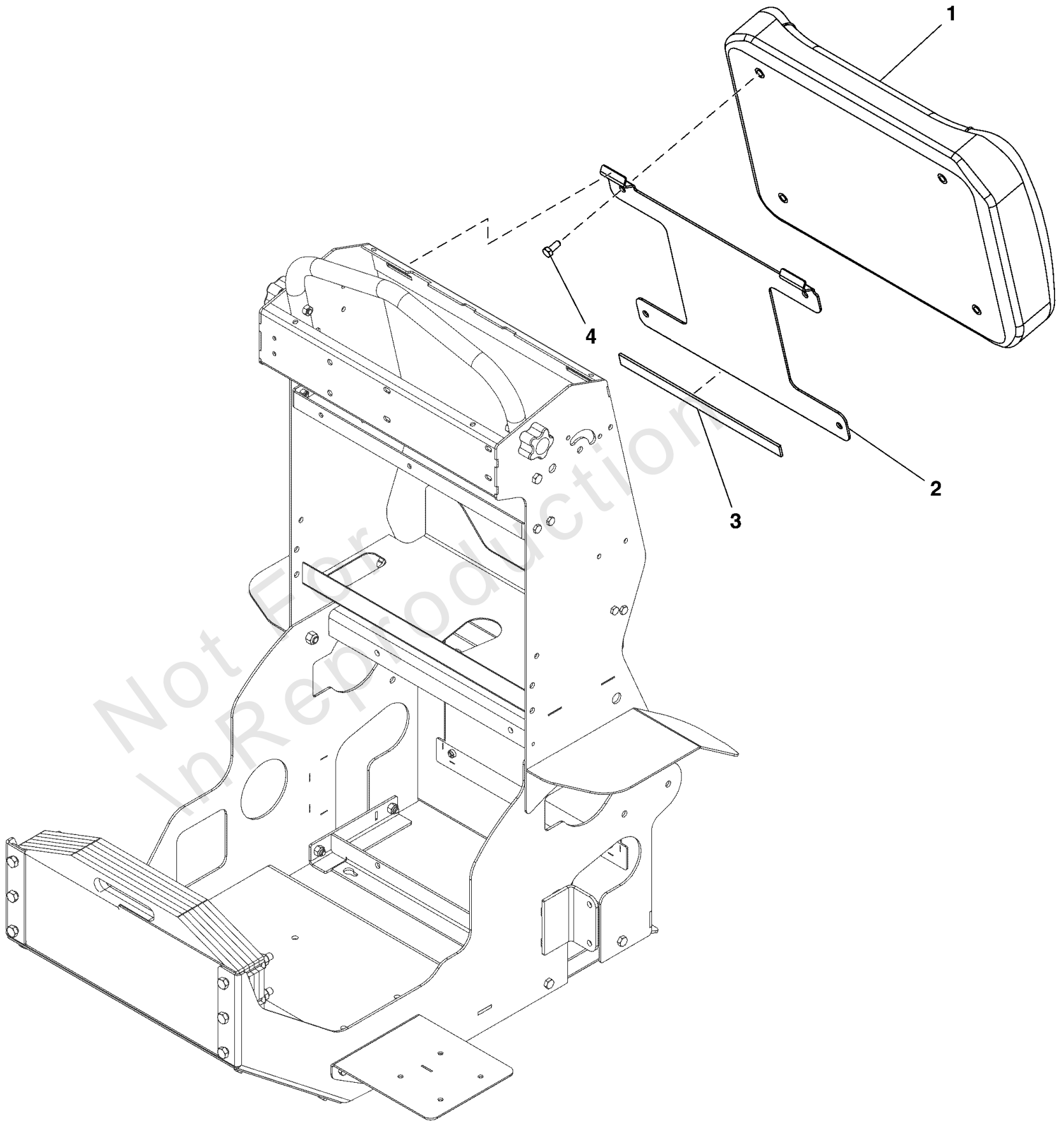

Thigh Pad Group

REF NO	PART NO	QTY	DESCRIPTION
1	5418406	1	PAD, THIGH VENTURE
2	5418407	1	PLATE, MOUNT THIGH PAD
3	5418421	1	HOOK AND LOOP, 0.750" X 12.00"
4	5106024	4	SCR-CAP, HEX .3125"-18 X .750" SS188

Not For InReproduction

Hardware Identification & Torque Specifications

Torque Specification Chart								
FOR STANDARD METRIC MACHINE HARDWARE (Tolerance ± 20%)								
Property Class	5.6		8.8		10.9		12.9	
	Class 5.6		Class 8.8		Class 10.9		Class 12.9	
Size Of Hardware	in/lbs	Nm.	in/lbs	Nm.	in/lbs	Nm.	in/lbs	Nm.
	ft/lbs		ft/lbs		ft/lbs		ft/lbs	
M3	5.88	.56	13.44	1.28	19.2	1.80	22.92	2.15
M4	13.44	1.28	30.72	2.90	43.44	4.10	52.56	4.95
M5	26.4	2.50	60.96	5.75	5.97	8.10	7.15	9.7
M6	44.64	4.3	7.3	9.9	10.3	14	12.1	16.5
M7	5.2	7.1	12.1	16.5	16.9	23	19.9	27
M8	7.7	10.5	17.7	24	25	34	29	40
M10	15	21	35	48	50	67	59	81
M12	26	36	61	83	86.2	117	103	140
M14	42	58	101	132	136	185	162	220
M16	64	88	147	200	210	285	250	340
M18	89	121	202	275	287	390	346	470
M20	126	171	290	390	405	550	486	660
M22	169	230	390	530	559	745	656	890
M24	217	295	497	375	708	960	840	1140
M27	320	435	733	995	1032	1400	1239	1680
M30	435	590	995	1350	1401	1900	1681	2280
M33	590	800	1349	1830	1902	2580	2278	3090
M36	759	1030	1740	2360	2441	3310	2935	3980
M39	988	1340	2249	3050	3163	4290	3798	5150

Torque Specification Chart						
FOR STANDARD MACHINE HARDWARE (Tolerance ± 20%)						
Hardware Grade	No Marks		SAE Grade 5		SAE Grade 8	
	SAE Grade 2		SAE Grade 5		SAE Grade 8	
Size Of Hardware	in/lbs	Nm.	in/lbs	Nm.	in/lbs	Nm.
	ft/lbs		ft/lbs		ft/lbs	
8-32	19	2.1	30	3.4	41	4.6
8-36	20	2.3	31	3.5	43	4.9
10-24	27	3.1	43	4.9	60	6.8
10-32	31	3.5	49	5.5	68	7.7
1/4-20	66	7.6	8	10.9	12	16.3
1/4-28	76	8.6	10	13.6	14	19.0
5/16-18	11	15.0	17	23.1	25	34.0
5/16-24	12	16.3	19	25.8	29	34.0
3/8-16	20	27.2	30	40.8	45	61.2
3/8-24	23	31.3	35	47.6	50	68.0
7/16-14	30	40.8	50	68.0	70	95.2
7/16-20	35	47.6	55	74.8	80	108.8
1/2-13	50	68.0	75	102.0	110	149.6
1/2-20	55	74.8	90	122.4	120	163.2
9/16-12	65	88.4	110	149.6	150	204.0
9/16-18	75	102.0	120	163.2	170	231.2
5/8-11	90	122.4	150	204.0	220	299.2
5/8-18	100	136	180	244.8	240	326.4
3/4-10	160	217.6	260	353.6	386	525.0
3/4-16	180	244.8	300	408.0	420	571.2
7/8-9	140	190.4	400	544.0	600	816.0
7/8-14	155	210.8	440	598.4	660	897.6
1-8	220	299.2	580	788.8	900	1,244.0
1-12	240	326.4	640	870.4	1,000	1,360.0

The guides and ruler furnished below are designed to help you select the appropriate hardware.



Nut, M8

Thread Diameter (mm)

Inside Diameter (in) Threads per inch

Nut, 1/2-16



Screw, M8- 1.25 x 25

Thread Diameter (mm) Distance between threads (mm) Body Length (mm)

Body Diameter Threads per inch Body Length (in)

Screw, 1/2- 16 x 2



Standard Hardware Sizing

When a washer or nut is identified as 1/2" (M8), this is the *Nominal size*, meaning the *inside diameter* is 1/2 inch (8mm metric thread diameter); if a second number is present it represents the *threads per inch* (distance between threads).

When bolt or capscrew is identified as 1/2 - 16 x 2" (M8 - 1.25 x 50), this means the *Nominal size*, or body diameter is 1/2 inch (8mm metric thread diameter), the second number, 16, represents the *threads per inch*, (*distance between threads*). The final number is the body length of the bolt or screw, 2 inches (50mm).

NOTES

- These torque values are to be used for all hardware excluding: locknuts, self-tapping screws, thread forming screws, sheet metal screws and socket head setscrews.
- Recommended seating torque values for locknuts:
 - for prevailing torque locknuts - use 65% of grade 5 torques.
 - for flange whizlock nuts and screws - use 135% of grade 5 torques.
- Unless otherwise noted on assembly drawings, all torque values must meet this specification.

Common Hardware Types

Hex Head Capscrew



Washer



Carriage Bolt



Hex Nut

Wrench & Fastener Size Guide

1/4" Bolt or Nut Wrench—7/16"	5/16" Bolt or Nut Wrench—1/2"	3/8" Bolt or Nut Wrench—9/16"	7/16" Bolt or Nut Wrench (Bolt)—5/8" Wrench (Nut)—11/16"	1/2" Bolt or Nut Wrench—3/4"
M6 Bolt or Nut Wrench—10mm	M8 Bolt or Nut Wrench—13mm	M10 Bolt or Nut Wrench—17mm	M12 Bolt or Nut Wrench—19mm	M14 Bolt or Nut Wrench—22mm

