

X-Factor

The Hustler SL>X Range



1 HUSTLER[®]

SL>X

FIVE REASONS TO CHOOSE A SL BALEFEEDER

- 01: Easy to use.** Single level feed control make it very easy to use and ideal for share milkers.
- 02: Toughest chain on the market.** Super strong 12,000 lb roller chain, with tough 40mm x 40mm zinc-plated bars. Bars are bolted to the chain, a stronger and more easily replaceable system.
- 03: Tough polyethylene floor.** Non corrosive, impervious to UV, slippery, easily repairable and very shock resistant. Fully enclosed - no wastage of expensive feed. Long bed can take 5' long bales.
- 04: Low maintenance.** Instead of bushes we use longer lasting block bearings, mounted outboard to keep them clean and free of damage.
- 05: Best bale security on the market.** The high rear bar means the bale cannot screw off the back on hills. Optional side rails are available.

"I jumped at the chance to test the new SL700X. Not only have Hustler made it lower for far better stability, they've also managed to give it impressive ground clearance. It's the best feeder I've ever used." **HAWKE'S BAY DAIRY FARMER**

Action Station

THE SL>X FEED UNIT

2
YEAR
WARRANTY

LOW MAINTENANCE BEARINGS

The SL700X is equipped with our proven, greasable, self-aligning bearings with trash shields that will easily outlast any type of bush system.

Removable bearing covers protect the bearings from mud and make cleaning and greasing easy.

BALE CHAMBER

Even the stickiest bales are not a problem for our new bale chamber. It is steeper and deeper for feeding out a bigger variety of bales and preventing rollout on steep terrain.

Increased front and rear bale chamber enclosure reduces feed falling out, and a high security bar holds the bale securely in the chamber.

12,000 LB CHAINS

Zinc-plated 12,000 lb chains with heavy duty rollers and pins make our chain drive system almost twice as strong as our competitors, now incorporating a chain tensioner.

The greater wear surface on each roller increases chain life because they can't stretch or snake. Fully enclosed chain and sprocket guides eliminate derailment.

40 X40 RHS FEED BARS

Built to withstand extreme vertical, horizontal and torsional loads, these are the strongest feed bars on the market.

They are zinc plated for corrosion resistance and bolted (rather than welded) to make them stronger and easier to replace if necessary.

DRIVE SYSTEM

A beefed up drive system, including a newly designed coupling, provides unparalleled direct drive strength.

A bigger, 400cc motor allows you to feed even the heaviest and slopiest bales with ease.

TEETH

Our unique, extra strong 6mm shark teeth are designed to prevent feed falling under the tyre by releasing it at precisely the right moment.

Teeth can be angled for more aggression, or the whole bar can be unbolted or removed without breaking the chain or using a grinder.

DUAL SIDE FEED

A single lever control enables the SL700X to feed bales out to the left or right and gives precise control of the rate of feed.

FLOOR

A fully enclosed floor design eliminates wastage by preventing feed from falling out. Made from solid, 5mm polyethylene sheeting, it is UV and shock resistant, and will not corrode.

Its extra slipperiness reduces the amount of torque needed and makes it easier to turn bales that would otherwise grip to a steel surface.

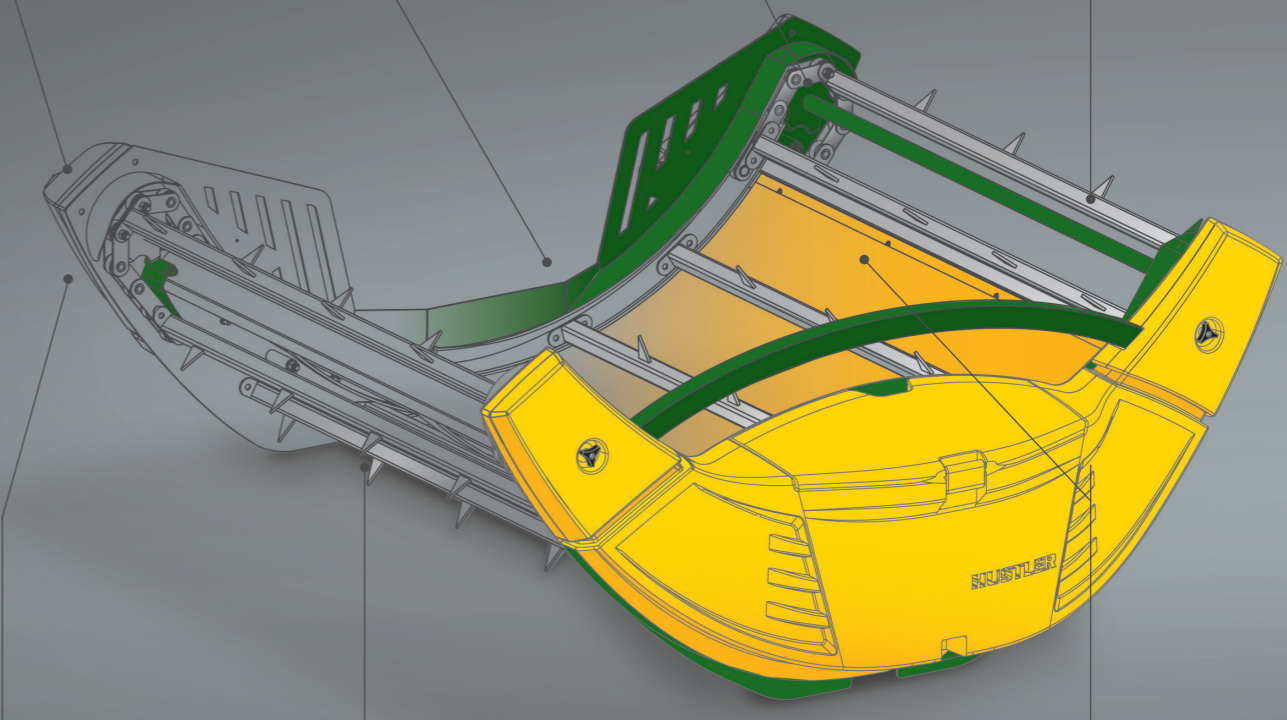

Hustler SL350

SINGLE BALE FEEDER

This is a 3-point-linkage single bale feeder suitable for all types of round bales. It is the lightest unit on the market, ideal for smaller farms and smaller tractors, while still having the capability to handle the biggest of bales and fastest of tractors.



High-mounted hook latch with new rope guide for easy disconnection.

Ultra low cradle for loading.

Protected outboard mounted double sealed heavy-duty 4-bolt bearings.

Fully enclosed non-corroding floor to eliminate feed waste.

High back bar to restrain bale.

Hustler SL450X

SINGLE BALE TROUGH FEEDER

With a fully adjustable hydraulic extension, the SL450X is ideal for feeding over fences and into troughs. The extension raises for transport, making the unit narrow enough to easily fit through gateways and comply with road width regulations.



Dual latch system for superior rigidity.

Protected outboard mounted double sealed heavy-duty 4-bolt bearings.

Wide skids for stability.

Fully enclosed front and back to eliminate feed waste.

High sides and fully enclosed floor at any angle prevent feed spillage.

Large extension for maximum reach.

SL350X AND SL450X LOADING SEQUENCE



01 Disengage cradle



02 Back in to pick up bale



03 Load bale onto cradle



04 Pause to remove net wrap



05 Pick up cradle with tynes



06 Ready to feed

2
YEAR
WARRANTY

Hustler SL700X

TRAILED TWO BALE FEEDER

Designed for medium to large operations feeding out thousands of bales each year, the SL700X is built extremely tough to go the distance.

2
YEAR
WARRANTY

BEARING COVERS

Removable bearing covers protect the bearings from mud and make cleaning and greasing easy.

OPTIONAL STRINGBOX

Our massive new stringbox keeps your wrap and string out of harms way and your tractor cab clean and smell-free. Big enough to hold fencing standards, knives and anything else you need on the job.

OPTIONAL SIDEBARS

Adding a set of sidebars quickly transforms the SLX to a capable square and round bale feeder.



OPTIONAL WHEELS

Optional 10/75-R15.3 traction tyres and 13/55-R17 flotation tyres are available.

OPTIONAL MUDGUARDS

For keeping the feed clean and dry in-transit.

WEIGHT

Impressive strength to weight ratio has been achieved by constructing the SL700X from high tensile steel, which is 50% stronger than mild steel. At just 785kgs, it can be towed easily by smaller tractors.

Bolted construction eliminates stress cracking common with some conventional bale feeders.

CHASSIS DESIGN

Our fully enclosed chasis prevents rust by stopping water getting in. We've built the SL700X with plenty of ground clearance to minimise bellying out. To avoid damage to chains and feed bars when it does touch the ground, we've made the underside of the chasis smooth, so it slides until the wheels gain traction again.

GUARD PLATE

We've incorporated a guard plate underneath the SL700X, so there's nothing to tear or catch as you drive over electric fences and other obstacles.

DRAWBAR

Our single post drawbar design has set the benchmark in feeder manoeuvrability. Now it is completely removable, which means you can replace it without having to buy a whole new chasis. By lowering the drawbar, we've made it easier (and less painful) stepping from side to side.

TOWING EYE

The 12,000kg towing eye now has an easy-to-use height adjustment, enabling the SL700X to stay level behind virtually any tractor. Its ability to rotate 360° makes feeding out on steep terrain trouble-free.

SL700X
LOADING
SEQUENCE

Handle it

TOTAL CONTROL LOADING SERIES 2



01 Back tynes into bale

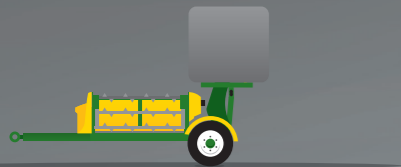

02 Bale is always under control



03 Remove net wrap



04 Tynes withdraw



05 Tynes ready to pick up 2nd bale



06 Bales in transport position

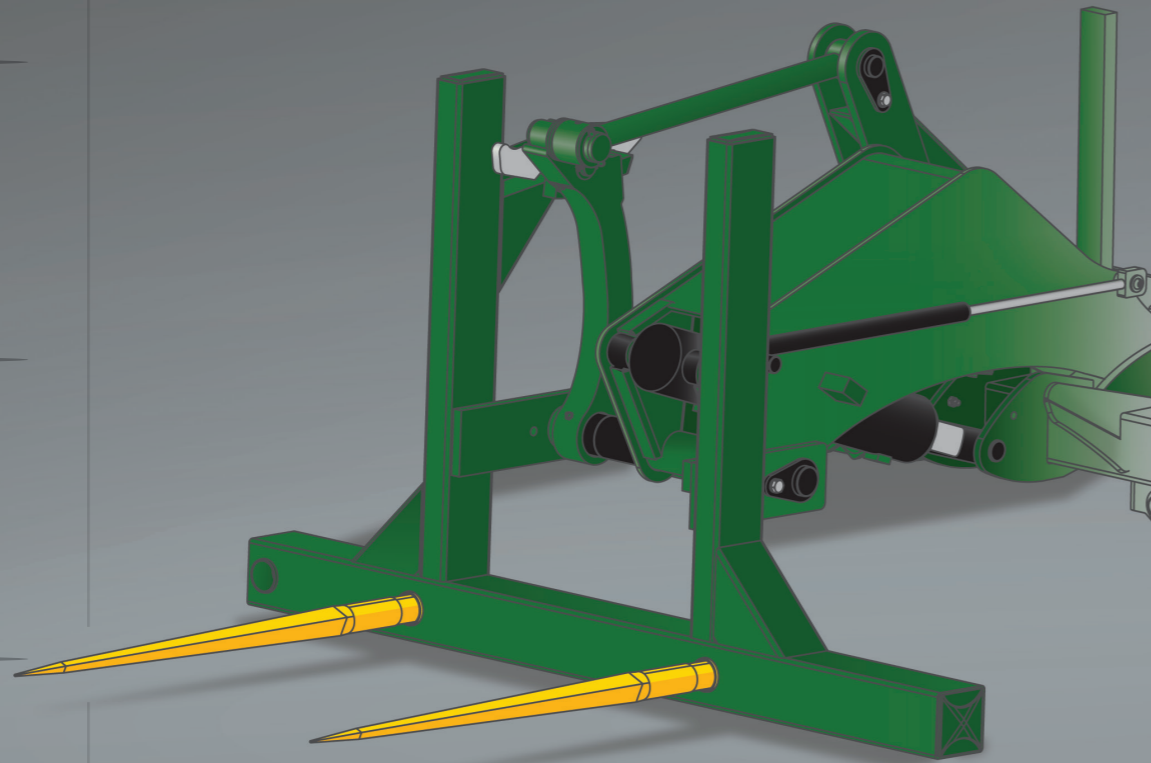

Faster cycle times, quieter operation, bigger bale handling capacity and a foolproof resetting operation are just some of the refinements we've made to Hustler's unique Total Control Loading (TCL) system that has revolutionized bale handling since it was introduced eight years ago.

With just one hydraulic cylinder to complete the entire loading operation, and a new gas strut to help reset the loader, the TCL Series 2 is the fastest loading system out there. And with only one ram to fill with oil, it's also less demanding on your tractor's hydraulics.

Our Total Control Loading System provides exactly what it says: total control. Unlike other systems, the operator can reverse the bale if necessary, even once the bale is positioned low over the cradle for unwrapping.

THE TOTAL CONTROL LOADING ADVANTAGE:

- Easy bale pickup means no digging up of paddocks or dirt mixing with feed
- Gentle and accurate placement of the bale in the bale chamber
- Easy to line up the bale
- Minimal feed wastage because the net wrap can be removed above the bale chamber
- Bale is secure during transport, even on steep inclines
- Handles round and square bales
- Second bale can be positioned low to the ground for added ballast.



HILL COUNTRY STABILITY

A lower centre of gravity and steeper feed cradle result in a 20% increase in stability. This means greater safety and peace of mind when the going gets steep.



SWIVELLING TOWING EYE

Our heavy-duty 360 degree towing eye handles the roughest terrain without causing damage to your machine.

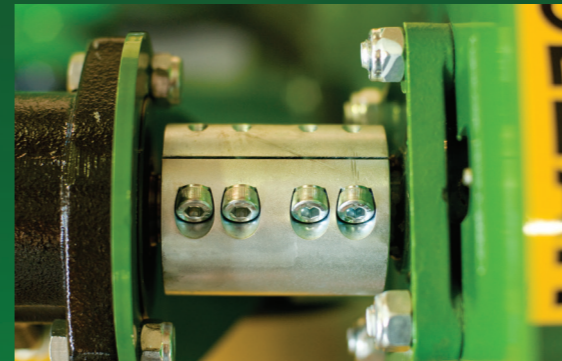

NEW DRIVE

A beefed up drive system, including a newly designed coupling, provides unparalleled direct drive strength, while a bigger, motor allows you to feed even the heaviest and sloppiest bales with ease.

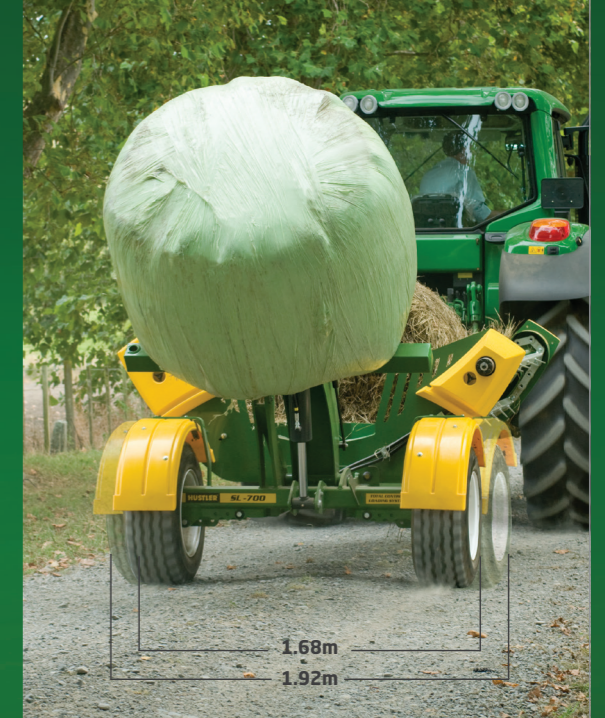

ADJUSTABLE WHEEL TRACK

Choose between the 3 axle width options (1.4m -1.6m) to suit your individual application.



MASSIVE AXLE

You need to feed out in all conditions, so we've fitted the strongest stub axle on the market. The SL700X is suited to the fastest tractors available today.



HUSTLER INNOVATION

Hustler has been building strong, reliable balefeeders for New Zealand for more than 20 years.

At Hustler, we develop our equipment based on input from the people who use our machines. It's our practical innovations and our ability to meet changing demands that gives Hustler the edge.

Our commitment to research and development means we build equipment you can consistently rely on, year in year out, ensuring you exceptional value for money.

Hustler technology: We have adopted LEAN manufacturing techniques, robotic welding, laser and plasma cutting technology and CNC-controlled equipment to ensure the very best quality, consistency and efficiency.

The introduction of sandblasting equipment and a wet-sprayed, 2-coat system mean your Hustler product has the best possible finish.

Hustler heritage: When you invest in Hustler products you are investing in forty years of research and development, backed up by Hustler's extensive nationwide network of accredited dealers.



Our dealer network guarantees technical backup and quick replacement of parts.

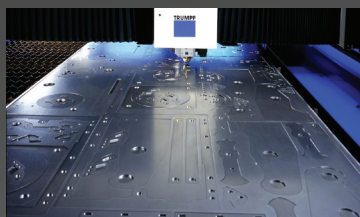

CHAINLESS 8000 TRAILED 4-BALE FEEDER



CHAINLESS 4000 TRAILED 2-BALE FEEDER



CHAINLESS 2000 LINKAGE FEEDER



SL700X TRAILED 2-BALE FEEDER



SL350 LINKAGE FEEDER



SL450X LINKAGE TROUGH FEEDER



NORTHERN 07 847 6923
CENTRAL 06 873 9154
SOUTHERN 03 434 0412

www.hustlerequipment.co.nz

