

FR SERIES FORAGE CRUISER

FR480 | FR550 | FR650 | FR780 | FR920



The FR is a game changer.

New Holland has been at the forefront of the forage harvesting sector for over half a century with a whole host of pioneering industry firsts that have revolutionized the way you harvest today. The five-model FR Forage Cruiser line continues that legacy, with powers ranging from 476 horsepower up to the mighty 911 horsepower of the flagship FR920. New Holland married outstanding chopping performance with unmatched operator comfort and added superior control with the IntelliView™ IV monitor. Significantly improved capacity and productivity result from better crop flow and reliable engines. All this is wrapped up in a sleek, tapered design which has New Holland written all over it.

Ultimate capacity

New Holland knows that throughput is king where forage harvesters are concerned and that owners dream in tons per hour. The FR920 is powered by the V20 8-cylinder V-layout engine developed by FPT Industrial. This mighty beast will have you steaming up and down fields. ECO engine management mode works to ensure the engine is always fully loaded in relation to a preset engine speed to deliver optimal operating efficiency and performance. Renowned Power Cruise™ features ensure your FR's voracious appetite is satisfied in fields of varying crop density, and state-of-the-art headers eat grass, corn and whole biomass crop.

Superior harvest quality

The industry's widest crop channel from feedrolls to spout flipper means a thin, controlled crop mat for best-in-class chop quality. HydroLoc™ feedroll drive technology guarantees constant chop length independent of throughput and crop type. When combined with uniform kernel cracking from the most efficient crop processor around, you've got the ingredients for chopping the highest quality cattle feed.

Best-in-class fuel efficiency

The FR650 Forage Cruiser was put through its paces by the DLG Test Center for Technology and Farm Inputs in Gross-Umstadt, Germany. The results will offer you impressive efficiency savings. The FR650 consumed a mere 0.0349 gallons of diesel per ton of corn harvested when chopping at .75 inches (19 mm). When compared to the previous FR600, this translates to 13% fuel saving, while increasing capacity by 14%, saving you both time and money.



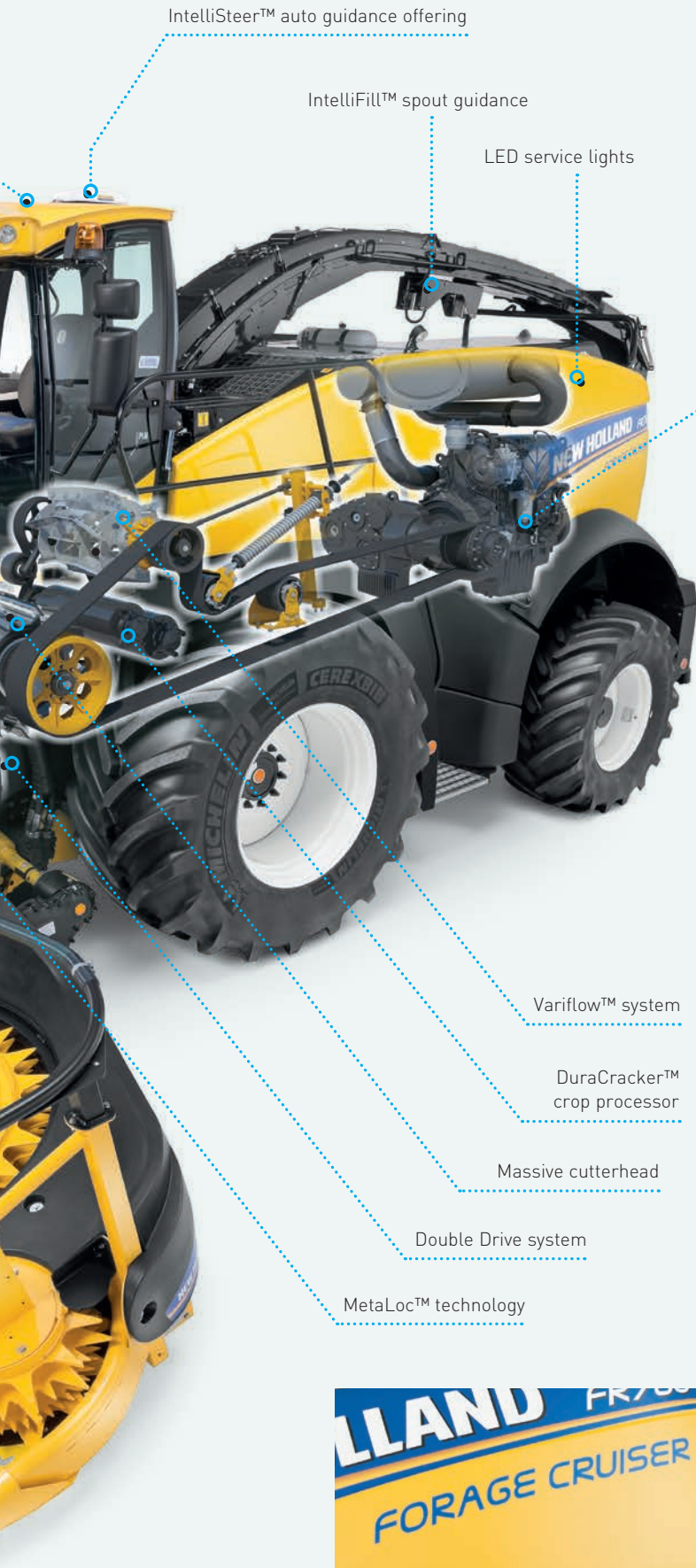

Scan to see the FR in action.

ECOBue™
HI-eSCR 2 engine

Lower operating costs

To lower your operating costs and increase your profits, the entire FR range is fitted with ECOBlue™ HI-eSCR 2 technology to comply with the most stringent Stage V emissions regulations to date. This technology also maintains the outstanding performance you've come to expect of FR Forage Cruisers. Advanced MetaLoc™ technology protects your FR from damaging metal, saving you money. The patented Variflow™ system can be changed from corn to hay position in under two minutes without the need for tools. Saving you time, earning you money. The FR: a money-making machine.

* Refers to official DLG certified test data.

Absolute driving pleasure

Experienced forage harvester operators are hard to find. The FR offers a first-class operating environment to make them want to stay. Front, back, or side to side, your view is uninterrupted to improve visibility for accurate crop pickup and discharge. The cab interior puts the operator at the heart of the machine. Plus, it boasts the ultra-wide IntelliView™ IV color touchscreen monitor to keep all key operating parameters under control. The available IntelliFill™ feature fills the trailer for you so you can concentrate on the serious business of driving. Welcome aboard!

Exactly what it says on the shielding

The level of FR Forage Cruisers performance is immediately obvious to all users. How? It's on the side shielding. The 'FR' stands for forage harvester, while the following three numbers, 780 for example, refer to the maximum harvesting power rounded to the nearest 10.

Revolutionizing forage harvesting.

In 1961, New Holland revolutionized forage harvesting mechanization. It transformed the highly successful pull-type forage harvester into our first self-propelled unit, the now legendary SP818. With this daring move, New Holland dramatically increased in-field performance. In line with this ambitious philosophy, over the last 60 years, New Holland has introduced a vast range of pioneering industry firsts to improve the profitability of your forage business. Today, the FR Forage Cruiser reflects New Holland's continuous and unwavering commitment to offer products that meet your most demanding requirements.

Dedicated engineers at the Zedelgem Center of Excellence

Today, over half a century after the first SP818 was designed and built in New Holland, Pennsylvania, a dedicated team of engineers based at New Holland's Harvesting Centre of Excellence in Zedelgem, Belgium is still committed to developing the next generation of forage harvesters. The sophisticated product development process and the extensive knowledge of a dedicated workforce in a world-class manufacturing facility ensure the FR line, together with all flagship harvesting products, the CR, CX and BigBaler lines, continue to set the harvesting benchmark.



Scan to take a look
behind the scenes of how
FR Forage Cruisers are built.



- 1961:** The SP818, New Holland's very first self-propelled forage harvester, available with a one-row corn header, set to work in the Pennsylvanian fields. The forage harvester revolution had begun.
- 1968:** The Model 1880 rolled off the production line. Power was increased and so was productivity.
- 1975:** With the Model 1890 the power race really took off. The very first 200-hp machine was unleashed, and new blowing technology enhanced unloading.
- 1977:** With the space race in full swing, the Model 1895 was the first forage harvester to offer built-in metal detection – protecting the machine and valuable cattle.
- 1979:** The Model 2100 featured the introduction of the in-line engine design and increased power up to 300 hp. Cab comfort and visibility were also improved.
- 1987:** Cutterhead protection, automatic knife sharpening, and the shearbar attachment were all some of the pioneering firsts introduced on the Model 1915.
- 1995:** The FX5 Series with up to 450 hp featured New Holland's first crop processing system.

- 1998:** Higher horsepower was being demanded for greater capacity, and the FX58 responded, with 571 hp.
- 2003:** The new millennium saw the advent of the FX series with HydroLoc™ feed roll drive for adjustable chop length on the go.
- 2007:** The FR9000 was awarded the prestigious "Machine of the Year" award at the Agritechnica Show in Germany.
- 2011:** Half a century of forage harvester leadership was celebrated by a limited-edition celebratory model.
- 2012:** The Forage Cruiser is unveiled, representing the pinnacle of forage harvester technology with industry leading chop quality and throughput.
- 2015:** The FR Forage Cruiser line is launched with new fuel-efficient engines and a spacious operator-focused cab.
- 2018:** The FR920, New Holland's most powerful harvester to date, is introduced including new features to the line.
- 2020:** Entire FR range fitted with HI-eSCR 2 technology for Stage V compliance.

1998



2003



2007



2007



2011



2012



2018



Powerful. With respect for you, for your farm, for the future.



FR Forage Cruisers benefit from the productivity-enhancing features of FPT Industrial Cursor 13, 16 and V20 engines equipped with Stage V-compliant ECOBlue™ HI-eSCR 2 technology. This system maintains the outstanding performance and fuel economy you've come to expect of the FR range. Through the Clean Energy Leader strategy, New Holland is committed to making agriculture more efficient while respecting the environment. The proven ECOBlue™ technology uses AdBlue to transform the harmful nitrogen oxides contained in the exhaust gas into harmless water and nitrogen. This after-treatment system is separate from the engine which means the engine only breathes clean, fresh air. The benefit? Clean-running, powerful units that offer improved performance and enhanced fuel economy.

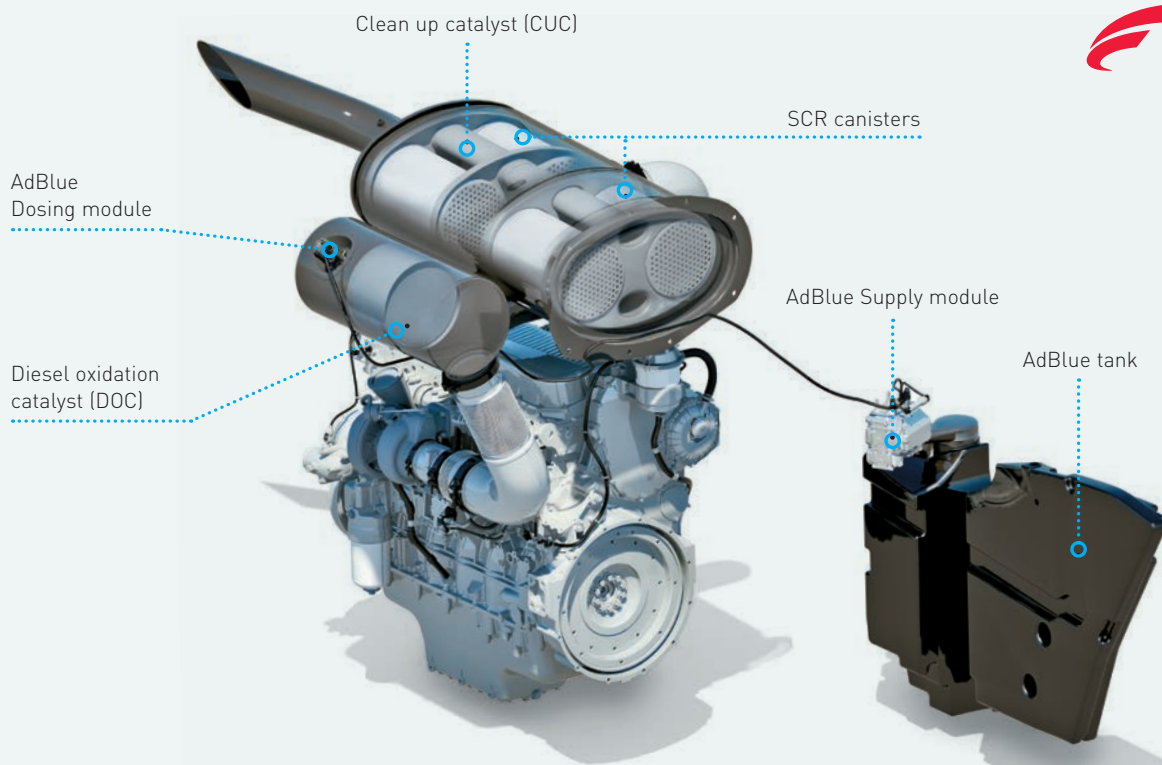

ECOBBlue™ HI-eSCR2

| Models | FR480 | FR550 | FR650 | FR780 | FR920 | |
|---|------------------|----------------|----------------|----------------|-------------|-------------|
| Engine | FPT Cursor 13* | FPT Cursor 13* | FPT Cursor 16* | FPT Cursor 16* | FPT V20* | |
| Displacement | cu. in. (L) | 787 (12.9) | 787 (12.9) | 970 (15.9) | 970 (15.9) | 1227 (20.1) |
| Injection system | Common Rail | Common Rail | Common Rail | Common Rail | Common Rail | |
| ECOBBlue™ HI-eSCR 2 system (Selective Catalytic Reduction) | ● | ● | ● | ● | ● | |
| Max. engine power @ 1700-1900 rpm ISO TR14396 - ECE R120 | [kW/ hp(CV)] | 350/476 | 400/544 | 480/653 | 570/775 | 670/911 |
| Maximum Torque @ 1500 rpm ISO 14396 - ECE R120 | ft. lbs. (Nm) | 1477 (2003) | 1708 (2316) | 2029 (2751) | 2451 (3323) | 3020 (4095) |
| Torque rise (2100 to 1700 rpm) | % | 35 | 34 | 35 | 33 | 44 |
| Approved biodiesel blend** | B5 | B5 | B5 | B5 | B5 | |
| Power Cruise™ II system | ● | ● | ● | ● | ● | |

● Standard ○ Optional — Not available *Developed by FPT Industrial

** Biodiesel blend must fully comply with the latest fuel specification EN14214:2009 and operation is in accordance with operator manual guidelines

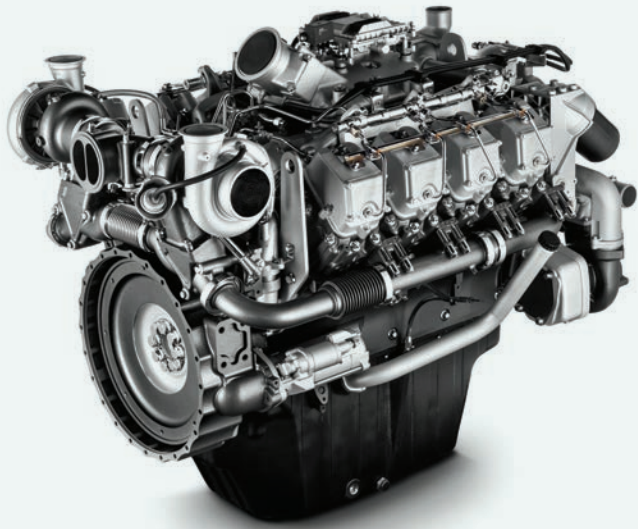

Powering the FR920

The FPT Industrial V20 engine powers the FR920, delivering a massive 911 horsepower and a productivity-boosting 44% torque rise to get through the tough spots in any field. The V20 engine is a 20.1L V-8 engine developed specifically for use in the FR920. The compact design fits nicely into the FR chassis and preserves the outstanding rear visibility of the range. The fuel efficient V-8 configuration requires many less moving parts than the V-12 engines used in competitive machines, and can be serviced from the ground.



Scan to learn more about the V20 engine.

Transient response

Here at New Holland we're passionate about transient response. You might think what's that? Quite simply, the FR Series power curve has been specifically mapped to match the precise requirements of foraging applications. When that is combined with ECOBlue™ HI-eSCR 2 technology, the FR's engine reacts quicker to changing load, so when you encounter a particularly dense area of the corn field, your engine will respond in the blink of an eye so you experience zero harvesting slow-down.

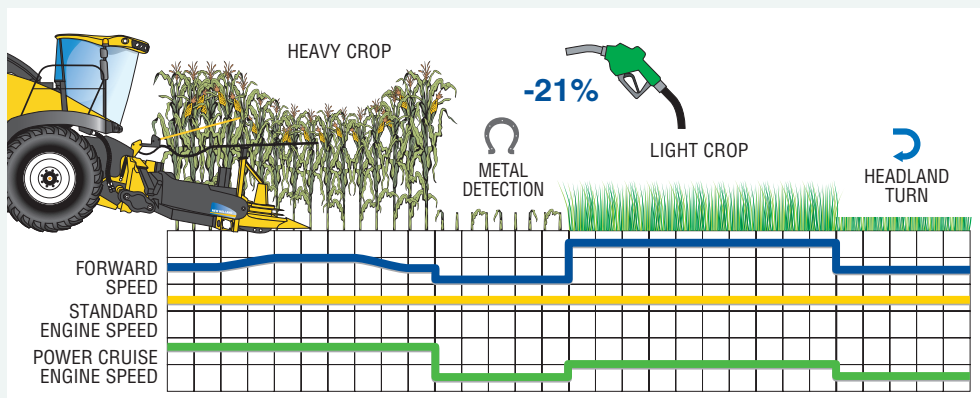
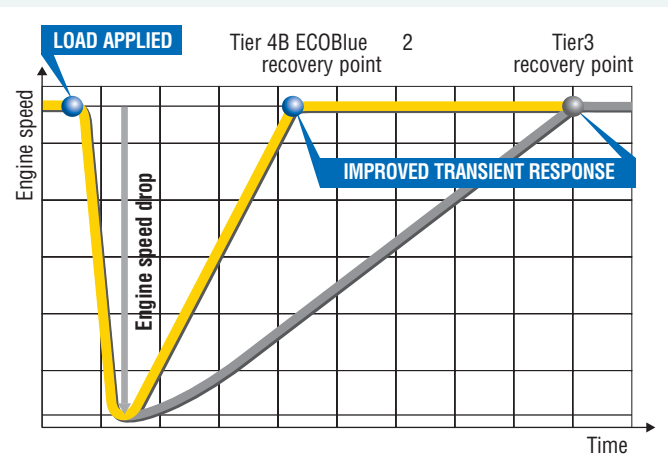

Automatic working modes for the highest work rates – Standard equipment

The new FR Forage Cruiser has two driving modes: Power Cruise™ and ECO engine management, which can be selected independently or used in conjunction with each other. Selection is based on crop conditions and operator preference.

The renowned Power Cruise™ II system automatically adapts engine and ground speed in relation to actual load for fuel savings of up to 15%. During periods of reduced load, during headland turns for example, engine speed is reduced to improve fuel efficiency. When throughput increases, so does engine speed to maintain a higher work rate. The new ECO engine management mode benefits from two settings, a high range where engine speed can be set between 2100 to 1950 rpm, ideal for chopping hay, and a low range which spans 1850 to 1700 rpm, which is perfect when working in corn.

Efficient power transfer.

In order to get the very most out of your FR Forage Cruiser, efficient power transmission from the engine to the driven parts, and ultimately to the cutterhead and ground, is a must. The in-line concept and direct driveline logic guarantee this and so much more.

Power dividing gearbox

The main gearbox splits engine power two ways: to the main clutch to drive the chopping components, and to the hydraulic and hydrostatic systems. The gear driveline allows each component to turn at the most efficient RPM for best performance. In use since the original FR introduction in 2007, the gearbox has a reputation for bulletproof reliability. The FR920 gearbox has a larger-diameter input shaft and improved bevel gear set to reliably transmit the higher horsepower of this model.

Double drive

This feature adds a second hydrostatic drive system that drives the header independently from the feedrolls. This arrangement allows the operator to change the header speed separately from the feedroll speed to fine-tune feeding in tough crop conditions. Double Drive is standard on FR550 through FR920 models and optional on FR480.

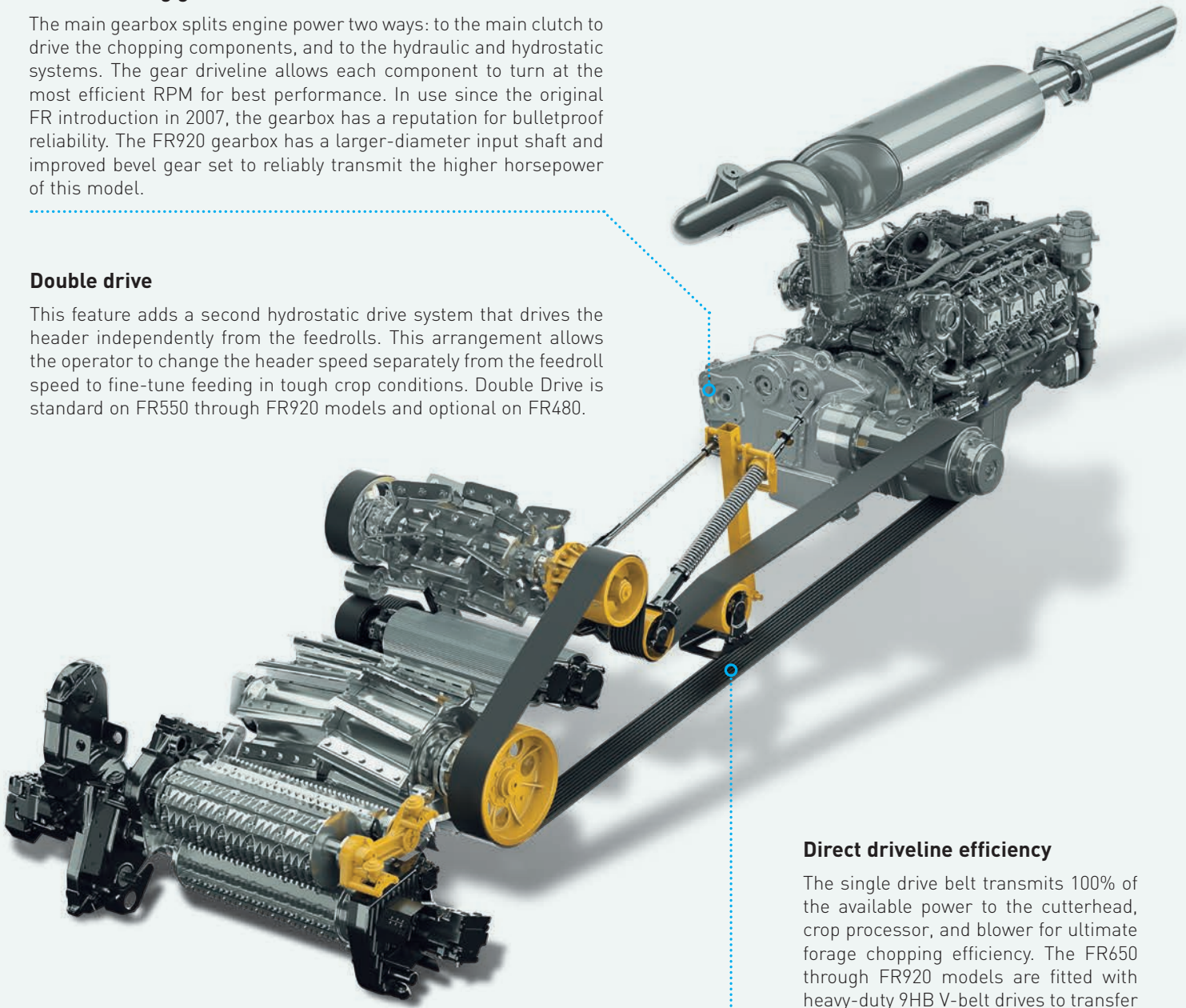

Direct driveline efficiency

The single drive belt transmits 100% of the available power to the cutterhead, crop processor, and blower for ultimate forage chopping efficiency. The FR650 through FR920 models are fitted with heavy-duty 9HB V-belt drives to transfer every last drop of performance. The main drive clutch is easily serviced, if needed, right from ground level.

Tire offering (FR480-FR780)

Forage Cruisers can be specified with a choice of three drive tire sizes to suit your individual needs. A 710/75R34 is offered for areas where a narrow overall width is important. For increased flotation, choose the huge footprint of the 900/60R32 tires. And for work in 30-inch rows, 520/85R42 dual tires will provide stability, flotation, and a great ride. Axle extensions can be used with the 710 and 900 tires to add track width for improved stability if overall transport width is not a concern. Forage cruiser models with 2WD steering axles have an empty heavy-duty rear axle housing and come with 710/55R30 steering tires. Units with dual front tires come equipped with 540/65R30 rear tires. Non-Dual tire units ordered with 4WD come with 600/65R28 or 710/55R30 for HD rear axles.

Tire offering (FR920)

The FR920 is offered with reinforced Michelin Cerexbib 900/60R32 tires in both two- and four-wheel drive versions. Two-wheel drive machines can also be ordered with 710/70R42 Mitas tire arrangement designed with 120-inch row centers. And for other row-crop work, 520/85R42 duals are available for great stability on contours and over pivot tracks.

Heavy-duty rear axle

A robust, heavy-duty rear axle is standard on the FR920 and an option on the FR780. The axle housing is common to both two- and four-wheel-drive units. Steering tires for units equipped with duals or 710 drive tires are 540/65R30 on offset rims designed for use on 120-inch centers. On four-wheel-drive machines with 900 tires, large 710/55R30 steering tires are fitted for flotation and an excellent ride. Four-wheel-drive FR920s feature beefed-up 4WD components to handle the extra weight and power of this model, and also feature TerraLock™, which automatically controls 4WD engagement depending on wheel slip and steering angle.

Super-tight turning

The FR's compact design and impressive 55° steering angle give it a turning circle of a mere 21 feet. This means smaller headlands for less time turning and more time harvesting. Furthermore, the tapered rear design ensures the harvester itself perfectly follows its rear wheels with zero overhang, making maneuvering and parking even easier.

Long and stable

The FR's ultra-long wheelbase ensures ultimate stability in the field and on the road. Up to four segmented 500-lb counterweights prevent bouncing during high-speed road transport when the header is still attached. High ground clearance, up to a full four inches more than the competition, prevents grounding when working in muddy, marginal conditions. Operations that work in the most extreme conditions and who are looking for year-round forage harvesting performance, will select the optional 100% mechanical four-wheel-drive option.



Top chop quality pays.

Enjoy industry-leading chop quality with the FR Forage Cruisers

This is a bold statement, but the FR can more than live up to it. With the widest chop channel components on the market from feedrolls to spout flipper, the crop mat at a given throughput is thinner and better controlled. This allows precision chopping and thorough processing so you can make the highest quality feed possible, whatever the crop. Your animals will produce more milk or meat all year long.



Widest feedrolls

The feedroll opening is 33.8 inches wide and up to 7 inches tall, giving an area of over 231 square inches to help swallow even the largest windrows efficiently. Standard anti-wrap filler sections on the top front feedroll help prevent wrapping in hay crops when backing out of the crop after a metal detection. Replaceable wear bars (optional on some configurations) on both upper and lower front feedrolls improve feeding and durability in tough harvesting conditions.



HydroLoc™ drive for consistent LOC

The Forage Cruisers' proven HydroLoc system provides on-the-go adjustment of LOC (length of cut). The feedrolls are driven by a powerful hydrostatic system that automatically matches the feedroll speed to the cutterhead's speed and knife configuration, providing a consistent chop length, even under varying loads and speeds. The selected LOC is displayed on the monitor and can be easily adjusted with a switch on the side console.



Protecting your harvest and your livestock

The state-of-the-art MetaLoc™ metal detection system features six detection zones which will bring the feedrolls to a dead halt within 300 milliseconds should metal be detected, to protect your FR and your customers' cattle. The metal's location will be pinpointed on the IntelliView™ IV monitor and the power reverser automatically flips open the pickup windguard and reverses the auger to positively eject the crop. The operator can even adjust the sensitivity of the system.

RockAlert™ Stone detection system

New RockAlert™ Stone detector system senses sudden feedroll movement and stops the crop flow to protect the cutterhead. You can adjust sensitivity to fine-tune to your local rock conditions.

Choice of cutterheads to match your requirements

The double-chevron cutterheads used in the Forage Cruisers offer outstanding chopping performance in all crops and conditions. The 35-inch-wide cutterhead is 28 inches in diameter, quite simply the largest on the market today. It is also the heaviest at approximately 1500 lbs, to provide plenty of inertia to process crop slugs efficiently and prevent shock-loads to the driveline. The chevron design cuts cleanly and begins the process of converging the crop mat into the crop processor or accelerator.

The popular 2x10 cutterhead provides a LOC range suitable for most North American harvesting requirements, but other configurations are available to meet almost any need.

| Cutterhead number of knives | Length of cut range |
|-----------------------------|---------------------|
| 2x8 | 6 - 33 (mm) |
| 2x10 | 5 - 26 (mm) |
| 2x12 | 4 - 22 (mm) |
| 2x16 | 3 - 16 (mm) |
| 2x20 | 2 - 13 (mm) |

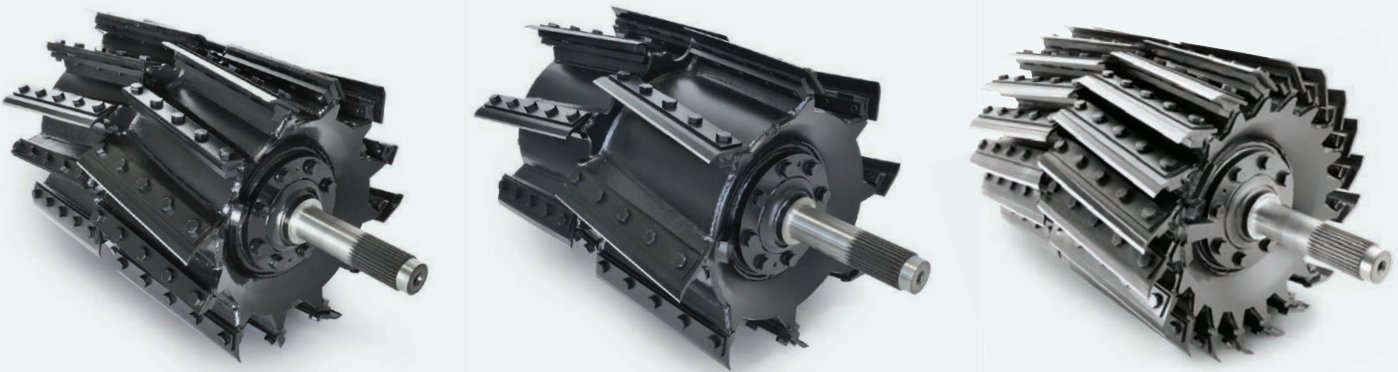

Grass or corn knives and shearbar

To fine-tune chopping performance, you can equip any FR cutterhead with grass or corn knives and matching shearbar to customize it to the crop and field conditions. Grass (universal) components are great for use in a wide variety of crops. They offer high abrasion resistance and won't easily chip if a small stone is mixed with the crop. Corn knives have a different, thinner profile with a steeper chopping angle to cut more efficiently. Like the corn shearbar, they are made of a harder material that will take a sharper edge and stay that way longer with high crop volumes going through the chopper.



Adjust-O-Matic™ automatic knife sharpening

Sharp knives ensure clean, precise cutting for maximum capacity from less power and fuel. With New Holland patented Adjust-O-Matic™ technology, you can easily sharpen knives and adjust the shearbar from the comfort of the cab. The knife sharpening system is now fully enclosed to ensure proper functioning in even the dirtiest harvesting conditions.



Scan to learn how to sharpen the knives and replace the sharpening stone.

Ultimate processing and blowing performance.

New Holland complements outstanding FR chop quality with unparalleled processing performance to provide your animals the best-quality feed.

Owners also want to quickly change the processor in or out of the crop flow to minimize unprofitable downtime when changing between crops. The FR delivers it courtesy of the industry-leading Variflow™ system.

Variflow™ technology

Variflow™ system technology has streamlined the processor to trailer crop flow, banishing stagnant crop, when harvesting grass, to the history books. The Variflow™ system enables the operator to alter the position of the blower depending on the crop being harvested. The patented system mounts the CP and the blower on a pivoting frame. When in corn position the CP is rotated into the crop stream for thorough kernel processing. When you change to the hay position, the CP swings rearward and the blower drops down to be closer to the cutterhead, eliminating the dead spots in the crop channel and enhancing blowing performance. The grass chute fills the gap above the blower.



Scan to learn more about the Variflow™ System

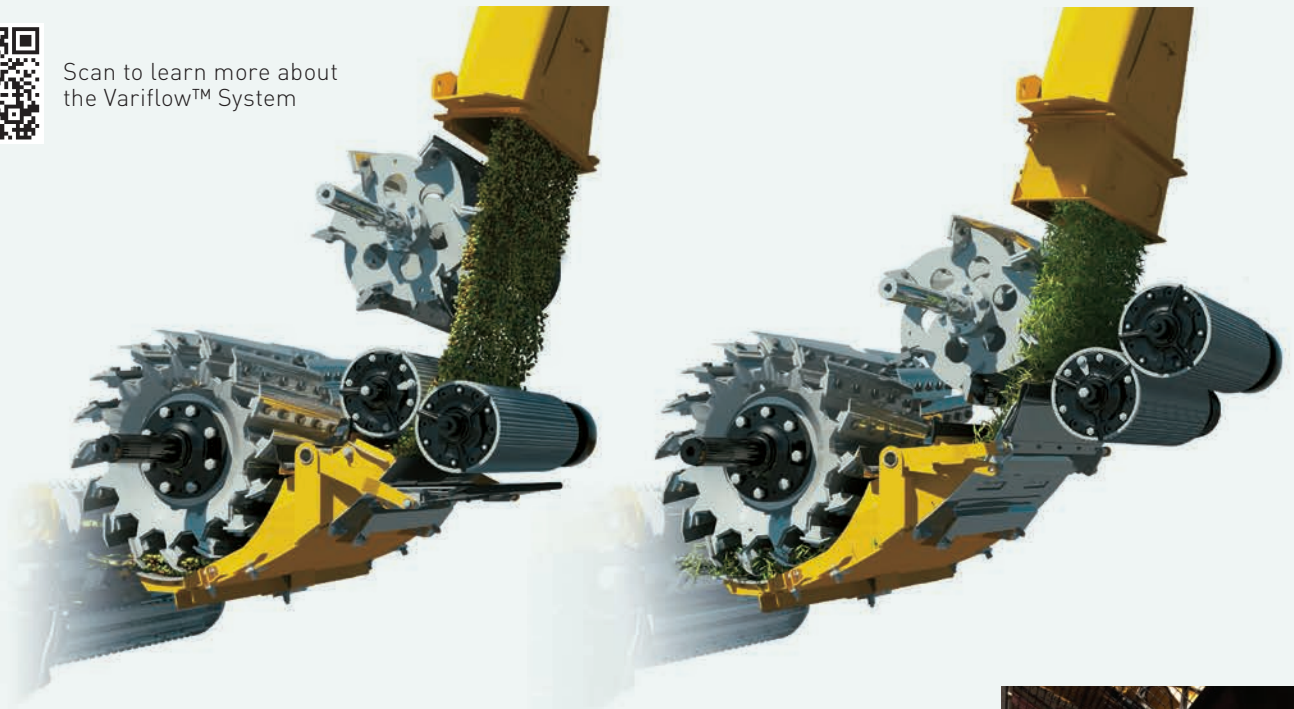

Two minutes. One person. Zero tools.

In under two minutes, and on your own, you can change the Variflow™ system from its corn to grass setting without the need for any tools—perfect when uttermost flexibility is of the essence in busy harvesting periods. Furthermore, an exclusive tensioning system ensures correct belt tension in both positions, so you don't need worry about it. During extended periods of hay chopping, you can remove the crop processor in under 20 minutes with the assistance of a dedicated hoist.



Scan to learn how to change the processor on the Variflow™ System



*New Holland recommends wearing Personal Protective Equipment (PPE) when appropriate.



Efficient crop processing

Both rolls are hard chrome coated to resist abrasion from dirt in the crop mat. Processing improvements come from the staggered tooth count on the rolls (99/126) and a 30% speed differential. The roll gap can be larger for higher throughput and still provide complete kernel processing for maximum feed efficiency.

DuraShredder™ heavy duty crop processing

The DuraShredder™ rolls have a spiral cut design, and the system itself is heavy-duty overall. The system effectively shreds the crop resulting in fluffy fibers. This is in response to customers who demand intensive processing of corn kernels and shredded stover when harvesting at lengths of cut above 7/8" (22mm).



Easy cleaning

The concave door can be opened via a button on the console when the machine is shut down. This enables better access to the concave channel for even easier cleaning. The door automatically closes when the engine is switched on. This feature is standard on all Forage Cruiser models.



DuraCracker™ heavy duty crop processing

The DuraCracker™ heavy-duty crop processing system is designed with reinforced frames and drives so that it delivers outstanding processing performance. It's a higher-intensity crop processing system designed to match the higher outputs of today's most powerful machines, such as the FR920.



| Models | | FR480 | FR550 | FR650 | FR780 | FR920 |
|--|----------|-------|----------------|-------|------------|-------|
| Standard Crop processor | | | | | | |
| Roll diameter | in. (mm) | ● | ● | ● | - | - |
| Two-roll system with saw tooth profile | teeth | | 9.8 (250) | | | |
| Width crop processor rolls | in. (mm) | | 99 / 126 / 166 | | | |
| DuraCracker™ Heavy Duty Crop processor | | | | | | |
| Roll diameter | in. (mm) | - | - | ○ | ● | ● |
| Two chrome roll system with DuraCracker™ saw tooth profile | teeth | - | - | | 100 / 130 | |
| Two chrome roll system with DuraShredder™ spiral cut tooth profile | teeth | - | - | | 110 / 145 | |
| Width crop processor rolls | in. (mm) | - | - | | 29.5 (750) | |

● Standard ○ Optional - Not available

Silky smooth crop flow.

Forage harvesting is a time-sensitive task. Good crop flow through the machine without plugging is important to keep the chopper and support vehicles moving and the harvest coming in. The FR Forage Cruiser has you covered with the Variflow system, adjustable grass door, the high-performance blower, and the widest spout in the industry.

Efficient headland management

The close proximity of the blower to the cutterhead means that two seconds after the crop has flowed into the pick-up it will be delivered into the truck. The result? Easier headland maneuvers, since the trailer is not trying to capture the last remnants of the crop coming out.

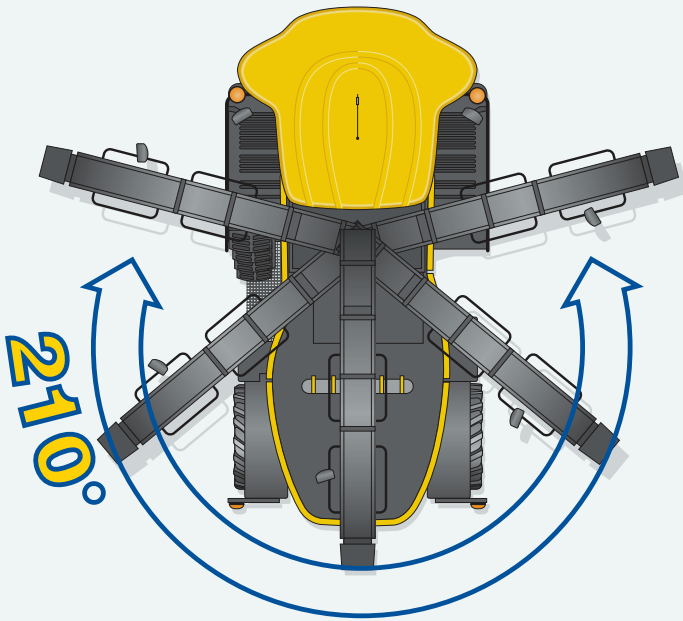

Exceptional 210° of spout rotation

The sleek black spout benefits from a full 210 degrees of rotation, which allows you to fill trucks both on the right and left sides of the harvester. The spout flipper is easy to see through the side windows – no need to duck your head. The spout is even more stable thanks to an additional support strut, which when coupled with stronger mounting points and additional braces, enables even more precise filling. The extra-long spout has a 21-foot elevation, which means you can use the highest trailers to reduce the number of trips for non-stop efficiency.



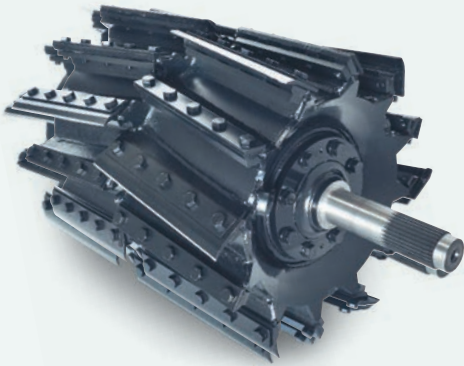

Cutting-edge blowing performance

The FR transfers higher volumes of crop more efficiently with our most advanced blower design yet. A 40% increase in the mass of smooth flowing air allows higher volumes of crop transfer, while smooth crop flow is supported by an impressive crop flow stability value of 80%. The FR's cutting-edge technology reduces turbulence and increases unloading efficiency.



Two spout choices fit your system

FR models can all be equipped with either the standard, long spout or with a short spout. The long spout is ideal for most applications where trucks or trailers are filled from their open tops. The short spout option is designed to fill enclosed truck or wagon bodies from the side or the front. Both spouts are a full 13-inches wide and feature a hydraulically operated flipper to put the crop where you want it. Grass (universal) and tapered corn flippers are available. Forage Cruisers also feature full length top and side liners with both spout styles. Heavy-duty abrasion resistant liners are an option if needed.

Farm with precision with New Holland.



Open. Connected. Smart. Supported. That's New Holland PLM™ at its best.

Whether factory fit or aftermarket, innovative solutions in precision farming and equipment automation increase the effectiveness of the machine and the value of harvested feed.

- **Guidance solutions** allow the operator to focus on the crop entering the machine, increasing consistency and minimizing field errors such as skips, misses or other misfeeding issues
- **Advanced automation solutions** such as preservative application work to ensure consistent crop harvest and increase RFV, while a feature like IntelliFill™ helps to reduce crop waste and crop left in the field
- **Telematics** allow monitoring of machine data to ensure peak harvest performance and also assist in remote diagnosis to minimize downtime
- **Telematics with file transfer** capabilities let you share boundaries and guidance lines with multiple machines simultaneously and send harvest information automatically to MyPLM™Connect for better visualization and management decision-making

PLM makes the FR even more impressive, letting you get the most out of your operation for higher profits and greater feed value.





Precise yield measuring

Crop throughput is calculated by continuously measuring the opening of the feedrolls and factoring in the width and speed of the crop mat. The yield can be displayed on one of the monitor's or via telematics to the MyPLM Connect Portal.



Scan to learn more about the yield monitoring system.

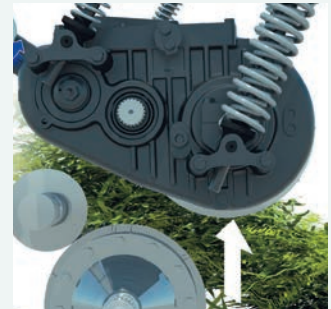

Real-time moisture sensing

The resistive type sensor uses three replaceable hardened contact pads to constantly measure the moisture in the feed flowing through the spout. The instant or average reading of the crop's water content can be displayed in the monitor.

Forage cruisers with yield and moisture systems can also be fitted with ActiveLOC™, a feature that will automatically vary the chopper's length of cut based on the changing moisture content of the crop. When harvesting fields with varying moisture, the LOC will decrease slightly in the drier sections and increase when in wetter areas. This ensures even packing and proper ensiling.



NutriSense™ NIR crop analysis sensing

The optional factory-installed NutriSense™ NIR sensor nutrient analysis technology is fully integrated into the IntelliView™ monitor allowing FR Forage Cruiser owners and operators to monitor and record a host of crop moisture and nutrient parameters in real time with outstanding accuracy within 2%. Monitored parameters include dry matter, crude protein, crude fat, starch, Neutral Detergent Fiber (NDF) and Acid Detergent Fiber (ADF). Crop analysis sensing is ideal when producing livestock feed or when working with the biomass industry.

Guidance and management solutions to match your needs.

Fully integrated IntelliSteer™ guidance*

All FR forage harvesters can be fitted with IntelliSteer™, New Holland's fully integrated auto guidance package. Fully compatible with the most accurate RTK and PLM RTK+ correction signals, IntelliSteer can guarantee pass-to-pass and year-to-year sub inch accuracy (under 2 cm). A variety of guidance paths, from straight A-B runs to the most complex adaptive curves can be programmed, as well as the advanced functionality which enables operators to transfer the guidance path from the tractor to the harvester for precision in-field operation. The result? Fields which are cleanly harvested, so every grain, blade of grass or kernel gets safely stored away.

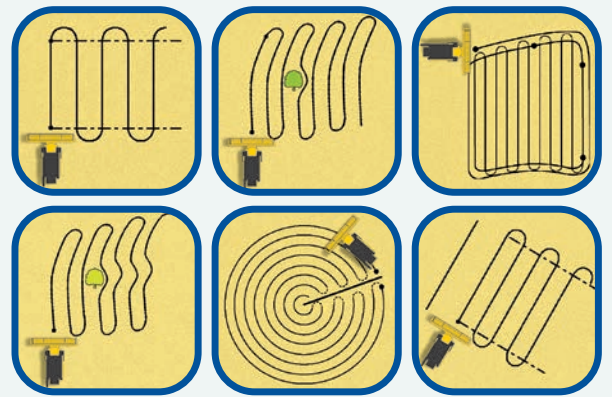

Always perfectly centered

Corn headers can be specified with row guidance to keep your FR perfectly on course. Two sensors continuously monitor the position of the crop entering the header, and automatically guide the machine to ensure true perpendicular entry even in poor visibility or at high speeds. The system can also be linked to a GPS positioning system, to facilitate night-time harvesting and advanced harvesting activities such as skip row functionality to ensure your header is always 100% full, 100% of the time.

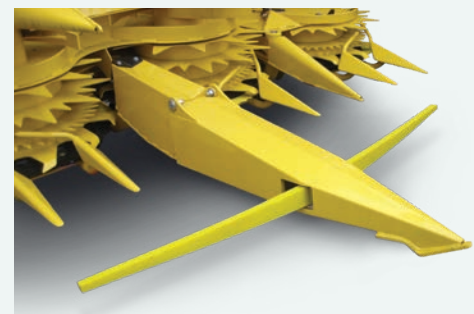

Let the FR Forage Cruiser fill the trailer for you

Operating a forage harvester requires extensive experience and a high level of concentration. For maximum focus on crop flow and field progress, the multi award-winning 3D camera-based IntelliFill™ system automatically detects the trailer edge and monitors filling. Whatever the trailer size or shape, it automatically controls the spout movement to perfectly fill right to the trailer's edges without spillages.

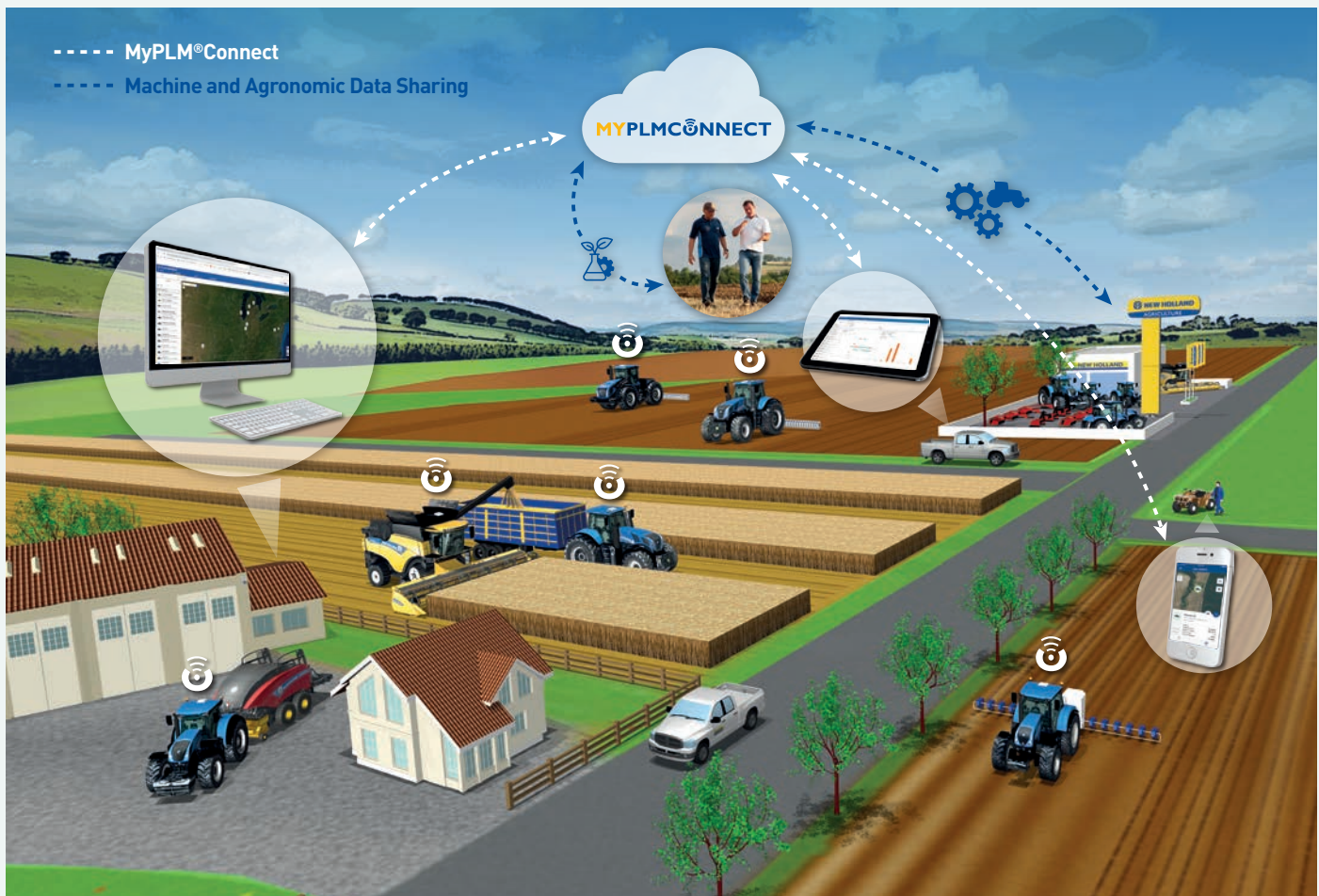

Telematics: Manage your machine from the comfort of your office

MyPLM™Connect lets you connect to your FR from the comfort of your office or through your mobile device from anywhere. Stay in touch with your machines and send and receive real-time information to save time and enhance productivity. The MyPLM™Connect Advanced Subscription not only provides full machine monitoring, but also includes file transfer so you can send or receive data files to or from your FR. Depending on options, files can include boundaries, guidance lines, speed, yield, moisture layers, and more. With MyPLM™Connect you'll know what is happening in your field and be able to make real-time decisions to better manage your operation.

Productive corn harvesting.

New Holland experts have developed a whole range of corn headers that have been custom designed for the FR line. Two drum choices meet different harvesting needs, and working widths range from 15' to 30'.

Small disc

The small disc corn headers, with 25-inch-diameter discs, have been designed to cleanly cut corn with a single drum handling each row when harvesting 30-inch rows. It cuts stalks cleanly and holds them in the gathering drums for transfer to the feedrolls. Small disc headers are available in six-, eight-, ten- and twelve-row versions. These headers also do a great job harvesting other standing crops, like barley, rye, wheat, and sorghum with minimal losses.



| Models | | 450SFI | 600SFI | 600BFI | 750SFI | 750BFI | 900SFI | 900BFI |
|-----------------------------|---------|----------|--------|--------|----------|----------|--------|--------|
| Working width | ft. (m) | 15 (4.5) | 20 (6) | 20 (6) | 25 (7.5) | 25 (7.5) | 30 (9) | 30 (9) |
| Number of corn rows | | 6 | 8 | 8 | 10 | 10 | 12 | 12 |
| Disc type | | Small | Small | Big | Small | Big | Small | Big |
| Row guidance | | ○ | ○ | ○ | ○ | ○ | ○ | ○ |
| Automatic lateral flotation | | — | ○ | ○ | ○ | ○ | ○ | ○ |
| Spout extension | | — | — | — | ○ | ○ | ○ | ○ |

○ Optional — Not available

Big disc

For harvesting tall, high-yielding corn, the large disc corn header is the best choice. Available in eight-, ten-, or twelve-row versions, the 53-inch-diameter discs cut through the tallest crops. These headers also work very well in wide-spaced corn and heavy-stemmed biomass crops.



Leading from the front.

Outstanding performance in hay

The old adage “you are what you eat” has never been more relevant than when talking about cattle. In order to produce the finest and most highly prized cattle and top-quality dairy herds, the highest quality silage with an exact nutritional profile must be fed. In order to deliver this to your customers, you have to harvest at exactly the right moment. You won’t get a second chance. With the 380FP hay pick-up you’ll get it right first time, every time.



| Models | 380FP |
|---|--------------------|
| Working width | ft. (m) 12.5 (3.8) |
| Rake windguard and fixed gauge wheels | ● |
| Paddle type auger with hydraulic lift system | ● |
| Hydraulic reel drive | ● |
| Rear support rollers | ● |
| Roller windguard and hydraulic movable gauge wheels | ● |

● Standard



Advanced header oscillation

No matter how uneven the terrain, uniform pick-up across the entire swath is guaranteed. Lateral free float technology in the base FR uses two heavy-duty springs which are built into the crop attachment frame and are used in conjunction with pickup headers to ensure unrivaled ground contour following. This system can be locked-out for silky smooth road transport.



Efficient feeding

A double-flighted paddle-type auger transfers the crop into the feed rollers. Active reel reverse is now standard and when the feedrolls and pick-up auger are reversed, a powered reversing action is automatically applied to the tine reel.

Enhanced reliability on uneven ground

Reinforced pick-up tines are fitted as standard to ensure optimum reliability when working on uneven or stony ground. The addition of rear pick-up support rollers prevents potentially damaging bulldozing when operating in uneven terrain. Robust castor wheels combine with the rear support wheel to maximize stability and contour following.

Super-fast pick-up

Reel speed and pick-up speeds have been increased to ensure maximum feeding performance.

Row-independent corn headers

Choose one of six row-independent corn headers to meet your operation's size. Headers are available in 6-, 8-, 10- and 12-row models in working widths up to 30'. The 8- and 10-row headers come in both small and large drum options. Tungsten carbide-coated saw blades self-sharpen while tearing through crop to reduce gearbox wear. And, as with all New Holland headers, corn units are fast and simple to hookup—one hydraulic quick-release lock can be hooked up even under pressure.

Your field office.

Spacious and quiet.

The FR Forage Cruiser line quite simply offers you a home away from home during long chopping days and nights. The cab provides the ultimate comfort with air-cooled leather seats, high back headrest, plenty of air vents, and sun screens. You can enjoy all the space the cab has to offer with a low sound level of just 76 decibels.



Easy access

Redesigned steps follow a natural arc to make access easy. The operator platform has been extended with the additional of sculpted handrails for safe entry and exit late at night and after long working days.



360° panoramic visibility

The FR cab's 360° wide curved windows offer a perfect view of the header and spout regardless of their position. The sculpted side-door glazed panels naturally follow the spout's unloading arc for a crystal-clear view during side discharge, and the curved rear window offers a great view to the back. The electric mirrors mean you can see in all directions, and they can be easily positioned from the comfort of the cab. Up to three viewing cameras can be managed through up to two IntelliView™ IV monitors. You can order a second display on the upper A-post as a factory-installed option. When loading, reversing or checking the trailer fill level, they are your second set of eyes.

Stay refreshed on the hottest days

During long hot harvesting days, the integrated fridge under the instructor seat will mean a refreshing drink is only ever an arm's length away. Plus, it can be easily removed for easy replenishment. The standard Automatic Climate Control system automatically adjusts fan speed to guarantee accurate temperature to within one degree of your setting. The FR is definitely the coolest place to be.



Are you sitting comfortably?

The top-of-the-line leather-trimmed seat features all the above as well as extended vertical travel and automatic weight adjustment to absorb even the most severe bumps. A seat heater and active ventilation offer the ultimate in operator comfort and style.

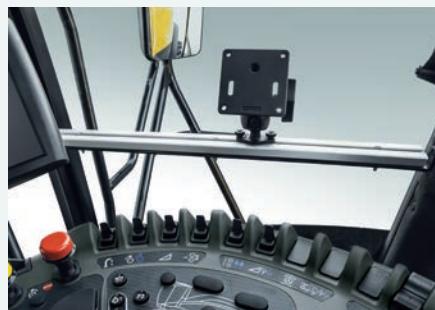

New mounting rail

A new mounting rail, conveniently positioned to the right of the armrest, can host a range of additional monitors and accessories.



Bright lights for dark nights

The FR lighting package offers up to 20 work lights, including 17 LED lights. In addition, 11 LED lights in the roof ensure the perfect spread of light. Six working lights illuminate key working areas, including the spout, service deck and on the bumper to enhance foraging accuracy when working in low-light conditions.

Effortlessly maximizing performance.

Intelligent and intuitive automation saves time and enhances harvesting performance. The CommandGrip™ multifunction lever is the primary interface that controls your FR. All key machine operating parameters can be managed including header controls, spout engagement and Power Cruise activation. The right-hand console contains less frequently used functions, which are laid out in an ergonomic and logical manner. Machine functions can be analyzed at a glance courtesy of the color IntelliView™ IV monitor.

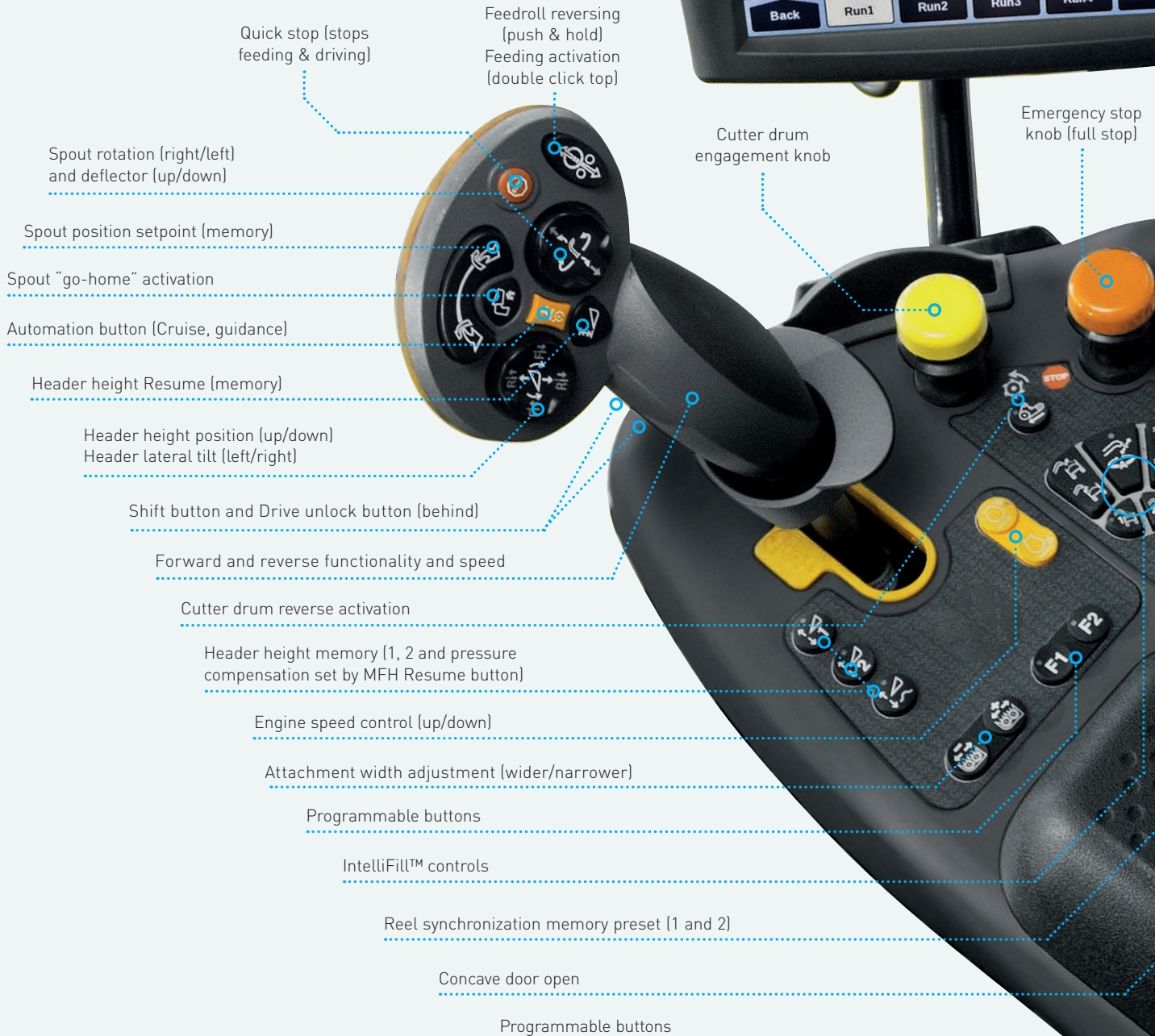



Wide-screen foraging

The standard, extra-wide 10.4-inch IntelliView™ IV monitor is mounted on the armrest and operators can position the monitor just where they like along the ideal viewing arc. This intuitive, color touchscreen displays and monitors all harvester functions and parameters which can be easily adjusted by simply touching the screen.



Charge on the go

Two USB charging points are now available to conveniently charge and power your mobile devices, so you can always stay connected.

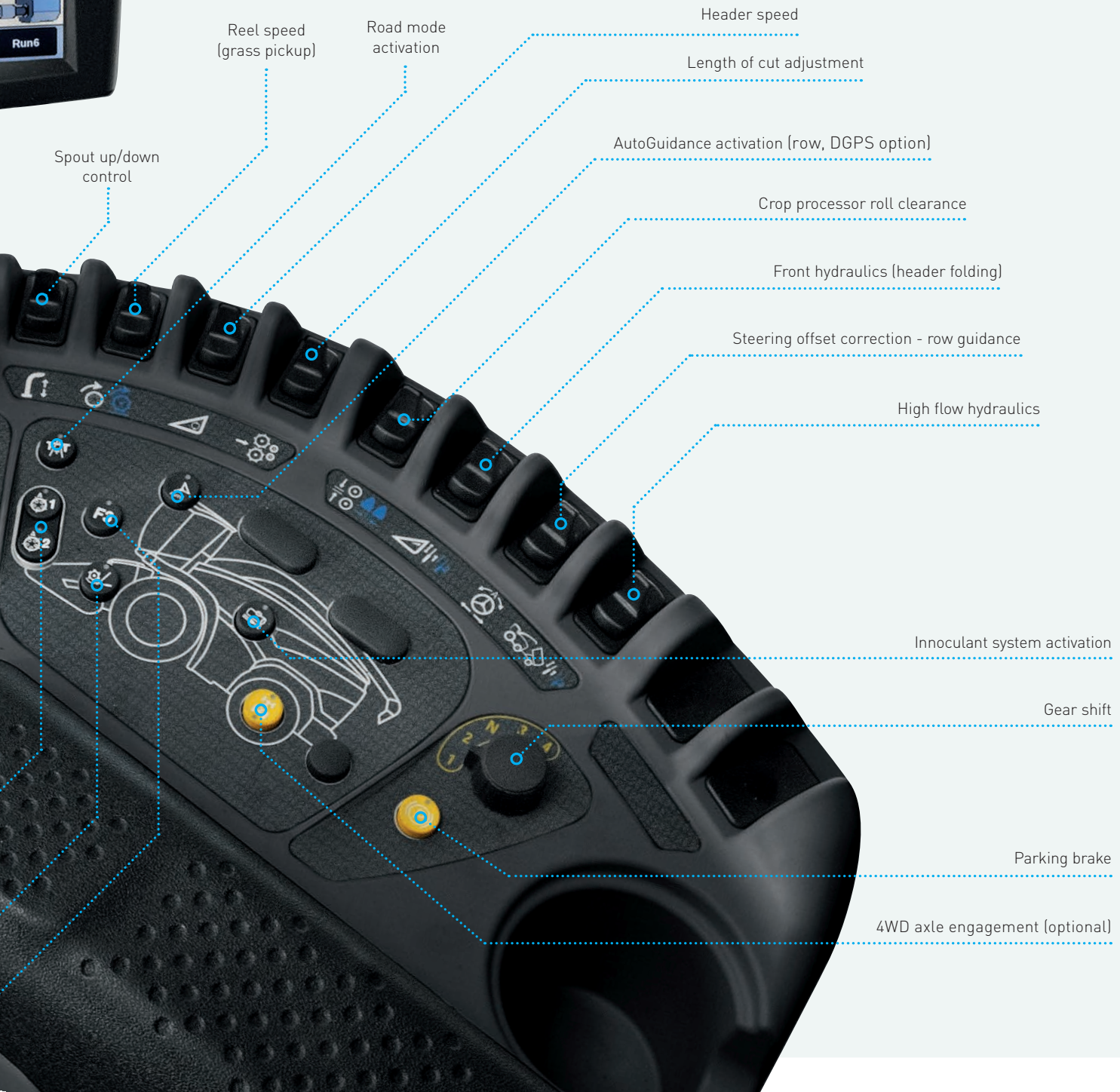

360°: FR Forage Cruiser.

The FR Forage Cruiser line has been designed to spend more time working and less time in the yard. After all, we all know how precious time is in the field during short harvesting windows. All service points are easy to access, and super-long service intervals mean the FR will spend more time in its natural environment: the field.



Undershield LED lighting package makes carrying out maintenance activities in low light levels even easier.



Convenient access to engine air filter.



The fuel and 52-gallon AdBlue tanks are conveniently located next to each other to facilitate simultaneous filling.



The dual air filters on the FR920 are accessed through doors on the top deck.



The centralized automatic greasing system is easy to access.

Heavy-duty wear-resistant plates can be fitted in the crop flow and on the full length of the spout to enhance durability when working in abrasive crops.



Bumper design includes integrated waterproof storage boxes and new easy-to-install counterweights.



Scan to learn how to lower the feedrolls for servicing.

Easily opened spout doors speed blockage clearing, and allow perfect access for wear liner replacement.

Self-supporting, fully opening single-piece side shields guarantee full access to all drives and service points.

The dedicated platform inside the FR makes cleaning the cooling package a snap.

The centralized drain ports enable super-fast and clean drainage when changing fluids.

Dealer-installed accessories

See your dealer about a comprehensive range of approved accessories to optimize machine performance.



| MODELS | | FR480 | FR550 | FR650 | FR780 | FR920 |
|--|---------------|--|--------------------|--------------------|--------------------|---------------------------|
| Engine | | FPT Cursor 13* | FPT Cursor 13* | FPT Cursor 16* | FPT Cursor 16* | FPT V20* |
| Engine configuration and number of cylinders | | In-line 6 | In-line 6 | In-line 6 | In-line 6 | V-8 |
| Displacement | cu. in. (L) | 787 (12.9) | 787 (12.9) | 970 (15.9) | 970 (15.9) | 1227 (20.1) |
| Injection system | | Common Rail | Common Rail | Common Rail | Common Rail | Common Rail |
| Compliant with engine emissions regulations | | Stage V | Stage V | Stage V | Stage V | Stage V |
| ECObLue™ HI-eSCR 2 system (Selective Catalytic Reduction) | | ● | ● | ● | ● | ● |
| Gross engine power @ 2100 rpm ISO TR14396 - ECE R120 | [kW/hp(CV)] | 320/435 | 370/503 | 440/598 | 530/721 | 610/830 |
| Max. engine power @ 1700-1900 rpm ISO TR14396 - ECE R120 | [kW/hp(CV)] | 350/476 | 400/544 | 480/653 | 570/775 | 670/911 @1600-1800 rpm |
| Torque @ 2100rpm ISO 14396 - ECE R120 | ft. lbs. (Nm) | 1073 (1455) | 1241 (1682) | 1476 (2001) | 1778 (2410) | 2046 (2774) |
| Torque @ 1700rpm ISO 14396 - ECE R120 | ft. lbs. (Nm) | 1450 (1966) | 1657 (2247) | 1988 (2696) | 2362 (3202) | 2950 (3999)** |
| Maximum Torque @ 1500 rpm ISO 14396 - ECE R120 | ft. lbs. (Nm) | 1477 (2003) | 1708 (2316) | 2029 (2751) | 2451 (3323) | 3020 (4095) |
| Torque rise (2100 to 1500 rpm) | % | 38 | 38 | 37 | 38 | 48 |
| Torque rise (2100 to 1700 rpm) | % | 35 | 34 | 35 | 33 | 44** |
| Approved biodiesel blend*** | | B5 | B5 | B5 | B5 | B5 |
| Power Cruise™ II system | | ● | ● | ● | ● | ● |
| Fuel consumption measuring and read-out on IntelliView™ IV monitor | | ● | ● | ● | ● | ● |
| Air compressor | | ○ | ○ | ○ | ○ | ● |
| Fuel tank | | | | | | |
| Diesel capacity | gal. (L) | Standard, 317 (1200) / Optional, 396 (1500) | | | | |
| AdBlue capacity | gal. (L) | 52 (200) | 52 (200) | 52 (200) | 52 (200) | 52 (200) |
| Feeding | | HydroLoc™ drive | HydroLoc™ drive | HydroLoc™ drive | HydroLoc™ drive | HydroLoc™ drive |
| Length of cut adjustment | | Infinite | Infinite | Infinite | Infinite | Infinite |
| Number of feed-rolls | | 4 | 4 | 4 | 4 | 4 |
| Feed opening width | in. (mm) | 33.9 (860) | 33.9 (860) | 33.9 (860) | 33.9 (860) | 33.9 (860) |
| MetaLoc™ metal detection with position indication | | ● | ● | ● | ● | ● |
| Dual Drive system (header hydrostatic drive) | | ○ | ● | ● | ● | ● |
| ActiveLOC™ active chop length control | | ○ | ○ | ○ | ○ | ○ |
| Cutterhead | | | | | | |
| Cutterhead cylinder type | | V-shaped with 2 rows of knives | | | | |
| Cutterhead frame width | in. (mm) | 35.4 (900) | 35.4 (900) | 35.4 (900) | 35.4 (900) | 35.4 (900) |
| Cutterhead cylinder width | in. (mm) | 34.8 (884) | 34.8 (884) | 34.8 (884) | 34.8 (884) | 34.8 (884) |
| Cutterhead diameter (max / min) | in. (mm) | 27.9 / 27.2 (710 / 690) | | | | |
| Cutterhead speed at 2100 engine rpm | rpm | 1130 | 1130 | 1130 | 1130 | 1130 |
| Cuts per minute (2x8 knives) | c/min | 9,060 | 9,060 | 9,060 | 9,060 | — |
| Length of cut range (2x8 knives) | in. (mm) | 0.2 - 1.3 (6 - 33) | 0.2 - 1.3 (6 - 33) | 0.2 - 1.3 (6 - 33) | 0.2 - 1.3 (6 - 33) | — |
| Cuts per minute (2x10 knives) | c/min | 11,320 | 11,320 | 11,320 | 11,320 | 11,320 |
| Length of cut range (2x10 knives) | in. (mm) | 0.2 - 1 (5 - 26) | 0.2 - 1 (5 - 26) | 0.2 - 1 (5 - 26) | 0.2 - 1 (5 - 26) | 0.2 - 1 (5 - 26) |
| Cuts per minute (2x12 knives) | c/min | 13,600 | 13,600 | 13,600 | 13,600 | 13,600 |
| Length of cut range (2x12 knives) | in. (mm) | 0.2 - 0.9 (4 - 22) | 0.2 - 0.9 (4 - 22) | 0.2 - 0.9 (4 - 22) | 0.2 - 0.9 (4 - 22) | 0.2 - 0.9 (4 - 22) |
| Adjust-O-Matic™ shearbar setting | | ● | ● | ● | ● | ● |
| Automatic knife sharpening system in forward or reverse | | ● | ● | ● | ● | ● |
| Variflow™ system | | Shift between crops in under two minutes | | | | |
| Crop processor | | | | | | |
| Roll Width | in. (mm) | 29.5 (750) | 29.5 (750) | 29.5 (750) | 29.5 (750) | 29.5 (750) |
| Roll diameter | in. (mm) | 9.8 (250) | 9.8 (250) | 9.8 (250) | 9.8 (250) | 9.8 (250) |
| Cab Controlled Gap | | ● | ● | ● | ● | ● |
| Standard CP | | ● | ● | ● | — | — |
| Rolls | | Sawtooth, 99/126 teeth, 30% Differential | | | | — |
| DuraCracker HDCP | | — | — | ○ | ● | ● |
| Rolls | | HD Sawteeth, 100/130 teeth, 30% Differential | | | | — |
| DuraShredder HDCP | | — | — | ○ | ○ | ○ |
| Rolls | | HD Spiral Cut Sawteeth 110/145 | | | | — |
| Blower | | | | | | |
| Blower rotor diameter | in. (mm) | 20.7 (525) | 20.7 (525) | 20.7 (525) | 20.7 (525) | 20.7 (525) |
| Blower rotor width | in. (mm) | 29.5 (750) | 29.5 (750) | 29.5 (750) | 29.5 (750) | 29.5 (750) |
| Blower speed at 2100 engine rpm | rpm | 2119 | 2119 | 2119 | 2119 | 2119 |
| Spout | | | | | | |
| Spout maximum height | in. (mm) | 252 (6400) | 252 (6400) | 252 (6400) | 252 (6400) | 252 (6400) |
| Rotation angle | degree | 210 | 210 | 210 | 210 | 210 |
| Spout extension (10-row corn header) | in. (mm) | 28.3 (720) | 28.3 (720) | 28.3 (720) | 28.3 (720) | 28.3 (720) |
| Spout extension (12-row corn header) | in. (mm) | 54 (1380) | 54 (1380) | 54 (1380) | 54 (1380) | 54 (1380) |
| Automatic spout functions (home and work positions) | | ● | ● | ● | ● | ● |
| Spout side collision protection | | ● | ● | ● | ● | ● |
| Electrical | | | | | | |
| 12 volt alternator standard | Amps | 240 | 240 | 240 | 240 | 240 |
| Battery capacity | CCA / Ah | 2 x 800 / 107 | 2 x 800 / 107 | 3 x 800 / 107 | 3 x 800 / 107 | 4 x 800 / 107 |

| MODELS | | FR480 | FR550 | FR650 | FR780 | FR920 |
|--|-----------|----------------|----------------|----------------|----------------|----------------|
| Transmission | | | | | | |
| Hydrostatic | | ● | ● | ● | ● | ● |
| Gearbox | | 4-speed | 4-speed | 4-speed | 4-speed | 4-speed |
| Remote gearshifting | | ● | ● | ● | ● | ● |
| Differential lock | | — | ● | ● | ● | ● |
| Mechanical 4WD System | | ○ | ○ | ○ | — | — |
| Heavy-Duty Mechanical 4WD system with Terralock™ traction management | | — | — | ○ | ○ | ○ |
| Maximum road speed @ 1400 rpm | mph (kph) | 25 (40) | 25 (40) | 25 (40) | 25 (40) | 25 (40) |
| Header control systems | | | | | | |
| Pressure compensation mode | | ● | ● | ● | ● | ● |
| Autofloat™ system | | ○ | ○ | ● | ● | ● |
| Mechanical Lateral flotation | | ● | ● | ● | ● | ● |
| Power Reverse hydraulic header reverser | | ● | ● | ● | ● | ● |
| Hydraulic quick coupler (single location) | | ● | ● | ● | ● | ● |
| Automatic header speed synchronization to forward speed | | ● | ● | ● | ● | ● |
| Cab glass area | ft² (m²) | 240 (6.8) | 240 (6.8) | 240 (6.8) | 240 (6.8) | 240 (6.8) |
| Cab category level - EN 15695 | | 1 | 1 | 1 | 1 | 1 |
| LEO lighting pack | | ○ | ○ | ○ | ○ | ○ |
| Optimum cab noise level - ISO 5131 | [dB(A)] | 76 | 76 | 76 | 76 | 76 |
| Leather trimmed heated air-suspension seat with Active Ventilation | | ● | ● | ● | ● | ● |
| Instructor's seat | | ● | ● | ● | ● | ● |
| CommandGrip™ handle | | ● | ● | ● | ● | ● |
| IntelliView™ IV monitor with adjustable position | | ● | ● | ● | ● | ● |
| Reversing camera | | ○ | ○ | ○ | ○ | ○ |
| Automatic climate control | | ● | ● | ● | ● | ● |
| Removable coolbox | | ○ | ○ | ○ | ○ | ○ |
| Air horn [dual-trumpet, 150/180Hz, 112dB(A)] | | ○ | ○ | ○ | ○ | ○ |
| Automatic greasing system | | ● | ● | ● | ● | ● |
| Rear bumper with integrated water proof storage boxes | | ● | ● | ● | ● | ● |
| New Holland Precision Land Management systems | | | | | | |
| PLM® Connect Telematics | | ○ | ○ | ○ | ○ | ○ |
| Guidance systems | | | | | | |
| IntelliSteer® system | | ○ | ○ | ○ | ○ | ○ |
| Automatic row guidance system for corn headers | | ○ | ○ | ○ | ○ | ○ |
| IntelliFill™ system (automated side/rear trailer filling) | | ○ | ○ | ○ | ○ | ○ |
| Precision farming | | | | | | |
| Optional additive tank (with adjustable flow) capacity | gal. (L) | 100 (395) | 100 (395) | 100 (395) | 100 (395) | 100 (395) |
| Moisture measuring | | ○ | ○ | ○ | ○ | ○ |
| Yield measuring and moisture measuring | | ○ | ○ | ○ | ○ | ○ |
| NurtriSense™ NIR sensor nutrient analysis technology | | ○ | ○ | ○ | ○ | ○ |
| Full Precision farming package including: | | | | | | |
| Yield measuring and moisture measuring, DGPS yield mapping | | ○ | ○ | ○ | ○ | ○ |
| Weight**** | lbs. (kg) | 28,775 (13050) | 28,880 (13100) | 29,875 (13550) | 30,100 (13650) | 34,800 (15800) |

● Standard ○ Optional — Not available *Developed by FPT Industrial **Engine speed @ 1600 rpm

*** Biodiesel blend must fully comply with the latest fuel specification EN14214:2009 and operation is in accordance with operator manual guidelines ****Base grass configuration

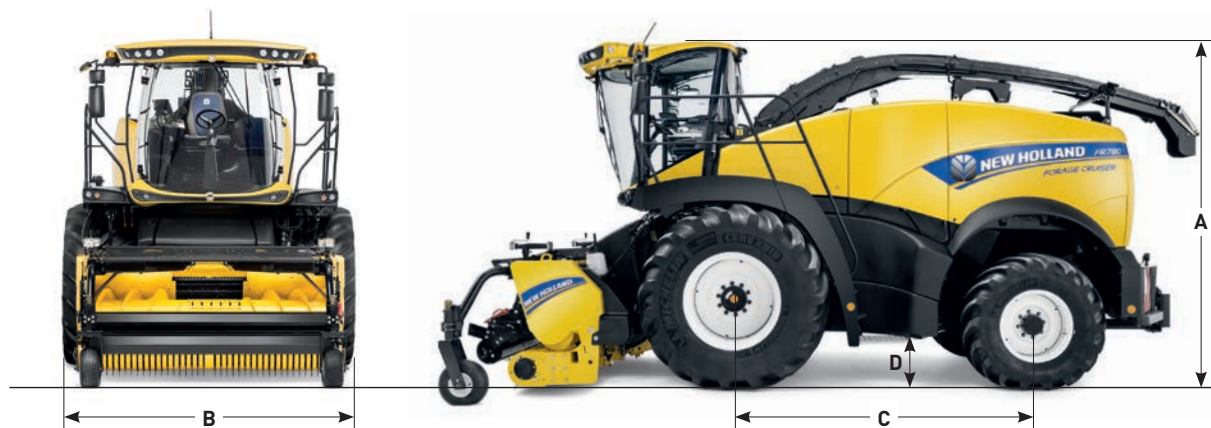

| MODELS | | 710/75R34 | 900/60R32 | 520/85R42 |
|---|----------|-------------|-------------|-------------|
| With traction wheels ^(A) | | | | |
| Turning radius | ft. (m) | 21 (6.4) | 21 (6.4) | 21 (6.4) |
| A - Maximum height in transport position | ft. (m) | 12.4 (3.77) | 12.3 (3.76) | 12.4 (3.79) |
| B - Maximum width - transport | ft. (m) | 10.3 (3.15) | 11.3 (3.45) | 16.6 (5.06) |
| C - Wheelbase | ft. (m) | 10.5 (3.2) | 10.5 (3.2) | 10.5 (3.2) |
| D - Ground clearance | in. (mm) | 19 (500) | 19 (500) | 19 (500) |

(A) Traction wheels other than those mentioned are also available: 800/70R32, 800/65R32. Max width: 800/70R32 = 3,35m; 900/60R32 = 3,48m; 710/70R42 = 3,19m; 80/70R38 = 3,29m.



VALUE, SERVICE AND SOLUTIONS

There's a certain way of thinking that comes from living on a farm. Farming takes equal parts brain and brawn. Not to mention thick skin, calloused hands and a fair share of know how. Seasoned farmers know it helps to have equipment that's built by farmers, sold by farmers and used by farmers.

Support at every step. When you place your confidence in New Holland agricultural equipment, you get the finest in local support. Your New Holland dealer understands the many challenges you face and stands behind you at every step with the equipment, parts, service and financial solutions to make your job easier. Look to New Holland for a complete selection of equipment, including a full line of tractors, hay & forage equipment, harvesting, crop production and material handling equipment.

Quality parts and service. Turn to your New Holland dealer after the sale for expert, factory-trained service and genuine New Holland-branded parts. Your dealer has the very latest service updates and training to ensure your equipment keeps working productively season after season.

Financing solutions. Your New Holland dealer can tell you about smart ways to turn your financial challenges into opportunities with a portfolio of innovative financial services available through CNH Industrial Capital, including customized financing, leasing, insurance and the purchasing convenience of a Commercial Revolving Account.

For reliable equipment, parts and service — or just honest advice on farming and finance — turn to New Holland and your trusted New Holland dealer. We know. We're farmers, too.



We are proud to support the FFA.

Learn more at www.newholland.com

Design, materials and/or specifications are subject to change without notice and without liability therefor. Specifications are applicable to units sold in Canada, the United States, its territories and possessions, and may vary outside these areas.

© 2021 CNH Industrial America LLC. All rights reserved. New Holland is a trademark registered in the United States and many other countries, owned by or licensed to CNH Industrial N.V., its subsidiaries or affiliates. Any trademarks referred to herein, in association with goods and/or services of companies, other than owned by or licensed to CNH Industrial N.V., its subsidiaries or affiliates, are the property of those respective companies.



Safety begins with a thorough understanding of the equipment. Always make sure you and your operators read the Operator's Manual before using the equipment. Pay close attention to all safety and operating decals and never operate machinery without all shields, protective devices and structures in place.