

## 1. Description

The COM Module PLUS is compatible with E-MAAX PRO and PLUS series regulators. It provides four functions;

1. A USB connection point for a PC to display system data, and to read or modify the regulator settings;
2. A Bluetooth connection point for a PC when USB is not available. When connected to a PC via Bluetooth link, only system status display is available (no "write" capability).
3. Houses the Field Reduction Switches (FRS) which commands the regulator to reduce the alternator's field coil current (Field output) in 10% increments down to 30% of its nominal value for the current charging conditions. Such reduction reduces engine load in conditions where maximum engine power is desired.
4. Provides both a Fault LED and an audible alarm that sounds (ISO -2 seconds) when the system is in a critical fault condition. A "critical" fault will reduce the alternator output to 10% until the fault condition is resolved. The audible alarm will continue to sound until the fault is resolved. Field output is restricted to 10% in order to avoid damage to the charging system. The system is placed into the Fault condition due to one or more of the following conditions:
  - a) The battery's temperature reaches 50°C
  - b) The alternator's temperature reaches 100°C
  - c) The regulator's temperature reaches 90°C
  - d) In-line fuse on the power supply line is blown
  - e) Overvoltage

There are two buttons on the Com Module PLUS. The "UP" (green) button increases the Field output, and the "DOWN" (white) button decreases it. Short depression of either button changes the Field output by 10% increments in the respective direction. Holding down the white button for two seconds cuts the Field output by 50%. Holding down the green button for two seconds restores the Field output to 100%. The green FRS (**F**ield **R**eduction **S**witch) LED provides a visual indication of the switch status state by the frequency of flashes listed in the table below. When the engine ignition is switched off, the FRS LED indicator is not lit and the FRS is re-set to 100%.

The green USB LED or the blue BT ⌘ (Bluetooth) LED provides a visual indication of the data exchange between the PC and the Com Module PLUS.

## 2. Dimensional outline

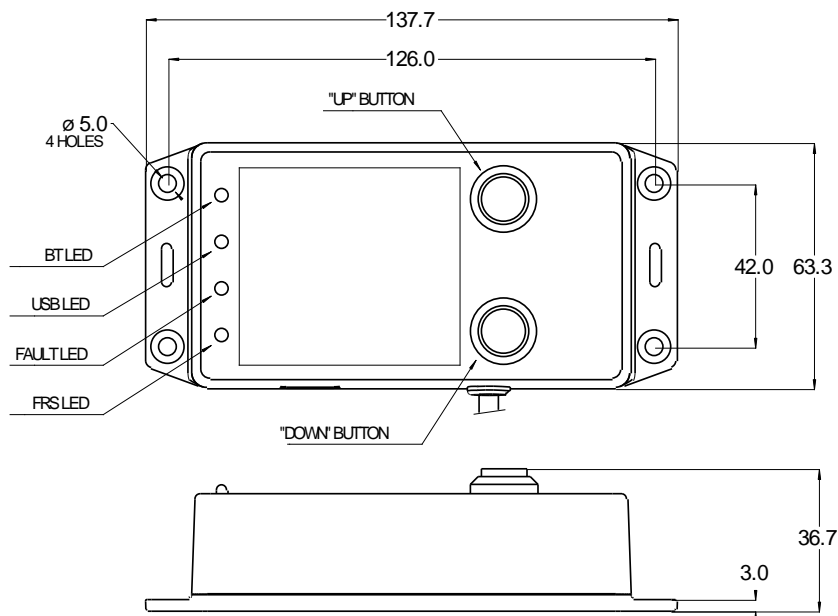

All units are millimeters

### 3. Specifications

Parameter	Value	Units
Weight	200	grams
Housing material	PVC	-
Operating range	-20 .. +80	Celsius deg
Protection	IP 56	-
Maximum allowable shock	3	G
Maximum allowable relative humidity	95	%

### 4. Electrical specifications

Parameter	Value	Units
DC voltage supply range	6 .. 20	Volts
Current consumption	0.020	Amps
BT  LED color	Blue – connection / data exchange	-
USB LED color	Green– data exchange	-
Fault LED color	Red – indicates critical fault	
FRS LED color	Green – indications see below	
FRS - Visual indication flashing frequencies	Field Reduction Switch inactive – 0.5 10% reduction – 1 20% reduction – 2 30% reduction – 3 40% reduction – 4 50% reduction – 5 60% reduction – 6 70% reduction - 7	Hz
Cable ratings	Gauge: 20 AWG Material: tinned copper strands Strand size: Ø 0.16 mm Insulator Material: PVC Jacket Color: black Diameter: 5.5 mm	-
Communications format	RS-485	-
Wire colors designations	black – battery negative (isolated from the housing) red – DC supply (isolated from the housing) white – communication lead "A" yellow – communication lead "B"	-
Connector pin-out	1 - black – battery negative 2 - red – DC supply 3 - white – communication lead "A" 4 - yellow – communication lead "B"	-

4-pin connector pins, view from the cable side (insertion)

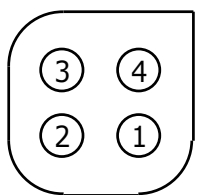

### 5. USB connection to a PC

The COM Module PLUS is compatible with "Windows 7" or higher operating systems and does not require any special drivers. All the required driver files are a part of the operating system, and load automatically when the device is plugged in the first time.

The USB connection has priority over the Bluetooth connection and will disconnect the Bluetooth when USB connection is established. The regulator settings can only be modified through a USB connection.

The USB LED will flash during data exchange with Com Module PLUS.

### 6. Bluetooth connection to a PC

The COM Module PLUS is compatible with "Windows 7" or higher operating systems and does not require any special drivers. All the required driver files are a part of the operating system, and load automatically when the device is plugged in the first time. When powered and the USB cable is NOT plugged in, the device enters the Bluetooth discovery and pairing mode (slow flash). When trying to pair, device scan must show "E-MAAX Com Module+". Use "1234" as the pairing pin-code. The Bluetooth LED will be steady during data exchange with the Com Module PLUS.

## REGULATORY APPROVAL

This section outlines the regulatory information for the COM Module PLUS for the following countries:

### United States

Contains FCC ID: T9J-RN42.

This device complies with Part 15 of the FCC Rules. Operation is subject to the following two conditions: (1) this device may not cause harmful interference, and (2) this device must accept any interference received, including interference that may cause undesired operation.

This equipment has been tested and found to comply with the limits for a Class B digital device, pursuant to part 15 of the FCC Rules. These limits are designed to provide reasonable protection against harmful interference in a residential installation. This equipment generates, uses and can radiate radio frequency energy, and if not installed and used in accordance with the instructions, may cause harmful interference to radio communications. However, there is no guarantee that interference will not occur in a particular installation. If this equipment does cause harmful interference to radio or television reception, which can be determined by turning the equipment off and on, the user is encouraged to try to correct the interference by one or more of the following measures:

- Reorient or relocate the receiving antenna.
- Increase the separation between the equipment and receiver.
- Connect the equipment into an outlet on a circuit different from that to which the receiver is connected.
- Consult the dealer or an experienced radio/TV technician for help.

### Canada

Contains transmitter module IC: 6514A-RN42

This device complies with Industry Canada license exempt RSS standard(s). Operation is subject to the following two conditions: (1) this device may not cause interference, and (2) this device must accept any interference, including interference that may cause undesired operation of the device. Under Industry Canada regulations, this radio transmitter may only operate using an antenna of a type and maximum (or lesser) gain approved for the transmitter by Industry Canada. To reduce potential radio interference to other users, the antenna type and its gain should be so chosen that the equivalent isotropically radiated power (e.i.r.p.) is not more than that necessary for successful communication.

Under Industry Canada regulations, this radio transmitter may only operate using an antenna of a type and maximum (or lesser) gain approved for the transmitter by Industry Canada. To reduce potential radio interference to other users, the antenna type and its gain should be so chosen that the equivalent isotropically radiated power (e.i.r.p.) is not more than that necessary for successful communication.

**European Union**

<b>Certification</b>	<b>Standards</b>	<b>Article</b>	<b>Laboratory</b>	<b>Report Number</b>	<b>Date</b>
Safety	EN 609501:2006 + A11:2009 + A1:2010 + A12:2011	[3.1(a)]	Worldwide Testing Services (Taiwan) Co., Ltd	W6M21402-13966-L	2014-03-24
Health	EN 62479:2010			W6M21402-13966-62479	2014-03-13
EMC	EN 301 489-1 V1.9.2 (2011-09) EN 301 489-17 V2.2.1 (2012-09)	[3.1(b)]		W6M21402-13966-E-16	2014-03-13
Radio	EN 300 328 V1.8.1 (2012-06)	(3.2)		W6M21402-13966-T-45	2014-03-13
Notified Body Opinion	CE0681	-	Eurofins Product Service GmbH	U9M-1404-3736-C-V01	2014-04-15

**Notice**

ElectroMaax reserves the right to make product modifications or discontinue products without notice. Customers are advised to obtain latest written specifications prior to ordering products. Information provided by ElectroMaax is believed to be accurate at the time of its release. Products sales are subject to the ElectroMaax Terms of Sales in force at the time of order acknowledgment. ElectroMaax products are not designed, authorized, or warranted for use in life support devices and systems, or any other critical applications which may involve death, injury, property or environmental damages. Using ElectroMaax products for any critical application is fully at the risk of the customers and their end users and assigns.