

**1. Description**

*Battery Voltage Sensor* is a part of the E-MAAX regulator systems; it measures voltage across the batteries and reports the measured values to the connected regulator. It is compatible with E-MAAX PRO and PLUS series regulators. The Voltage Sensor is designed to be connected directly onto battery posts 8mm (5/16") lug connectors (non-polarity specific). When connecting, care must be taken to provide good electrical contact between the posts and the sensor. Sensor's LED provides a visual indication that the sensor is connected to the regulator, it flashes once in 2 seconds.

**2. Specifications**

Parameter	Value	Units
Measured voltage range on each lead	-5 .. +50	Volt
Measurement accuracy	0.01	Volt
Weight	200	grams
Housing material	Plastic, black	-
Lug connector size	8mm or 5/16"	-
Lead length	0.4	m
Cable length	3.0	m
Operating range	-40 .. +125	Celsius deg
Protection	IP 57	-
Maximum allowable shock	3	G
Maximum allowable relative humidity	95	%

**3. Dimensional outline**

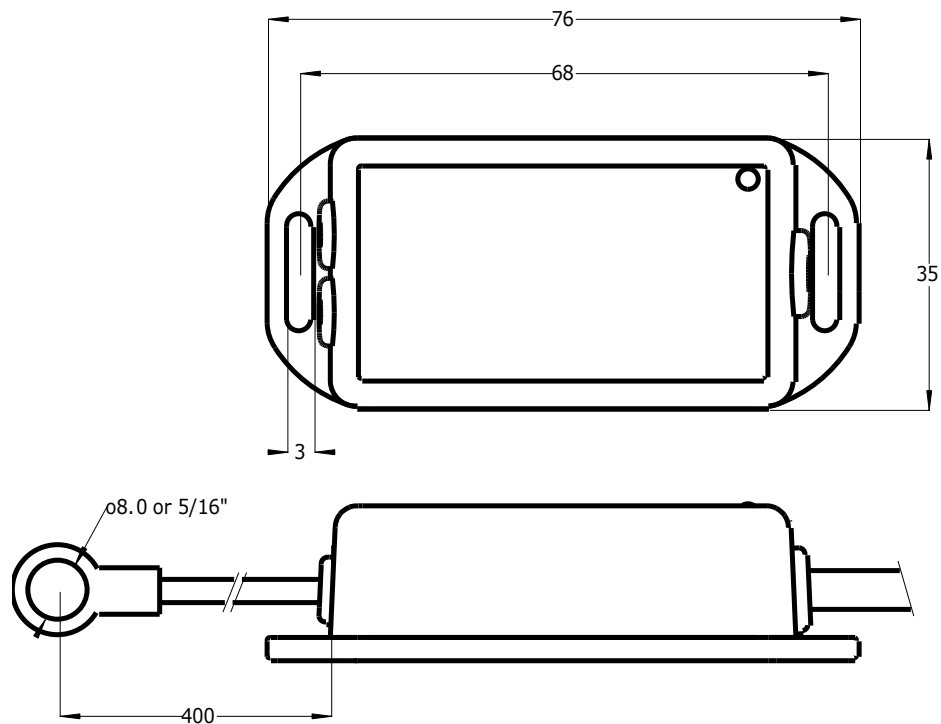

All units are millimeters

**3. Electrical specifications**

Parameter	Value	Units
DC voltage supply range	6 .. 20	Volts
Current consumption	0.020	Amps
LED color	Green	-
Cable ratings	Gauge: 20 AWG Material: tinned copper strands Strand size: Ø 0.16 mm Insulator Material: PVC Jacket Color: black Diameter: 5.5 mm	-
Communications format	RS-485	-
Wire colors designations	black – battery negative (isolated from the housing) red – DC positive supply (isolated from the housing) white – communication lead "A" yellow – communication lead "B"	-
Connector pin-out	1 - black – battery negative 2 - red – DC positive supply 3 - white – communication lead "A" 4 - yellow – communication lead "B"	-

4-pin connector pins, view from the cable side

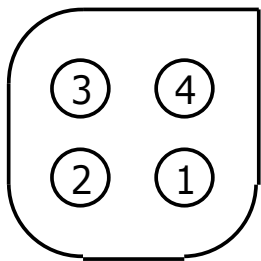

**Notice**

ElectroMaax reserves the right to make product modifications or discontinue products without notice. Customers are advised to obtain latest written specifications prior to ordering products. Information provided by ElectroMaax is believed to be accurate at the time of its release. Products sales are subject to the ElectroMaax Terms of Sales in force at the time of order acknowledgment. ElectroMaax products are not designed, authorized, or warranted for use in life support devices and systems, or any other critical applications which may involve death, injury, property or environmental damages. Using ElectroMaax products for any critical application is fully at the risk of the customers and their end users and assigns.

Canada:  
5552 King Street, Beamsville, Ontario, L0R 1B3  
Phone: 905-945-8800  
Fax: 905-563-8806

USA:  
2045 Niagara Falls Blvd, Niagara Falls, NY, 14304  
Phone: 1-866-945-8801