

Automatic

LPE 500 & LPE 700 LOW PROFILE ELECTRIC STATIONARY ROLLER MILL



Operator, Parts & Installation Manual

Introduction

Congratulations! You are now the owner/operator of America's finest roller mill. Please take a few minutes to be sure that you understand the maintenance and operation of this roller mill. Read this operator's manual carefully: you'll get better results and have fewer problems.

After your roller mill has been in operation for a few hours, check for loose bolts, setscrews, belts, etc. All are tight when the roller mill leaves the factory; however, after a break-in period, some items may require additional tightening. Like any other machine, your Automatic roller mill requires proper care and intelligence in operation. Misuse and neglect will only cause unnecessary expense and dissatisfaction.

This manual is written as a guide for owners and operators of the Automatic LPE500 & LPE700 model roller mill. Read it carefully and follow the suggestions made. Keep this manual in a convenient place for quick, easy reference, and use it whenever questions arise.

Fill in the following information now for future reference and convenience. Always give this information to your dealer when ordering new parts. If at any time it becomes necessary for you to write directly to Automatic Equipment Manufacturing Company for additional information, give the model and serial number of your machine, and as much descriptive information as possible. It will enable us to more thoroughly and quickly expedite your order.

Model No. _____ **Serial No.** _____ **Date of Purchase** _____

Name and Address of Dealer _____

Exchange & Resharpener Roll Service

If your rolls ever become dull or require resharpener, you can order an exchange set of rolls. For further details on our special roll replacement program, contact your nearest dealer or distributor. If you do not have a dealer or distributor in your area, contact the factory. Credit allowance on used rolls is subject to roll inspection upon return to factory via prepaid freight.

DEALER/OPERATOR PRE-USE INSPECTION CHECKLIST

Although everything is in working order when the roller mill leaves the factory, some components may get out of adjustment in transit. The following inspection must be made prior to operation. Check each item listed and make adjustments if necessary. Refer to the corresponding sections of the manual to determine the correct settings for individual items.

- Check all belts for proper tension and alignment.
- Check to make sure the set screws in all pulleys and bearings are tight.
- Check all grease line connections and lines for damage during shipment.
- Make a general check for bolts that may have vibrated loose during shipment.
- Check greased bearings for proper lubrication.
- Check to make sure all shields and guards are in place.
- After operating the roller mill for the first few times, go through this checklist again. Some bolts, setscrews and belts may require additional adjustment during this break-in period.

DO NOT OPERATE OR USE THIS EQUIPMENT UNTIL THE FOLLOWING OPERATING AND SAFETY INSTRUCTIONS HAVE BEEN READ AND UNDERSTOOD.

SAFETY



This symbol is used to bring attention to safety precautions and instructions. When you see this symbol, be alert and pay attention to all instructions. **YOUR PERSONAL SAFETY IS INVOLVED.**

The words **CAUTION**, **WARNING**, and **DANGER** following a  symbol indicate three degrees of hazard. **CAUTION** indicates a potentially hazardous situation which, if not avoided, may result in minor or moderate injury. It may also be used to alert against unsafe practices. **WARNING** indicates a potentially hazardous situation which, if not avoided, could result in **death** or serious injury. **DANGER** indicates an imminently hazardous situation which, if not avoided, will result in **death** or serious injury.

 **SAFETY PRECAUTIONS**

FAILURE TO UNDERSTAND AND PRACTICE GOOD SAFETY PROCEDURES COULD RESULT IN PERSONAL INJURY OR DEATH.

All farm machinery is inherently dangerous to children and to persons unfamiliar with its general operation. Children should not be permitted in areas where machinery of this nature is operating.

Since mills contain numerous moving parts, some of which may not always be visible to the operator, they can be extremely dangerous. Steps should be taken to assure the safety of the operator, and any other people in the area. Automatic Equipment strongly recommends that no person be permitted to operate this mill without a thorough understanding of how the machine works and the precautions to be observed.

If the mill discharges into an auger, be sure the auger is covered and shields are provided between the mill discharge and the auger.

Because of the dry, highly flammable material associated with this machine, **FIRE FIGHTING EQUIPMENT SHOULD BE READILY AVAILABLE DURING THE OPERATION OF THIS MACHINE.**

The operator of this machine should be a responsible adult who is familiar with farm machinery, and trained in its operation. **REMEMBER!** Your best insurance against accidents is a careful and responsible operator. A careless operator is a liability to himself and those who work with him.





Before operating this equipment, be sure to read and understand this operator's manual. If there is any portion of the manual, or any phase of the hammer mill's operation you do not understand, be sure to contact your local Automatic dealer or Automatic Equipment, Pender, Nebraska. 402-385-3051.

 **SAFETY PRECAUTIONS - BEFORE OPERATION**

- 1 Keep the mill in good repair. Good maintenance is your responsibility. A poorly maintained machine is an invitation for trouble. Always use proper tools when servicing your mill.
- 2 **DO NOT** start, operate, or attempt repair work on the mill until you carefully read and thoroughly understand this operator's manual.
- 3 Be sure all shields are in place and all bolts are tight throughout the mill.
- 4 Be sure the rolls and drive belts are properly adjusted and in good condition. (See Operation Section)
- 5 Be sure there are no tools or other foreign objects lying on or in the machine.

SAFETY

SAFETY PRECAUTIONS - DURING OPERATION

- 1 **DO NOT** wear loose-fitting clothing that may catch in moving parts.
- 2 Children should not be permitted in areas where machinery of this nature is operating.
- 3 **DO NOT** operate this machine until you are sure everyone is clear of the area.
- 4 **NEVER** leave the mill running unattended.
- 5 Always keep hands, feet, and clothing away from moving parts.
- 6  **DANGER** Keep hands and feet out of the hopper when machine is in operation. Never remove safety grates, or use your hands or feet to dislodge any obstruction from the mill. Never try to push or force feed grain or snow that may be bridged or laying in the hopper.
- 7 **NEVER** sit or stand on the mill while it is in operation.
- 8 **NEVER** adjust or service the unit while it is in operation.
- 9 **NEVER** open shields, mill access doors or clean out doors while the mill is in operation.
- 10  **DANGER** Avoid contact between the discharge auger and overhead electrical lines. Failure to heed warning will result in serious personal injury or death.
- 11 Hydraulic fluid can cause serious burns. Hydraulic fluid escaping under pressure can have enough force to penetrate the skin and may also infect a minor cut or opening in the skin. If injured by escaping fluid, see a doctor at once. Make sure all connections are tight and that hoses are in good condition.

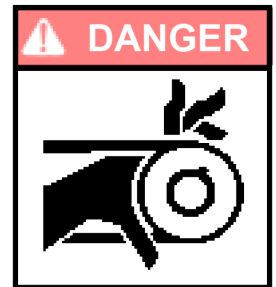

SAFETY PRECAUTIONS - SERVICE AND REPAIR

- 1 **SAFETY SHUTDOWN PROCEDURE:** Working on the mill when it is operating is expressly prohibited. Never clean, adjust, lubricate, or otherwise service this machine until the following steps have been taken.
 - A. Disengage the power source.
 - B. Lock all switches.
 - C. Wait until all mechanical motion has stopped on the mill.Only when these precautions have been taken, should you proceed in the adjustment or servicing of the mill. Failure to follow the above procedure could lead to death or serious personal injury.
- 2 Keep the mill in good repair. Good maintenance is your responsibility. A poorly maintained machine is an invitation for trouble. Always use proper tools when servicing machine, making certain that they are removed from the unit when services or repairs have been completed.
- 3 All mills are equipped with shielding to protect the operator from injury. **For purposes of clarity only**, some illustrations in this manual may show the mill with the shields removed or missing. Although shields may be opened or removed for servicing and repair of the mill, they **MUST** always be closed or replaced before operation resumes.

SET UP - Be sure the roller mill is mounted on a firm base with adequate room for proper servicing. The roller mill should be level while operating to allow the grain to flow evenly across the rolls. An even flow of grain will produce a more consistent product and helps to eliminate unnecessary strain on roll bearings and shafts. Electric powered units should be operated at about **780 RPM** (drive roll). Use a pulley ratio of 2.3 to 1 on 1800 RPM motors.

⚠ CAUTION: Before attempting to operate this roller mill, review and comply with all Safety Precautions listed in the SAFETY portion of this manual.

⚠ CAUTION: Always check to make sure everyone is clear of the roller mill before engaging power.

STARTING MILL - Your roller mill will not start properly if grain is present between the rolls. Always start the roller mill with the hopper gate in the hopper completely closed. (See Figure 2) After bringing the rolls up to full operating speed (780 RPM), open the hopper gate to allow grain to the rolls. If grain is released to the rolls before they are turning, it may bridge up and cause the mill to stop. If this happens, shut the hopper gate, shut down the roller mill and spread apart the rolls to allow the excess grain to pass through before restarting the mill. (See safety shut down procedure (Page 2) and roll adjustment (Below).

YOUR ROLLER MILL IS DESIGNED TO ELIMINATE COMPLICATED ADJUSTMENTS. Only two major points of adjustment exist for any small grain or shelled corn. HOPPER GATE CONTROL and ROLL SPACING.

HOPPER GATE CONTROL - Open the hopper gate gradually until you reach the maximum flow of grain that power will handle. If it becomes necessary to stop the machine at any time before the hopper is empty, be sure to close the hopper gate before disengaging power. **DON'T OVERCROWD ROLLS.** Keep a ribbon of grain feeding between the rolls and you'll do a more consistent job of rolling. This is especially true of oats and barley. It is not necessary to completely flatten the kernel of any grain being rolled. Grain is easier to digest when the hard coat or hull is broken open or cracked, exposing their nutrients to the digestive juices of livestock.

ROLL SPACING depend upon the type of grain to be rolled and roll corrugation. Grain varies in size, shape, toughness and moisture content. This is also true of the same type of grain from different localities. For these reasons, it is impossible to say exactly where to set the rolls. The roll spacing is factory set at approximately 0.015", placing the rolls as close together as possible. Do not over-roll hard or dry grains, as this will cause dusting. Remember, proper adjustment keeps dust at a minimum, even when rolling the driest grain.

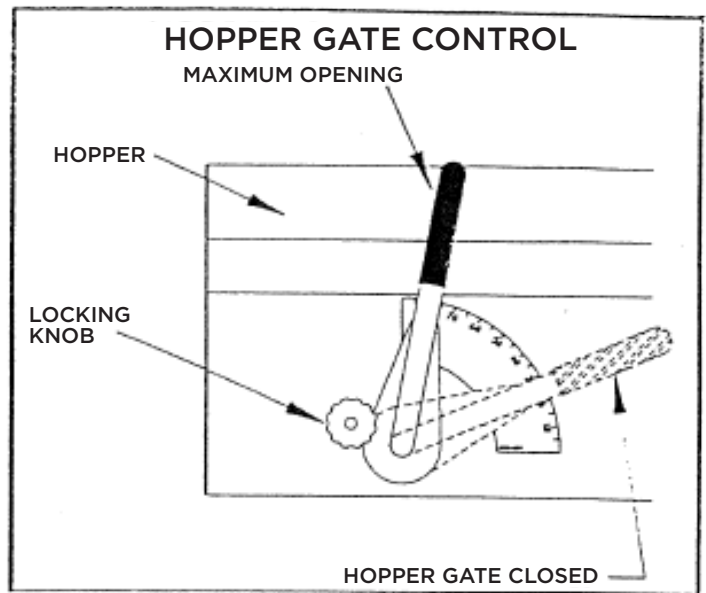
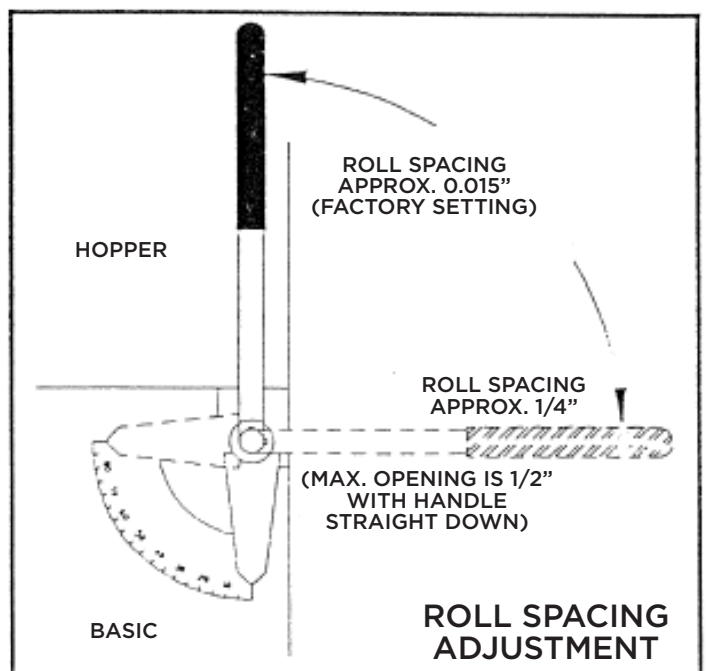

Figure 2

ADJUSTING ROLLS - (See Figure 3) When the roll adjust handle is straight up, the rolls are at their closest setting, producing the finest, or smallest, particle size possible with the current roll corrugation. To increase the roll spacing and particle size, loosen the locking handle on the motor side of the mill (See Figure 1) and rotate the roll adjust handle clockwise. A wider roll spacing is achieved with the roll adjust handle in the horizontal position. The curved decal by the indicator pointer of the roll adjust handle should be used by the operator as a reference to note frequently used roll spacing for different rolling applications. It is not intended for specific roll spacings. **IMPORTANT:** Remember to tighten the locking handle before resuming any rolling operations. **IMPORTANT: NEVER OPERATE THE MILL WITH THE ROLLS TOUCHING!**



SETUP / OPERATION

BELT TENSIONING AND ALIGNMENT

To properly tighten the drive belt you should first open the rolls to a gap of approximately 1/4 inch. This is done by rotating the roll spacing adjustment handle clockwise until it is 90° from vertical.

Tighten the drive belt. The tension should be measured between the motor and flat pulley. The belt should deflect 3/16" using approximately 60 pounds of force.

Reset the roll gap spacing as instructed on page 6 of the LPE manual.

Periodic checks of all belts should be made to ensure proper alignment, correct tension levels, and detect worn or deteriorating belts.

To check belt alignment, lay a long straight edge along the cog belt sprockets. The outside edge of all three should line up, including the motor sprocket.

SHUT DOWN PROCEDURE

During normal operation of this mill, the following shut down procedure should always be followed to ensure that the rolls are free from excess grain build up that may prevent the mill from starting up properly.

- 1 When shutting down your mill, always stop the flow of grain into the hopper first.
- 2 When all grain has passed through the rolls and the hopper is empty, the hopper gate control should be closed. (rotated clockwise)
- 3 Finally, disengage the electrical power to the roller mill.

The following are instructional diagram on how to wire the power disconnect box which is located on the roller mill hopper, just above the electric motor. Below is a diagram covering single phase electricity. The maximum power which a particular box can handle will be displayed on the box, but should be 60 amps and 220-240 volts, single or 3 phase.

If you have any questions on these instructions or how to wire up the disconnect box, please contact your local dealership which sold you the mill.

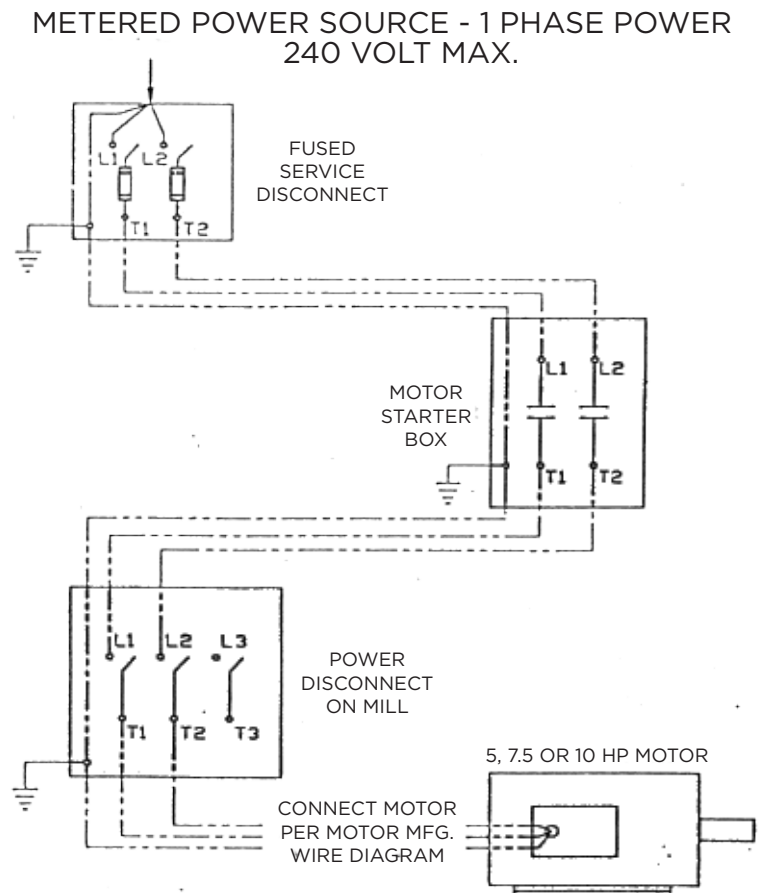

LUBRICATION / SPECIFICATIONS

LUBRICATION -  DANGER: Do not attempt to lubricate, adjust or service the roller mill while it is in operation.

BEARINGS - All pillow block bearings are sealed and as a general rule, REQUIRE NO LUBRICATION. However, the bearing manufacturer does furnish grease zerks and recommends that the bearings be greased before 1/3 of the bearing's calculated life elapses. Usually a pump or two of grease every 100 hours of operation will be sufficient. IMPORTANT: DO NOT OVERGREASE! Overgreasing can cause damage to the bearing seal. Each time the bearings are greased, be sure to check the condition of the grease lines on the drive side of the mill.

GEARBOX (Discharge Auger Option) - The gearbox is filled at the factory, but the oil level should be checked initially, and periodically thereafter. It is very important to keep the gearbox from running dry. There will be a slight leakage around the seals so expect to add grease from time to time. Automatic recommends SAE 80 W-90 multipurpose gear lubricant.

SPECIFICATIONS

Model	LPE 500	LPE 700
Roll Corrugation (Teeth Per Inch).....	4, 6 1/2, 8, 10, or 14.....	4, 6 1/2, 8, 10, or 14
Roll Size	9" Dia. x 10" Long.....	9" Dia. x 14" Long
Power Requirements		
Minimum Horsepower.....	5.....	7.5
Maximum Horsepower.....	7.5.....	10
Overall Height (With Legs*).....	39"	39"
Overall Height (Without Legs*).....	24"	24"
Overall Height (Without Legs*) (With Auger Base*)....	31 1/2"	31 1/2"
Overall Length.....	43 1/2"	43 1/2"
Overall Width.....	28"	32"
*Discharge Auger (Diameter).....	8"	8"
Length.....	5' or 10'	5' or 10'
Drive	Belt.....	Belt

*OPTIONS:
 Auger Base
 Leg Pack
 Discharge Auger

OPERATION / MAINTENANCE

OPTIONAL ROLL CONFIGURATION - This roller mill is available with five different roll configurations and comes standard with a differential drive (See Figure 4). Corrugation numbers refer to the number of corrugations or “teeth” per inch. The larger the corrugation number, the smaller the particle size produced. Changing the roll gap is the next preferred method for adjusting particle size. (See Adjusting Rolls section, page 6) In addition, feed consistency, or particle size, may be adjusted by changing the relative drive roll and idler speeds. This is accomplished by replacing the drive roll pulley with a pulley the same size as that of the idler roll. (See Figure 5). However, when the drive method is changed, it will generally reduce the capacity of the mill and not allow as fine a particle size. Consult your dealer, or Automatic Equipment for recommendations regarding roll configuration by any other method than those approved by Automatic Equipment will void the warranty.

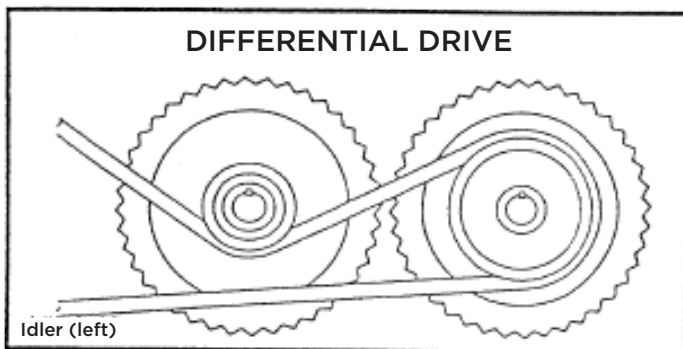

Figure 4

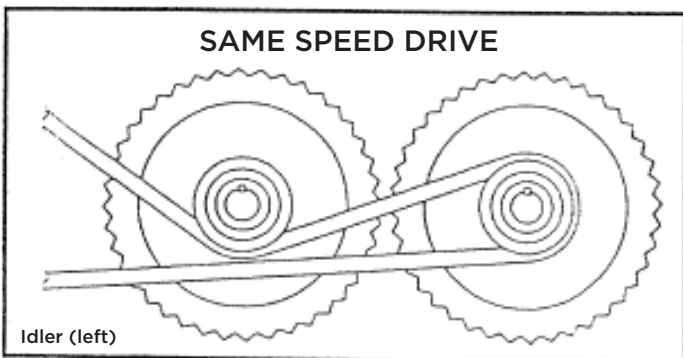

Figure 5

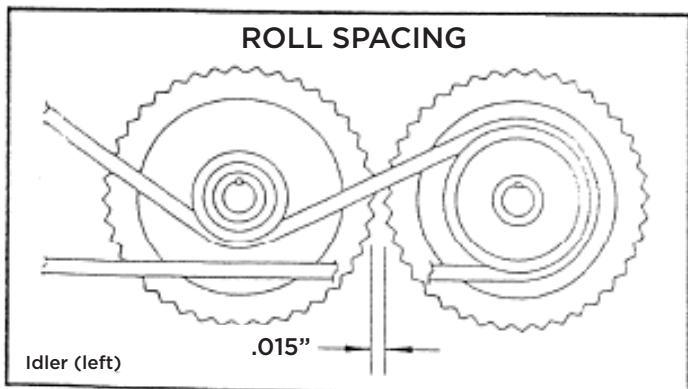

Figure 6

MAINTENANCE - Automatic roller mills are manufactured from the best materials and workmanship available. Simple adjustments and minimum maintenance have been emphasized in their engineering. Although all components of your roller mill are tested and properly adjusted before it leaves the factory, some may require additional adjustment after a break in period.

After your roller mill has been in operation for a few hours, examine the entire machine for loose bolts, set screws, lock collars, belts, etc. This initial check is an important first step in an ongoing program for keeping your roller mill in top running condition and should be performed periodically as part of the general maintenance of your roller mill. Like any other implement, your roller mill requires proper care and intelligence in operation. Misuse and/or neglect will only cause unnecessary expense and dissatisfaction.

⚠ WARNING: SHIELDS AND GUARDS ARE PROVIDED FOR YOUR PROTECTION. Although some shields and guards may need to be removed or opened for servicing and adjustments, they should always be replaced or closed before operation resumes.

BELTS - All belts should be inspected for proper alignment and tension after a few hours of operation. Tension should be measured between the motor and flat pulley. The belt should deflect 3/16" using approximately 60 pounds of force. Periodic checks of all belts should be made to ensure proper alignment, correct tension levels and to detect worn or deteriorating belts.

PULLEY SET SCREW ADJUSTMENT - The belt drive system on your roller mill includes several pulleys which use a setscrew to hold them in place on the key. ONLY "Cup Point" set screws with knurled tips should be used. To correctly seat the set screw, turn it "IN" and "OUT" several times before tightening in place. This will wear a groove in the key for the setscrew to seat in.

ROLLER TENSION SPRINGS - The roller tension springs on the idler roll are set at the factory to maintain the correct amount of pressure. They should be 4 1/2" long $\pm 1/8$ ". The springs allow the rolls to separate so foreign objects such as nails, bolts, stones, gravel, etc. may pass between the rolls. A magnetic grate is standard on the roller mill and should remove most of the metal items, but in the event that something gets through, the spring action will help prevent the roll teeth from being damaged. If the rolls become out of alignment and require readjustment, the springs may require similar adjustments. (See Realigning Rolls, Page 8)

REALIGNING ROLLS

REALIGNING ROLLS - If the rolls ever become out of alignment (more gap on one end of the roll pair than the other) they must be realigned to maintain feed consistency and prolong the life of the rolls. To accomplish this, follow the instructions below.



DANGER: Before attempting to service your roller mill be sure to follow the SAFETY SHUTDOWN PROCEDURE on page 2.

1 Remove the drive belt from all the pulleys and lay it aside. Loosen the jam nut (item 10) on one of the sides of the mill. It may be necessary to loosen and adjust both sides to acquire the correct settings. This will be determined by how far out of parallel the rolls are.

2 Adjust the other nut (9) on the same side, until the rolls are parallel. To check for roll spacing, a strip of metal banding works well but any strip of metal approximately 1/32" thick will also work. Slide the strip between the rolls and verify the roll spacing is the same along their entire length. Check the spacing 3 or 4 times with the rolls at various rotated positions to assure the rolls are as close to parallel as possible. NOTE: Rolls will vary a few thousandths of an inch in diameter along their length, be sure to check for the tightest gap.

3 With the rolls parallel you can now set the roll spacing. Place the roll spacing adjustment handle straight up with the indicator straight down. This will set the rolls at their closest possible setting.



4 **WARNING:** Be careful not to get your hands between the rolls or between the rolls and the basic frame.



WARNING: Do not power the mill with the motor. This creates a personal danger to you and may cause damage to the rolls if they are touching.

5 By hand, spin the rolls in the same direction (clockwise) at different speeds. Strike the idler roll shaft at the bearing, towards the drive roll, with a rubber mallet to ensure that the idler bearing mount (6) is free to allow the rolls to be at their closest position. With the rolls spinning freely at different speeds, turn the nuts (9) on both sides of the mill out evenly until you hear the roll teeth touch. They will make a ticking sound that should be easily heard. This is to ensure that the rolls do not move closer together with the vibration of the mill. Some additional adjustment may be needed at this time.

6 Once the roll teeth touch, turn the nuts (9) IN about 1/4 to 1/2 flat on the nut. (See Figure 7).

NOTE: There are six flat sides on each nut. Turning one full flat means turning the nut so that the flats advance one position.

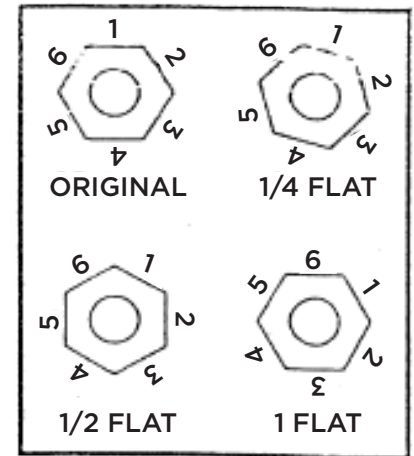

Figure 7

7 Hold the nuts (9) in place and tighten the jam nuts (10) on both sides of the mill. Recheck that the rolls do not touch by repeating step 5.

8 Move the roll spacing adjustment handle 5° each way from center and check to assure the rolls are not touching. Readjust if necessary. Be sure to tighten jam nuts (10) when finished.

9 If adjustments were made, measure the length of the springs (5). They should be 4 1/2" long $\pm 1/8$ ". If spring adjustment is needed, loosen the jam nut (2) on the spring side and move spring nut (3) until the correct spring length is established. Once adjusted, tighten the jam nut (2) to hold setting.

10 Make a final check of the rolls for parallel and roll gap. You may need to use a feeler gauge for 8 cut and finer rolls. Reinstall the drive belt and shields. Be sure to remove any tools from the machine before restarting.

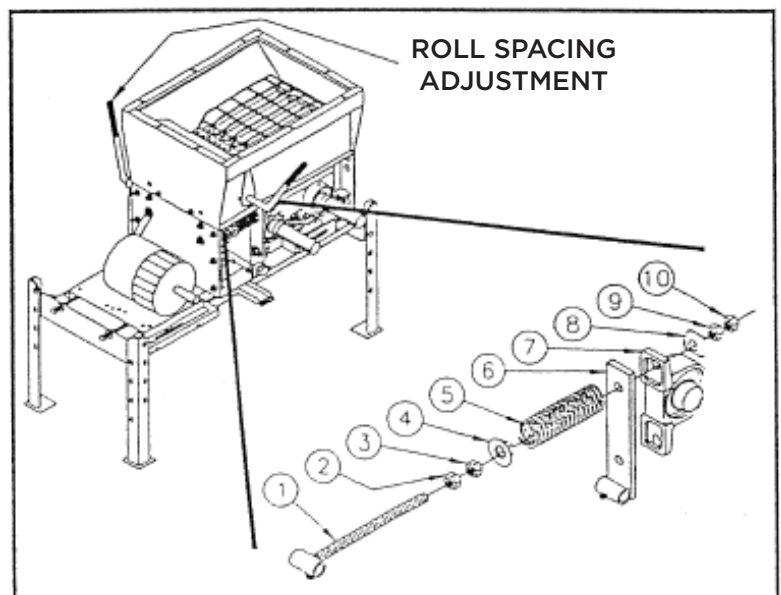

Figure 8

REPLACEMENT PARTS

REPLACEMENT PARTS

DRIVE ASSEMBLY.....	11
BASIC	12-13
HOPPER ASSEMBLY	14-15
PRIMARY ASSEMBLY	16-17
BELT DRIVE SHIELDS	18
AUGER BASE (option).....	19
DISCHARGE AUGER (option)	20-21

When ordering parts for your roller mill, please state your needs with the following information:

COMPLETE MODEL NO.	COMPLETE SERIAL NO.	PART NO.	DESCRIPTION
LPE500X8	000000	61-3967	Weldment, Idler Bearing Mount

When you order in this way, you can be certain the correct part will be delivered in the shortest time possible.

IMPORTANT: Use only genuine factory replacement parts on your roller mill. Do not substitute homemade or non-typical parts. If a bolt is lost or in need of replacement, for your safety and the preservation of your roller mill, be sure to use a replacement bolt of the same grade (Usually Grade 5).

Repair parts may be ordered through your nearest Automatic dealer. If there is no dealer in your area, write or call Automatic Equipment Mfg. Co., Pender, Nebraska 68047, phone (402) 385- 3051.

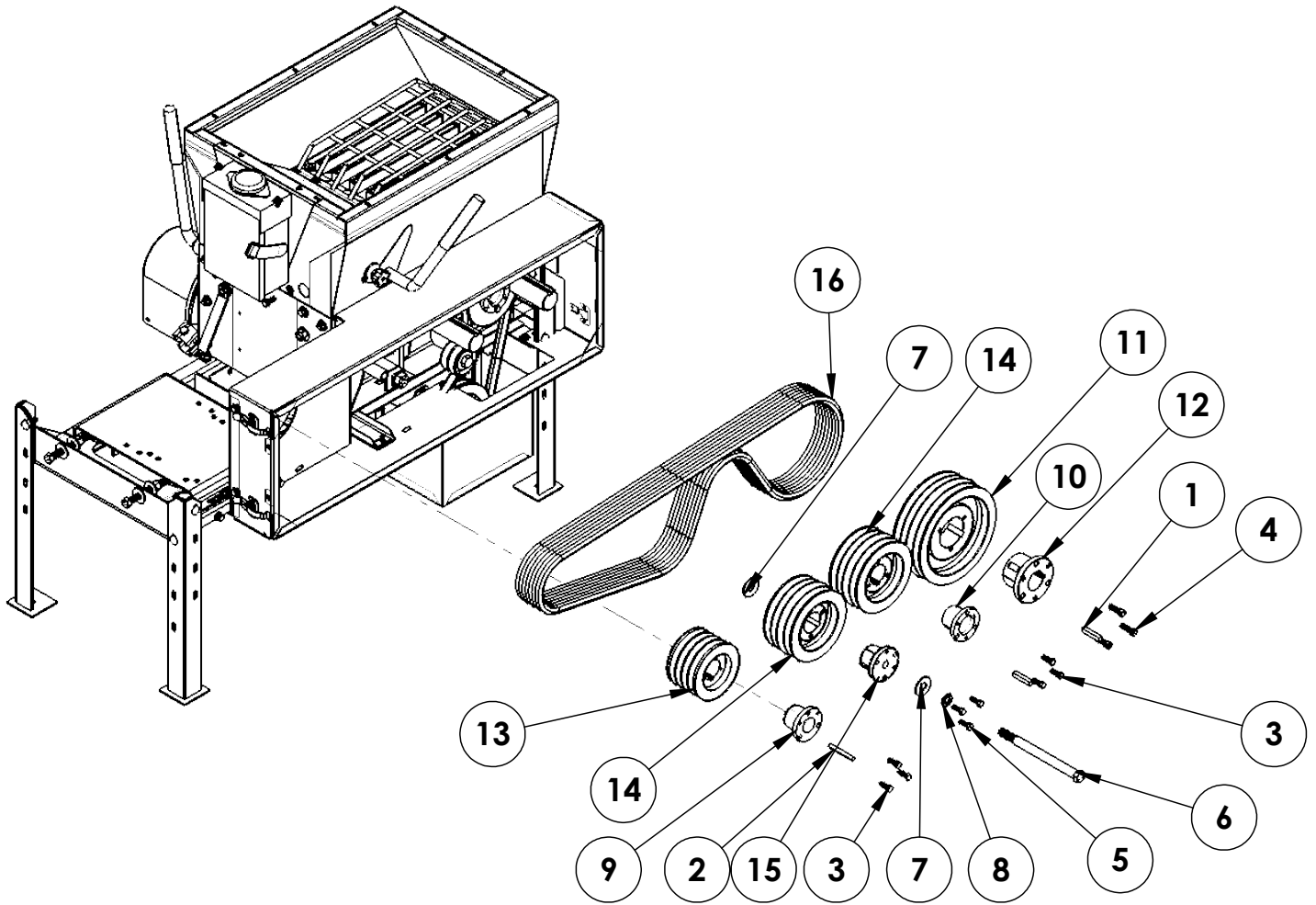

Item No.	Part No.	Description	Qty.
1.....	100-0224	3/8" x 3/8" x 2" Key	2
2.....	100-0304	5/16" x 5/16" x 2-3/4" Key	1
3.....	201-0120	5/16"-18 x 1" Hex Head Bolt, Grade 5, ZP	6
4.....	201-0368	3/8"-16 x 1-1/4" Hex Head Bolt, Grade 5, ZP	3
5.....	201-0469	5/16" -18 x 1" Hex Head Bolt, Grade 5, ZP	3
6.....	201-1107	5/8"-11 x 9" Hex Head Bolt, ZP.....	1
7.....	203-0006	5/8" Flat Washer, ZP.....	2
8.....	203-0013	5/8" Lock Washer, ZP.....	1
9.....	203-0052	P1 - 1-3/8" Bushing	1
10.....	203-0054	P1 - 1-3/4" Bushing	1
11.....	205-0209	4TB86 Browning Sheave.....	1
12.....	205-0221	Q1 - 1-3/4" Browning Bushing	1
13.....	205-0292	4TB48 Browning Bushing.....	1
14.....	205-0307	4TB62 Browning Bushing.....	2
15.....	205-0414	P1-BB x 5/8" Bushing	1
16.....	251-0083	BB85 Belt-V.....	4

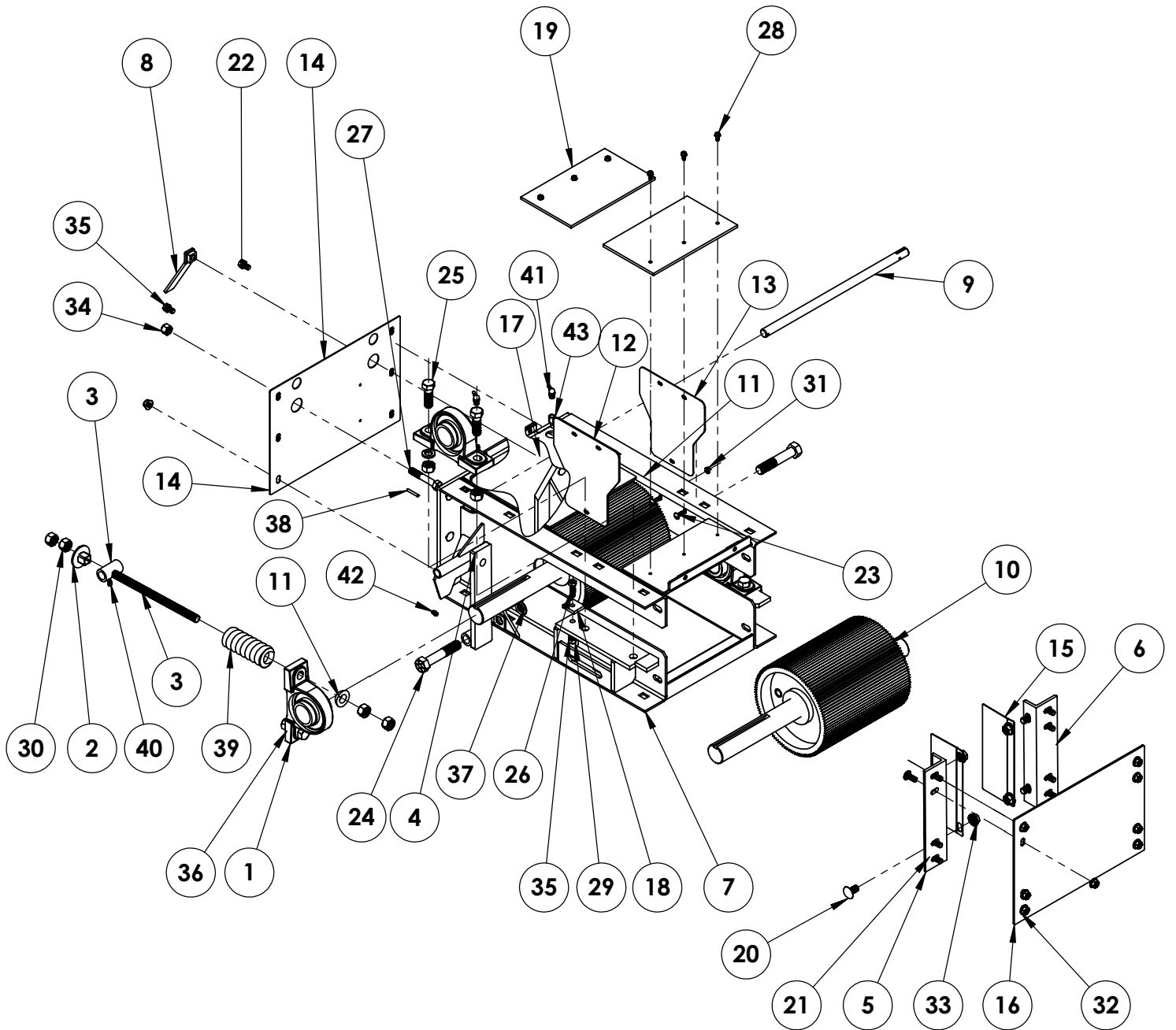

Item No.	Part No.	Description	Qty.
1	53-0005	1-3/4" Pillow Block Bearing	4
2	61-1968	Spring Center	2
3	61-3966	Take Up Rod, LPE	2
4	61-3967	Idler Bearing Mount, LPE	2
5	61-3968	Drive Bearing Stop, LPE	1
6	61-3969	Idler Bearing Stop, LPE	1
7	61-3984	LPE500 Basic	1
	61-4009	LPE700 Basic	1
8	61-4018	Cam Locking Handle, LPE	1
9	61-4025	LPE500 Cam Adjustment Rod	1
	61-4004	LPE700 Cam Adjustment Rod	1
10	71-0450	LPE500 Roll, 4 Cut	2
	71-0451	LPE500 Roll, 6.5 Cut	2
	71-0452	LPE500 Roll, 8 Cut	2
	71-0453	LPE500 Roll, 10 Cut	2
	71-0454	LPE500 Roll, 12 Cut	2
	71-0455	LPE500 Roll, 14 Cut	2
	71-0457	LPE700 Roll, 4 Cut	2
	71-0458	LPE700 Roll, 6.5 Cut	2
	71-0459	LPE700 Roll, 8 Cut	2
	71-0460	LPE700 Roll, 10 Cut	2
	71-0461	LPE700 Roll, 12 Cut	2
	71-0462	LPE700 Roll, 14 Cut	2
11	100-1268	Cam Adjustment Rocker, LPE	2
12	101-4962	10 GA Roll Wear Plate, LPE	1
13	101-4963	14 GA Roll Wear Plate, LPE	1
14	101-4982	LPE500 Cam Side End Plate	1
	101-5044	LPE700 Cam Side End Plate	1
15	101-4993	Drive Roll Cover, LPE	2
16	101-4994	LPE500 Drive Roll Side End Plate	1
	101-5049	LPE700 Drive Roll Side End Plate	1
17	102-4003	Cam Adjustment Pivot, LPE	2
18	102-4006	Flat Bearing Stop, Bolt On, LPE	2
19	150-0028	LPE500 Rubber Baffles	2
	150-0037	LPE700 Rubber Baffles	2
20	201-0024	1/2"-13 x 1" Carriage Bolt, Grade 5	4
21	201-0034	3/8"-16 x 1" Carriage Bolt, Grade 5, ZP	14
22	201-0081	3/8"-16 x 3/4" Hex Head Bolt, Grade 2, ZP	2
23	201-0111	1/4"-20 x 3/4" Slot Truss Head Screw	6
24	201-0346	3/4"-10 x 4" Hex Head Bolt, Grade 8, ZP	2
25	201-0351	5/8"-11 x 2" Hex Head Bolt, Grade 5, ZP	6
26	201-0368	3/8"-16 x 1-1/4" Hex Head Bolt, Grade 5, ZP	2
27	201-0490	1/2"-13 x 3" Hex Head Bolt, Grade 5, ZP	2
28	201-0553	1/4"-20 x 1/2" Hex Washed Type F TCS, ZP	6
29	202-0003	3/8"-16 Hex Nut, ZP	2
30	202-0006	5/8"-11 Hex nut	14
31	202-0069	1/4"-20 Hex Flange Whiz Lock Nut, ZP	6
32	202-0071	3/8"-16 Whiz Flange Lock Nut, ZP	14
33	202-0072	1/2"-13 Hex Flange Whiz Lock Nut, ZP	4
34	202-0094	1/2"-13 Hex Nylon Insert Lock Nut, ZP	1
35	203-0010	3/8" Lock Washer, ZP	4
36	203-0013	5/8" Lock Washer, ZP	6
37	203-0066	18 GA x 1-1/4" x 3/4" Machine Bushing	8
38	220-0032	3/16" x 1-1/4" Sping Pin, ZP	2
39	222-0078	Comp Spring	2
40	224-0327	1/4"-28 Grease Zerk	2
41	224-0375	1/8" NPT x 45 Degree Grease Zerk	2
42	224-0425	1/4"-28 Self-Tap Straight Zerk	2
43	224-0469	1/4"-28 Male to NPT Female Set-Up	2

HOPPER ASSEMBLY

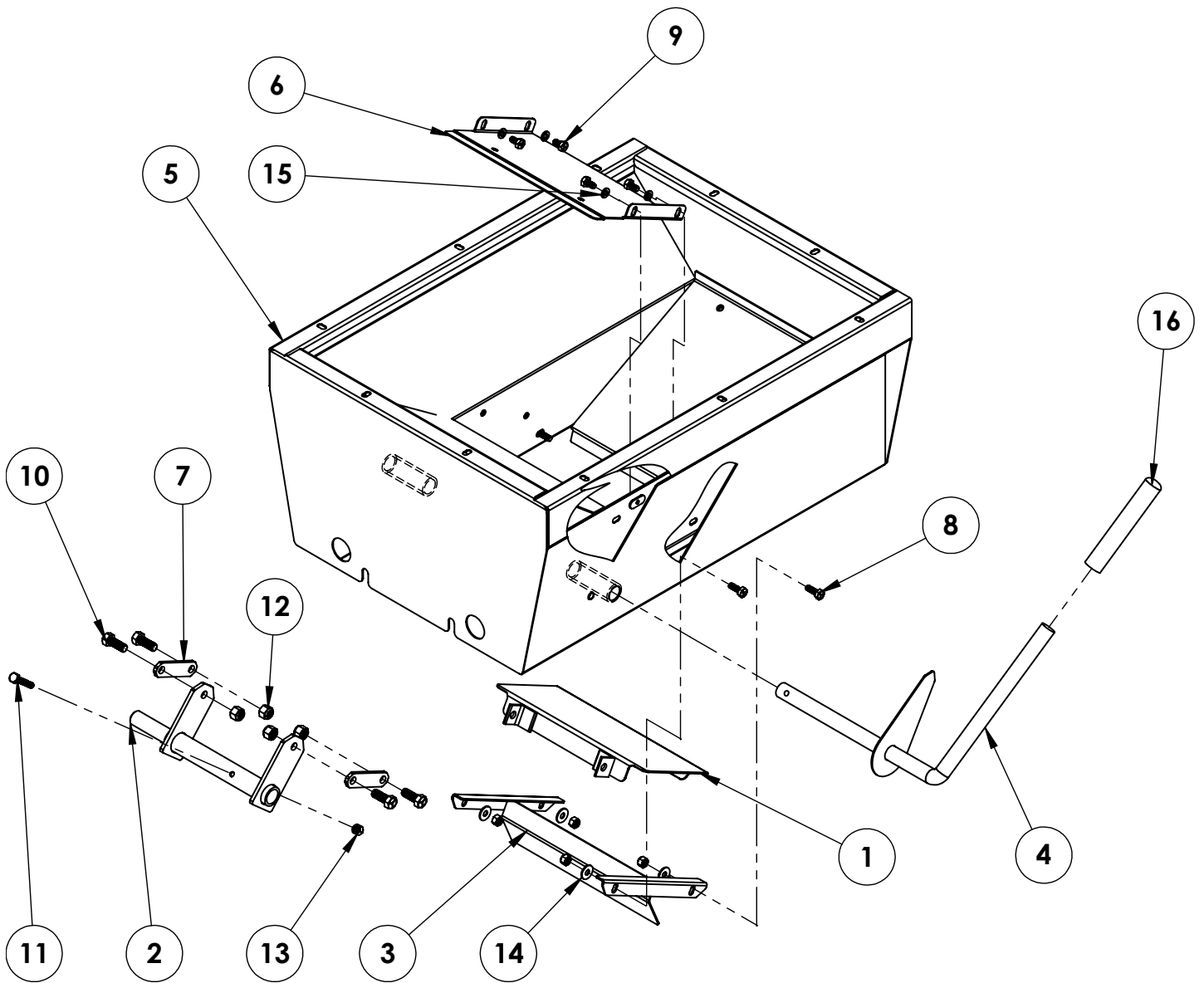

HOPPER ASSEMBLY

Item No.	Part No.	Description	Qty.
1.....	61-3951	LPE500 Slide Gate	1
	61-4000	LPE700 Slide Gate	1
2.....	61-3952	LPE500 Gate Rod	1
	61-4001	LPE700 Gate Rod	1
3.....	61-3953	LPE500 Gate Holder	1
	61-4013	LPE700 Gate Holder	1
4.....	61-3954	Gate Handle	1
5.....	61-3955	LPE500 Hopper	1
	61-4002	LPE700 Hopper	1
6.....	61-3956	LPE500 Gate Slope.....	1
	61-4003	LPE700 Gate Slope.....	1
7.....	102-3996	Bolted Link Arm	2
8.....	201-0050	1/4"-20 x 3/4" Hex Head Bolt, Grade 5, ZP	4
9.....	201-0193	1/4"-20 x 1/2" Hex Head Bolt, Grade 5, ZP	4
10.....	201-0443	3/8"-16 x 1" Hex Head Bolt, Grade 5, ZP	4
11.....	201-0448	1/4"-20 x 1-1/2" Hex Head Bolt, Grade 5, ZP	1
12.....	202-0090	3/8"-16 Hex Nylon Insert Lock Nut, ZP.....	4
13.....	202-0102	1/4"-20 Hex Nylon Nut, ZP	5
14.....	203-0001	1/4" Flat Washer, ZP.....	4
15.....	203-0008	1/4" Lock Washer, ZP	4
16.....	290-030075 Round x 5" Vinyl Handle.....	1

PRIMARY ASSEMBLY

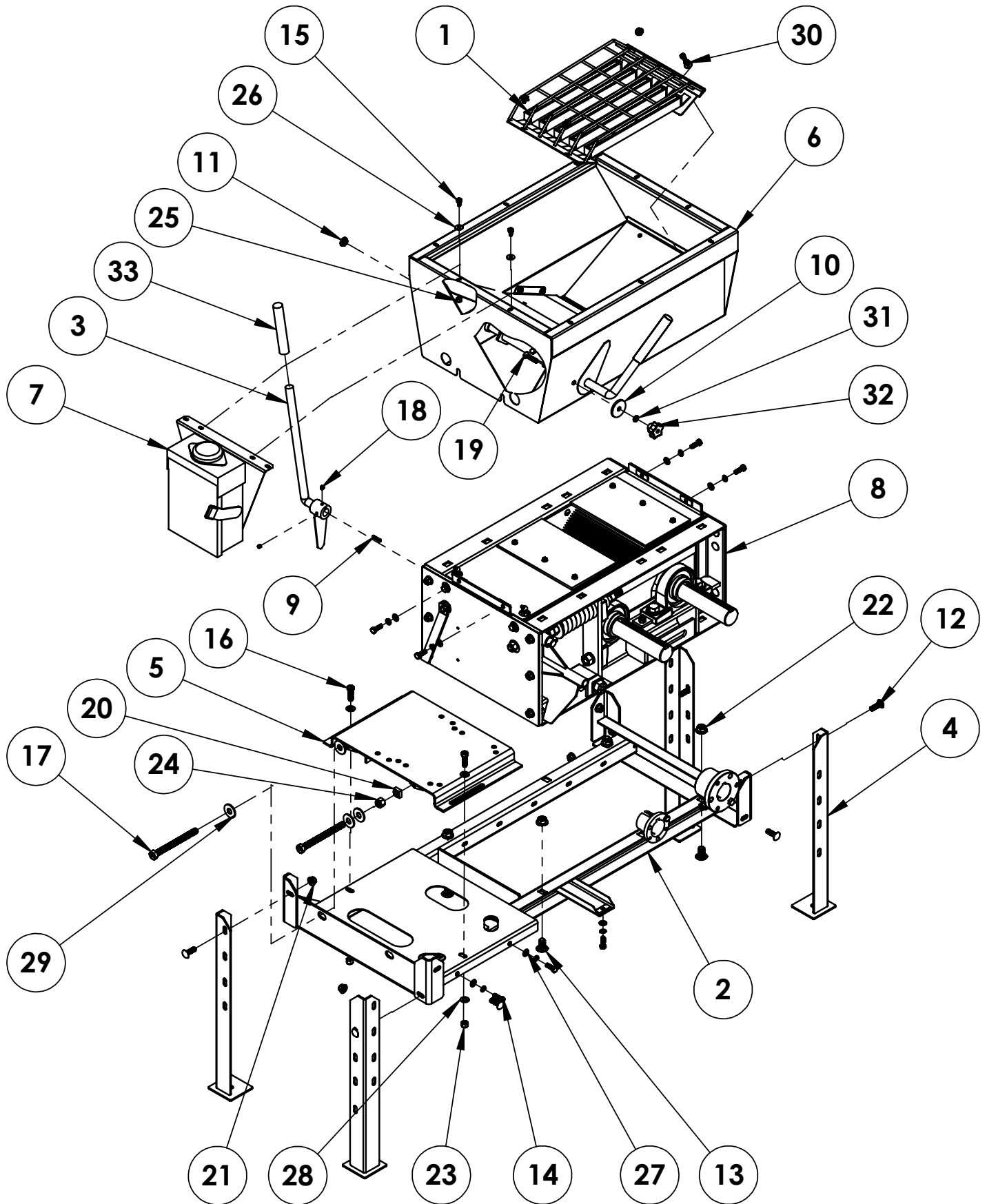

PRIMARY ASSEMBLY

Item No.	Part No.	Description	Qty.
1	61-3961	LPE500 Magnetic Grate	1
	61-4005	LPE700 Magnetic Grate	1
2	61-3964	LPE500 Frame	1
	61-4010	LPE700 Frame	1
3	61-3970	Cam Handle	1
4	61-3971	Leg	4
5	61-3972	LPE500 Motor Mounting Plate	1
	61-4011	LPE700 Motor Mounting Plate	1
6	62-3066	LPE500 hopper Assembly	1
	62-3089	LPE700 hopper Assembly	1
7	62-3207	LPE Disconnect Box Assembly	1
8	93-0527	LPE500 x 4 Basic Assembly	1
	93-0528	LPE500 x 6.5 Basic Assembly	1
	93-0529	LPE500 x 8 Basic Assembly	1
	93-0530	LPE500 x 10 Basic Assembly	1
	93-0531	LPE500 x 12 Basic Assembly	1
	93-0532	LPE500 x 14 Basic Assembly	1
	93-0534	LPE700 x 4 Basic Assembly	1
	93-0535	LPE700 x 6.5 Basic Assembly	1
	93-0536	LPE700 x 8 Basic Assembly	1
	93-0537	LPE700 x 10 Basic Assembly	1
	93-0538	LPE700 x 12 Basic Assembly	1
	93-0539	LPE700 x 14 Basic Assembly	1
9	100-0544	3/16" x 3/16" x 1" Key	1
10	101-3323	Idler Support, Third Rod Washer	1
11	200-1419	3/4" Hole Plug	1
12	201-0008	3/8"-16 x 1-1/4" Carriage Bolt, Grade 5	8
13	201-0024	1/2"-13 x 1" Carriage Bolt, Grade 5	4
14	201-0120	5/16"-18 x 1" Hex Head Bolt, Grade 5, ZP	8
15	201-0193	1/4"-20 x 1/2" Hex Head Bolt, Grade 5, ZP	6
16	201-0368	3/8"-16 x 1-1/4" Hex Head Bolt, Grade 5	2
17	201-0377	1/2"-13 x 5-1/2" Hex Head, Grade 5, FT	2
18	201-0527	1/4"-28 x 5/16" Set Screw	2
19	201-0537	5/16"-18 x x1-1/2" Bolt Flsckt Head, FT	1
20	202-0012	1/2-13 Square Nut Plate (Not Plated)	2
21	202-0071	3/8"-16 Whiz Flange Lock Nut, ZP	8
22	202-0072	1/2"-13 Hex Flange Whiz Lock Nut, ZP	4
23	202-0090	3/8"-16 Hex Nylon Insert Lock Nut, ZP	2
24	202-0094	1/2"-13Hex Nylon Insert Lock Nut, ZP	2
25	202-0102	1/4"-20 Hex Nylon Nut, ZP	2
26	203-0001	1/4" Flat Washer, ZP	6
27	203-0002	5/16" Flat Washer, ZP	7
28	203-0003	3/8" Flat Washer, ZP	4
29	203-0005	1/2" Flat Washer	4
30	203-0008	1/4" Lock Washer, ZP	4
31	203-0009	5/16 Lock Washer	8
32	290-0023	5/16"-18 Plastic Knob	1
33	290-0300	75 Round x 5" Vinyl Handle	2

BELT DRIVE SHIELDS

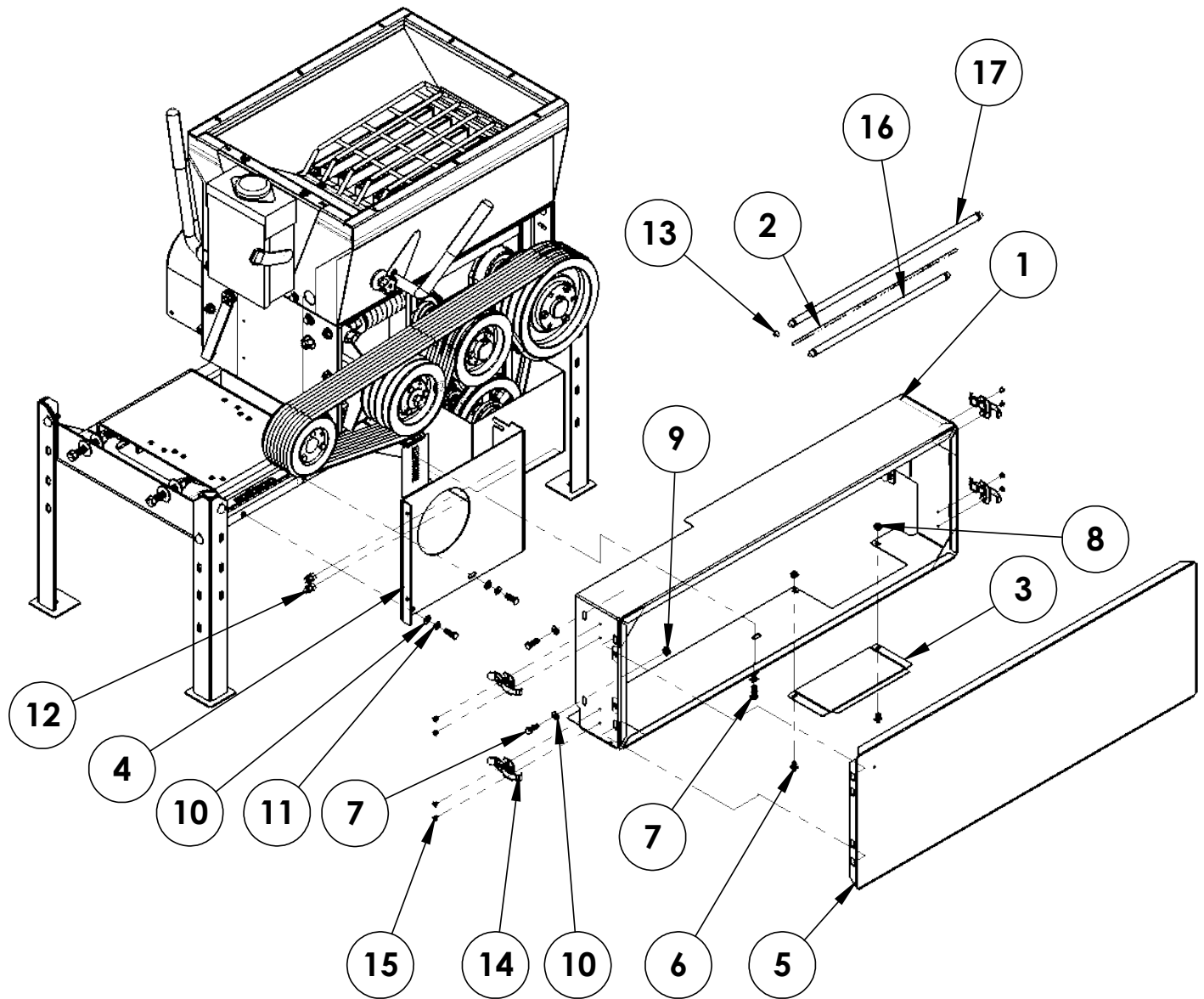

Item No.	Part No.	Description	Qty.
1.....	61-3977	Shroud	1
2.....	100-0899	Shield Tether Cable	1
3.....	101-2532	Belt Shield Filler	1
4.....	101-4986	Motor Hole Shield	1
5.....	101-5011	Drive Pulleys Shield	1
6.....	201-0112	1/4"-20 x 1/2" Slot Truss Head Screw	2
7.....	201-0120	5/16"-18 x 1" Hex Head Bolt, Grade 5, ZP	9
8.....	202-0069	1/4"-20 Hex Flange Whiz Lock Nut, ZP	2
9.....	202-0070	5/16"-18 Hex Flange Whiz Lock Nut, ZP	2
10.....	203-0002	5/16" Flat Washer, ZP	9
11.....	203-0009	5/16" Lock Washer	8
12.....	224-0468	1/8" Female NPT Grease Zerk	2
13.....	225-0049	3/32" Cable Swaging Sleeve	1
14.....	229-0132	Tension Latch	4
15.....	229-0988	3/16" x 1/16"-1/8 SB6-2 Pop Rivet	8
16.....	253-0184	1/8" x 16" Grease Line	1
17.....	253-0261	1/2" x 22" Grease Line	1

AUGER BASE (Option)

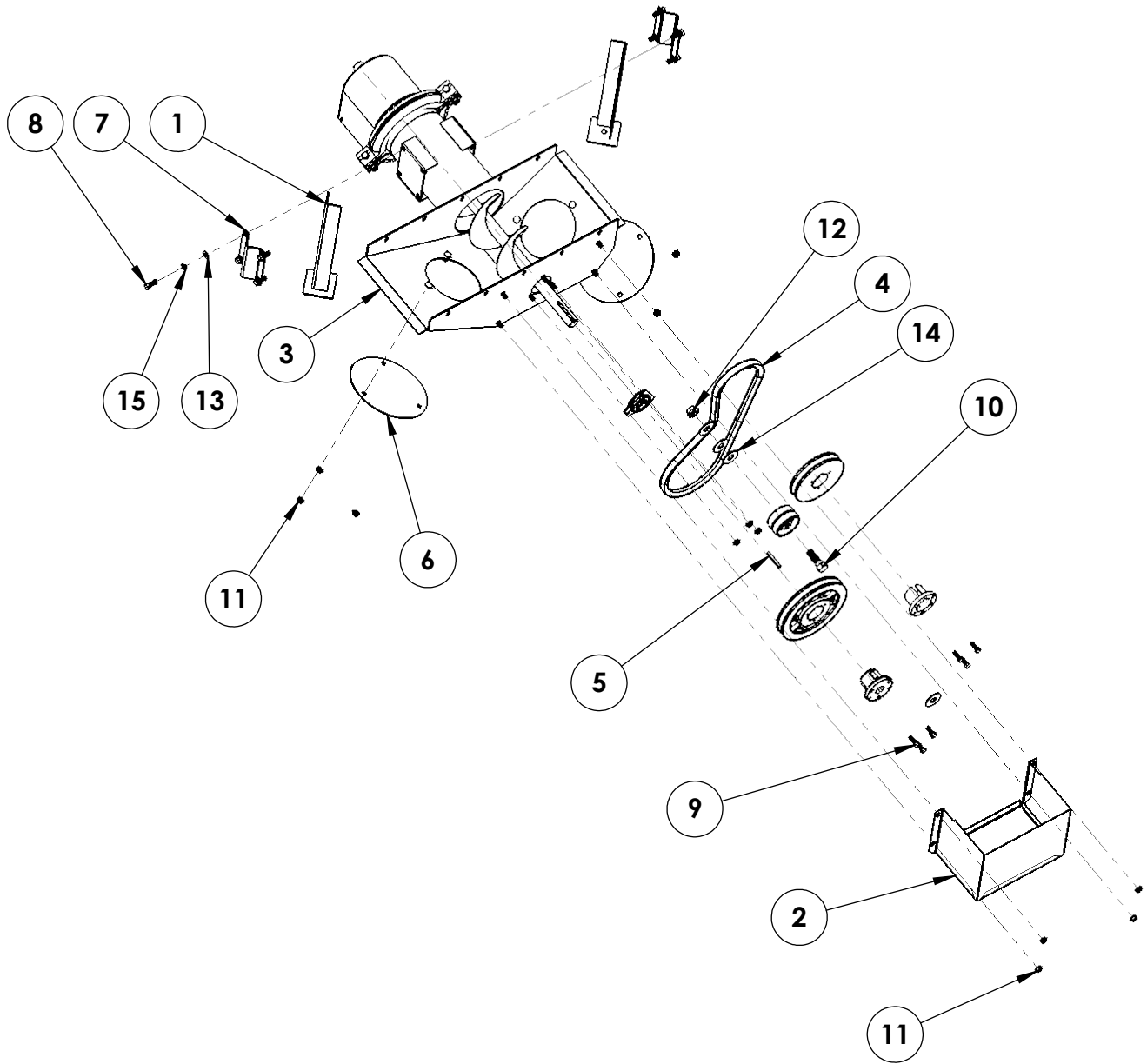

Item No.	Part No.	Description	Qty.
1.....	61-3975.....	Auger Base Leg.....	2
2.....	61-3976.....	Auger Base Shield.....	1
3.....	62-3067.....	LPE500 Auger Base Pack.....	1
4.....	63-1314.....	Auger Base B & P Pack.....	1
5.....	100-0545.....	1/4" X 1/4" x 2" Key.....	1
6.....	101-2306.....	Clean Out Door Cover.....	2
7.....	101-5010.....	Auger Base Leg Clamp.....	2
8.....	201-0007.....	3/8"-16 x 1" Hex Head Bolt, Grade 2, ZP.....	8
9.....	201-0120.....	5/16"-18 x 1" Hex Head Bolt, Grade 5, ZP.....	6
10.....	201-0351.....	5/8"-11 x 2" Hex Head Bolt, Grade 5, ZP.....	1
11.....	202-0070.....	5/16"-18 Hex Flange Whiz Lock Nut, ZP.....	10
12.....	202-0073.....	5/8"-11 Whiz Flange Lock Nut, ZP.....	1
13.....	203-0003.....	3/8" Flat Washer, ZP.....	8
14.....	203-0006.....	5/8" Flat Washer, ZP.....	4
15.....	203-0010.....	3/8" Lock Washer, ZP.....	8

DISCHARGE AUGER (Option)

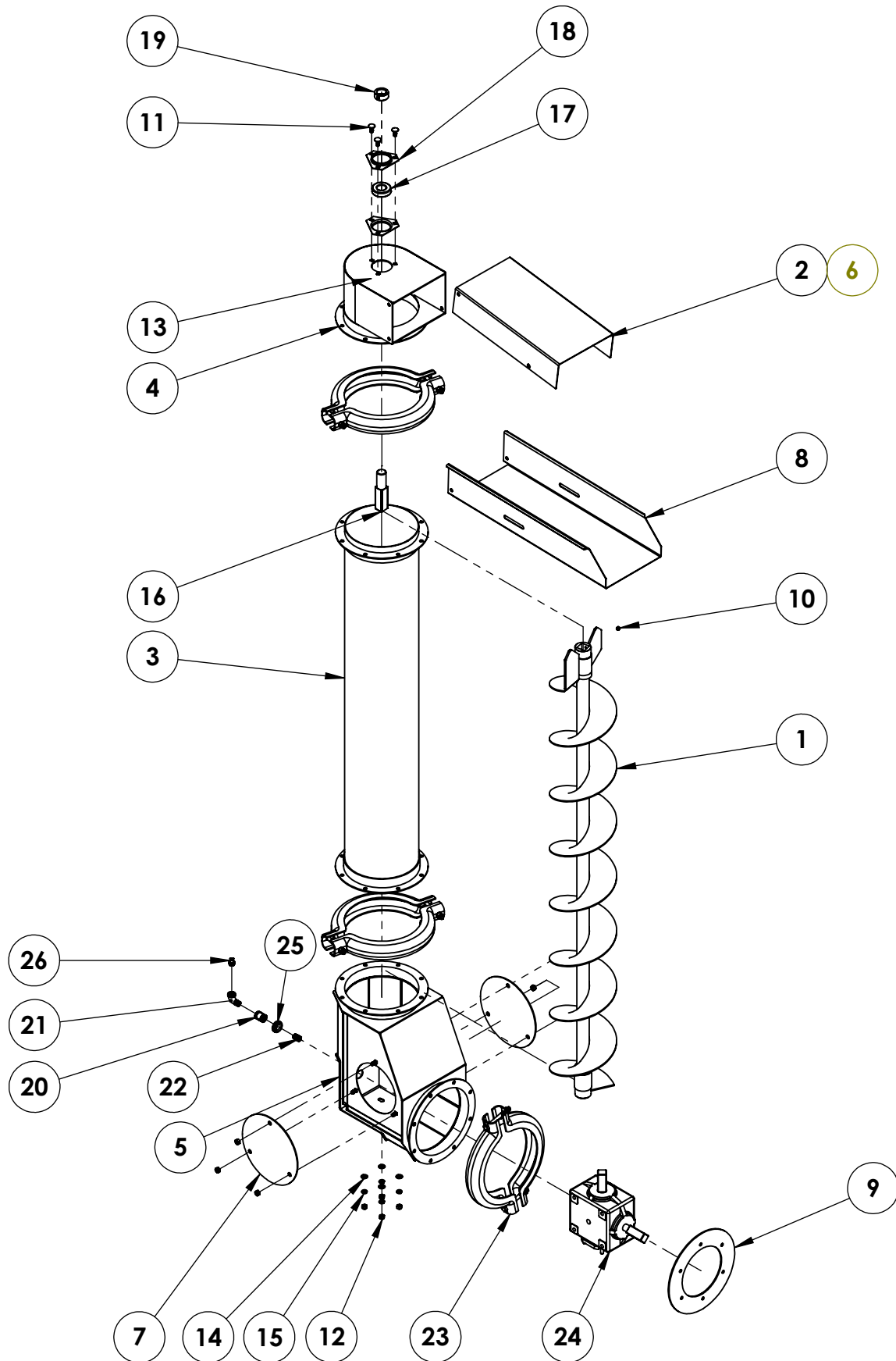

DISCHARGE AUGER CONTINUED (Option)

Item No.	Part No.	Description	Qty.
1.....	61-2188	8 x 5 Ft. Auger Screw	1
	61-2193	8/10 Ft. Auger Screw	
2.....	61-2205	8" Downspout Top Assembly	1
3.....	61-2207	8" Auger, 5 Ft. Tube Assembly	1
	61-2212	8" Auger, 10 Ft. Tube Assembly	
4.....	61-2227	8" Auger End Cap	1
5.....	61-2228	8" Elbow Weldment	1
6.....	63-0297	Nut & Bolt Discharge Spout Sack.....	1
7.....	101-2306	Clean Out Door Cover	2
8.....	101-3225	8" Downspout Bottom Panel.....	1
9.....	101-3228	6" Screw - 8" Elbow Adapter.....	1
10.....	201-0067	5/16"-18 x 5/16 Socket Head Cap Knurled, S.S.....	1
11.....	201-0119	5/16"-18 x 3/4" Carriage Bolt, Grade 5, ZP.....	3
12.....	202-0002	5/16"-18 Hex Nut, ZP.....	10
13.....	202-0070	5/16"-18 Hex Flange Whiz Lock Nut, ZP.....	3
14.....	203-0002	5/16" Flat Washer, ZP.....	4
15.....	203-0009	5/16" Lock Washer	4
16.....	207-0478	Auger Exit Shaft End Cap	1
17.....	209-0032	1" Flangette Bearing Insert.....	1
18.....	211-0023	1" Flangette Housing	2
19.....	221-0001	1" Lock Collar	1
20.....	224-0013	1/4" NPT Pipe Coupling.....	1
21.....	224-0019	1/4" NPT, 90° Street Elbow.....	1
22.....	224-0068	1/4" NPT Close Nipple.....	1
23.....	225-0039	Clamp Band Set 8	3
24.....	228-0012	Discharge Auger Gear Box.....	1
25.....	250-0060	11/16" x 1" Rubber Grommet.....	1
26.....	290-0285	1/4" NPT Plug.....	1

TROUBLESHOOTING

This section is designed to help you remedy problems if unsatisfactory operation occurs. If you are unable to determine and correct the trouble, consult one of our authorized dealers.

CAUTION: NEVER ATTEMPT TO LUBRICATE, ADJUST, OR OTHERWISE SERVICE THIS MACHINE UNTIL THE POWER HAS BEEN DISCONNECTED, LOCKED OUT AND ALL MOTION HAS STOPPED.

PROBLEM - EXCESSIVE ROLL WEAR

- 1 POSSIBLE CAUSE - Overfeeding, with excess grain continually sliding off the top of the rolls creating friction and excessive roll wear.
SUGGESTED REMEDY - Keep rolls "hungry". Adjust hopper gate to feed in only the amount of grain the rolls will take away. Usually, overfeeding is not the cause for wear on deep-grooved rolls.
 - 2 POSSIBLE CAUSE - Crushing abrasive materials other than grain.
SUGGESTED REMEDY - Mills are designed to be used only on grain, or other similar textured materials.
 - 3 POSSIBLE CAUSE - Foreign matter, such as metal, going between the rolls.
SUGGESTED REMEDY - Periodically check the magnetic grate for metal, nails, bolts, etc. and remove as necessary.
 - 4 POSSIBLE CAUSE - Gravel in the grain.
SUGGESTED REMEDY - Sand and small gravel is difficult to remove from grain because of similar sizes as grain. Larger gravel and small rocks can be removed by screening with wire hardware cloth on a frame mounted in the hopper.
-

PROBLEM - MILL IS HARD TO START

- 1 POSSIBLE CAUSE - Grain between rolls.
SUGGESTED REMEDY - Close hopper gate, and separate rolls to allow grain to fall through. The best remedy is to make a practice of closing hopper gate before stopping mill so no grain is left between the rolls.
-

PROBLEM - EXCESS VIBRATION

- 1 POSSIBLE CAUSE - Uneven flow of grain into the mill.
SUGGESTED REMEDY - Eliminate "surging of grain" into the mill as much as possible.
- 2 POSSIBLE CAUSE - Excess RPM.
SUGGESTED REMEDY - Recommended nominal operation speed of 1750 RPM (motor).
- 3 POSSIBLE CAUSE - Roll bearings worn or defective.
SUGGESTED REMEDY - Replace bearings.
- 4 POSSIBLE CAUSE - Feed rate is too fast for current roll spacing.
SUGGESTED REMEDY - Slow down the feed rate, or change the roll spacing. IMPORTANT: Changing roll spacing will affect feed particle size.
- 5 POSSIBLE CAUSE - Loose bolts on bearings or mill.
SUGGESTED REMEDY - Check for loose or missing hardware and replace or secure.

PROBLEM - WHOLE GRAIN COMING THROUGH MILL

- 1 POSSIBLE CAUSE - Improper setting of rolls. Roll spacing too wide.
SUGGESTED REMEDY - Rolls should be set closer together to crimp all grain being processed.
- 2 POSSIBLE CAUSE - Overfeeding the rolls.
SUGGESTED REMEDY - If the grain hopper gate is open too wide, the rolls will not take all the grain. The grain can build up above the rolls. This causes whole grain to overflow the rolls and escape being crushed. Reduce feed rate to minimize grain overflow. This should not happen while using Rubber Baffles - Ref. No. 16, Page 17.
- 3 POSSIBLE CAUSE - Uneven kernel size.
SUGGESTED REMEDY - The problem may only be that a few small, poorly developed whole kernels going through the mill. It is better not to set the mill to crack these if in doing so you would "over-roll" the majority of the kernels.
- 4 POSSIBLE CAUSE - Improper spring tension.
SUGGESTED REMEDY - Refer to factory recommendations regarding spring tension. See page 8.
- 5 POSSIBLE CAUSE - Rolls out of alignment.
SUGGESTED REMEDY - Realign rolls. See page 8.
- 6 POSSIBLE CAUSE - Baffles between rolls and hopper have too much clearance.
SUGGESTED REMEDY - Remove hopper and adjust baffle by bending material so clearance is less than 1/8 inch. Rubber baffles will "sing" for a while, but will quiet down after a few minutes.

PROBLEM - DISCHARGE AUGER SEEMS TO SLOW DOWN WHEN PLACED UNDER A LOAD

- 1 POSSIBLE CAUSE - Excessively wet or finely processed feed.
SUGGESTED REMEDY - The higher the moisture content, and the finer the feed material, the more power required to convey it through an auger. Adjust hopper gate to keep grain flow at a level where optimum auger speed and feed flow can be maintained. Check the tension of the v-belt that operates the auger base.

PROBLEM - HIGH PITCHED SOUND FROM RUBBER BAFFLES

- 1 POSSIBLE CAUSE - Baffles are touching the rolls when they leave the factory by design.
SUGGESTED REMEDY - Continue running the mill and when the rubber baffles wear a little, the sound will decrease.

PROBLEM - LOOSE PULLEYS

- 1 POSSIBLE CAUSE - Set screws are loose.
SUGGESTED REMEDY - Check set screws the first time the mill is operated and periodically thereafter.
- 2 POSSIBLE CAUSE - Key is worn or missing.
SUGGESTED REMEDY - Replace defective or missing keys.
- 3 POSSIBLE CAUSE - Pulleys are out of alignment.
SUGGESTED REMEDY - Realign pulleys so they are all parallel.
- 4 POSSIBLE CAUSE - Bushings are loose.
SUGGESTED REMEDY - Check all bolts and tighten if needed.

PROBLEM - GRAIN TOO FINE OR DUSTING OF GRAIN

- 1 POSSIBLE CAUSE - Over Rolling. Rolls are set too close together.
SUGGESTED REMEDY - Adjust spacing of rolls. (See Roll Spacing, Page 6)
- 2 POSSIBLE CAUSE - Rolling Mixed Grain.
SUGGESTED REMEDY - If mixed grain or different sizes are run together, to crack or crimp the smaller grain, the rolls “over-roll” or pulverize larger kernels. As a general rule, all grains should be rolled separately and then mixed.
- 3 POSSIBLE CAUSE - Failure to reset rolls for different varieties of grain.
SUGGESTED REMEDY - Always reset roll spacing each time a different grain is to be processed.
- 4 POSSIBLE CAUSE - Very dry or particularly hard grain.
SUGGESTED REMEDY - Open roll spacing wider than normal to eliminate over-rolling. In extreme cases, grain can be tempered by sprinkling a small amount of water over the grain to be rolled and letting it stand 8 to 12 hours. The amount of moisture needed depends on the dryness of the grain.

PROBLEM - ABNORMAL POWER REQUIREMENT

- 1 POSSIBLE CAUSE - High Moisture Grain (Overload on mill)
SUGGESTED REMEDY - Running damp, high moisture grain can cause it to “stick to the rolls,” and require an abnormal amount of power on new mills. Dry grain may stick to new rolls also, particularly when rolling oats or barley. This condition should not continue after rolling 200-300 bushels of grain.
- 2 POSSIBLE CAUSE - Opening hopper gate too fast or too far.
SUGGESTED REMEDY - Always open gate slowly and only as far as necessary to keep rolls “hungry”. Do not overfeed rolls and cause an excess build up of grain between the rolls. Feed only as much as the rolls will readily take.

ROLLER MILL LIMITED WARRANTY

Automatic Equipment Manufacturing Co. ("Automatic") warrants to the first retail purchaser that each item of equipment manufactured by Automatic shall be free from defect in material and workmanship under normal use and service for a period of one year from the date of delivery. In the case of equipment used for commercial or rental purposes, such warranty period is limited to 30 days from the date of delivery to the first retail purchaser.

During said one-year period (30 days in the case of equipment used for commercial or rental purposes), Automatic will repair or replace any parts which (a) shall be returned to an authorized dealer, distributor, or the factory, with transportation charges prepaid, and (b) after examination by Automatic, are found to be defective. This limited warranty will not cover, in any way, any alleged damages caused by incorrect or improper installation, improper use, modification or neglect of product, or failure of the user to follow the guidelines contained in the instructional material provided by Automatic. Automatic does not warrant electrical equipment or other items manufactured by any supplier other than Automatic.

THIS LIMITED WARRANTY IS IN LIEU OF ALL OTHER WARRANTIES, EXPRESS OR IMPLIED, AND THERE ARE NO WARRANTIES WHICH EXTEND BEYOND THE DESCRIPTION ON THE FACE HEREOF. AUTOMATIC EXPRESSLY DISCLAIMS AND EXCLUDES ANY AND ALL OTHER WARRANTIES, INCLUDING ANY WARRANTY OF MERCHANTABILITY OR OF FITNESS FOR A PARTICULAR PURPOSE. ANY LIABILITY OF AUTOMATIC FOR THE ALLEGED BREACH OF ANY WARRANTY OR CONTRACT WITH RESPECT TO ITS PRODUCTS SHALL BE LIMITED TO REPAIR OR REPLACEMENT AS SET FORTH IN THIS LIMITED WARRANTY AND IN NO EVENT SHALL AUTOMATIC'S LIABILITY EXCEED THE PURCHASE PRICE OF ITS PRODUCT. AUTOMATIC FURTHER LIMITS TO SUCH PURCHASE PRICE ITS LIABILITY OF ANY KIND ON ACCOUNT OF ANY NEGLIGENCE WHATSOEVER ON ITS PART WITH RESPECT TO ITS PRODUCTS. IN NO EVENT SHALL AUTOMATIC BE LIABLE FOR ANY INCIDENTAL OR CONSEQUENTIAL DAMAGES OR FOR ANY DAMAGES RESULTING FROM MISUSE OR MODIFICATION OF ITS PRODUCTS. THIS LIMITED WARRANTY SETS FORTH THE SOLE AND EXCLUSIVE REMEDY OF THE PURCHASER WITH RESPECT TO THIS PRODUCT.

Automatic reserves the right to make changes or add improvements to its products at any time without incurring any obligation to make such changes to previously manufactured equipment.

No liability is assumed for bodily injury that may be inflicted on the operator, spectator or general public who might be in the general area while this equipment is in use.

IMPORTANT: Coverage and performance under the foregoing limited warranty is contingent upon the first retail purchaser completing and returning the warranty registration card to Automatic within ten days of delivery date and upon the original serial number being visible on the product and unaltered. Automatic will not honor any warranty claims unless the warranty registration card is on file at Automatic's factory in Pender, Nebraska.

Automatic Equipment Manufacturing Co.
PO Box P, Pender, NE 68047
©12/93

TO BE VALID, WARRANTY CARD MUST BE COMPLETED IN ITS ENTIRETY BY AN AUTHORIZED DISTRIBUTOR OR DEALER AND SENT TO AUTOMATIC EQUIPMENT MFG. CO., PENDER, NEBRASKA. FAILURE TO DO SO WILL VOID THIS WARRANTY.

Please visit us at www.automaticag.com for our complete line of agricultural equipment.

It is a continuing policy of Automatic Equipment Manufacturing Company to make improvements. The company reserves the right to make these improvements without incurring any obligation to add them to machines already in the field. Many years of research combined with experience gained through close contact with operators have been drawn upon in designing your mill.

The logo for Automatic Equipment Manufacturing Company, featuring the word "Automatic" in a large, bold, black, stylized font. The letters are thick and rounded, with a slight shadow effect. The logo is centered between two solid black horizontal bars.

Automatic Equipment Mfg. Co. • One Mill Road, Industrial Park
Pender, Nebraska 68047 • 402-385-3051 • FAX 402-385-3360