

Farm King

OPERATOR AND PARTS MANUAL

BACKSAVER AUGER

Models 1370, 1385, 1395, 13114

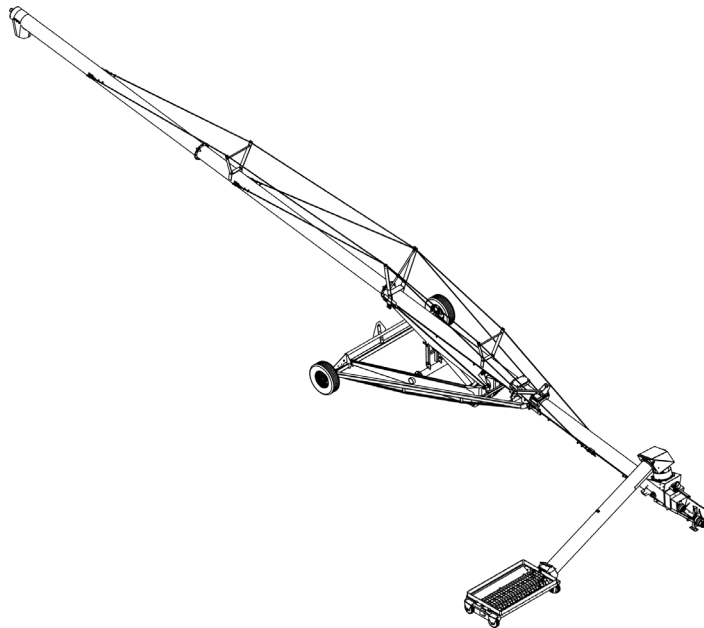

TABLE OF CONTENTS

Manufacturer's Statement: For technical reasons, Farm King reserves the right to modify machinery design and specifications provided herein without any preliminary notice. Information provided herein is of descriptive nature. Performance quality may depend on soil fertility, applied agricultural techniques, weather conditions, and other factors.

WARRANTY REGISTRATION FORM.....	3
INTRODUCTION.....	5
SAFETY.....	9
OPERATION.....	21
MAINTENANCE.....	43
PARTS IDENTIFICATION.....	61
SPECIFICATIONS.....	143
WARRANTY.....	153

Farm King



WARRANTY REGISTRATION FORM

This form must be filled out by the dealer and signed by both the dealer and the customer at the time of delivery. Forms may be faxed to 204-654-2503 ATTN: Farm King Service/Warranty Administrator. Forms may be emailed to warranty@buhlerindustries.com or submitted online at farmkingdealers.com.

Customer Name:	
Customer Address:	
City:	Prov / State:
Postal / Zip Code:	Phone:

Dealer Name:	
Dealer Address:	
City:	Prov / State:
Postal / Zip Code:	Phone:

Equipment Model:	Serial Number:	Delivery Date:
------------------	----------------	----------------

I have thoroughly instructed the buyer on the above described equipment which included the Operator and Parts Manual content, equipment care, adjustments, safe operation and applicable warranty policy.

Dealer Inspection Report:

- Bearings Turn Freely
- Winch Cable Tension Checked
- Bridging Cable Tension Checked
- Check Oil Level In Auger Drive Gear Box
- Fasteners Tight
- Lubricate Machine
- Check Tire Pressure
- Hopper Raises And Lowers Freely

Safety:

- Safety Chain On Hitch (if equipped)
- All Decals Installed
- Guards And Shields Installed And Secure
- Review Operating And Safety Instructions
- Check For Hydraulic Leaks
- Pre-Delivery Inspection Completed

Date:	Dealer Rep. Signature:
-------	------------------------

The above equipment and Operator And Parts Manual have been received by me and I have been thoroughly instructed as to care, adjustments, safe operation and applicable warranty policy.

Date:	Customer / Owner Signature:
-------	-----------------------------

Remove this Warranty Registration Form from the Operator And Parts Manual. Make two copies of the form. Send original Warranty Registration Form to Farm King. Give one copy to the customer and the dealer will keep one copy.

Farm King



INTRODUCTION

This Operator And Parts Manual was written to give the owner / operator instructions on the safe operation, maintenance and part identification of the Farm King equipment. READ AND UNDERSTAND THIS OPERATOR AND PARTS MANUAL BEFORE OPERATING YOUR FARM KING EQUIPMENT. If you have any questions, see your Farm King dealer. This manual may illustrate options and accessories not installed on your Farm King equipment.

OWNER'S INFORMATION.....	7
Serial Number Location.....	7
Manual Storage.....	7
EQUIPMENT IDENTIFICATION.....	8

Farm King



OWNER'S INFORMATION

Thank you for your decision to purchase a Farm King Backsaver Auger. To ensure maximum performance of your equipment, it is mandatory that you thoroughly study the Operator And Parts Manual and follow the recommendations. Proper operation and maintenance are essential to maximize equipment life and prevent personal injury.

Operate and maintain this equipment in a safe manner and in accordance with all applicable local, state, and federal codes, regulations and / or laws. Follow all on-product labeling and instructions.

Make sure that all personnel have read this Operator And Parts Manual and thoroughly understand safe and correct operating, installation and maintenance procedures.

Farm King is continually working to improve its products. Farm King reserves the right to make any improvements or changes as deemed practical and possible without incurring any responsibility or obligation to make any changes or additions to equipment sold previously.

Although great care has been taken to ensure the accuracy of this publication, Farm King makes no warranty or guarantee of any kind, written or expressed, implied or otherwise with regard to the information contained within this manual. Farm King assumes no responsibility for any errors that may appear in this manual and shall not be liable under any circumstances for incidental, consequential or punitive damages in connection with, or arising from the use of this manual.

Keep this manual available for frequent reference. All new operators or owners must review the manual before using the equipment and annually thereafter. Contact your Farm King Dealer if you need assistance, information, or additional copies of the manual.

Visit our website at www.farm-king.com for a complete list of dealers in your area.

The directions left, right, front and rear, as mentioned throughout this manual, are as viewed by the operator sitting in the tractor seat while towing the implement.

Serial Number Location

Please enter the model and serial number in the space provided for easy reference.

Figure 1

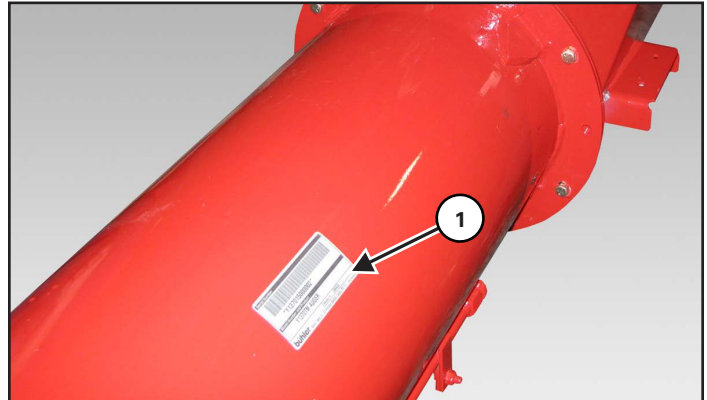

Model Number:
Serial Number:

The serial number plate (Item 1) is located on the intake tube [Figure 1].

Always use your serial number when requesting information or when ordering parts.

Manual Storage

Figure 2

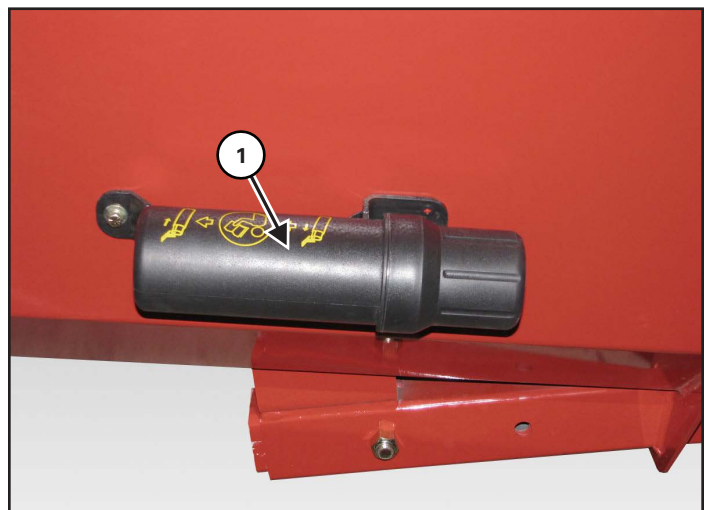

The operator and parts manual and other documents can be stored in the canister (Item 1) located on the LH undercarriage arm [Figure 2].

EQUIPMENT IDENTIFICATION

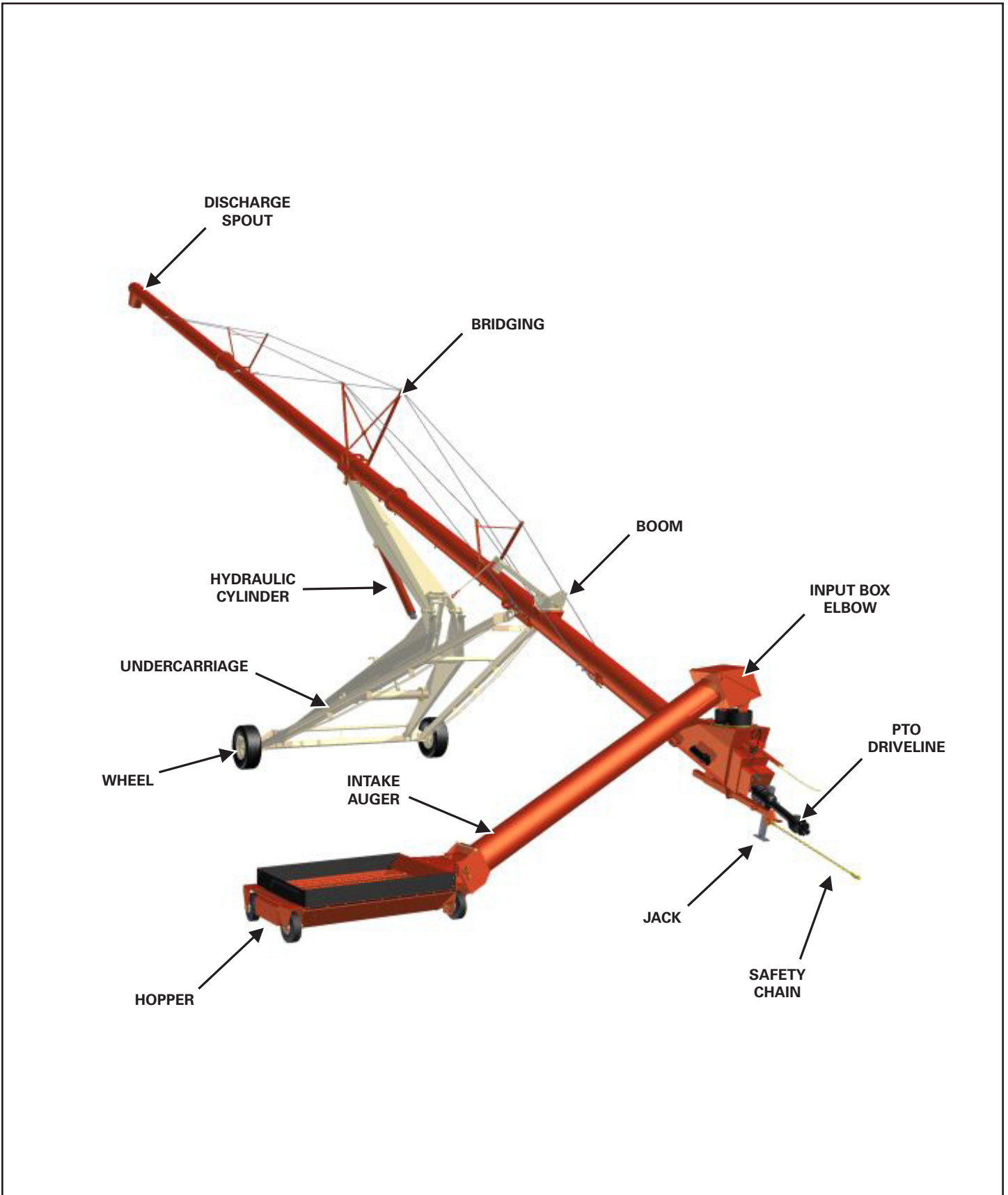

SAFETY

SAFETY INSTRUCTIONS.....	11
Safety Alerts.....	11
Safe Operation.....	11
Safety Rules.....	12
Safety Rules For Power Take-Off (PTO) Driven Equipment.....	12
Machine Requirements And Capabilities.....	13
Transport Safety.....	13
FIRE PREVENTION.....	14
Maintenance.....	14
Operation.....	14
Fire Extinguishers.....	14
Electrical.....	14
Hydraulic System.....	14
Fueling.....	14
Welding And Grinding.....	14
OPERATING SAFETY ZONES.....	15
EQUIPMENT & SAFETY SIGNS (DECALS).....	16
SAFETY SIGN-OFF FORM.....	20

Farm King



SAFETY INSTRUCTIONS

Safety Alerts



Safety Alert Symbol

This symbol with a warning statement means: "Warning, be alert! Your safety is involved!" Carefully read the message that follows.



The signal word CAUTION on the machine and in the manuals indicates a potentially hazardous situation which, if not avoided, may result in minor or moderate injury. It may also be used to alert against unsafe practices.



The signal word DANGER on the machine and in the manuals indicates a hazardous situation which, if not avoided, will result in death or serious injury.



The signal word WARNING on the machine and in the manuals indicates a potentially hazardous situation which, if not avoided, could result in death or serious injury.



This notice identifies procedures which must be followed to avoid damage to the machine.

Safe Operation



Operators must have instructions before operating the machine. Untrained operators can cause injury or death.

For an operator to be qualified, he or she must not use drugs or alcohol which impair alertness or coordination while working. An operator who is taking prescription drugs must get medical advice to determine if he or she can safely operate a machine and the equipment.

Understand the written instructions, rules and regulations:

- The written instructions from Farm King include the Warranty Registration, Dealer Inspection Report, Operator And Parts Manual and machine signs (decals).
- Check the rules and regulations at your location. The rules may include an employer's work safety requirements. Regulations may apply to local driving requirements or use of a Slow Moving Vehicle (SMV) emblem. Regulations may identify a hazard such as a utility line.

Have Training with Actual Operation:

- Operator training must consist of a demonstration and verbal instruction. This training is given by the machine owner prior to operation.
- The new operator must start in an area without bystanders and use all the controls until he or she can operate the machine safely under all conditions of the work area.

Know the Work Conditions:

- Clear working area of all bystanders, especially small children and all obstacles that might be hooked or snagged, causing injury or damage.
- Know the location of any overhead or underground power lines. Call local utilities and have all underground power lines marked prior to operation.
- Wear tight fitting clothing. Always wear safety glasses when doing maintenance or service.

Safety Rules

- Read and follow instructions in this manual and the tractor's Operators Manual before operating.
- Under no circumstances should young children be allowed to work with this equipment.
- This equipment is dangerous to children and persons unfamiliar with its operation.
- If the elderly are assisting with work, their physical limitations need to be recognized and accommodated.
- Stay clear of overhead power lines when raising or lowering the auger. Electrocutation can occur without direct contact.
- Check for overhead and / or underground lines before operating equipment (if applicable).
- In addition to the design and configuration of equipment, hazard control and accident prevention are dependent upon the awareness, concern, prudence and proper training of personnel involved in the operation, transport, maintenance and storage of equipment.
- Check that the equipment is securely fastened to the tractor / towing vehicle.
- Make sure all the machine controls are in the NEUTRAL position before starting the machine.
- Operate the equipment only from the operator's position.
- Operate the equipment according to the Operator And Parts Manual.
- When learning to operate the equipment, do it at a slow rate in an area clear of bystanders, especially small children.
- DO NOT permit personnel to be in the work area when operating the equipment.
- The equipment must be used ONLY on approved tractors / transport vehicles.
- DO NOT modify the equipment in any way.
- Unauthorized modification may impair the function and / or safety and could affect the life of the equipment.
- DO NOT make any adjustments or repairs on the equipment while the machine is running.
- Keep shields and guards in place. Replace if damaged.

Safety Rules For Power Take-Off (PTO) Driven Equipment

- Keep PTO shields and all guards in place. Replace damaged or missing shields and guards before operating.
- Follow warnings and instructions on machine signs (decals). Replace damaged or missing decals.
- Do not wear loose or bulky clothing around the PTO or other moving parts.
- Keep bystanders away from PTO driven equipment, and never allow children near machines.
- Read and understand the manuals for the PTO driven equipment and be aware of safe operating procedures and hazards that may not be readily apparent.
- Always walk around equipment to avoid coming near a turning PTO driveline. Stepping over, leaning across or crawling under a turning PTO driveline can cause entanglement.
- Position the machine and equipment hitch correctly to prevent driveline stress and separation.
- Use caution when turning. Turning too sharp can cause driveline damage.
- Use caution when raising PTO driven attachment.

Machine Requirements And Capabilities

- Stop the machine and engage the parking brake. Install blocks in front of and behind the rear tires of the machine. Install blocks underneath and support the equipment securely before working under raised equipment.
- Keep bystanders clear of moving parts and the work area. Keep children away.
- Use increased caution on slopes and near banks and ditches to prevent overturn.
- Make certain that the Slow Moving Vehicle (SMV) emblem is installed so that it is visible and legible. When transporting the equipment, use the flashing warning lights (if equipped) and follow all local regulations.
- Operate this equipment with a machine equipped with an approved Roll-Over Protective Structure (ROPS). Always wear seat belt when the ROPS is up. Serious injury or death could result from falling off the machine.
- Before leaving the operator's position:
 1. Always park on a flat level surface.
 2. Place all controls in neutral.
 3. Engage the parking brake.
 4. Stop engine.
 5. Wait for all moving parts to stop.
- Carry passengers only in designated seating areas. Never allow riders on the machine or equipment. Falling off can result in serious injury or death.
- Start the equipment only when properly seated in the operator's seat. Starting a machine in gear can result in serious injury or death.
- Operate the machine and equipment from the operator's position only.
- The parking brake must be engaged before leaving the operator's seat. Roll away can occur because the transmission may not prevent machine movement.

Transport Safety

- Do not exceed 20 mph (32 kph). Reduce speed on rough roads and surfaces.
- Comply with state and local laws governing highway safety and movement of machinery on public roads.
- The use of flashing amber lights is acceptable in most localities. However, some localities prohibit their use.
- Local laws should be checked for all highway lighting and marking requirements.
- Always install transport locks, pins or brackets before transporting.
- Always yield to oncoming traffic in all situations and move to the side of the road so any following traffic may pass.
- Always enter curves or drive up or down hills at a low speed and at a gradual steering angle.
- Never allow riders on either tractor or equipment.
- Keep tractor / towing vehicle in a lower gear at all times when traveling down steep grades.
- Maintain proper brake settings at all times (if equipped).
- Stay away from overhead power lines when auger is raised. Electrocutation can occur without direct contact.

FIRE PREVENTION



Maintenance

- The machine and some equipment have components that are at high temperatures under normal operating conditions. The primary source of high temperatures is the engine and exhaust system. The electrical system, if damaged or incorrectly maintained, can be a source of arcs or sparks.
- Flammable debris (leaves, straw, etc.) must be removed regularly. If flammable debris is allowed to accumulate, it can cause a fire hazard. Clean often to avoid this accumulation. Flammable debris in the engine compartment is a potential fire hazard.
- All fuels, most lubricants and some coolant mixtures are flammable. Flammable fluids that are leaking or spilled onto hot surfaces or onto electrical components can cause a fire.

Operation

- The Farm King machine must be in good operating condition before use.
- Check all of the items listed on the service schedule under the 8 hour column before operation. (See Maintenance section)
- Do not use the machine where exhaust, arcs, sparks or hot components can contact flammable material, explosive dust or gases.

Fire Extinguishers



- Know where fire extinguishers and first aid kits are located and how to use them. Inspect the fire extinguisher and service the fire extinguisher regularly. Obey the recommendations on the instructions plate.

Electrical



- Check all electrical wiring and connections for damage. Keep the battery terminals clean and tight. Repair or replace any damaged part or wires that are loose or frayed. Battery gas can explode and cause serious injury. Do not jump start or charge a frozen or damaged battery. Keep any open flames or sparks away from batteries. Do not smoke in battery charging area.

Hydraulic System

- Check hydraulic tubes, hoses and fittings for damage and leakage. Never use open flame or bare skin to check for leaks. Hydraulic tubes and hoses must be properly routed and have adequate support and secure clamps. Tighten or replace any parts that show leakage. Always clean fluid spills. Do not use gasoline or diesel fuel for cleaning parts. Use commercial nonflammable solvents.

Fueling



- Stop the engine and let it cool before adding fuel. No smoking! Do not refuel a machine near open flames or sparks. Fill the fuel tank outdoors.

Welding And Grinding

- Always clean the machine and equipment, disconnect the battery, and disconnect the wiring from the machine controls before welding. Cover rubber hoses, battery and all other flammable parts. Keep a fire extinguisher near the machine when welding.
- Have good ventilation when grinding or welding painted parts. Wear dust mask when grinding painted parts. Toxic dust or gas can be produced.
- Dust generated from repairing nonmetallic parts such as hoods, fenders or covers can be flammable or explosive. Repair such components in a well ventilated area away from open flames or sparks.

OPERATING SAFETY ZONES

 **WARNING**

AVOID INJURY OR DEATH

Do not allow small children, bystanders or unauthorized persons in the work area during operation.

Never stand or work under the auger and undercarriage when in the raised position or during operation.

Always keep PTO shields and all guards in place during operation.

Keep away from moving parts.

Keep everyone clear when operating the hopper mover.

 **DANGER**

ELECTROCUTION HAZARD

Keep away from power lines, electrocution can occur without direct contact.

 **CAUTION**

Owners and operators should allow only authorized personnel and grain transport vehicles near the auger or inside the work area.

Allow adequate space for grain transport vehicles to operate safely.

Make certain everyone is clear of the equipment before applying power or moving the machine.

While in operation, always support the discharge end or provide adequate anchorage of the intake end to prevent sudden tipping.

Figure 3

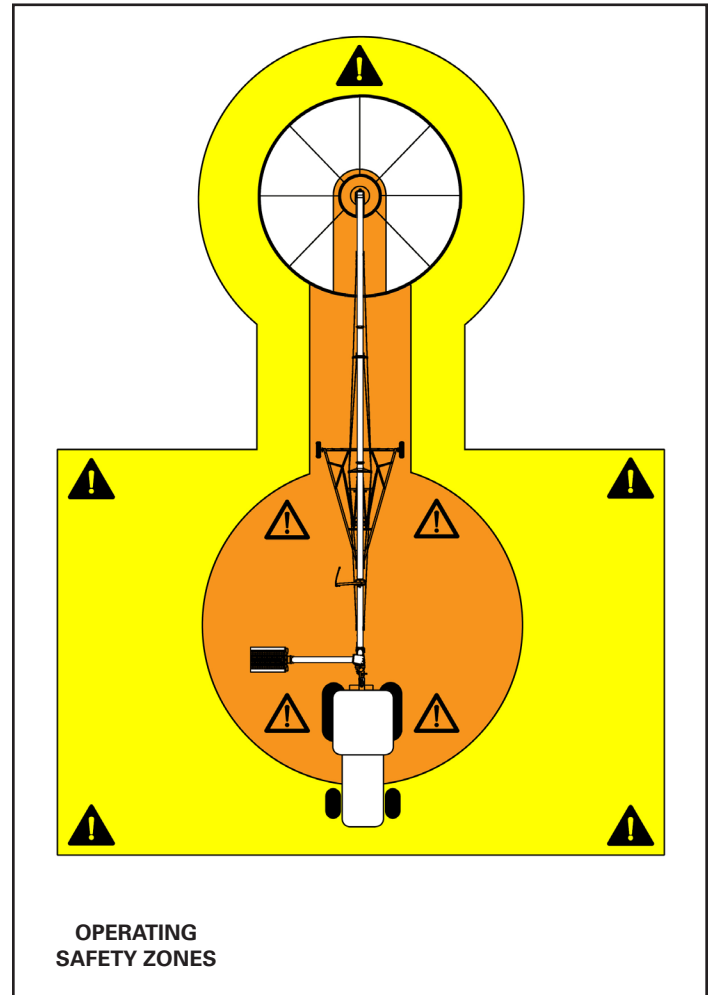

EQUIPMENT & SAFETY SIGNS (DECALS)

Follow the instructions on all the signs (decals) that are on the equipment. Replace any damaged signs (decals) and be sure they are in the correct locations. Equipment signs are available from your Farm King equipment dealer.

Figure 4

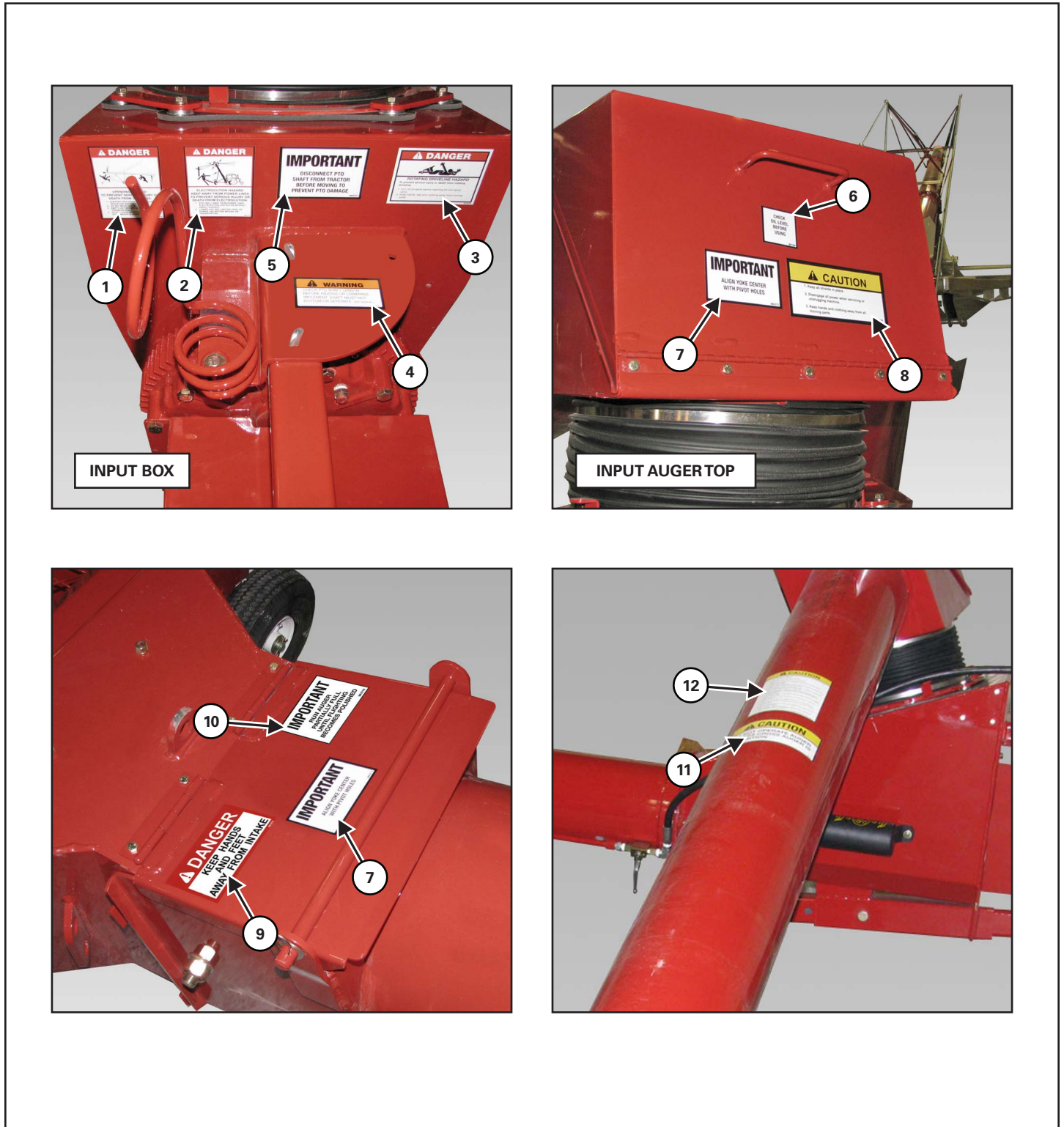

Decal Identification [Figure 4]

Electrocution Hazard, PN 909745 (Item 1)



Upending Hazard, PN 960569 (Item 2)



Driveline Hazard, PN 904585 (Item 3)



PTO Warning, PN 108431 ((Item 4)



PTO Important, PN 960371 (Item 5)



Check Oil, PN 967388 (Item 6)



Align Yoke, PN 960372 (Item 7)

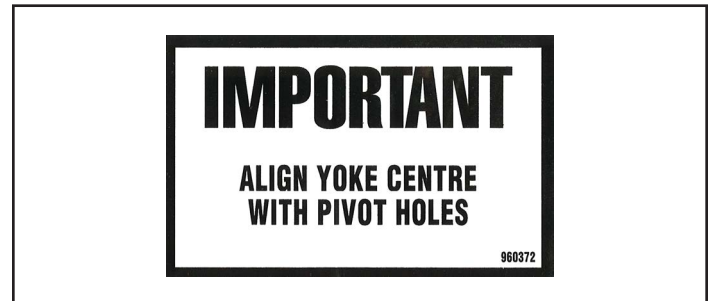

Caution, PN 963206 (Item 8)



Danger, PN 961016 (Item 9)



Run Auger, PN 961015 (Item 10)



Intake Caution, PN 917765 (Item 11)



List Caution, PN 961017 (Item 12)

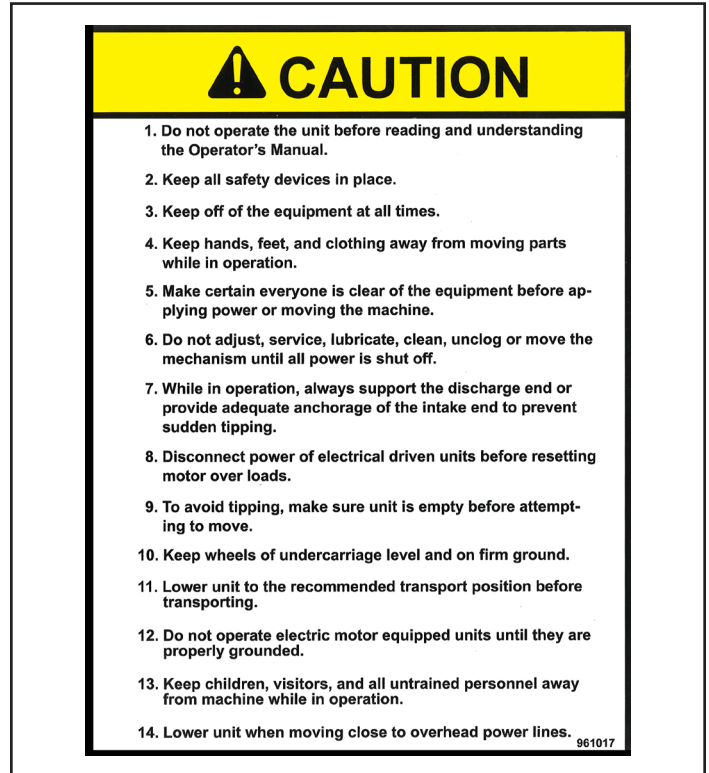
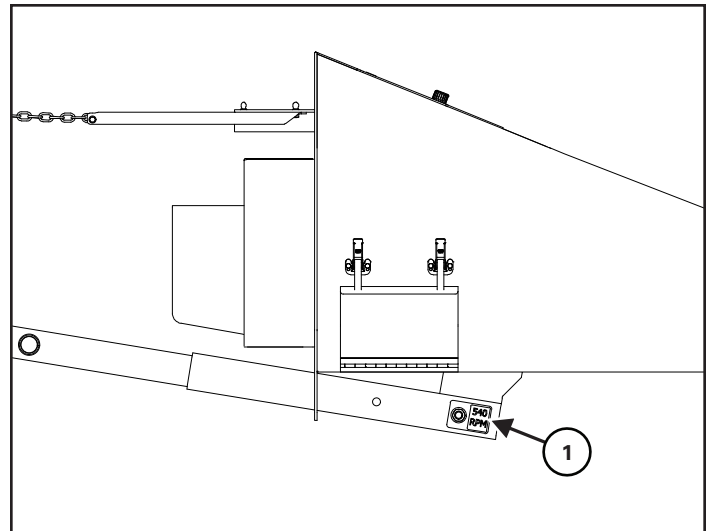
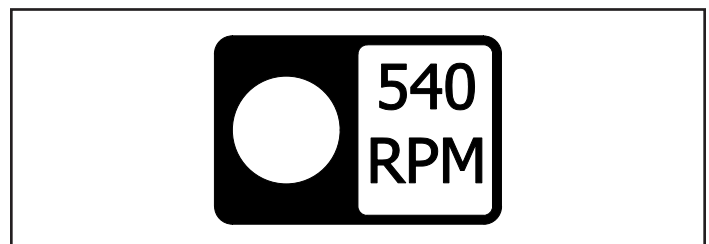

Figure 5



PTO rpm, PN 936775 (Item 1) [Figure 5]



Model Number Decals

1370, PN 910575



1385, PN 910577

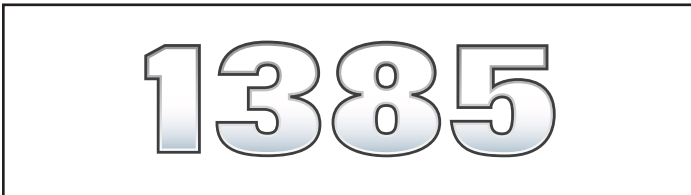

1395, PN 910578

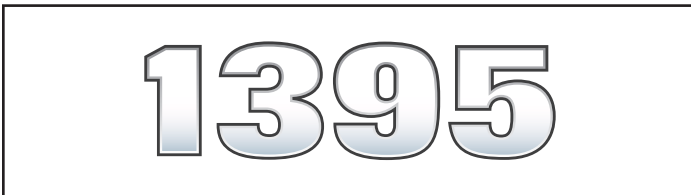

13114, PN 928081



BS13 Farm King 4.5" x 30.5", PN 910601

BS13114 Farm King 7.1" x 44.9", PN 935029



Reflectors, Other Decals

Amber, PN 52773-000

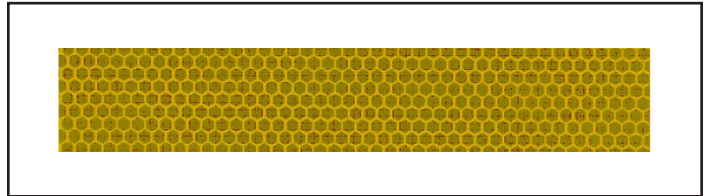

Red, PN 52774-000

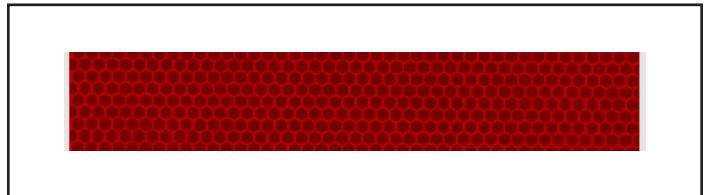

Grease Location, PN 966699

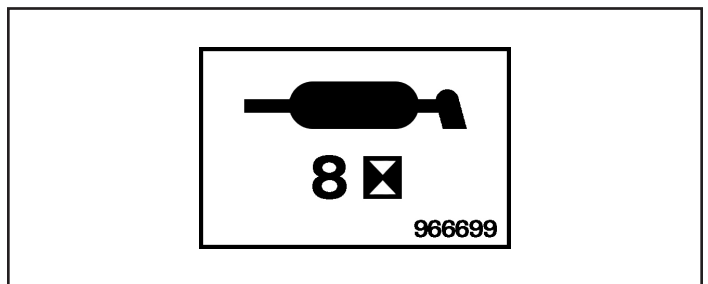

OPERATION

GENERAL INFORMATION.....	23
Pre - Operation Checklist.....	23
Break - In Checklist.....	24
Tractor And Gas Engine Requirements.....	25
Drawbar Adjustment.....	25
ENTERING & LEAVING THE OPERATOR'S POSITION.....	26
Entering The Operator's Position.....	26
Leaving The Operator's Position.....	26
CONNECTING TO TRACTOR.....	26
Hitching The Equipment.....	26
Connecting The PTO Driveline.....	27
PTO Driveline Length Check.....	29
PTO Driveline Bottoming Out Check.....	29
Reducing The PTO Driveline Length.....	30
PTO Driveline Engagement Check.....	31
Connecting Hydraulic Hoses.....	32
AUGER OPERATION.....	33
Main Lift Cylinder Adjust.....	34
Auger Placement.....	35
Unloading Belly Dump Units.....	36
Unloading Rear And Side Dump Units.....	38
TRANSPORTATION.....	39
Requirements.....	39
Transporting Procedure.....	40

Farm King



GENERAL INFORMATION

Pre - Operation Checklist

Before operating the auger for the first time and each time thereafter, check the following items:



AVOID INJURY OR DEATH

- Disengage the PTO, engage the machine’s parking brake, stop the engine and make sure all rotating components are completely stopped before connecting, disconnecting, adjusting or cleaning any PTO driven equipment.
- Always keep PTO shields and all guards in place when using PTO driven equipment.
- Disengage PTO for road travel.
- Keep hands, feet and clothing away.



AVOID INJURY OR DEATH

Wear safety glasses to prevent eye injury when any of the following conditions exist:

- When fluids are under pressure.
 - Flying debris or loose material is present.
 - Engine is running.
 - Tools are being used.
-
1. Lubricate the equipment per the schedule outline in the Maintenance Section.
 2. Check the augers. Remove any material build-up or debris that has become entangled.

3. Make sure that all guards and shields are in place, secured and functioning as designed.



HIGH PRESSURE FLUID HAZARD

Leaking fluids under pressure can enter the skin and cause serious injury or death. Immediate medical attention is required. Wear goggles. Use cardboard to check for leaks.

4. Check condition of all hydraulic components for leaks. Repair as required.

NOTE: Do not operate with hydraulic leaks.

5. Check and tighten all wheel bolts to proper torque.
6. Check tire pressure. Inflate per manufacturer’s specification.
7. Check gearbox oil level. Fill as required. (See Maintenance section).
8. Check that the PTO driveline telescope easily and turn freely.
9. Make sure the PTO ends are securely attached to the auger and the tractor.
10. Check the drive belt tension and alignment. Tension or align as required. (See Maintenance section).

Break - In Checklist

The break-in period is different from normal operating conditions.

The tube and flighting must get a polished surface through use. Once the new auger has polished, it will run smooth at recommended speed.

NOTE: Never operate an empty auger for over one minute, as the flighting and housing will experience excessive wear.

During the break-in-period:

1. Run the tractor at slow idle until grain begins to flow from the discharge. For the first 500 bushels, operate at the slow speed and restrict the flow of grain at the intake.
2. Gradually increase the speed until operating at full PTO speed.

NOTE: Do not run empty during break-in period.



AVOID INJURY OR DEATH

- Disengage the PTO, engage the machine’s parking brake, stop the engine and make sure all rotating components are completely stopped before connecting, disconnecting, adjusting or cleaning any PTO driven equipment.
- Always keep PTO shields and all guards in place when using PTO driven equipment.
- Disengage PTO for road travel.
- Keep hands, feet and clothing away.

Check the following mechanical items after 1 hour of operation and again after 10 hours of operation:

1. Re-torque wheel bolts to proper torque and check tire pressure.
2. Check for loose fasteners and hardware. Tighten as required.
3. Check the condition of all hydraulic lines, hoses, fittings and couplers for damage or leaks.
4. Tighten leaking fittings and repair or replace any damaged components.
5. Check the condition of all electrical lines, wires, and connections. Repair or replace any damaged systems or components.
6. Check that all guards and shields are in place, secured and functioning as designed.

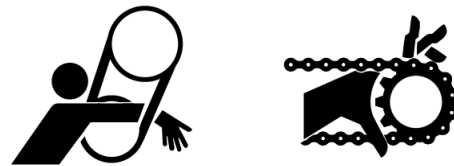

ROTATING PART HAZARD

To prevent serious injury or death from rotating parts:

- Place all controls in neutral or off, stop engine or motor, remove ignition key or disable power source and wait for all moving parts to stop before servicing, adjusting, repairing or unplugging.
- Install and secure all guards / shields before operating.
- Do not operate with rotating parts exposed.

Tractor And Gas Engine Requirements



Do NOT exceed 540 RPM PTO if equipped with chain drive.

Do NOT exceed 1000 RPM PTO if equipped with optional M1000 gearbox.

Keep PTO shields and all guards in place.

Keep away from moving parts.

Keep bystanders away.

The tractor / tow vehicle must be rated for the listed weight to transport the specified auger model.

Hitch weight and total weight of the auger models:

Auger Model	Hitch Weight	Total Weight
1370	1140 lb (518 kg)	5175 lb (2350 kg)
1385	1270 lb (577 kg)	6381 lb (2897 kg)
1395	1530 lb (694 kg)	6683 lb (3034 kg)
13114	2922 lb (1328 kg)	15140 lb (4045 kg)

The tractor must be equipped with a 6-spline 1-3/8" (standard) or 21-spline 1-3/8" (optional) when used with the 13" Backsaver Auger.

Minimum HP (540 RPM PTO):

Auger Model	Minimum Tractor HP
1370	80 HP
1385	90 HP
1395	100 HP
13114	165 HP

Drawbar Adjustment

Figure 6

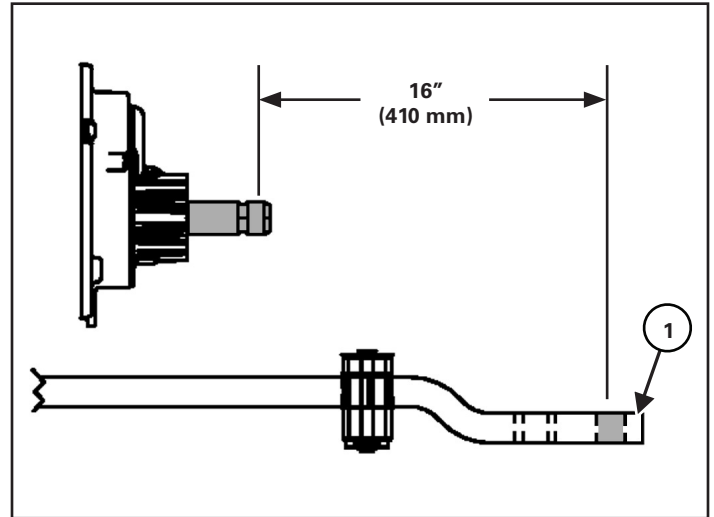

Adjust the tractor's drawbar in / out, until the center of the hitch pin hole (Item 1) is 16 inches (410 mm) from the end of the tractor's PTO shaft. See your tractor's owner's manual for correct adjustment procedures [Figure 6].

NOTE: A tractor hitch of less than 16" minimum will result in PTO bottoming out, when operating auger at maximum height.

Figure 7

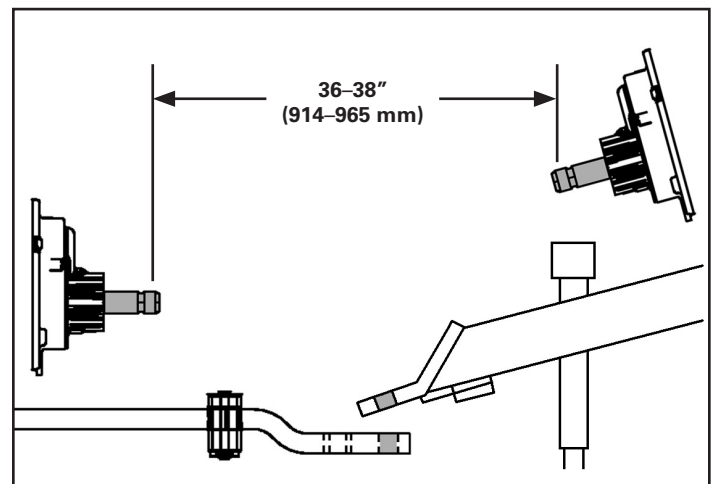

The distance between the tractor and the auger PTO shaft should be between 36-38 in. (914-965 mm) with the tractor and auger on level ground and the auger in full down position. This distance is obtained by either adjusting the tractor hitch, the auger hitch or both [Figure 7].

ENTERING & LEAVING THE OPERATOR'S POSITION

Entering The Operator's Position

Enter the operator's position, start the engine, and release the parking brake.



IMPORTANT

Follow the instructions in your tractor's operation manual for the correct procedure.

Leaving The Operator's Position

Always perform the following steps when leaving the operator's position:



WARNING

AVOID INJURY OR DEATH

Before you leave the operator's position:

- Always park on a flat level surface.
- Place all controls in NEUTRAL.
- Engage the park brake.
- Stop the engine and remove the key.
- Wait for all moving parts to stop.

CONNECTING TO TRACTOR

Hitching The Equipment

Attach the auger to the tractor whenever the equipment is moved around the yard or into working position.

Tow the equipment by truck when traveling long distances (see "**Transportation**" on page 39).

Make sure that bystanders, especially small children, are clear of the working area.

Be sure that there is sufficient room and clearance to back up to the machine.



WARNING



Before moving the tractor, look in all directions and make sure no bystanders, especially small children are in the work area. Do not allow anyone between the tractor and the equipment when backing up to the equipment for connecting.

Move the tractor backwards, aligning the drawbar with the Backsaver Auger hitch.

NOTE: The jack may need to be lowered or raised for proper alignment of the drawbar and hitch.

If the Backsaver Auger hitch needs to be adjusted, stop the tractor when drawbar is just in front of the Backsaver Auger hitch.

Leave the operator's position.

Figure 8

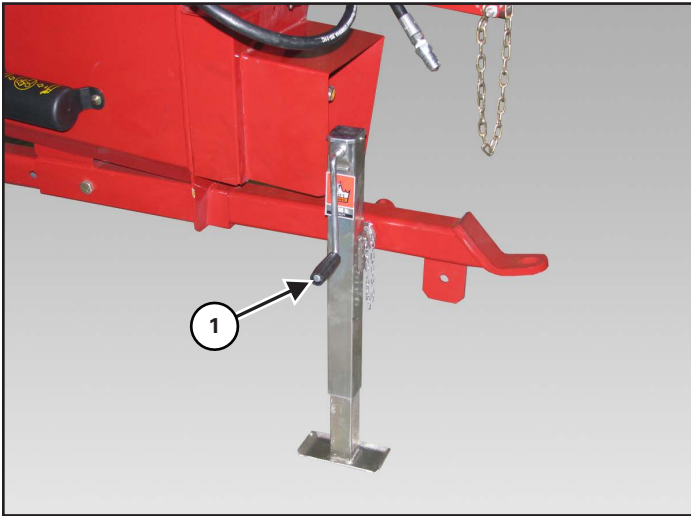

Turn the handle (Item 1) clockwise to raise the hitch or counterclockwise to lower the hitch [Figure 8].

Lower or raise the Backsaver Auger hitch until aligned with the tractor's drawbar.

Move to the operator's seat, start the engine and release the parking brake.

Move the tractor backwards, aligning the drawbar hitch pin hole with the Backsaver Auger hitch pin hole(s).

Stop the tractor and leave operator's position.

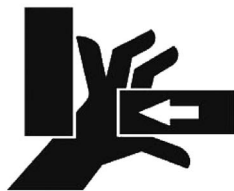

AVOID INJURY OR DEATH

Keep fingers and hands out of pinch points when connecting and disconnecting equipment.

NOTE: Always use a hitch pin of adequate size and strength and a retaining pin with a locking device.

Figure 9

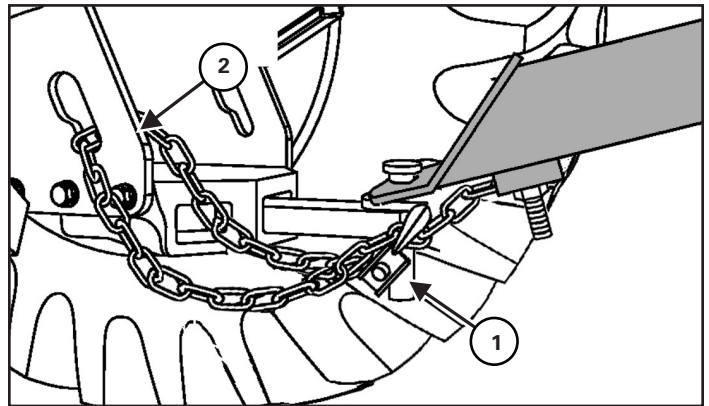

Install the hitch pin (Item 1) and retaining pin to securely fasten the Backsaver Auger hitch to the tractor drawbar [Figure 9].

Attach the safety chain (Item 2) around the drawbar [Figure 9].

Connecting The PTO Driveline



AVOID INJURY OR DEATH

Warnings on the machine and in the manuals are for your safety. Failure to obey warnings can cause serious injury or death.

NOTE: Clean and grease tractor's PTO shaft and PTO driveline coupling each time driveline is connected.

Stop the engine and leave the operator's position.



Improper hitch installation can cause PTO driveline damage. Do not modify the hitch or use an unapproved hitch. Make sure the PTO driveline is of adequate length and that u-joints are in the correct phase

Remove the PTO driveline from the storage position (if applicable).

Figure 10

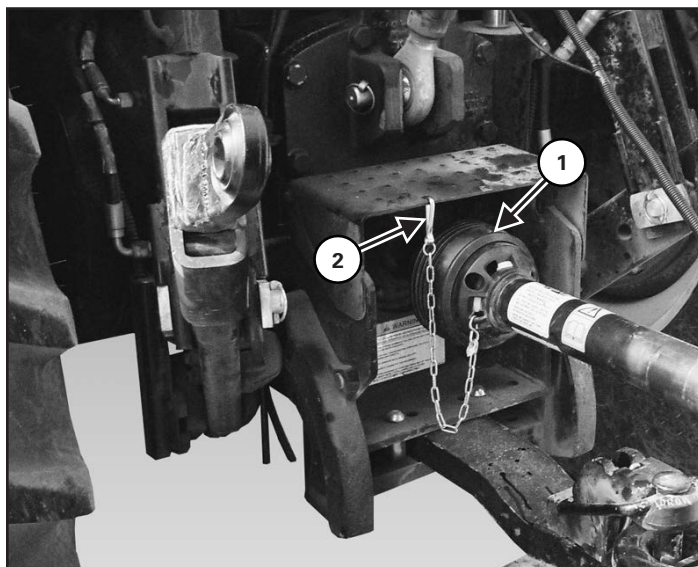

Retract the collar and slide the PTO driveline (Item 1) onto the tractor PTO shaft until it locks onto the shaft. Push and pull on the PTO driveline to verify it is securely attached to the PTO shaft. Install PTO driveline safety chain (Item 2) [Figure 10].

NOTE: The PTO driveline must have a means to retain it to the PTO shaft on the tractor.

Figure 11

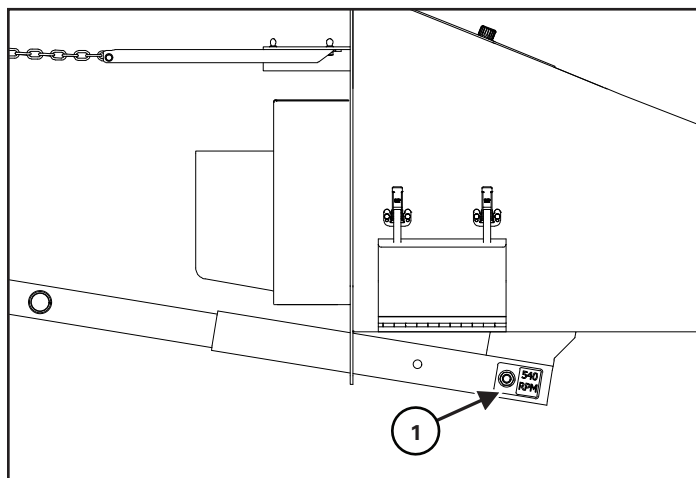

Adjust the hitch in the mount. Attach at proper hole (Item 1) depending on PTO rating. See identifying decal [Figure 11].



AVOID INJURY OR DEATH

Do NOT exceed 540 RPM PTO if equipped with chain drive.

Do NOT exceed 1000 RPM PTO if equipped with optional M1000 gearbox.

Keep PTO shields and all guards in place.

Keep away from moving parts.

Keep bystanders away.

PTO Driveline Length Check

Due to variations in distances between tractor PTO shafts and implement input shafts, drivelines may need to be shortened or a longer shaft may be required.

When fitting the implement to the tractor, the PTO driveline, with telescoping sections, must be inspected. When the sections are at the most compressed operating position, the sections must not “bottom out”.

At its shortest length, there must be at least 2 in. (50.8 mm) of clearance between each section end and opposite section end at the most compressed operating position.

When the sections are at the most extended position, there must be sufficient engagement between the sections.

At its farthest operating extension, a minimum section engagement of 33% of shaft length must be maintained.



WARNING

AVOID INJURY OR DEATH

- Do NOT exceed the rated implement PTO speed.
- Stay clear of rotating driveline.
- Keep bystanders away.
- Keep hands, feet, clothing and long hair away.
- Keep PTO shields and all guards in place.
- Disengage PTO, move the tractor controls to the Neutral position, stop the engine and make sure all rotating components are stopped before leaving the operator’s position.
- Do NOT service the tractor or implement with the PTO engaged.
- Do NOT service the implement in a raised position unless properly blocked and with all rotating components stopped.
- Disengage PTO for road travel.

PTO Driveline Bottoming Out Check

Stop the engine and leave the operator’s position. See See “Entering & Leaving The Operator’s Position” on page 26.

Make sure the PTO driveline and all rotating components have come to a complete stop before leaving the operator’s position (if applicable).

Figure 12

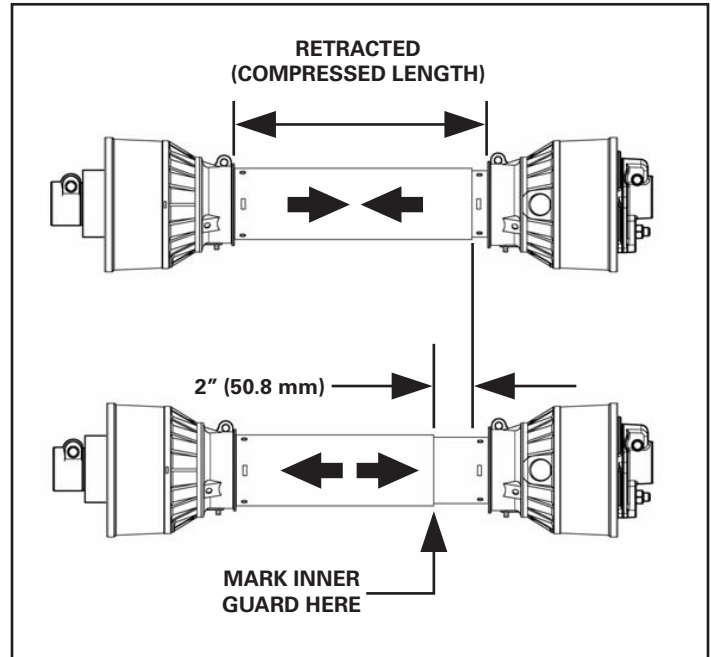

1. Disconnect the PTO driveline from the tractor and slide the PTO driveline together until fully retracted (compressed).
2. Measure the retracted (compressed) length of PTO driveline [Figure 12].
3. Extend the PTO driveline 2 in. (50.8 mm) from the retracted length and place a mark on the inner guard at the end of the outer guard [Figure 12].
4. Reattach the PTO driveline to the tractor PTO shaft.
5. Enter the operator’s position. Start the engine.
6. With the rear PTO DISENGAGED, raise and lower the implement and watch the PTO driveline extend and retract.
7. If the outer PTO driveline guard slides in (retracts) over the mark at any point of travel, the PTO driveline needs to be shortened.

Reducing The PTO Driveline Length

Stop the engine and leave the operator's position. See "Entering & Leaving The Operator's Position" on page 26.

Make sure the PTO driveline and all rotating components have come to a complete stop before leaving the operator's position.



AVOID INJURY OR DEATH

- Do NOT exceed the rated implement PTO speed.
- Stay clear of rotating driveline.
- Keep bystanders away.
- Keep hands, feet, clothing and long hair away.
- Keep PTO shields and all guards in place.
- Disengage PTO, move the tractor controls to the Neutral position, stop the engine and make sure all rotating components are stopped before leaving the operator's position.
- Do NOT service the tractor or implement with the PTO engaged.
- Do NOT service the implement in a raised position unless properly blocked and with all rotating components stopped.
- Disengage PTO for road travel.

Remove the PTO driveline from the tractor and place in storage position (if equipped).

Enter the operator's position (See "Entering The Operator's Position" in the Operation section). Start the engine.

Raise or lower the three-point implement to get the shortest distance between the tractor PTO shaft and three-point implement gearbox PTO shaft. Stop the engine and leave the operator's position.

Pull the PTO driveline apart and reinstall each individual section; one half to the tractor PTO shaft and one half to the implement gearbox PTO shaft.

Figure 13

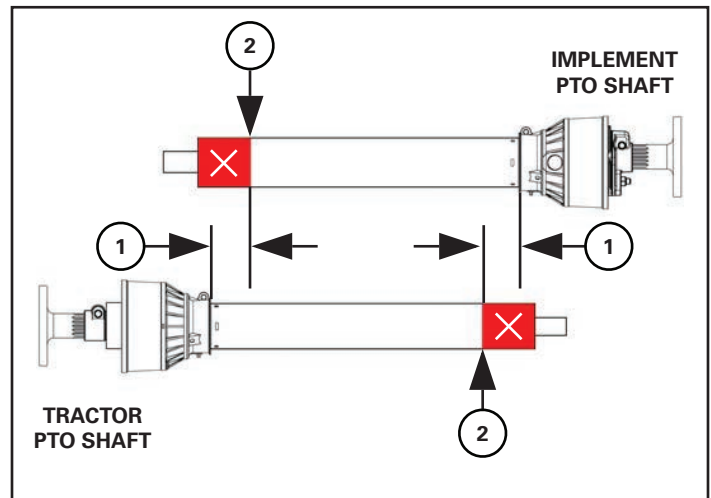

1. Hold PTO driveline sections parallel to one another and measure back 2 in. (50.8 mm) (Item 1) from the yoke of each section and place mark on opposite section. Cut the plastic shield at this length (Item 2) [Figure 13].

Figure 14

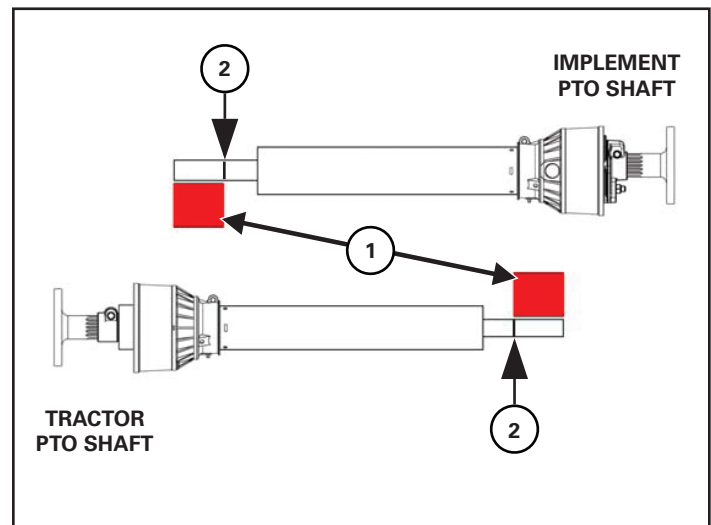

2. Using the plastic guard lengths that were cut off in, align the cut off lengths (Item 1) with the end of the inner & outer shafts. Place a mark (Item 2) on the inner & outer shafts and cut the inner & outer shafts off at this length [Figure 14].
3. Round off all sharp edges and debur.
4. Thoroughly grease and install the PTO driveline halves together.
5. Recheck for proper operation.

PTO Driveline Engagement Check

Stop the engine and leave the operator’s position. See **“Entering & Leaving The Operator’s Position”** on page 26.

Make sure the PTO driveline and all rotating components have come to a complete stop before exiting the tractor.



AVOID INJURY OR DEATH

- Do NOT exceed the rated implement PTO speed.
- Stay clear of rotating driveline.
- Keep bystanders away.
- Keep hands, feet, clothing and long hair away.
- Keep PTO shields and all guards in place.
- Disengage PTO, move the tractor controls to the Neutral position, stop the engine and make sure all rotating components are stopped before leaving the operator’s position.
- Do NOT service the tractor or implement with the PTO engaged.
- Do NOT service the implement in a raised position unless properly blocked and with all rotating components stopped.
- Disengage PTO for road travel.

1. Disconnect the PTO driveline from the tractor and fully slide the driveline sections together (retracted).
2. Measure the retracted (compressed) length of the PTO driveline between the bases of the plastic guards.
3. Multiply the retracted driveline length by 1.667 to determine the PTO driveline Maximum Operating Length. (i.e.: 25.5 in. (647.7 mm) x 1.667= 42.5 in. (1079.7 mm) Maximum Operating Length).
4. Attach the PTO driveline to the tractor PTO output shaft.
5. Enter the operator’s position (see “Entering The Operator’s Position” in the Operation section).

6. With the PTO driveline attached, position the three-point implement to where the telescoping PTO driveline is at its maximum operating extension.
7. Stop the engine and leave the operator’s position. Make sure the PTO driveline and all rotating components have come to a complete stop before leaving the operator’s position.
8. Measure the length of the PTO driveline between the bases of the plastic shields to determine the maximum operating length [Figure 15].

If the measured maximum operating length is less than the Maximum Operating Length calculation (from Step 3), the PTO driveline has adequate engagement

If the measured maximum operating length is equal to or more than the Maximum Operating Length calculation (from Step 3), the PTO driveline does not have adequate engagement and should be replaced with a longer driveline. See your Farm King dealer for available PTO drivelines.

Figure 15

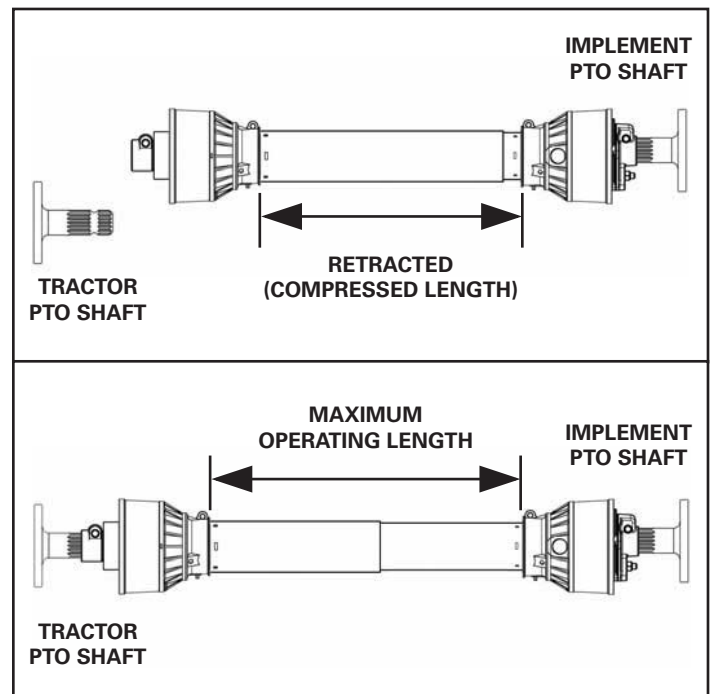

Connecting Hydraulic Hoses



HIGH PRESSURE FLUID HAZARD

To prevent serious injury or death from high pressure fluid:

- Relieve pressure on system before repairing or adjusting.
- Wear proper hand and eye protection when searching for leaks. Use wood or cardboard instead of hands.
- Keep all components in good repair.



Contain and dispose of any oil leakage in an environmentally safe manner.

Thoroughly clean the quick couplers before making connections. Dirt can quickly damage the system.

NOTE: Make sure the quick couplers are fully engaged. If the quick couplers do not fully engage, check to see that the couplers are the same size and type.

To Connect:

Figure 16

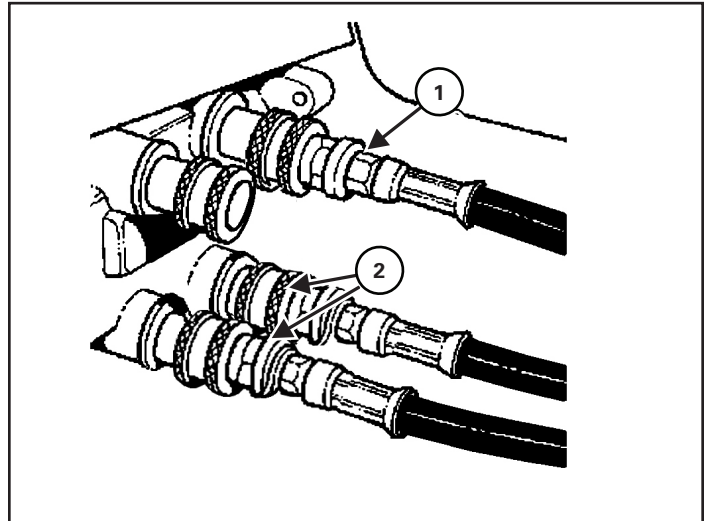

Pull back on the collar of the female coupler, push couplers together, release the collar when the couplers are fully engaged and locked [Figure 16].

Install the lift cylinder quick coupler hose (Item 1) [Figure 16].

Install the two valve block quick coupler hoses (Item 2) [Figure 16].

To Disconnect:

Pull back on the collar and pull the male coupler out to disconnect.

Lower jack until weight of equipment is resting on tractor drawbar. Pull lock pin on jack and remove. Mount jack to storage bracket and secure with lock pin.

AUGER OPERATION

Hopper Operation

Mechanical Winch: Move the winch handle counterclockwise (towards the hitch) to raise the lift boom cable (wind cable). Move the handle clockwise (away from the hitch) to lower the boom cable (unwind cable).

Hydraulic Winch: Engage the hydraulic circuit for the hopper / winch control valve on the intake box. Run the tractor engine at low idle.



ENTANGLEMENT HAZARD

To prevent injury to fingers and hands:

- Keep hands clear of winch during operation.

CUT HAZARD

To prevent injury to fingers and hands:

- Always wear heavy leather gloves when handling a wire rope and operating the winch.
- Never guide the cable with your hands.
- Never let wire rope slip through your hands.

Frayed, kinked or damaged wire rope must be replaced immediately.

Always stand clear and keep others away during operation.

Never touch wire rope or hook while in tension or under load.

Never touch wire rope or hook during winching operation.



Always maintain a minimum of three wraps of cable on the drum of the winch.

Figure 17

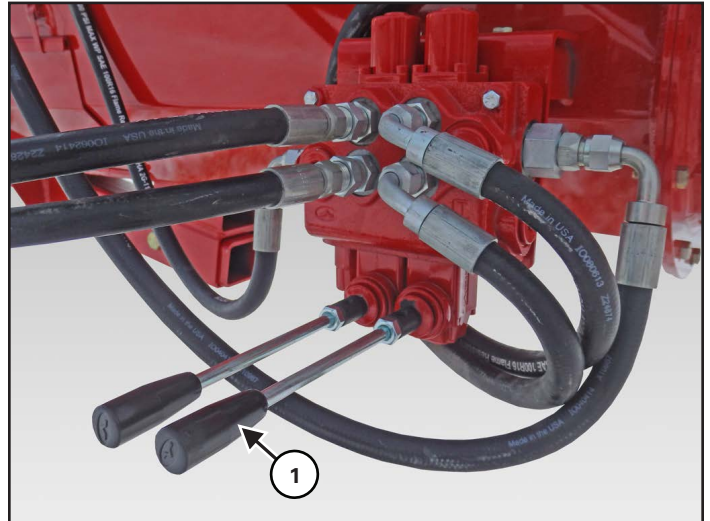

Hydraulic Winch: Move the lever (Item 1) down to raise the boom cable (wind cable). Move the lever up to lower the boom cable (unwind cable) [Figure 17].

Figure 18

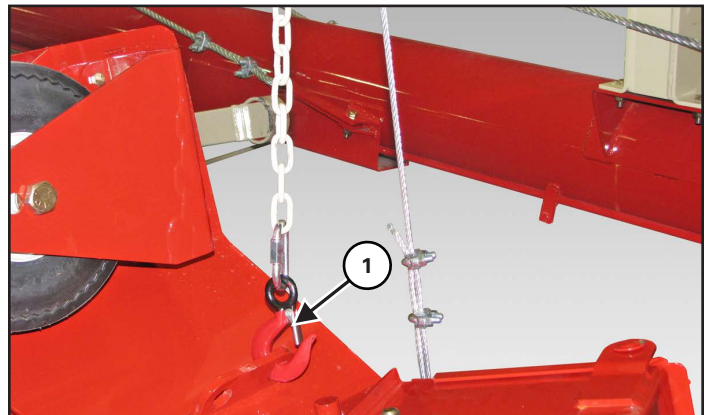

Raise the hopper and release the safety chain tension. Remove the safety chain hook (Item 1) from the hopper [Figure 18].

Slowly lower the hopper to the ground. Continue turning the winch handle until cable has enough slack to be removed from the hopper.

Figure 19

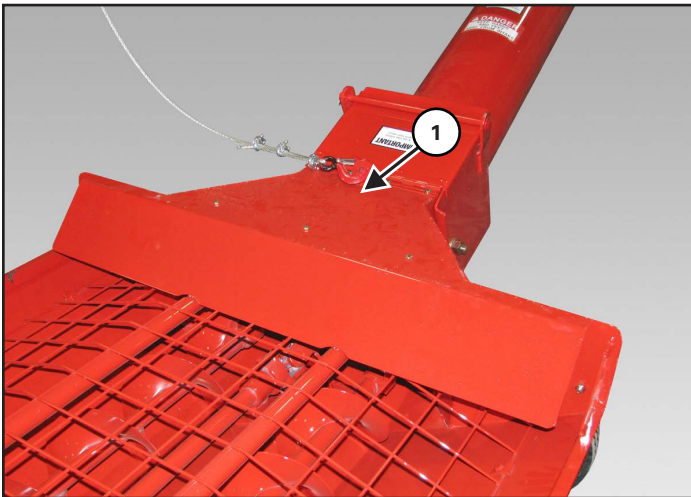

Remove the lift boom / winch cable hook (Item 1) from the hopper **[Figure 19]**.

Move the hopper to the desired location.

Figure 20

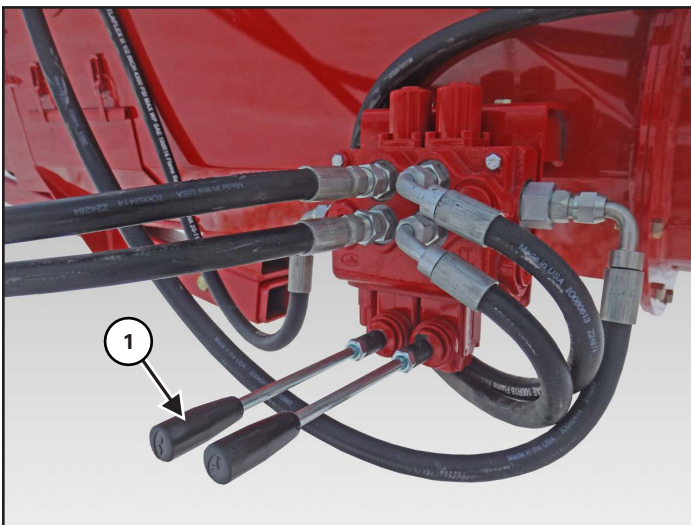

Hopper Mover: Move the lever (Item 1) down to move the hopper to the right. Move the lever up to move the hopper to the left **[Figure 20]**.

Main Lift Cylinder Adjust

Figure 21

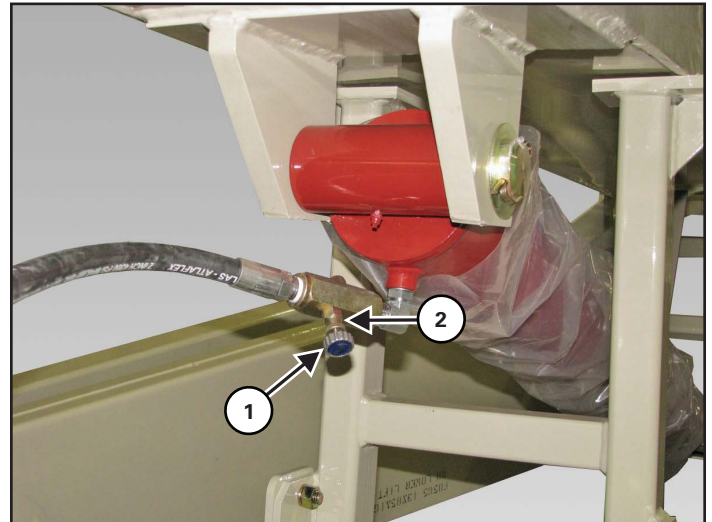

Turn the knob (Item 1) on the flow control valve "IN" to decrease the speed the auger lowers. Turn the knob "OUT" to increase the speed the auger lowers **[Figure 21]**.

Loosen the nut (Item 2) and turn the knob all the way in (tight). The approximate initial setting should be 3-1/2 turns out from the tight position. When set, re-tighten nut to set position **[Figure 21]**.

NOTE: Be sure that the valve is slightly open before raising the first time or auger will not lower.

Auger Placement



ELECTROCUTION HAZARD

To prevent serious injury or death from electrocution:

- Be aware of overhead power lines.
- Keep away from power lines when unloading and assembling the auger.
- Electrocution can occur without direct contact.



Do not operate the unit before reading and understanding the Operator Manual.

Keep all safety devices in place.

Keep off the equipment at all times.

Keep hands, feet and clothing away from moving parts while in operation.

Make certain everyone is clear of the equipment before applying power or moving the machine.

Do not adjust, service, lubricate, clean, unclog or move the mechanism until all power is shut off.

While in operation, always support the discharge end or provide adequate anchoring of the intake end to prevent sudden tipping.

Disconnect power of electrical driven units before resetting motor overloads.

To avoid tipping, make sure auger is empty before attempting to move.

Keep wheels of undercarriage level and on firm ground.

Lower unit to the recommended transport position before transporting.



Do not raise the main auger higher than 35° before lowering the intake auger or interference between the intake auger and the intake box will occur.

Never attempt to raise or lower the auger during operation.

Verify wheels are free to move.

Operate the auger at a 35° angle. Do not exceed a 42° angle. Angles above 35° decrease auger capacity.

Some types of fertilizer may cause accelerated wear and corrosion as well as added stress on lift components due to additional load. Use of fertilizer may affect warranty.

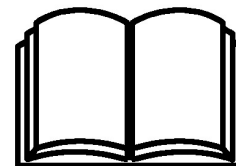

Follow the instructions in your tractor's operation manual for the correct operating instructions.

With the main auger in the fully down position, move the auger towards the bin or barn. Position the auger as close as possible to the bin or barn.



Never place blocks under the wheels to increase the elevation of the auger.

Stop the tractor and engage the parking brake. Engage the tractor's hydraulics. Run the tractor engine at low idle.

Figure 22

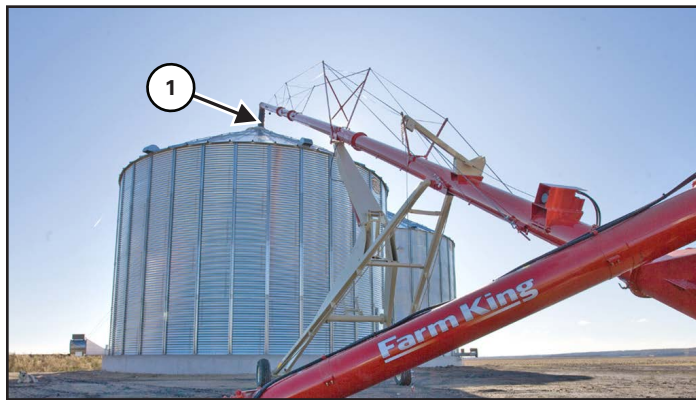

Using the tractor controls, slowly raise the main auger to the desired height (do not exceed a 42° angle).



Keep wheels of undercarriage level and on firm ground. Raise the auger to the desired height and back the auger into position. Do not support the auger on the bin. As the auger becomes full, the weight may cause damage to the underside of the auger or to the bin.

Back the auger into position above the bin. Lower the auger until the downspout (Item 1) enters the bin [Figure 22].

Engage the tractor's parking brake, stop the engine and exit the tractor.

Unloading Belly Dump Units

Figure 23

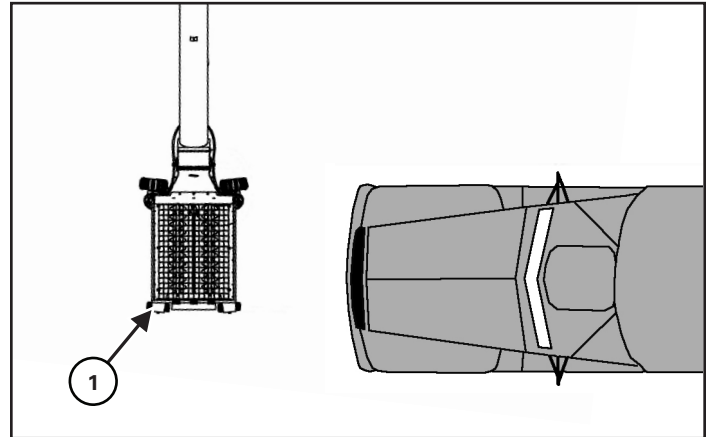

Move the hopper (Item 1) out at a 90° angle from the auger [Figure 23].

Move the belly dump unit into position, centered on the hopper.

Mark the path of the belly dump unit for future units to unload and maintain the proper distance from the auger to allow adequate space for the hopper to be moved in and out without interference.

Move the hopper mover lever left or right to move the hopper in towards the auger, away from vehicle traffic.

Figure 24

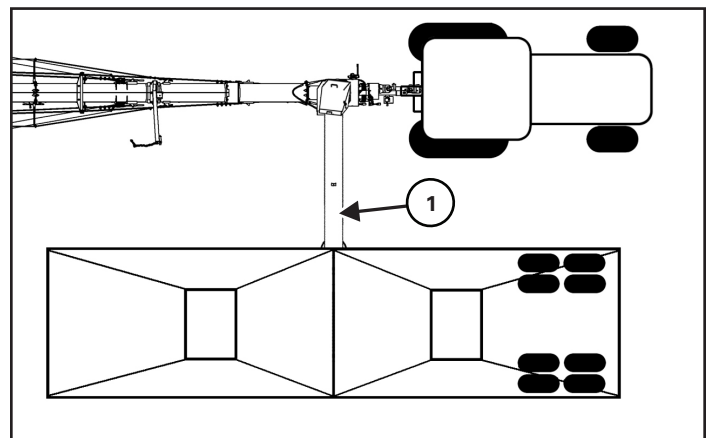

Move the belly dump unit straight forward until centered on the intake auger pivot. Stop the belly dump unit.

Move the hopper (Item 1) under the belly dump unit [Figure 24].

Figure 25

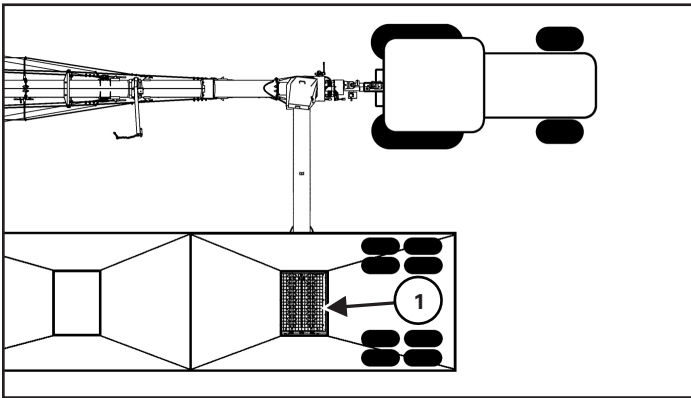

Move the belly dump unit forward until the rear compartment is directly over the hopper (Item 1) [Figure 25].



AVOID INJURY OR DEATH

Do NOT exceed 540 RPM PTO if equipped with chain drive.

Do NOT exceed 1000 RPM PTO if equipped with optional M1000 gearbox.

Keep PTO shields and all guards in place.

Keep away from moving parts.

Keep bystanders away.

With tractor running at a low idle, engage the tractor PTO slowly to start the auger. Increase engine RPM (do not exceed 540 RPM PTO speed / M1000 Option is 1000 RPM).

Slowly open the compartment gate.

Adjust gate until the hopper augers and intake auger can move grain to the main auger without overflowing the hopper.

When the rear compartment is empty, close the gate, disengage the PTO and lower engine RPM speed.

Figure 26

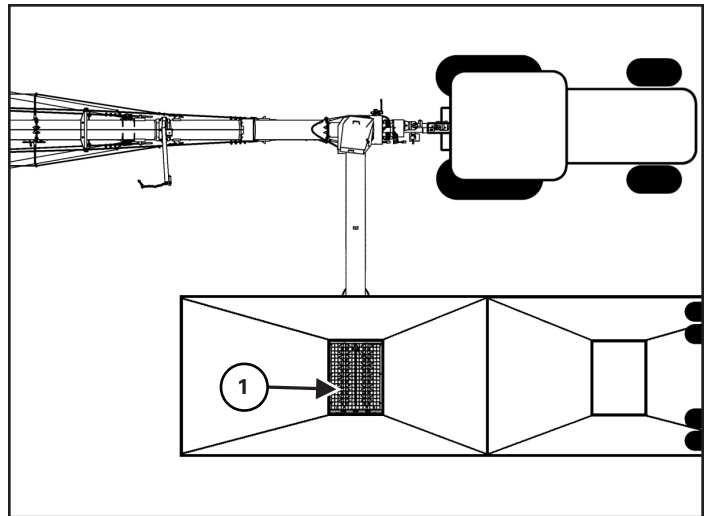

Move the belly dump unit back until the front compartment is directly over the hopper (Item 1) [Figure 26].

With tractor running at a low idle, engage the tractor PTO slowly to start the auger. Increase engine RPM (do not exceed 540 RPM PTO speed / M1000 Option is 1000 RPM).

Slowly open the compartment gate.

Adjust gate until the hopper augers and intake auger can move grain to the main auger without overflowing the hopper.

When the front compartment is empty, close the gate, disengage the PTO and lower engine RPM speed.

Move the hopper in the desired position away from vehicle traffic.

Disengage the tractor hydraulics and exit the tractor.

Unloading Rear And Side Dump Units

Figure 27

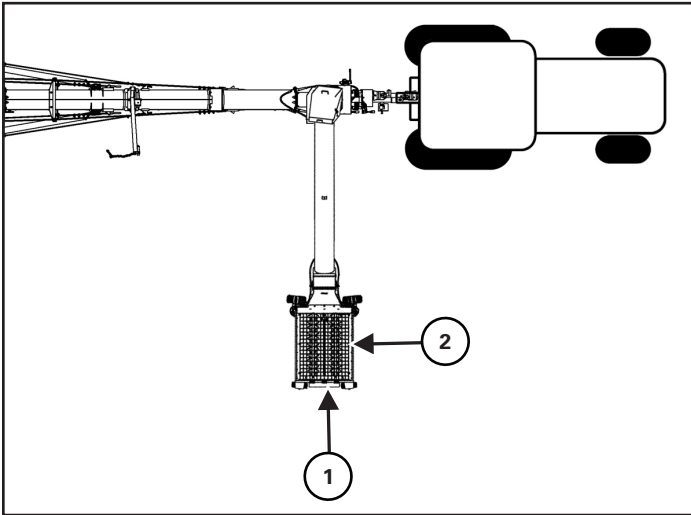

Move the hopper out at a 90° angle from the auger.

Move the rear dump unit into the unloading position at the end of the hopper (Item 1) or on the tractor side of the hopper (Item 2) [Figure 27].

Move the side dump unit into the unloading position at the end of the hopper (Item 1) [Figure 27].

Position the gate of the dumping unit over the hopper (as close to the center of the hopper as possible).

Stop the dumping unit and engage the parking brake (if equipped).



AVOID INJURY OR DEATH

Do NOT exceed 540 RPM PTO if equipped with chain drive.

Do NOT exceed 1000 RPM PTO if equipped with optional M1000 gearbox.

Keep PTO shields and all guards in place.

Keep away from moving parts.

Keep bystanders away.

With tractor running at a low idle, engage the tractor PTO slowly to start the auger. Increase engine RPM (do not exceed 540 RPM PTO speed / M1000 Option is 1000 RPM).

Slowly open the gate on the dumping unit.

Adjust gate until the hopper augers and intake auger can move grain to the main auger without overflowing the hopper.

When the unit is empty, close the gate, disengage the PTO and lower engine RPM speed.

Disengage the tractor hydraulics and exit the tractor.

TRANSPORTATION

Requirements



ELECTROCUTION HAZARD

To prevent serious injury or death from electrocution:

- Be aware of overhead power lines.
- Keep away from power lines when transporting the auger.
- Electrocution can occur without direct contact.



Use of an unapproved hitch or tractor / tow vehicle can result in loss of control, leading to serious injury or death. Tractor / tow vehicle and hitch must have the rated capacity to tow equipment.



Do not operate the unit before reading and understanding the Operator Manual.

Make certain everyone is clear of the equipment before applying power or moving the machine.

To avoid tipping, make sure auger is empty before attempting to move.

Keep wheels of undercarriage level and on firm ground.

Lower unit to the recommended transport position before transporting.

Disconnect PTO driveline from the tractor before moving or transporting.



Never exceed 20 mph (32 kph).

Do not move or transport the auger unless the hopper and intake auger are in the raised / transport position and securely fastened before transporting.

Comply with federal, state, local and provincial laws regarding the transport of farm equipment on public roadways.

Verify that the tractor / tow vehicle are approved for transporting the equipment and that the equipment is securely attached to the tractor / tow vehicle.

Verify safety chain is installed and properly connected before transporting equipment.

Verify that the SMV (Slow Moving Vehicle) emblem, all lights and reflectors are clean and visible.

Always attach a red flag to the end of the auger when transporting on roads.

Disconnect the PTO driveline from the tractor before transporting.

Transporting Guidelines

The ratio of the tractor / tow vehicle weight to the loaded equipment weight plays an important role in defining acceptable travel speed.

Travel speed: Acceptable travel speed.

Weight ratio: Weight of fully equipped or loaded implement(s) relative to weight of tractor / tow vehicle.

TRAVEL SPEED	WEIGHT RATIO
Up to 20 mph (32 kph)	1 to 1 (or less)
Up to 10 mph (16 kph)	2 to 1 (or less)
DO NOT TOW	More than 2 to 1

Transporting Procedure

Remove all supports on the discharge end and anchoring from the intake end (if required).

Figure 28

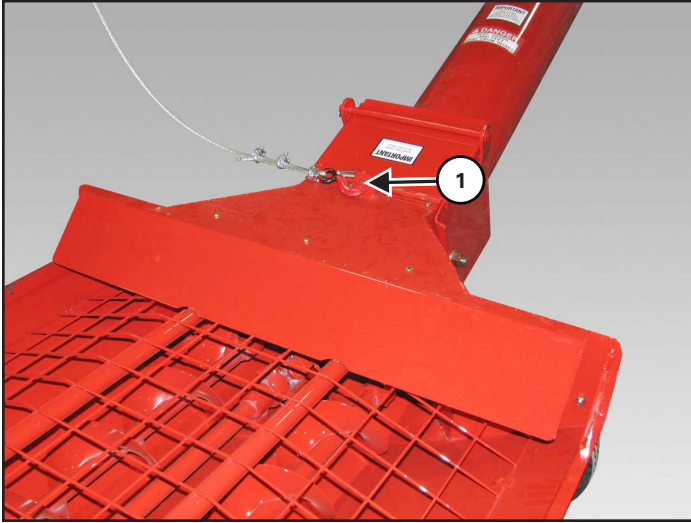

Use the hydraulic controls or mechanical winch to move the hopper toward the auger and install the boom cable (Item 1) [Figure 28].

Figure 29

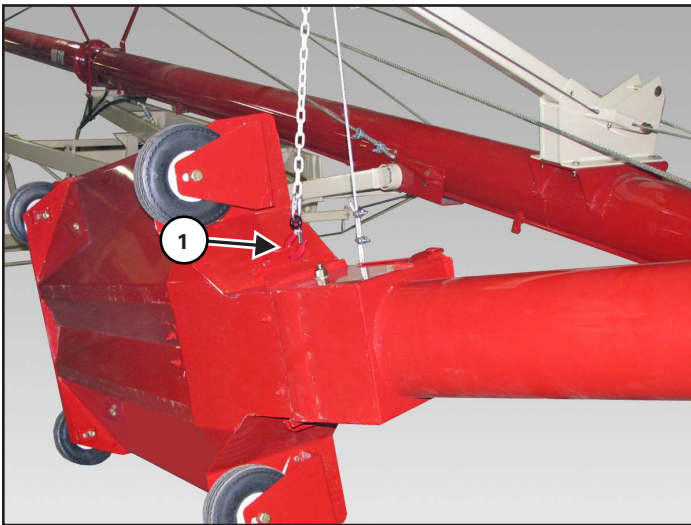

Use the hydraulic controls or mechanical winch to raise the hopper high enough to install the transport chain (Item 1) [Figure 29].

WARNING

The weight of the hopper and intake auger assembly must be supported by the transport chain whenever the auger is moved. If the weight of the intake auger is on the winch, the winch may be damaged during transport.

Lower the hopper until the transport chain is supporting the weight of the hopper and intake auger.

Enter the tractor, using the tractor controls, slowly raise the main auger until the discharge spout is clear from the bin.

Release the parking brake and move the tractor and auger forward (away from the bin) until there is adequate space for the auger to be lowered into the transport position.

Stop the tractor and engage the parking brake.

Figure 30

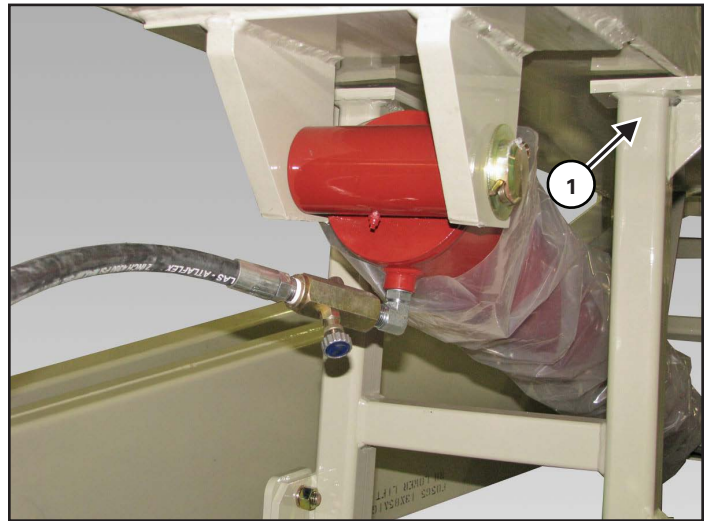

Fully lower the auger until the upper lift arm contacts the cradle rest (Item 1) [Figure 30].



WARNING

AVOID INJURY OR DEATH

Before you leave the operator's position:

- Always park on a flat level surface.
- Place all controls in NEUTRAL.
- Engage the park brake.
- Stop the engine and remove the key.
- Wait for all moving parts to stop.

Engage the tractor's parking brake, stop the engine and exit the tractor.

Figure 31

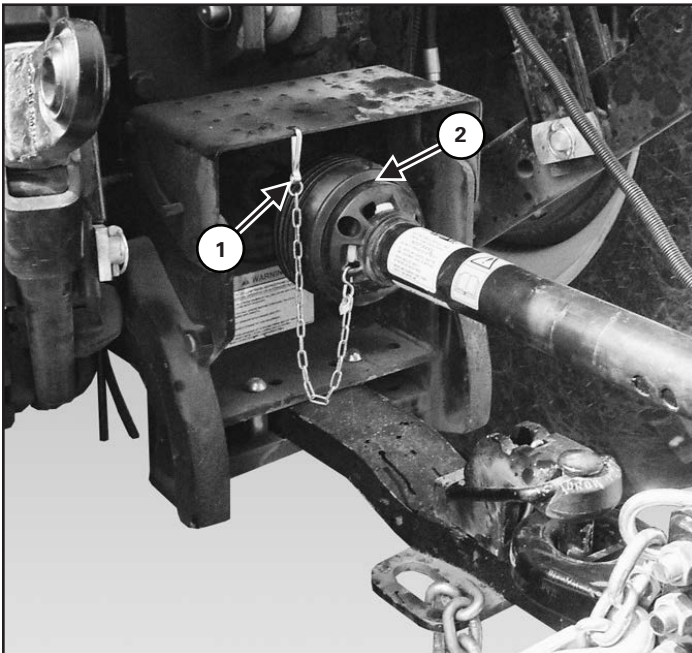

Remove the PTO driveline safety chain (Item 1). Retract the collar (Item 2) and slide the PTO driveline off the tractor PTO shaft [Figure 31].

Figure 32

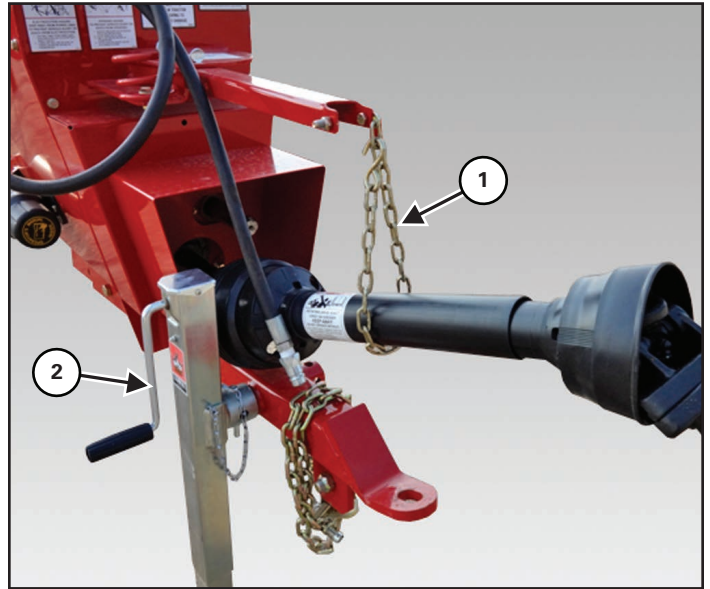

Place the PTO holder chain (Item 1) around the PTO driveline [Figure 32].

Fully raise the jack (Item 2) and rotate into the transport position (horizontal) [Figure 32].

Verify that the auger is securely fastened to the tractor / tow vehicle and that the hitch safety chain is properly attached to the auger and tractor / tow vehicle.

Verify that the SMV (Slow Moving Vehicle) sign is attached and visible.

Verify that the amber lights are clean and operating correctly.

Farm King



MAINTENANCE

TRUBLESHOOTING.....	45
SERVICE SCHEDULE.....	46
LUBRICATION.....	47
Recommendations.....	47
Locations.....	47
AXLES.....	51
Wheel Lug Nut Torque.....	51
Tire / Wheel Replacement.....	51
Tire Pressure.....	51
BRIDGING CABLES.....	52
Cable Inspection.....	52
Lubrication.....	52
Cleaning.....	52
Tension Adjust.....	52
STORAGE AND RETURN TO SERVICE.....	54
Storage.....	54
Return To Service.....	54
SAFETY SIGN (DECAL) INSTALLATION.....	54
ELECTRIC HOPPER CONTROL BOX TROUBLESHOOTING.....	55
Hopper Will Not Move Left Or Right.....	55
Hopper Will Only Move In One Direction.....	55
Remote Control Functions Correctly But The Move-Left/Right Switches On The Box Do Not.....	55
Winch Will Not Raise Or Lower.....	56
Winch Will Only Rotate In One Direction.....	56
Remote Control Functions Correctly But The Raise/Lower Switches On The Box Do Not.....	56
ELECTRIC HOPPER REMOTE OPERATION.....	57
Operation.....	57
Recharging.....	57
Indicator Lights.....	57
Teach ID Code.....	57
PART IDENTIFICATION - CONTROL BOX SZ000997.....	58

Farm King



TROUBLESHOOTING

PROBLEM	CAUSE	CORRECTION
Cannot start augers.	Plugged auger or obstruction.	Shutoff tractor and disconnect the PTO. Remove obstruction.
	Bearing failure.	Check bearings and replace if required.
Grain flow is too fast.	Discharge gate(s) open too far.	Close the gate(s) to allow a slower grain flow to the hopper / intake auger.
Grain flow is too slow.	Discharge gate(s) not open enough.	Open the gate(s) to allow a faster grain flow to the hopper intake auger.
	Tractor RPM set to low.	Raise tractor RPM to proper setting.
Lights do not function.	Loose connection.	Check electrical connection at tractor.
	Faulty harness or wire.	Check for broken wires.
	Faulty tractor circuit.	Check tractor light circuit.

NOTE: If a problem is encountered that is difficult to solve, even after having read through this troubleshooting section, please call your local Farm King dealer. Before you call, please have this Operator And Parts Manual and the serial number of your machine at hand.

SERVICE SCHEDULE

Maintenance work must be done at regular intervals. Failure to do so will result in excessive wear and early failures. The service schedule is a guide for correct maintenance of the equipment.



WARNING

Instructions are necessary before operating or servicing equipment. Read and understand the Operator and Parts Manual and safety signs (decals) on equipment. Follow warnings and instructions in the manuals when making repairs, adjustments or servicing. Check for correct function after adjustments, repairs or service. Untrained operators and failure to follow instructions can cause injury or death.

#	DESCRIPTION	SERVICE PROCEDURES					
		Check	Clean	Lube	Change	Adjust	Drain
Daily Maintenance (or every 8 hours)							
1	CV Joints, U-Joints and Bearings			•			
2	PTO Driveline			•			
3	Universal Joint (Front)			•			
4	Lower & Upper Lift Arm Pivots			•			
5	Hopper Drive Shaft & U-Joints			•			
6	Intake Auger Shaft & U-Joints			•			
7	Dual Auger Hopper Drive Chains			•			
Weekly (or every 50 hours)							
8	Lower Intake Auger Gearbox Oil Level	•					
9	Upper Intake Auger Gearbox Oil Level	•					
10	Main Gearbox	•					
11	Wheel Lug Nut Torque	•					
12	Winch Cable	•					
13	Bridging Cable Tension	•					
Semi-Annually (or every 250 hours)							
14	Bridging Cables	•	•			•	
15	Backsaver Auger		•				
Annually (or every 500 hours)							
16	Lower Intake Auger Gearbox Oil				•		
17	Upper Intake Auger Gearbox Oil				•		
18	Main Gearbox				•		
19	Main Tubes	•					

LUBRICATION

Recommendations

Always use a good quality multi-purpose / lithium base grease when lubricating the equipment.

- Always use a hand-held grease gun.
- Clean fitting before greasing, to avoid injecting dirt and grit.
- Replace and repair broken fittings immediately.
- If fittings will not take grease, remove and clean thoroughly. Replace fitting if necessary.



Fluid such as engine oil, hydraulic fluid, coolants, grease, etc. must be disposed of in an environmentally safe manner. Some regulations require that certain spills and leaks on the ground must be cleaned in a specific manner. See local, state and federal regulations for the correct disposal.

Locations

Lubricate the following grease locations EVERY 8 HOURS:

Figure 33

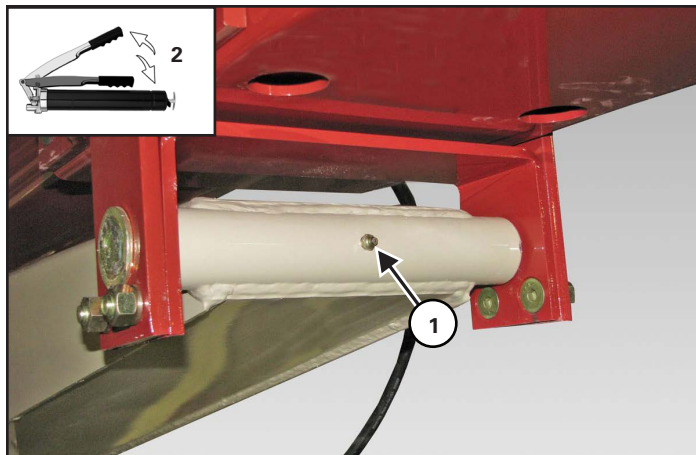

Apply two pumps of grease to the (Item 1) [Figure 33].

Lubricate the following grease locations EVERY 50 HOURS:

NOTE: The PTO shaft is equipped with extended life bearings. Do not over-grease.

Figure 34

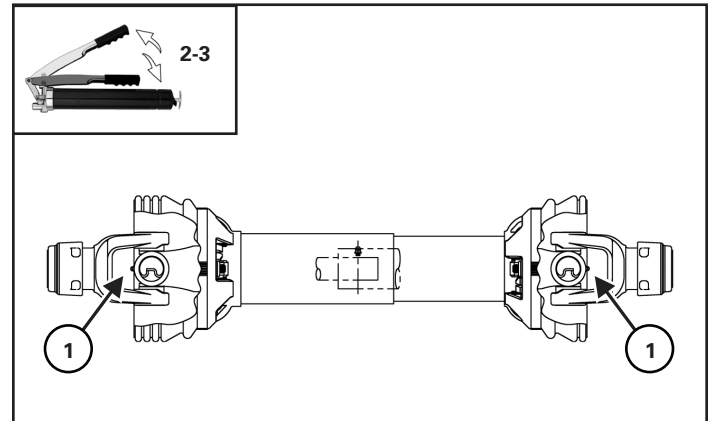

Apply two to three pumps of grease to the cross and bearings (Item 1) on the PTO driveline [Figure 34].

Figure 35

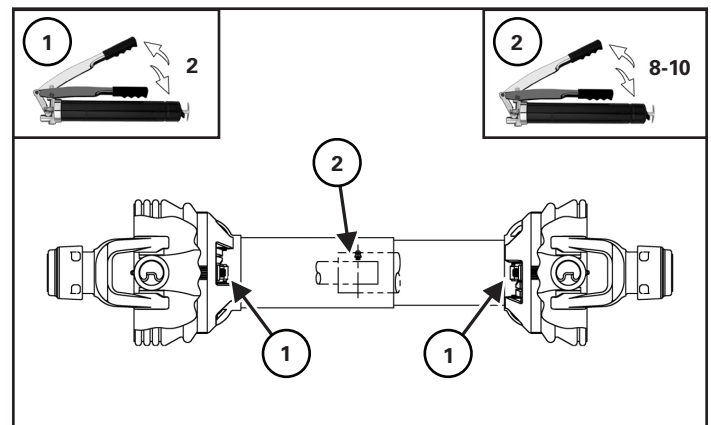

Apply two pumps of grease to the guard bushings (Item 1) [Figure 35].

Apply eight to ten pumps of grease to the telescoping member (Item 2) [Figure 35].

Figure 36

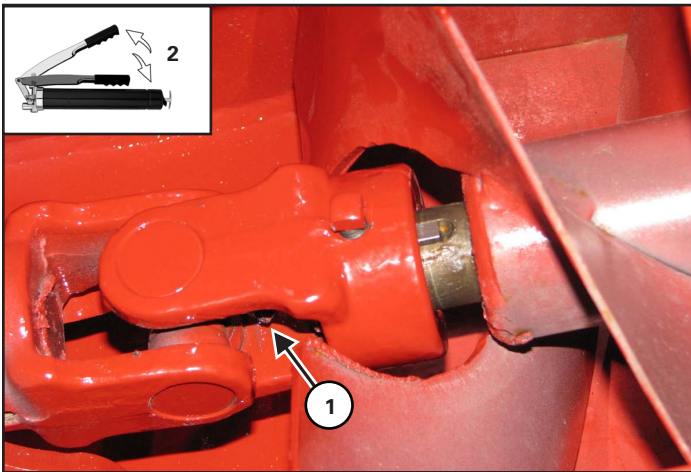

Apply two pumps of grease to the universal joint (Item 1) on the hopper auger drive shaft [Figure 36].

Figure 37

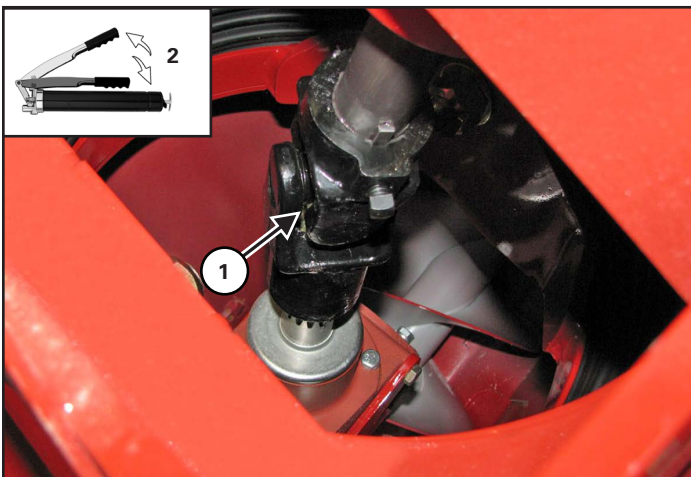

Apply two pumps of grease to the intake drive shaft side (Item 1) [Figure 37].

Figure 38

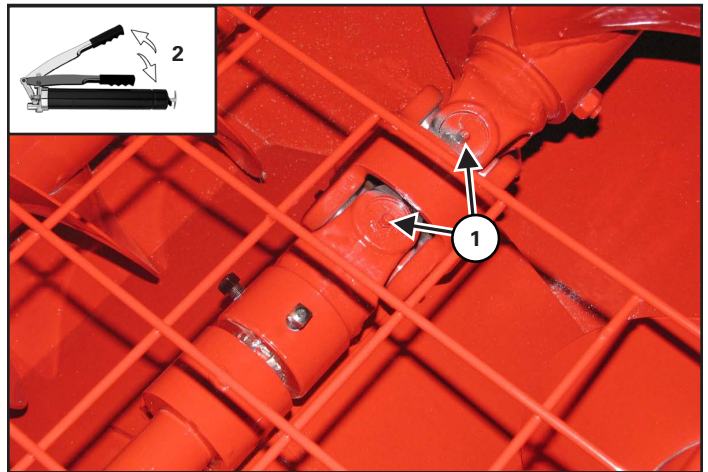

Apply two pumps of grease to the intake hopper drive shaft (Item 1) [Figure 38].

Figure 39

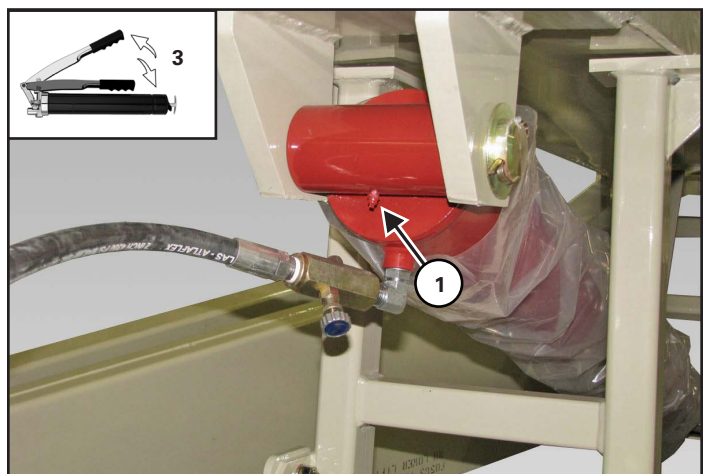

Apply three pumps of grease to the base end of the lift cylinder (Item 1) [Figure 39].

Figure 40

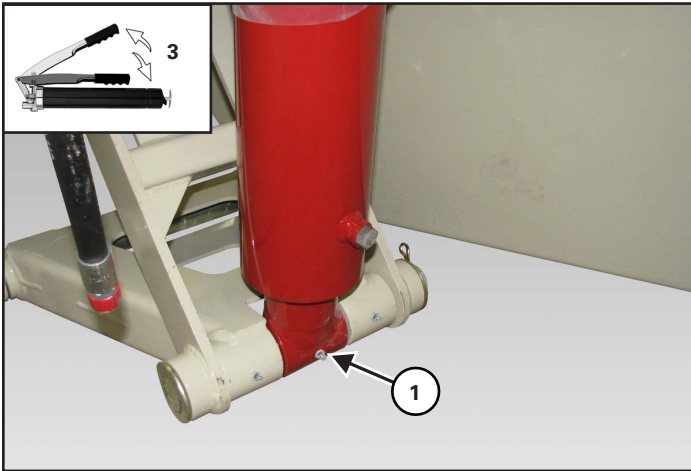

Apply three pumps of grease to the rod end of the lift cylinder (Item 1) [Figure 40].

Figure 41

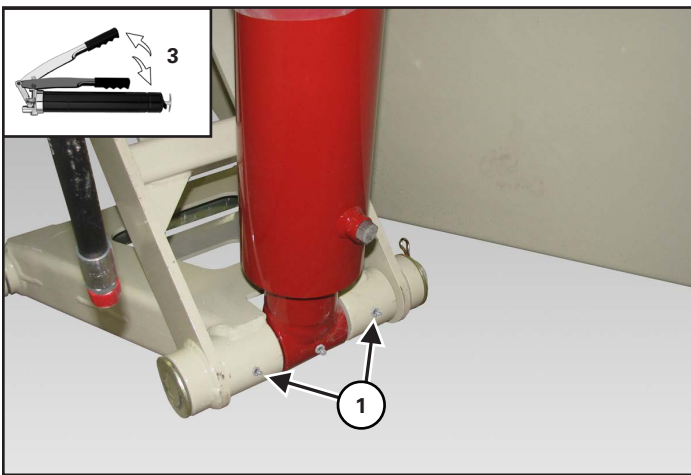

Apply three pumps of grease to the connecting link (Item 1) [Figure 41].

Figure 42

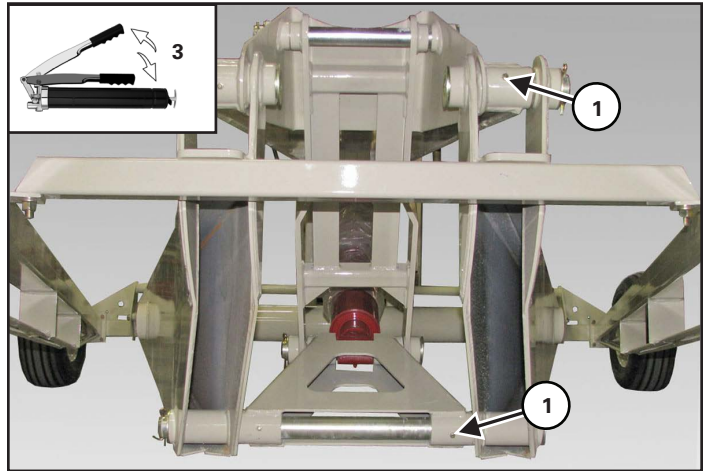

Apply three pumps of grease to the LH & RH lower lift arms (Item 1) [Figure 42].

Figure 43

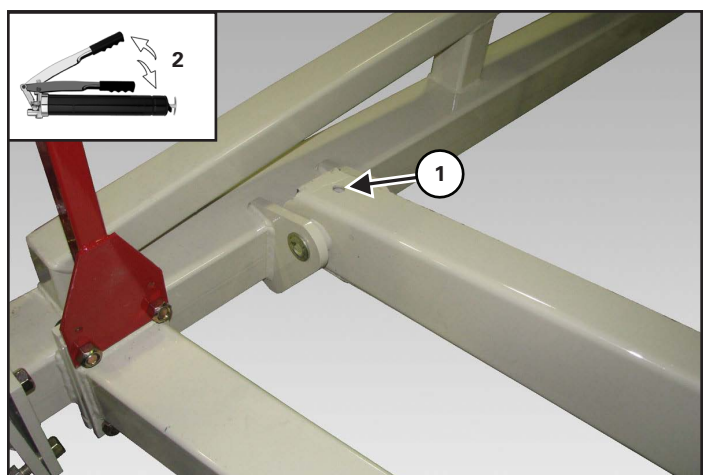

Apply two pumps of grease to the RH lower lift arm pivot (Item 1). Repeat procedure on the LH lower lift arm pivot [Figure 43].

Lubricate the following grease locations EVERY 8 HOURS:

Figure 44

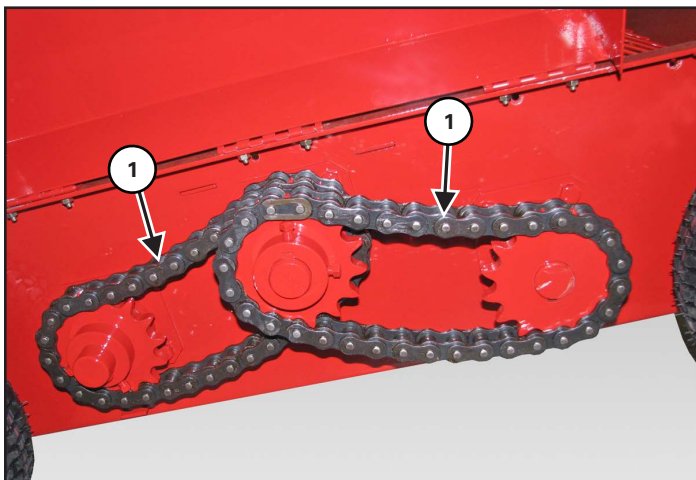

Apply oil to the dual auger drive chains (Item 1) [Figure 44].

Check the upper gearbox oil level every 50 hours:

Figure 45

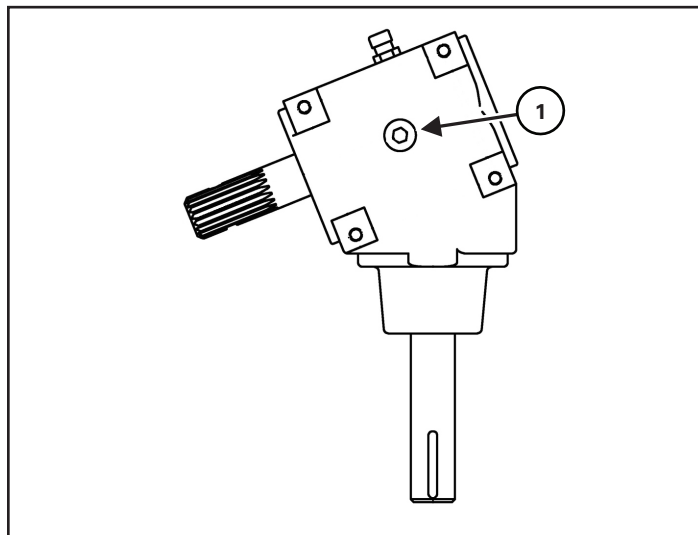

Remove the fill / drain plug (Item 1) from the gearbox. Oil level should be at the bottom of the plug hole [Figure 45].

If the oil level is low, add SAE 75W-90 synthetic gear oil until the oil is at the bottom of the hole.

Changing Gear Oil

Remove the fill / drain plug (Item 1) and siphon all the gear oil from the gearbox [Figure 45].

Fill with SAE 75W-90 synthetic gear oil to the bottom of the plug hole. Install fill / drain plug.

Cleaning And Inspection

NOTE: Inspect the driveline components, replace all damaged or worn components.

Use solvent to clean the shaft and tube. Use compressed air to dry and remove excess solvent from the parts.

Apply a light coat of grease to the shaft and the tube end.

Use solvent to clean the slide collars, yokes, crosses and bearings. Use compressed air to dry the parts.

Apply a light coat of grease to the inside of the slide collars.

AXLES

Wheel Lug Nut Torque

Check the torque on wheel lug nuts daily. Tighten lug nuts to 120 ft.-lbs. (162 N•m) torque.

Tire / Wheel Replacement

Empty the Backsaver Auger (if required).



WARNING

AVOID INJURY OR DEATH

Before you leave the operator’s position:

- Always park on a flat level surface.
- Place all controls in NEUTRAL.
- Engage the park brake.
- Stop the engine and remove the key.
- Wait for all moving parts to stop.

Park the tractor / equipment on a flat level surface.

Place all controls in neutral, engage the park brake, stop the engine and wait for all moving parts to stop. Leave the operator’s position.

Place chock blocks behind and in front the auger tire.

Place a jack under the axle frame on the side the wheel is to be replaced. Raise the jack until the wheel is slightly off the ground.

NOTE: Place blocks under the frame to help secure the auger when wheel is raised off the ground.

Figure 46

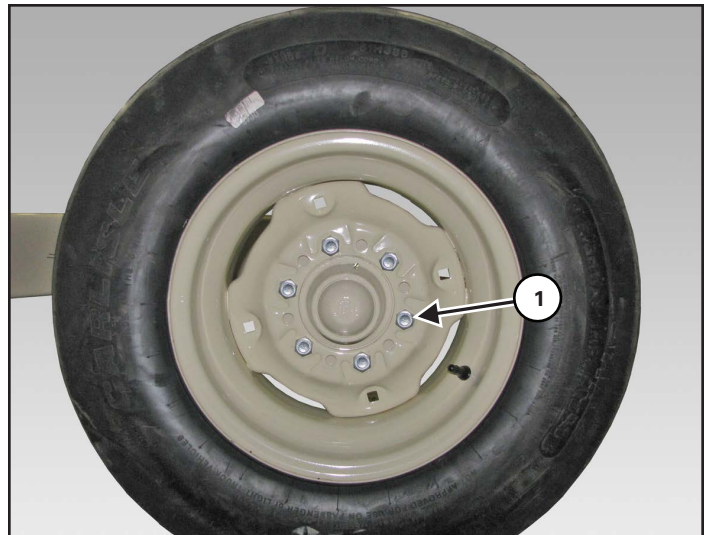

Install the tire with the valve stem facing out (both sides). Install the six wheel bolts (Item 1) (both sides) [Figure 46].

Tighten wheel nuts in a criss-cross pattern. Tighten wheel nuts to 120 ft.-lbs. (162 N•m) of torque.

Lower the axle and tires to the ground. Remove the strap and lifting device.

Tire Pressure

Recommended tire pressure is 45–50 PSI (310–345 kPa). Maximum tire pressure of 60 PSI (415 kPa).



CAUTION



When inflating tires, use a clip-on chuck and extension hose long enough to allow you to stand to one side and NOT in front of or over the tire assembly.

BRIDGING CABLES

Cable Inspection



IMPORTANT

Always wear the proper hand and eye protection when serving the equipment.

Regularly check the tightness of all cable clamps to avoid slipping. Inspect cables regularly for damage, wear or corrosion.

Cable inspections should be done at the beginning of operation and directly after the auger has been towed or transported.

Use a piece of cloth or rag to slide across the cables to locate broken or frayed wires. Replace cables as needed.

Lubrication

To prevent damage by corrosion, the cables should be kept well lubricated.

Cleaning

Periodic cleaning of cables by using a stiff brush and kerosene or with compressed air or live steam and re-lubricating will help to lengthen cable life and reduce abrasion and wear on sheaves and drums.

Tension Adjust



IMPORTANT

Completely unload auger before adjusting bridging cables.

Figure 47

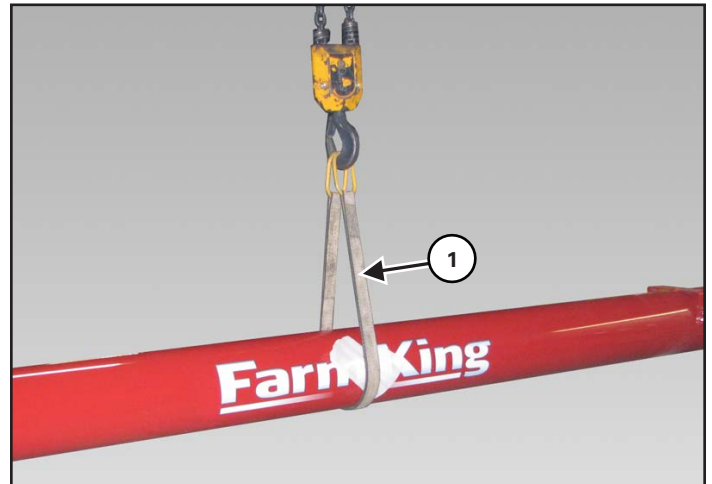

Install a strap (Item 1) around the tube [Figure 47].

Connect the strap to an approved lifting device.

Raise the lifting device, until tight, to support the auger tube(s).



WARNING

AVOID INJURY OR DEATH

Before you leave the operator's position:

- Always park on a flat level surface.
- Fully lower the main auger into the transport position.
- Disconnect the PTO driveline.
- Support the main auger tube with an approved lifting device.
- Chock tires.

Figure 48

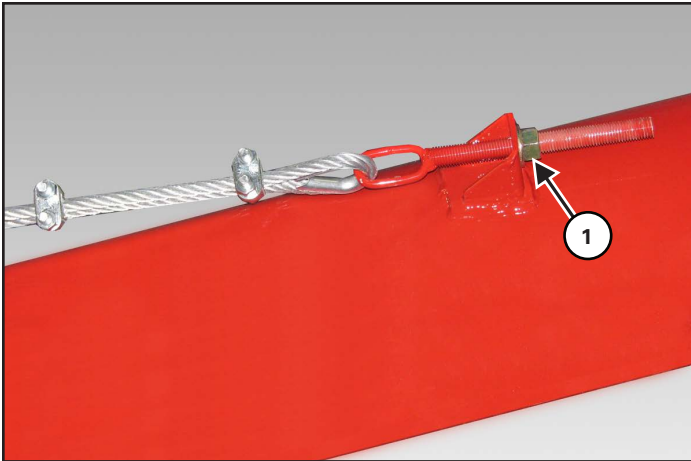

Loosen all cable clamps along the cable being tightened.

Tighten the nut (Item 1) of the desired bridging cable on tube **[Figure 48]**.

Tighten both left and right cables evenly.

Tighten the upper bridging cable until the discharge end of the tube bows up slightly.

Tighten the lower bridging cable to hold the tube in the slightly raised position.

After tightening the lower and upper cables, check that the auger tube is straight. No bend right or left.

NOTE: If the nut is fully tightened and bottoms out against the eye of the adjustment bolt, the cable will need to be loosened and additional adjustments will be made on the opposite end of the cable.

If the nut bottoms out against the eye of the adjustment bolt, loosen the nut (Item 1) **[Figure 48]**.

NOTE: Do not remove the nut from the adjustment bolt.

After adjusting the cable(s), tighten all cable clamps along the cable(s).

Figure 49

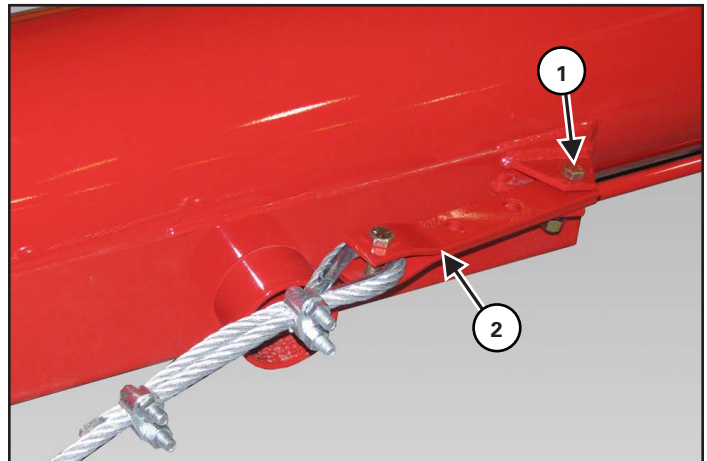

Remove bolt (Item 1) and lock nut (from mounting bracket on the bottom tube section), move the yoke (Item 2) back, one hole. Re-install the bolt and lock nut. Tighten until the yoke is securely fastened to the tube mount **[Figure 49]**.

Repeat for adjusting remaining bridging cables.

STORAGE AND RETURN TO SERVICE

Storage

Sometimes it may be necessary to store the equipment for an extended period of time. Below is a list of items to perform before storage.



IMPORTANT

DO NOT permit children to play on or around the stored machine.

- Thoroughly wash the machine with a pressure washer or water hose to remove all dirt, mud, debris or residue.
- Lubricate all bushings to remove any water residue from washing.
- Remove any material that has become entangled around any moving part.
- Inspect the hitch and all welds on the equipment for wear and damage.
- Check for loose hardware, missing guards, or damaged parts.
- Check for damaged or missing safety signs (decals). Replace if necessary.
- Replace worn or damaged parts.
- Touch up all paint nicks and scratches to prevent rusting.
- Place the equipment in a dry protected shelter.

NOTE: If a dry protected shelter is not available, cover with a waterproof tarp and tie down securely.

- Support the jack / frame with planks if required.

Return To Service

After the equipment has been in storage, it is necessary to follow a list of items to return the equipment to service.

- Be sure all shields and guards are in place.
- Lubricate the equipment.
- Connect to a tractor and operate equipment, verify all functions operate correctly.
- Check for leaks. Repair as needed.

SAFETY SIGN (DECAL) INSTALLATION



IMPORTANT

When replacing safety signs (decals), the temperature must be above 10° C (50° F).

- Remove all portions of the damaged safety sign (decal).
- Thoroughly clean the area with adhesive remover and glass cleaner. Remove all adhesive residue.
- Allow the area to dry completely before installing the new safety sign (decal).
- Position the safety sign (decal) in the correct location.
- Remove a small portion of the backing paper on the safety sign (decal).
- Press on the safety sign (decal) where the backing paper has been removed.
- Slowly remove the remaining backing paper, pressing on the safety sign (decal) as the backing paper is removed.
- Using the backing paper, pressing firmly, move the backing paper over the entire safety sign (decal) area.

NOTE: Small air pockets can be pierced with a pin and smoothed out using the piece of the backing paper.

ELECTRIC HOPPER CONTROL BOX TROUBLESHOOTING

Applies to all Units Equipped With Control Box SZ000997.



IMPORTANT

Check that wires and connectors are properly installed.

Check wires for damage.

Unplug system when not in use.

Hopper Will Not Move Left Or Right

Check that the circuit breaker (Item 1) is not deactivated. Push the button in to reset. This could be caused by defective motors or pinched wiring [Figure 50].

Check wiring for damage. Repair or replace damaged wiring.

Check that all motors are operating properly. Replace non-operational motor.

Hopper Will Only Move In One Direction

Disconnect the control box from the motors. Use a volts ohm meter to check the voltage at the drive wheel output wires.

There should be system voltage when pressing the left / right button on the control box. If there is voltage in both directions, the motor may be at fault and will need to be replaced.

If there is voltage in only one direction but not in the other, this is most likely a control relay failure (Item 2) [Figure 50].

Use the wire colors to determine the relay at fault:

- Green wire leads to the move-right relay
- White wire leads to the move-left relay

Replace defective relay.

Remote Control Functions Correctly But The Move-Left/Right Switches On The Box Do Not

Check the wires leading to the move-left and move-right switches (Item 3). Make sure the wires are connected properly [Figure 50].

Check wiring for damage. Repair or replace damaged wiring.

Figure 50

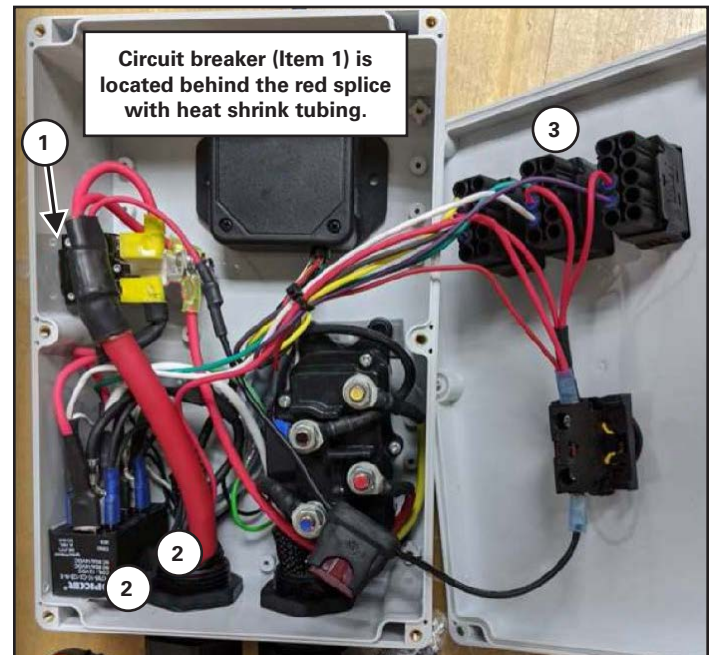

Winch Will Not Raise Or Lower

Check that the circuit breaker (Item 1) is not deactivated. Push the button in to reset. This could be caused by defective motors or pinched wiring [Figure 51].

Check wiring for damage. Repair or replace damaged wiring.

Check that the winch motor is operating properly. Replace non-operational motor.

Winch Will Only Rotate In One Direction

Disconnect the control box from the winch. Use a volts ohm meter to check the voltage at the winch output connection.

There should be system voltage when pressing the lift / lower button on the control box. If there is voltage in both directions, the motor may be at fault and will need to be replaced.

If there is voltage in only one direction but not in the other, this is most likely a control relay failure (Item 2) [Figure 51].

Use the wire colors to determine the relay at fault:

- Yellow wire leads to the winch-lower relay
- Brown wire leads to the winch-raise relay

Replace defective relay.

Remote Control Functions Correctly But The Raise/Lower Switches On The Box Do Not

Check the wires leading to the move-raise and move-lower switches (Item 3). Make sure the wires are connected properly [Figure 51].

Check wiring for damage. Repair or replace damaged wiring.

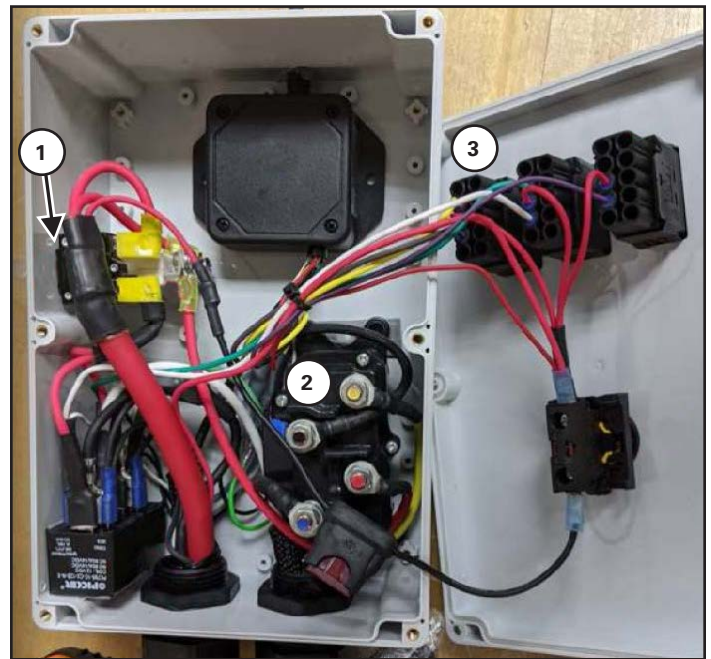
Figure 51

ELECTRIC HOPPER REMOTE OPERATION

Operation

Press and hold the power button on the transmitter until both LEDs turn on, then release.

The green LED will flash rapidly when communication has been established with the receiver. The green LED flashes slowly if the receiver is off or there is no communication between the transmitter and receiver.

Turn the receiver on and press the corresponding buttons on the transmitter keypad to turn on and off the LEFT, RIGHT, WINCH UP, WINCH DOWN outputs.

The only way to turn to turn off the LIGHT output early is to recycle power to the receiver with the transmitter off.

Recharging

The red BATTERY LED on the transmitter will blink once every second when the battery is low and requires charging.

Plug the charging connector into the port at the top of the transmitter. Observe orientation and do not use force.

A solid red LED indicates battery is charging. Once the internal battery is fully charged, the red LED will turn off and the green LED will turn on. A fully discharged unit will take up to 3 hours to recharge. Use only approved chargers.

Indicator Lights

The receiver has two LED indicators, the red ERROR CODE indicator and the green SIGNAL indicator.

The green SIGNAL indicator flashes rapidly whenever there is communication between the transmitter and the receiver.

The red ERROR CODE indicator starts blinking once every second when there is no RF communication between the receiver and transmitter. It also blinks when there is a problem with the system in the form of an error code. Refer to the ERROR CODE CHART table for more information.

Figure 52



Teach ID Code

To synchronize a new transmitter and receiver together use the following procedure:

1. Make sure both transmitter and receiver are off.
2. Press and hold the POWER button until both lights start to blink to put the transmitter into TEACH ID mode.
3. Release the POWER button.
4. Apply power to receiver.
5. Wait for 1 second or until the green and red LEDs on the transmitter stop blinking and green LED start blinking rapidly.

PART IDENTIFICATION - CONTROL BOX SZ000997

Figure 53



Figure 54



ITEM [Figure 53], [Figure 54]	PART NUMBER	DESCRIPTION	QTY.
1	931903	WIRE HARNESS	1
2	931904	30 AMP BREAKER	1
3	931905	70 AMP BREAKER	1
4	931906	60 AMP RELAY	2
5	931907	12V 160 AMP CONTACTOR	1
6	931908	2-POSITION SWITCH	1
7	931909	3-POSITION SWITCH	2
8	931910	LABEL	1
9	SZ001002	REMOTE	1
10	931911	RECEIVER	1
11	931912	E-STOP SWITCH	1

PARTS IDENTIFICATION

GENERAL PARTS INFORMATION.....	64
UNDERCARRIAGE - 70 MODELS.....	64
UNDERCARRIAGE - 85, 95 MODELS.....	66
UNDERCARRIAGE - 114 MODELS.....	68
STUB AXLE - 70 MODELS.....	70
STUB AXLE - 85, 95 MODELS.....	71
STUB AXLE - 114 MODELS.....	72
LIFT ARMS - 70 MODELS.....	74
LIFT ARMS - 85, 95 MODELS.....	76
LIFT ARMS - 114 MODELS.....	78
TUBES - 70 MODELS.....	80
TUBES - 85 MODELS.....	82
TUBES - 95 MODELS.....	86
TUBES - 114 MODELS.....	90
TUBE COMPONENTS - 70 MODELS.....	92
First Tube (Intake).....	92
Second Tube.....	92
Third Tube.....	93
TUBE COMPONENTS - 85 MODELS.....	94
First Tube (Intake).....	94
Second Tube.....	94
Third Tube.....	95
TUBE COMPONENTS - 95 MODELS.....	96
First Tube (Intake).....	96
Second Tube.....	96
Third Tube.....	97
Third Tube.....	98
TUBE COMPONENTS - 114 MODELS.....	99
First Tube (Intake).....	99
Second Tube.....	100

Third Tube.....	100
Fourth Tube.....	101
BRIDGING - 114 MODELS.....	102
INPUT BOX - 70, 85, 95 MODELS.....	104
INPUT BOX DRIVE - 70, 85, 95 MODELS.....	106
INPUT BOX - 114 MODELS.....	110
INPUT BOX DRIVE - 114 MODELS.....	112
IDLER.....	116
INPUT BOX M1000 - 70, 85, 95 MODELS.....	118
INPUT BOX M1000 DRIVE - 70, 85, 95 MODELS.....	120
INPUT BOX M1000 - 114 MODELS.....	122
INPUT BOX M1000 DRIVE - 114 MODELS.....	124
INTAKE AUGER.....	126
INTAKE AUGER FLIGHTING.....	128
SINGLE-FLIGHTING HOPPER.....	130
SINGLE-FLIGHTING HOPPER FLIGHTING.....	132
MULTI-FLIGHTING HOPPER.....	134
MULTI-FLIGHTING HOPPER FLIGHTING.....	136
PTO - 70, 85, 95 MODELS.....	138
PTO - 114 MODELS.....	140
PTO M1000 GEARBOX.....	142

Farm King



GENERAL PARTS INFORMATION

The parts identification section list descriptions, part numbers and quantities for all North America Base Model BS13 Series Augers. Contact your Farm King dealer for additional parts information.

UNDERCARRIAGE - 70 MODELS

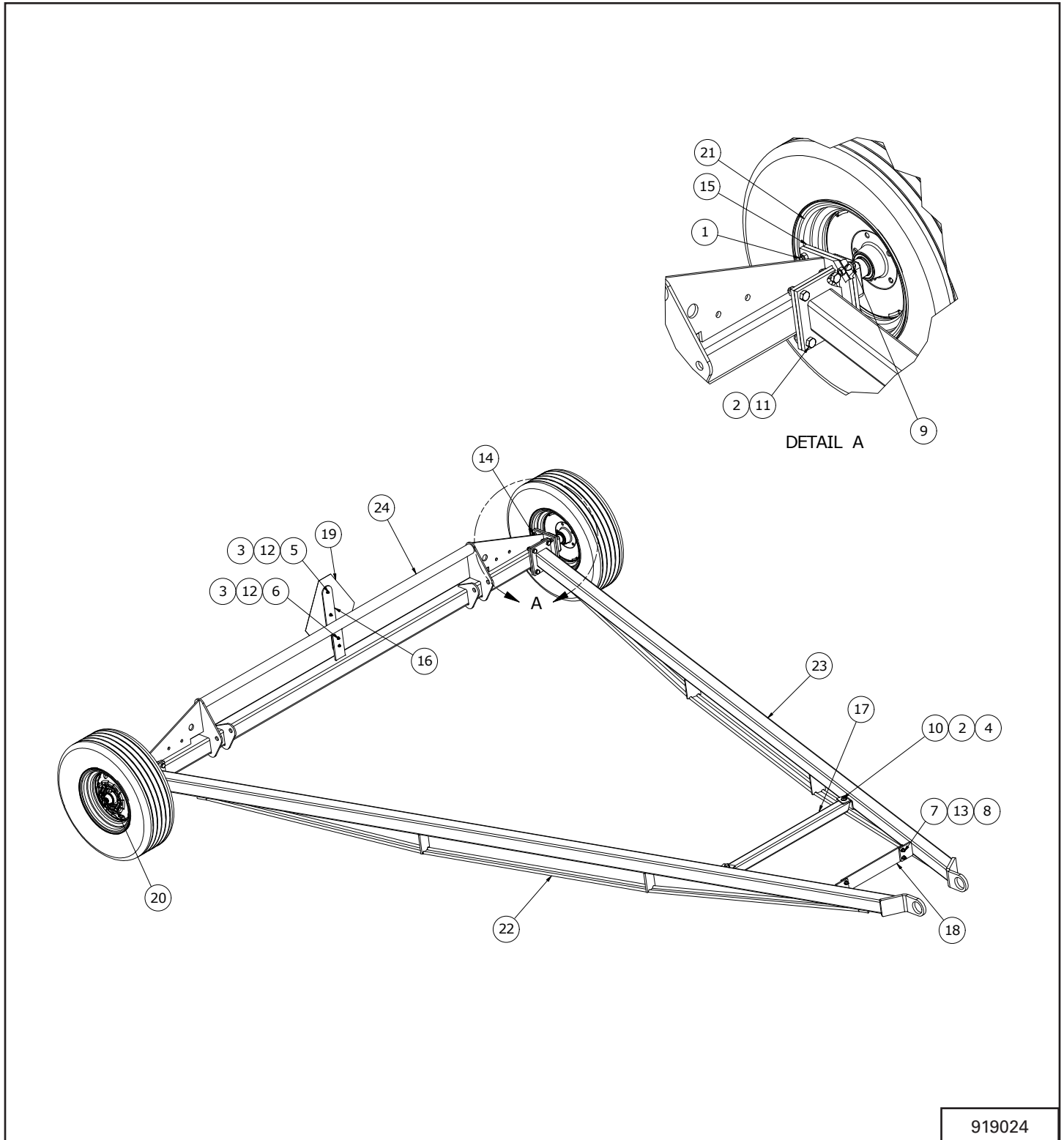

919024

ITEM	PART NUMBER	DESCRIPTION	QTY.
1	812364	1/2" LOCK NUT (PL)	8
2	812482	5/8" LOCK NUT (PL)	10
3	812624	1/4" FLAT WASHER PL	4
4	812639	WASHER 0.625 SAE FLAT BS PL	2
5	81525	1/4" X 3/4" HEX BOLT (PL)	2
6	81527	1/4" X 1" HEX BOLT (PL)	2
7	81599	7/16" X 1 1/2" HEX BOLT (PL)	4
8	84041	7/16" SAE FLAT WASHER (PL)	4
9	84048	1/2" SAE FLAT WASHER (PL)	8
10	84270	5/8" X 1 3/4" HEX BOLT (PL)	2
11	84299	5/8" X 2" HEX BOLT GR.5 (PL)	8
12	84498	1/4" LOCK NUT (PL)	4
13	86273	7/16" LOCK NUT (PL)	4
14	87553	1/2" X 1.75" HEX BOLT UNC GR5 (PL)	8
15	906572	ASSY-STUB AXLE 13"X70"	2
16	934486	BRKT-SMV MOUNT	1
17	960634	LIFT ARM CRADLE 3/16" X 2 1/2" X 2 1/2" X 40"	1
18	960699L	TIE PL 3/8 X 3 1/2 X 20"	1
19	967066	SLOW MOVING VEHICLE SIGN	1
20	968404	WHEEL BOLT 1/2" X 1 1/4" (PL)	12
21	F0210	WHEEL-15 X 6 X 6 BOLT	2
22	F1925	WELDT-RH UNDERCARRIAGE ARM	1
23	F1926	WELDT-LH UNDERCARRIAGE ARM	1
24	F1933	WELDT-BS1370 AXLE	1

UNDERCARRIAGE - 85, 95 MODELS

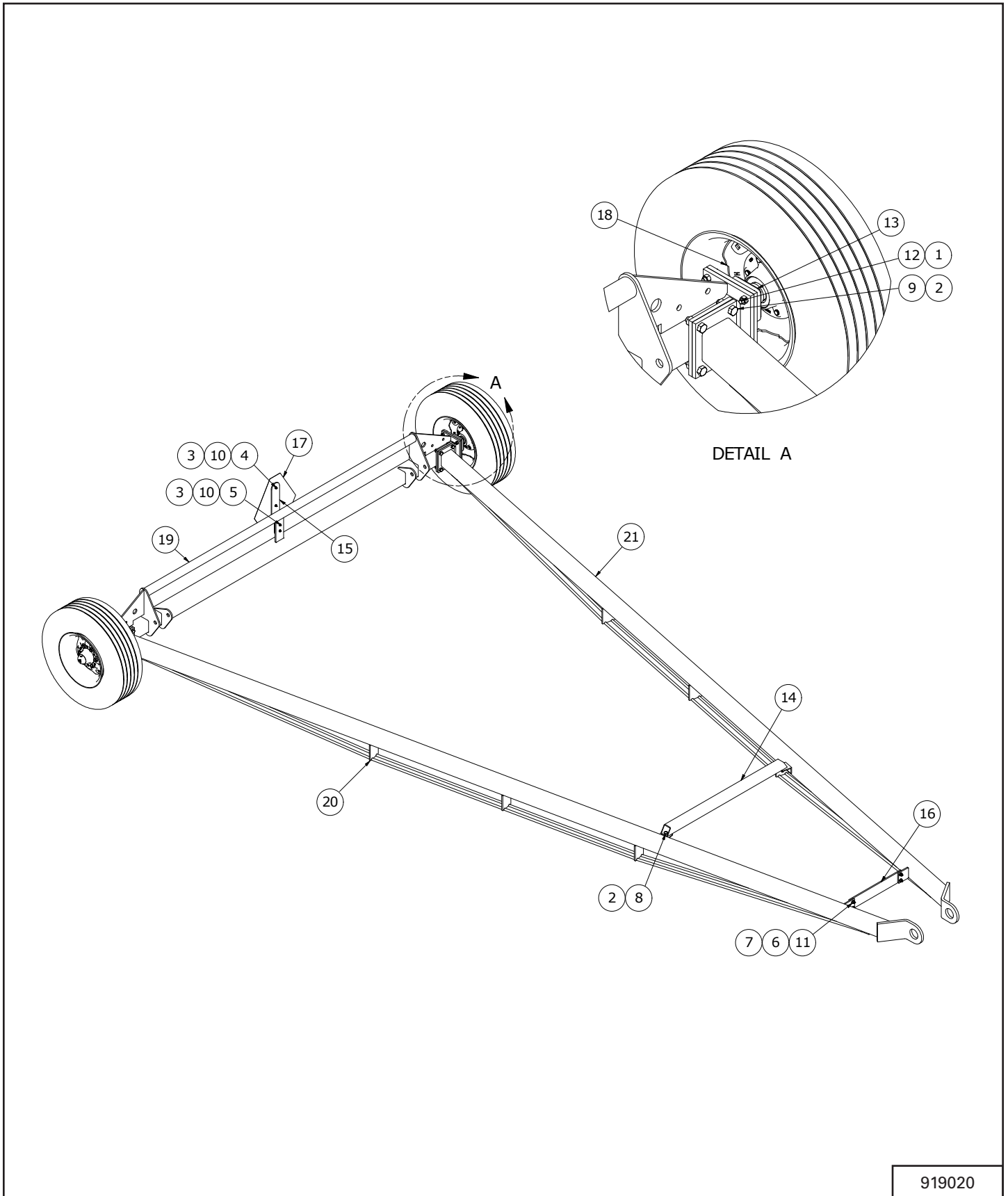

ITEM	PART NUMBER	DESCRIPTION	QTY.
1	812364	1/2" LOCK NUT (PL)	8
2	812482	5/8" LOCK NUT (PL)	10
3	812624	1/4" FLAT WASHER PL	4
4	81525	1/4" X 3/4" HEX BOLT (PL)	2
5	81527	1/4" X 1" HEX BOLT (PL)	2
6	81599	7/16" X 1 1/2" HEX BOLT (PL)	4
7	84041	7/16" SAE FLAT WASHER (PL)	4
8	84270	5/8" X 1 3/4" HEX BOLT (PL)	2
9	84299	5/8" X 2" HEX BOLT GR.5 (PL)	8
10	84498	1/4" LOCK NUT (PL)	4
11	86273	7/16" LOCK NUT (PL)	4
12	87553	1/2" X 1.75" HEX BOLT UNC GR5 (PL)	8
13	906573	STUB AXLE ASSEMBLY	2
14	919464	TUBE-UNDERCARRIAGE ARM BRACE	1
15	934486	BRKT-SMV MOUNT	1
16	960699L	TIE PL 3/8 X 3 1/2 X 20"	1
17	967066	SLOW MOVING VEHICLE SIGN	1
18	F0211	WHEEL-15 X 8 X 6 BOLT	2
19	F1460	AXLETUBE WELDT (134 1/2" LG)	1
20	F1480	RIGHT UNDERCARRIAGE ARM	1
21	F1481	LEFT UNDERCARRIAGE ARM	1

UNDERCARRIAGE - 114 MODELS

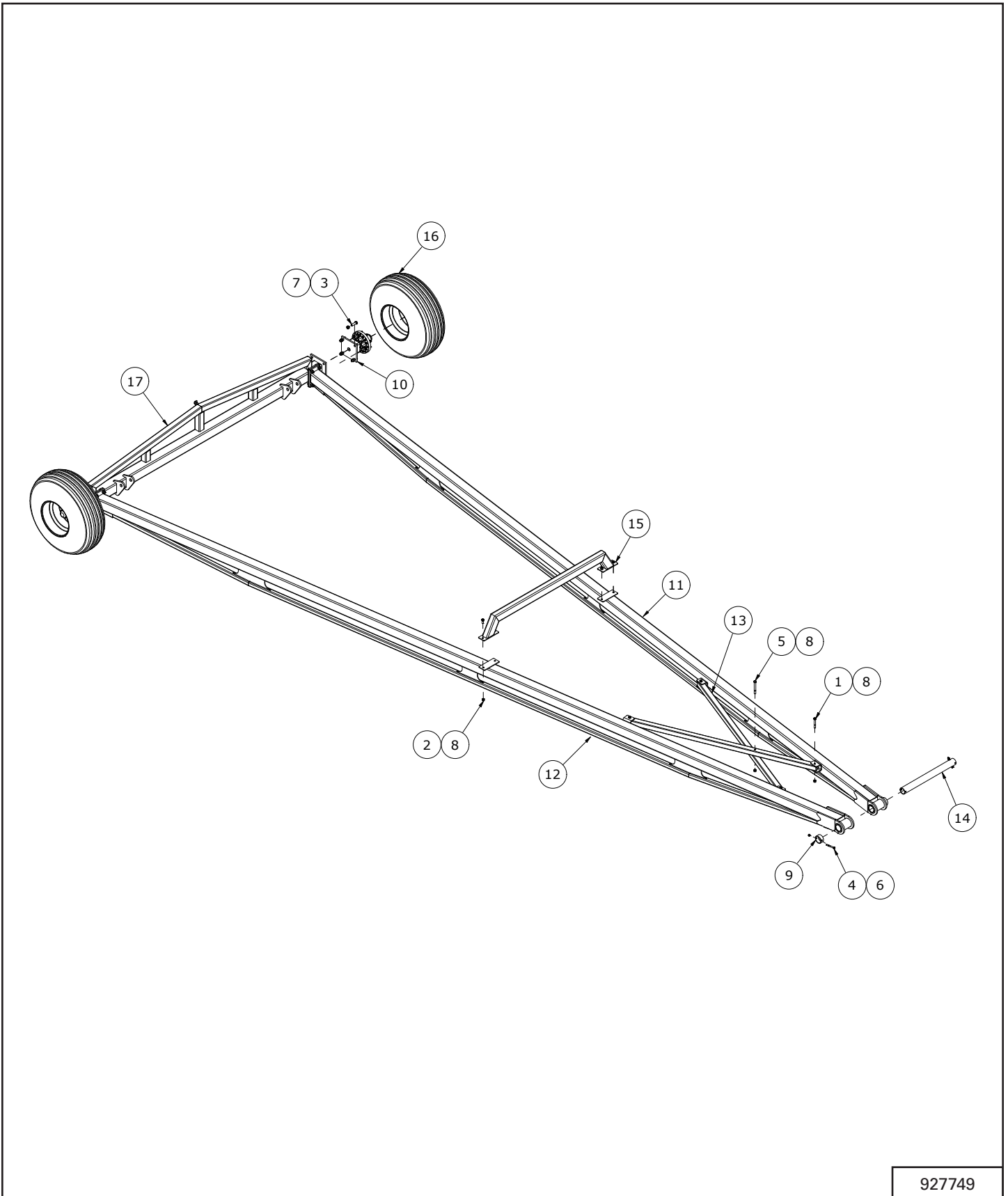

927749

ITEM	PART NUMBER	DESCRIPTION	QTY.
1	81672	SCR-HCS-GR5-(ZT)-5/8_11X4.5	4
2	84268	5/8" X 1 1/2" HEX BOLT (PL)	4
3	84346	3/4" X 2 1/2" HEX BOLT (PL)	16
4	811691	1/2" X 4 1/2" HEX BOLT (PL)	2
5	812087	5/8" X 6" HEX BOLT (PL)	1
6	812364	NUT-HEX-GR5-(ZT)-1/2_13	2
7	812365	3/4" LOCK NUT (PL)	16
8	812482	5/8" LOCK NUT GR5 (PL)	9
9	905736	UNDERCARR PIN SLEEVE 3 1/6"ID X 3 1/2"OD X 1 1/2"	2
10	909191	ASSY-STUB SHAFT AND HUB BS16104	2
11	927786	WELDT-LH UNDERCARRIAGE ARM	1
12	927787	WELDT-RH UNDERCARRIAGE ARM	1
13	927808	TUBE-CROSSBRACE	2
14	927811	TUBE-UNDERCARRIAGE PIN	1
15	928592	WELDT- LIFT ARM REST	1
16	F0679	TIRE AND WHEEL ASSY - BS 13114 & 16104	2
17	F2316	AXLE WELDMENT (16" BS)	1

STUB AXLE - 70 MODELS

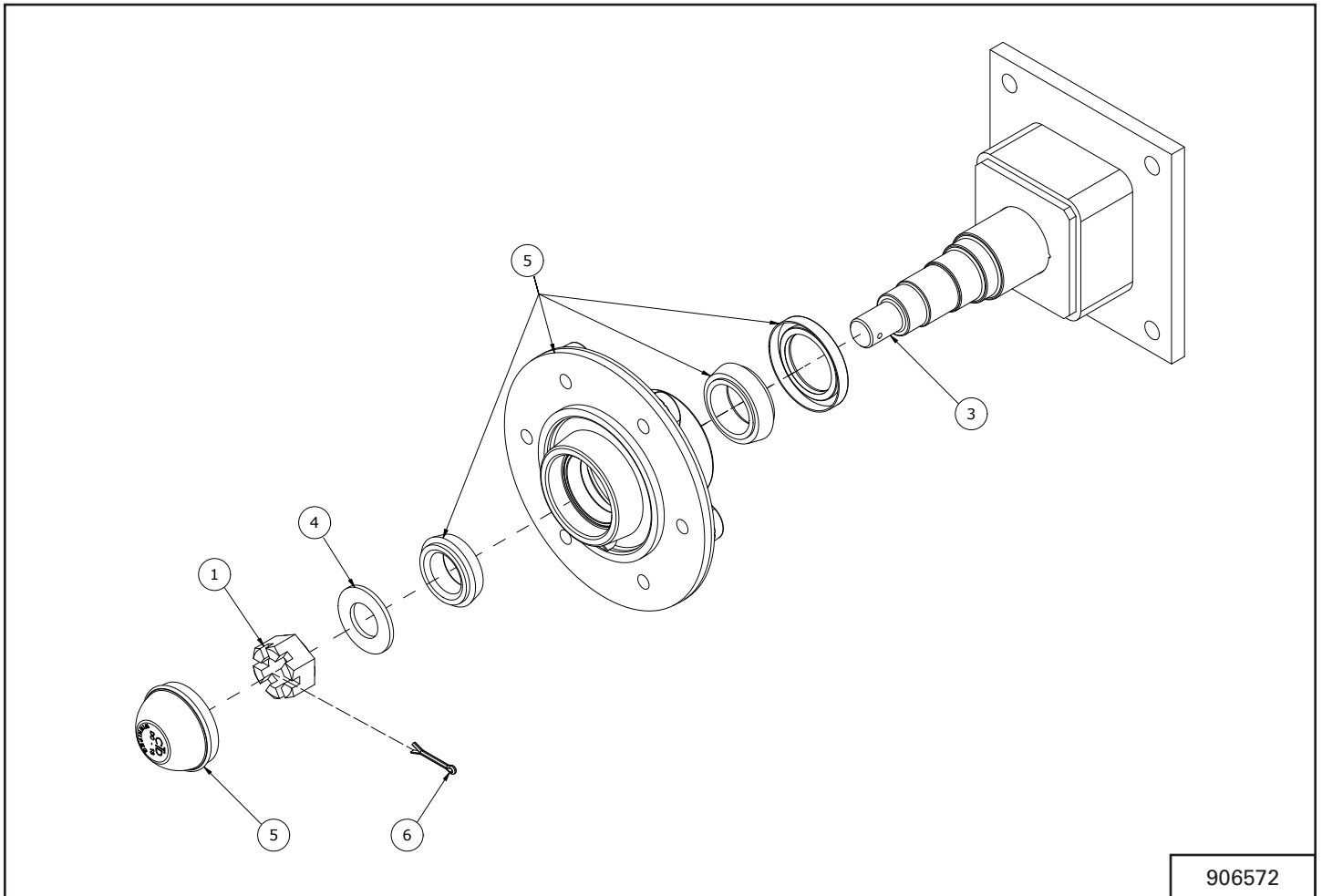

ITEM	PART NUMBER	DESCRIPTION	QTY.
1	810010	NUT-SLOTTED 7/8 UNF (BR)	1
2	904902	GREASE GRADE 2	28g
3	906466	STUB AXLE WELDMENT	1
4	967713	7/8" SAE FLAT WASHER (BR)	1
5	967731	HUB CTD H611 COMPLETE ASSY	1
6	9812486	1/8" X 1-1/2" COTTER PIN (BR)	1

STUB AXLE - 85, 95 MODELS

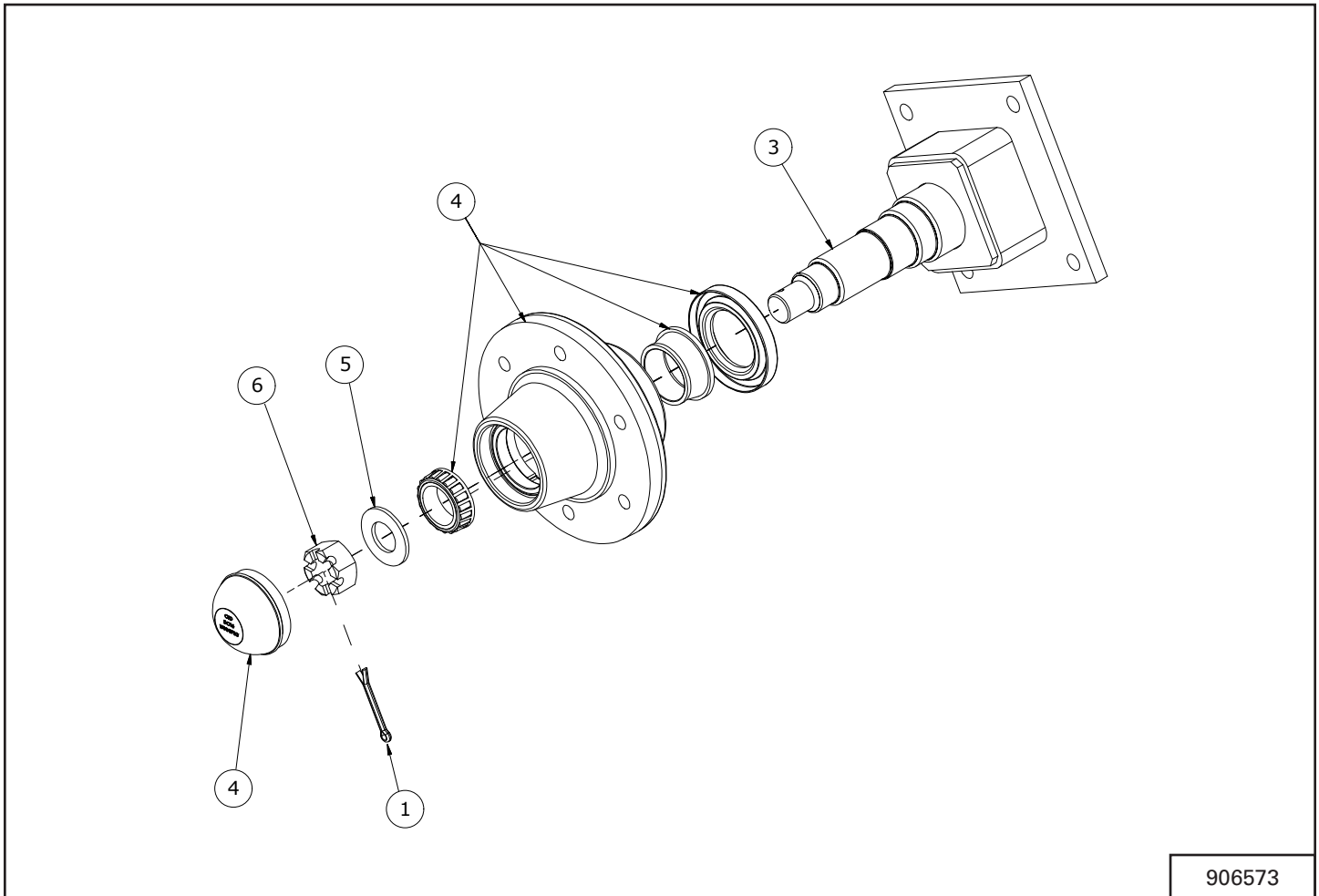

906573

ITEM	PART NUMBER	DESCRIPTION	QTY.
1	81207	3/16" X 2" COTTER PIN (BR)	1
2	904902	GREASE GRADE 2	32g
3	906467	STUB AXLE WELDMENT	1
4	960586	HUB CTD H618 COMPLETE ASSY	1
5	967218	1" SAE FLAT WASHER (BR)	1
6	967498	SLOTTED HEX NUT 1-14 GRADE 5 ZP	1

STUB AXLE - 114 MODELS

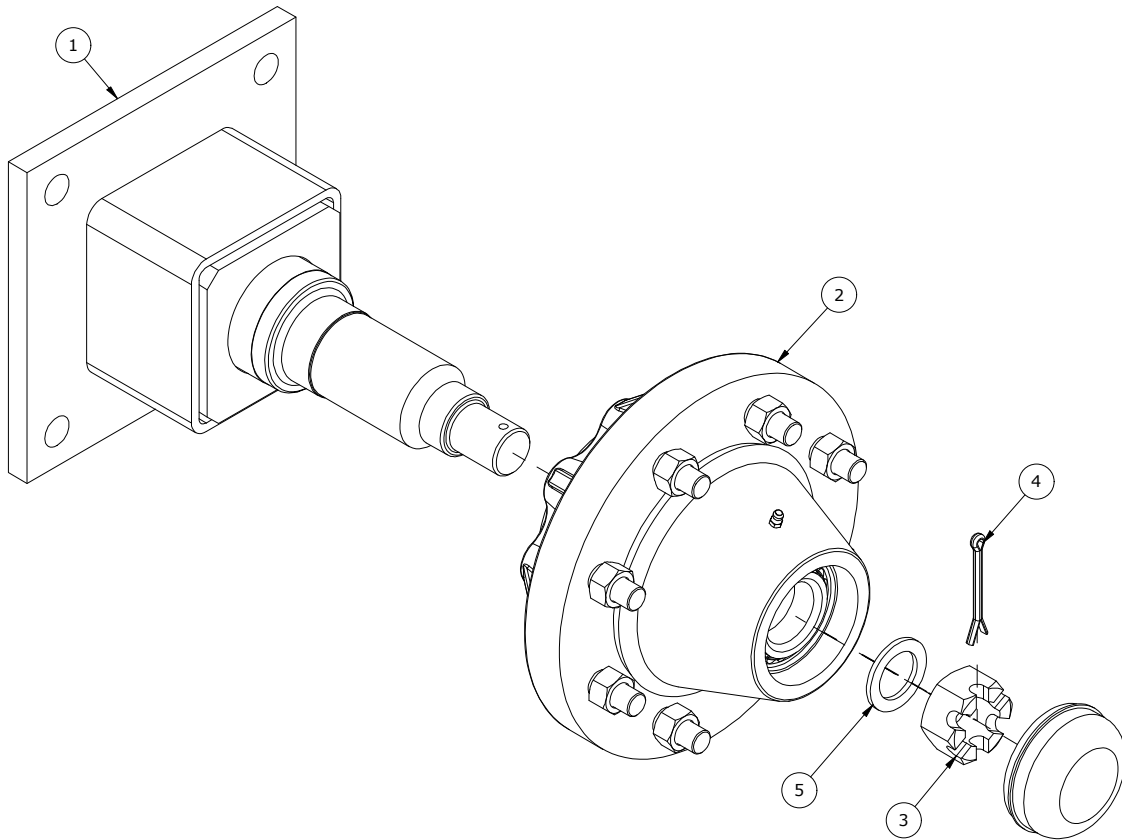

909191

ITEM	PART NUMBER	DESCRIPTION	QTY.
1	906109	BOLT ON STUB AXLE WELDT	1
2	909190	HUB-8 BOLT BS16104	1
3	960037	SLOTTED HEX NUT 1 1/4" UNF	1
4	967252	3/16" x 2-1/2" COTTER PIN	1
5	9812442	1 1/4" X 10GA FLAT WASHER (BR)	1

LIFT ARMS - 70 MODELS

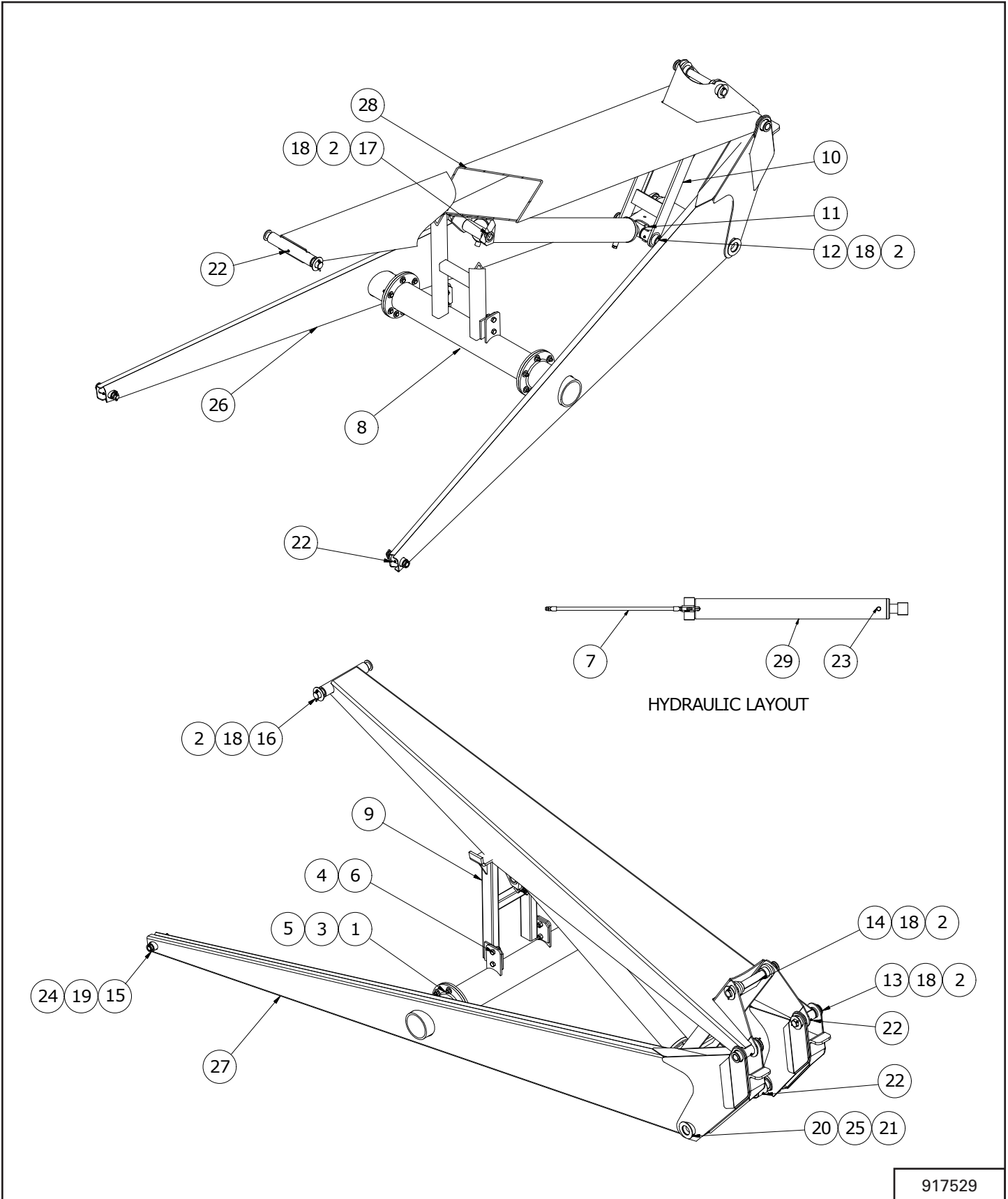

ITEM	PART NUMBER	DESCRIPTION	QTY.
1	811791	1/2" X 2" HEX BOLT (PL)	16
2	81210	1/4" X 2" COTTER PIN (PL)	6
3	812364	1/2" LOCK NUT (PL)	16
4	812482	5/8" LOCK NUT (PL)	4
5	81638	1/2" BS FLAT WASHER (PL)	32
6	84270	5/8" X 1 3/4" HEX BOLT (PL)	4
7	912751	HYDRAULIC ROUTING	1
8	914966	LIFT ARM TORQUE TUBE WELDT	1
9	925757	WELDT - CRADLE BS1370	1
10	960624	YOKE WELDMENT	1
11	960625	LINK WELDMENT	1
12	960628	BOTTOM CYL PIN WELDT 1.500" DIA	1
13	960629	LIFT ARM CLEV PIN WELDT 1.500" DIA	2
14	960630	TOP YOKE PIN WELDT 1.500" DIA	1
15	960631	LIFT ARM CLEVIS PIN WELDT 1.000" DIA	2
16	960632	LIFT ARM PIVOT PIN WELDT 1.500" DIA	1
17	960691	TOP CYLINDER PIN WELDT 1.500" DIA	1
18	967135	1 1/2" RIM WASHER (10GA) (PL)	6
19	967140	1" X 10GA NARROW RIM WASH (PL)	2
20	967153	2" X 10GA NARROW RIM WASHER (PL)	1
21	967162	5/16" X 3" COTTER PIN (PL)	1
22	967164	DRIVE-IN GREASE ZERK	9
23	967908	PLUG-8 ORB VENT	1
24	9812434	1/4" X 1 1/2" COTTER PIN (PL)	2
25	F0034	CONNECTING PIN WELDT 2.000" DIA	1
26	F1771	LOWER LIFT ARM (LH)	1
27	F1772	LOWER LIFT ARM (RH)	1
28	F9707	UPPER LIFT ARM (70')	1
29	F9778	4.5" X 42.5" HYDRAULIC CYLINDER	1

LIFT ARMS - 85, 95 MODELS

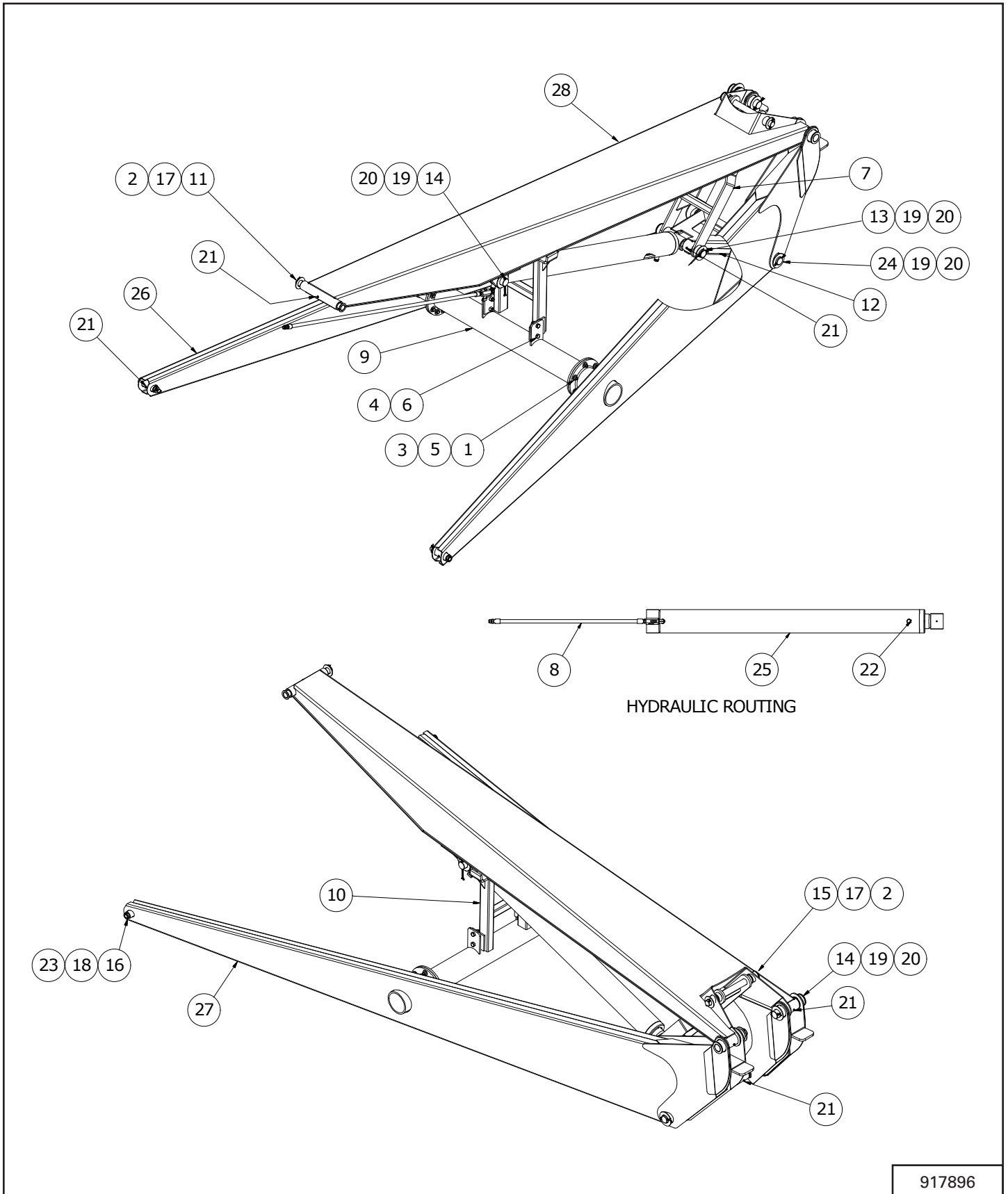

917896

ITEM	PART NUMBER	DESCRIPTION	QTY.
1	811791	1/2" X 2" HEX BOLT (PL)	16
2	81210	1/4" X 2" COTTER PIN (PL)	2
3	812364	1/2" LOCK NUT (PL)	16
4	812482	5/8" LOCK NUT (PL)	4
5	81638	1/2" BS FLAT WASHER (PL)	32
6	84270	5/8" X 1 3/4" HEX BOLT (PL)	4
7	907342	WELDT-YOKE BS13"	1
8	912751	HYDRAULIC ROUTING	1
9	914956	LIFT ARM TORQUE TUBE WELDMENT	1
10	924565	WELDT - CRADLE BS1385	1
11	960632	LIFT ARM PIVOT PIN WELDT 1.500" DIA	1
12	960688	13" LINK WELDMENT	1
13	960690	BOTTOM CYL PIN WELDT 2.000" DIA	1
14	960692	TOP CYLINDER PIN WELDT 2.000" DIA	3
15	960694	WELDMENT-TOPYOKE PIN 1.500" DIA	1
16	960695	LIFT ARM CLEVIS PIN 1.000" DIA	2
17	967135	1 1/2" RIM WASHER (10GA) (PL)	2
18	967140	1" X 10GA NARROW RIM WASH (PL)	2
19	967153	2" X 10GA NARROW RIM WASHER (PL)	5
20	967162	5/16" X 3" COTTER PIN (PL)	5
21	967164	DRIVE-IN GREASE ZERK	9
22	967908	PLUG-8 ORB VENT	1
23	9812434	1/4" X 1 1/2" COTTER PIN (PL)	2
24	F0035	CONNECTING LINK PIN WELDT 2.000" DIA	1
25	F0445M	CYLINDER-5.0X51.35	1
26	F1769	LOWER LIFT ARM - LEFT HAND	1
27	F1770	LOWER LIFT ARM - RIGHT HAND	1
28	F1943	WELDT-UPPER LIFT ARM	1

LIFT ARMS - 114 MODELS

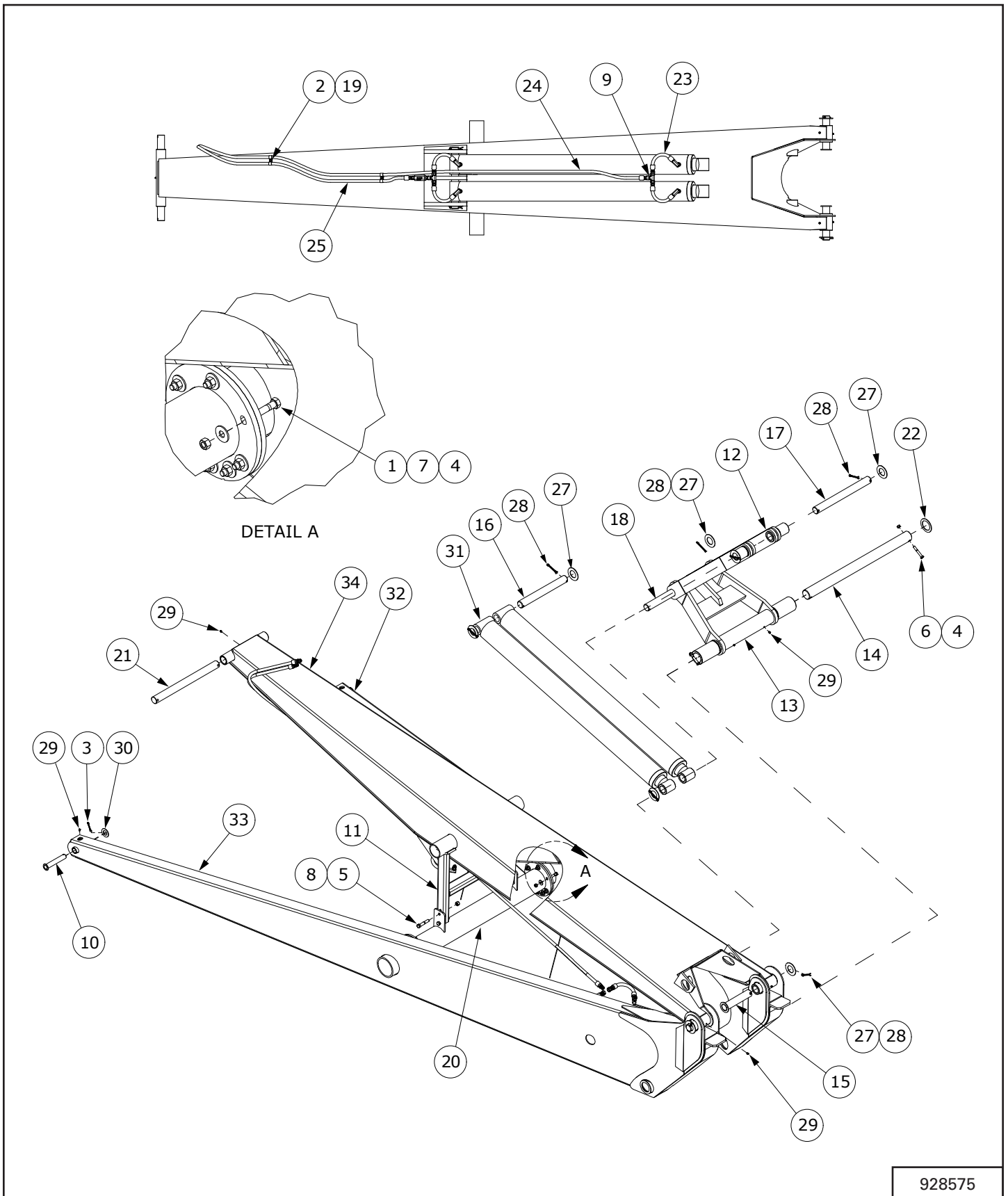

928575

ITEM	PART NUMBER	DESCRIPTION	QTY.
1	811791	1/2" X 2" HEX BOLT (PL)	16
2	812026	5/16" X 1" HEX BOLT (PL)	2
3	81210	1/4" X 2" COTTER PIN (PL)	2
4	812364	1/2" LOCK NUT (PL)	18
5	812482	5/8" LOCK NUT (PL)	4
6	81629	1/2" X 3 1/2" HEX BOLT (PL)	2
7	81638	1/2" BS FLAT WASHER (PL)	32
8	81669	5/8" X 3 1/2" HEX BOLT (PL)	4
9	865341	TEE-10MJIC X -10MJIC X -10 FJIC	1
10	905779	AXLE PIN WELDT 1.250" DIA	2
11	905786	CRADLE REST WELDMENT	1
12	908464	YOKE ARM WELDMENT	2
13	908472	16" LINK WELDMENT	1
14	908474	PIN-CONNECTING YOKE 2.750" DIA	1
15	908476	LIFT ARM PIN WELDT 2.000" DIA	2
16	908478	CYL PIN ROD 2.000" DIA	1
17	908480	UPPER LIFT ARM PIN 2.000" DIA	1
18	908490	LIFT PIN ROD 2.000" DIA	1
19	913193	P-CLIP 0.75	4
20	914760	LIFT ARM TORQUE TUBE WELDT (1305MM LG)	1
21	928645	UPPER LIFT ARM PIN	1
22	930470L	2 3/4" X 10GA NARROW RIM WASHER	2
23	930540	HOSE-8 X -8MORB 90 X -10JIC	4
24	930976	HOSE-8 X -10MJIC X -10MJIC	1
25	930977	ASSY-HYDRAULIC ROUTING	1
26	967103	TIE 30"	2
27	967153	2" X 10GA NARROW RIM WASHER (PL)	8
28	967162	5/16" X 3" COTTER PIN (PL)	8
29	967164	DRIVE-IN GREASE ZERK	7
30	9812487	1 1/4" X 10GA NARROW RIM WASHER (PL)	2
31	F0664M	CYLINDER 5.00 X 55.35 3/4 ORB	2
32	F1767	LOWER LIFT ARM WELDT - LEFT	1
33	F1768	LOWER LIFT ARM WELDT - RIGHT	1
34	F2315	UPPER LIFT ARM WELDMENT	1

TUBES - 70 MODELS

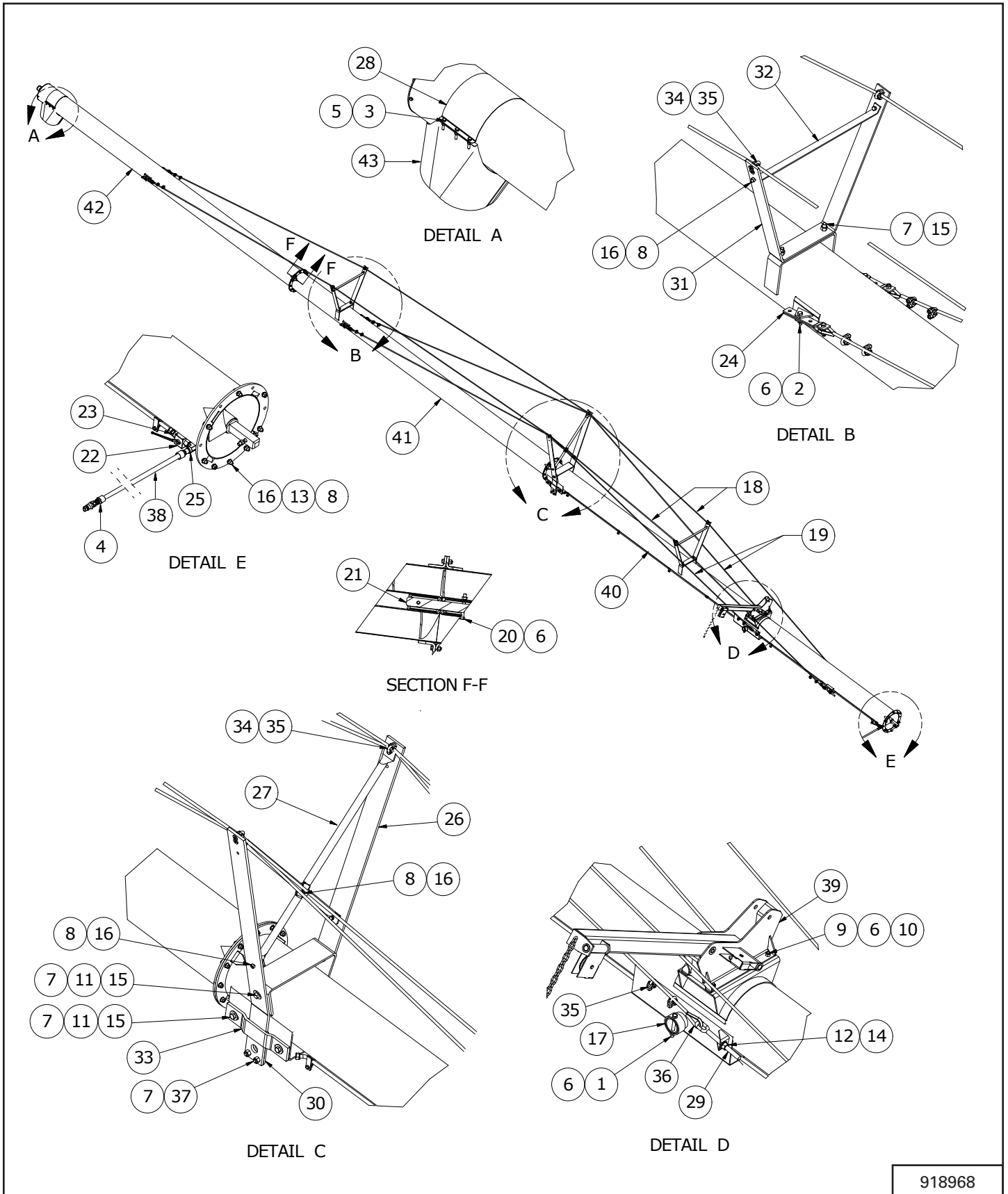

918968

ITEM	PART NUMBER	DESCRIPTION	QTY.
1	811691	1/2" X 4 1/2" HEX BOLT (PL)	2
2	811791	1/2" X 2" HEX BOLT (PL)	8
3	811795	3/8" X 2" HEX BOLT (PL)	6
4	812208	NIPPLE 1/2" BODY 1/2"-14 NPTF QUICK CONNECT	1
5	812363	3/8" LOCK NUT (PL)	6
6	812364	1/2" LOCK NUT (PL)	20
7	812482	5/8" LOCK NUT (PL)	14
8	81599	7/16" X 1 1/2" HEX BOLT (PL)	41
9	81620	1/2" X 1 1/4" HEX BOLT PL	4
10	81638	WASHER 0.563 FLAT STD HS PL	4
11	81678	5/8" FLAT WASHER STD (PL)	8
12	81700	3/4" HEX NUT (PL)	4
13	84041	7/16" SAE FLAT WASHER (PL)	64
14	84050	3/4" S.A.E. FLAT WASHER (PL)	4
15	84299	5/8" X 2" HEX BOLT GR.5 (PL)	10
16	86273	7/16" LOCK NUT (PL)	41
17	905736	UNDERCARR PIN SLEEVE 3 1/6"ID X 3 1/2"OD X 1 1/2"	2
18	907442	UPPER CABLE BUNDLE	1
19	907443	LOWER CABLE BUNDLE	1
20	910025	1/2" X 4" GR8 HEX BOLT (PL)	6
21	918739	SHAFT-FLTG SQUARE	3
22	960057	-08 FNPT 2 WAY BALL VALVE	1
23	960152	ADAPTOR STRAIGHT -10 MJIC X -8 MNPT	1
24	960244	CABLE YOKE	8
25	960585	1/2" X 90 DEGREE STREET ELBOW (STEEL)	1
26	960607	MAIN BRIDGING YOKE 1/2" X 4" X 59 5/8"	2
27	960608	MAIN BRIDGING X-BRACE	2
28	960612	3-BOLT SPOUT CLAMP	1
29	960613	CABLE TIGHTENER CHAIN LINK (03/4" X 7 7/8")	4
30	960615	MAIN BRIDGING YOKE MOUNT 3/8" X 4" X 21"	1
31	960675	LOWER BRIDGING YOKE	2
32	960677	BRIDGING TIE PL	2
33	960745	MAIN BDG YOKE CLP WELD'T	2
34	964001	1" X 7/16" X 10GA FLAT WASHER (PL)	12
35	964565	1/2" CABLE CLAMP (PL)	14
36	964587	1/2" CABLE THIMBLE	4
37	967284	BOLT FLAT HEAD SOCKET 5/8 X 1 3/4" (PL)	4
38	967463	HOSE-8 X -8MNPT X -8MNPT	1
39	F1913	ASSY-BS13 LIFT BOOM	1
40	F1917	ASSY-BS1370 BOTTOMTUBE (AP)	1
41	F1918	ASSY-BS1370 CENTERTUBE	1
42	F1919	ASSY-BS1370 TOP TUBE	1
43	F9716	DISCHARGE SPOUT 13" B/S	1

TUBES - 85 MODELS

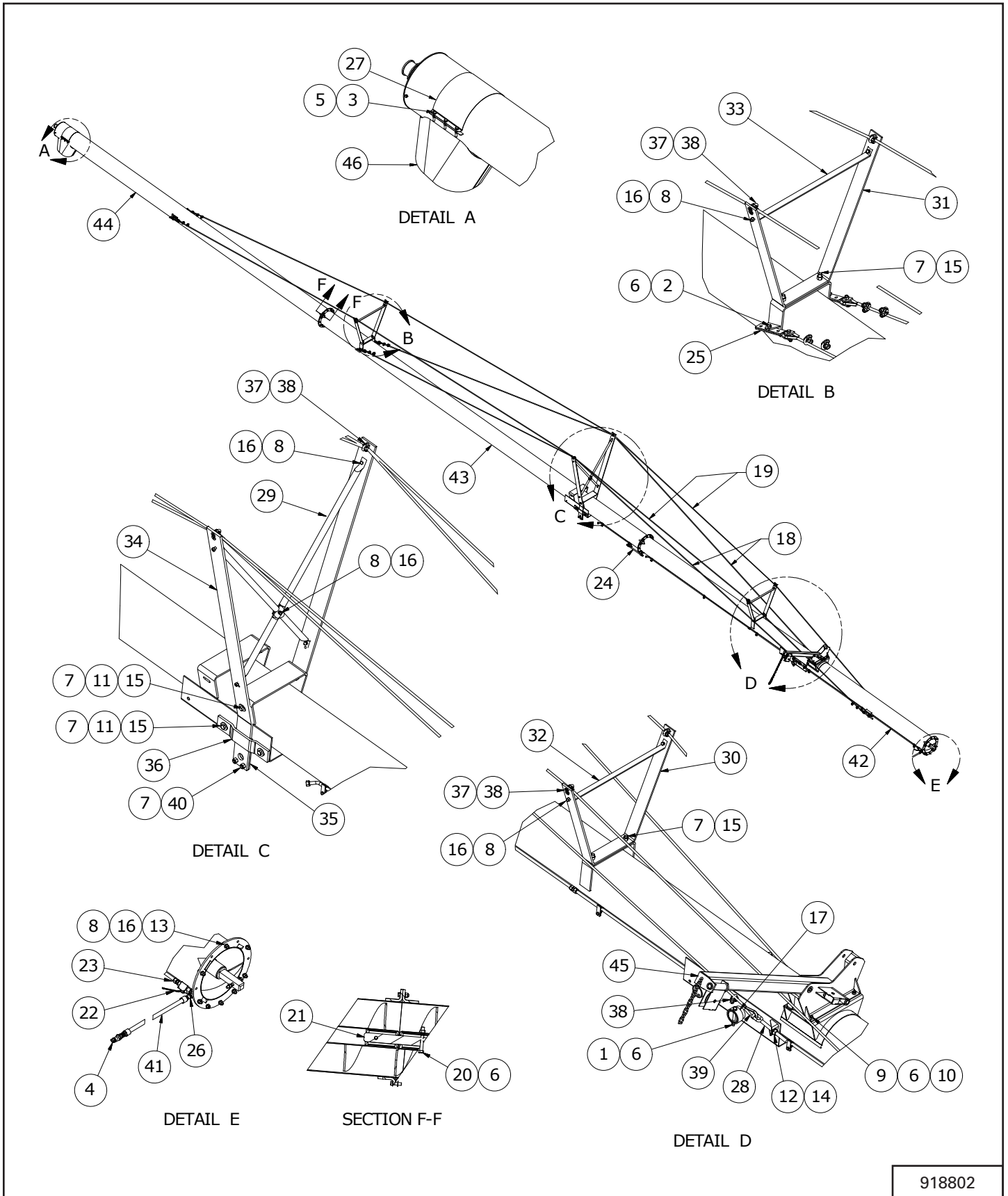

918802

ITEM	PART NUMBER	DESCRIPTION	QTY.
1	811691	1/2" X 4 1/2" HEX BOLT (PL)	2
2	811791	1/2" X 2" HEX BOLT (PL)	8
3	811795	3/8" X 2" HEX BOLT (PL)	6
4	812208	NIPPLE 1/2" BODY 1/2"-14 NPTF QUICK CONNECT	1
5	812363	3/8" LOCK NUT (PL)	6
6	812364	NUT-HEX-GR5-(ZT)-1/2_13	20
7	812482	5/8" LOCK NUT GR5 (PL)	14
8	81599	7/16" X 1 1/2" HEX BOLT (PL)	41
9	81620	1/2" X 1 1/4" HEX BOLT PL	4
10	81638	WASHER 0.563 FLAT STD HS PL	4
11	81678	5/8" FLAT WASHER STD (PL)	8
12	81700	3/4" HEX NUT (PL)	4
13	84041	7/16" SAE FLAT WASHER (PL)	64
14	84050	3/4" S.A.E. FLAT WASHER (PL)	4
15	84299	5/8" X 2" HEX BOLT GR.5 (PL)	10
16	86273	7/16" LOCK NUT (PL)	41
17	905736	UNDERCARR PIN SLEEVE 3 1/6"ID X 3 1/2"OD X 1 1/2"	2
18	907444	LOWER CABLE BUNDLE	1
19	907445	UPPER CABLE BUNDLE	1
20	910025	1/2" X 4" GR8 HEX BOLT (PL)	6
21	918739	SHAFT-FLTG SQUARE	3
22	960057	-08 FNPT 2 WAY BALL VALVE	1
23	960152	ADAPTOR STRAIGHT -10 MJIC X -8 MNPT	1
24	960162	HOSE-8 X -10MJIC X -10MJIC	1
25	960244	CABLE YOKE	8
26	960585	1/2" X 90 DEGREE STREET ELBOW (STEEL)	1
27	960612	3-BOLT SPOUT CLAMP	1
28	960613	CABLE TIGHTENER CHAIN LINK (Ø3/4" X 7 7/8")	4
29	960674	BRACE BDG MAIN 1 5/16" OD X 56" LG	2
30	960675	LOWER BRIDGING YOKE	1
31	960676	UPPER BRIDGING YOKE	1
32	960677	BRIDGING TIE PL	1
33	960678	BRIDGING TIE PL	1
34	960742	MAIN BRIDGING YOKE 1/2 X 4 X 74"	2
35	960743	MAIN BRIDGING YOKE MOUNT	1
36	960745	MAIN BDG YOKE CLP WELD'T	2
37	964001	1" X 7/16" X 10GA FLAT WASHER (PL)	12
38	964565	1/2" CABLE CLAMP (PL)	14
39	964587	1/2" CABLE THIMBLE	4
40	967284	BOLT FLAT HEAD SOCKET 5/8 X 1 3/4" (PL)	4
41	967463	HOSE-8 X -8MNPT X -8MNPT	1
42	F1906	ASSY-BS1385 BOTTOM TUBE (AP)	1
43	F1907	ASSY-BS1385 CENTER TUBE (AP)	1

ITEM	PART NUMBER	DESCRIPTION	QTY.
44	F1908	ASSY-BS1385TOP TUBE	1
45	F1913	ASSY-BS13 LIFT BOOM	1
46	F9716	DISCHARGE SPOUT 13" B/S	1

Farm King



TUBES - 95 MODELS

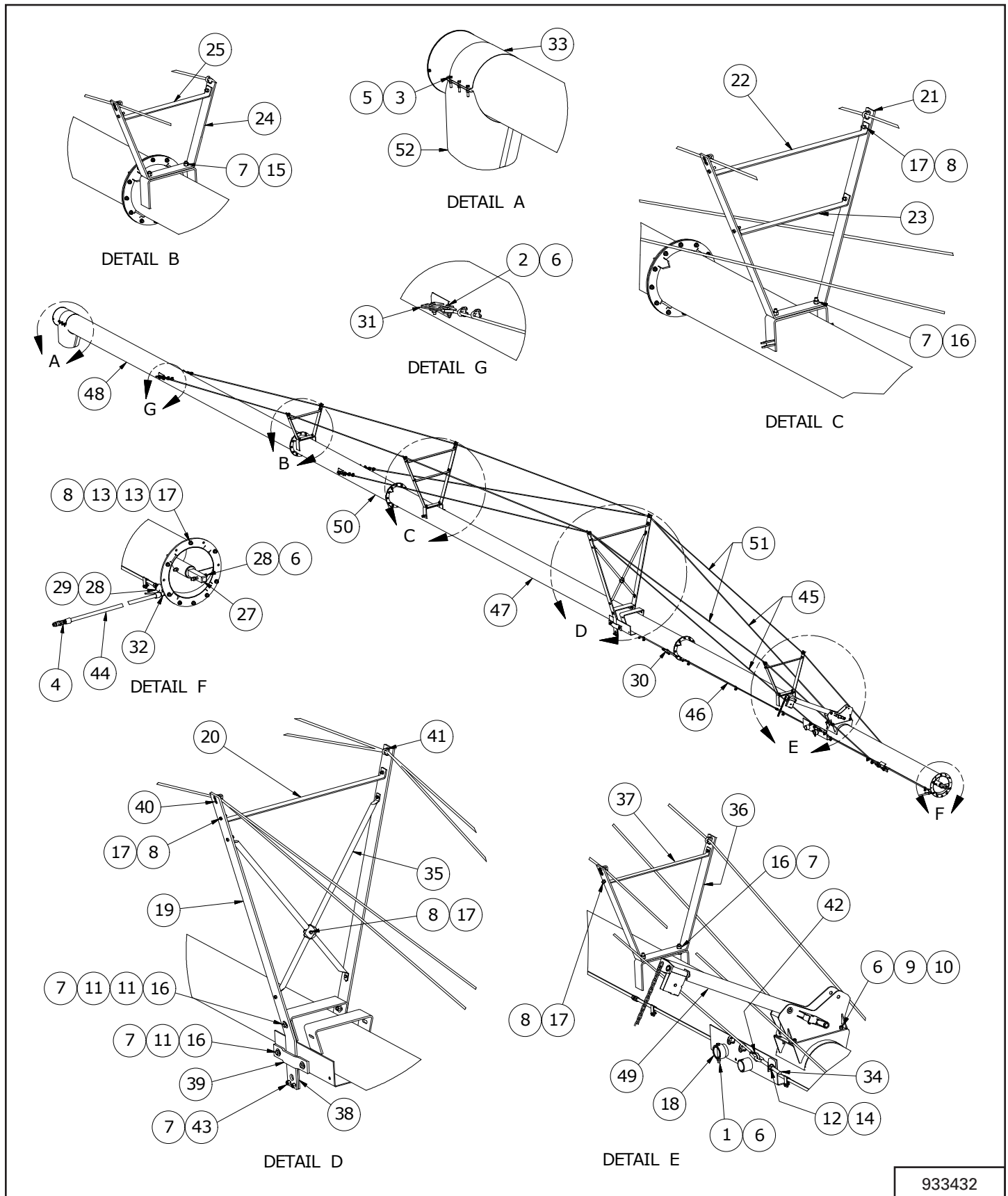

933432

ITEM	PART NUMBER	DESCRIPTION	QTY.
1	811691	1/2" X 4 1/2" HEX BOLT (PL)	2
2	811791	1/2" X 2" HEX BOLT (PL)	8
3	811795	3/8" X 2" HEX BOLT (PL)	6
4	812208	NIPPLE 1/2" BODY 1/2"-14 NPTF QUICK CONNECT	1
5	812363	3/8" LOCK NUT (PL)	6
6	812364	NUT-HEX-GR5-(ZT)-1/2_13	22
7	812482	5/8" LOCK NUT GR5 (PL)	16
8	81599	7/16" X 1 1/2" HEX BOLT (PL)	59
9	81620	1/2" X 1 1/4" HEX BOLT PL	4
10	81638	WASHER 0.563 FLAT STD HS PL	4
11	81678	5/8" FLAT WASHER STD (PL)	8
12	81700	3/4" HEX NUT (PL)	4
13	84041	7/16" SAE FLAT WASHER (PL)	88
14	84050	3/4" S.A.E. FLAT WASHER (PL)	4
15	84270	5/8" X 1 3/4" HEX BOLT (PL)	2
16	84299	5/8" X 2" HEX BOLT GR.5 (PL)	10
17	86273	7/16" LOCK NUT (PL)	59
18	905736	UNDERCARR PIN SLEEVE 3 1/6"ID X 3 1/2"OD X 1 1/2"	2
19	909942	MAIN BRIDGING YOKE PLATE	2
20	909943	MAIN BRIDGING TIE PLATE	1
21	909944	UPPER BRIDGING YOKE 3/8"	1
22	909945	UPPER BRIDGING TOPTIE PL	1
23	909946	UPPER BRIDGING BOTTOMTIE PLATE	1
24	909947	EXTENSIONTUBE BRIDGING YOKE	1
25	909948	EXTENSIONTUBE BRIDGINGTIE PLATE	1
26	910025	1/2" X 4" GR8 HEX BOLT (PL)	8
27	918739	SHAFT-FLTG SQUARE	4
28	960057	-08 FNPT 2 WAY BALL VALVE	1
29	960152	ADAPTOR STRAIGHT -10 MJIC X -8 MNPT	1
30	960162	HOSE-8 X -10MJIC X -10MJIC	1
31	960244	CABLE YOKE	8
32	960585	1/2" X 90 DEGREE STREET ELBOW (STEEL)	1
33	960612	3-BOLT SPOUT CLAMP	1
34	960613	CABLE TIGHTENER CHAIN LINK (Ø3/4" X 7 7/8")	4
35	960674	BRACE BDG MAIN 1 5/16" OD X 56" LG	2
36	960675	LOWER BRIDGING YOKE	1
37	960677	BRIDGING TIE PL	1
38	960743	MAIN BRIDGING YOKE MOUNT	1
39	960745	MAIN BDG YOKE CLP WELD'T	2
40	964001	1" X 7/16" X 10GA FLAT WASHER (PL)	16
41	964565	1/2" CABLE CLAMP (PL)	16
42	964587	1/2" CABLE THIMBLE	4
43	967284	BOLT FLAT HEAD SOCKET 5/8 X 1 3/4" (PL)	4

ITEM	PART NUMBER	DESCRIPTION	QTY.
44	967463	HOSE-8 X -8MNPT X -8MNPT	1
45	F0915	LOWER CABLE BUNDLE	1
46	F1906	ASSY-BS1385 BOTTOMTUBE (AP)	1
47	F1907	ASSY-BS1385 CENTERTUBE (AP)	1
48	F1908	ASSY-BS1385 TOP TUBE	1
49	F1913	ASSY-BS13 LIFT BOOM	1
50	F1914	ASSY-BS13 10' EXTENSION	1
51	F9172	UPPER CABLE BUNDLE	1
52	F9716	DISCHARGE SPOUT 13" B/S	1

Farm King



TUBES - 114 MODELS

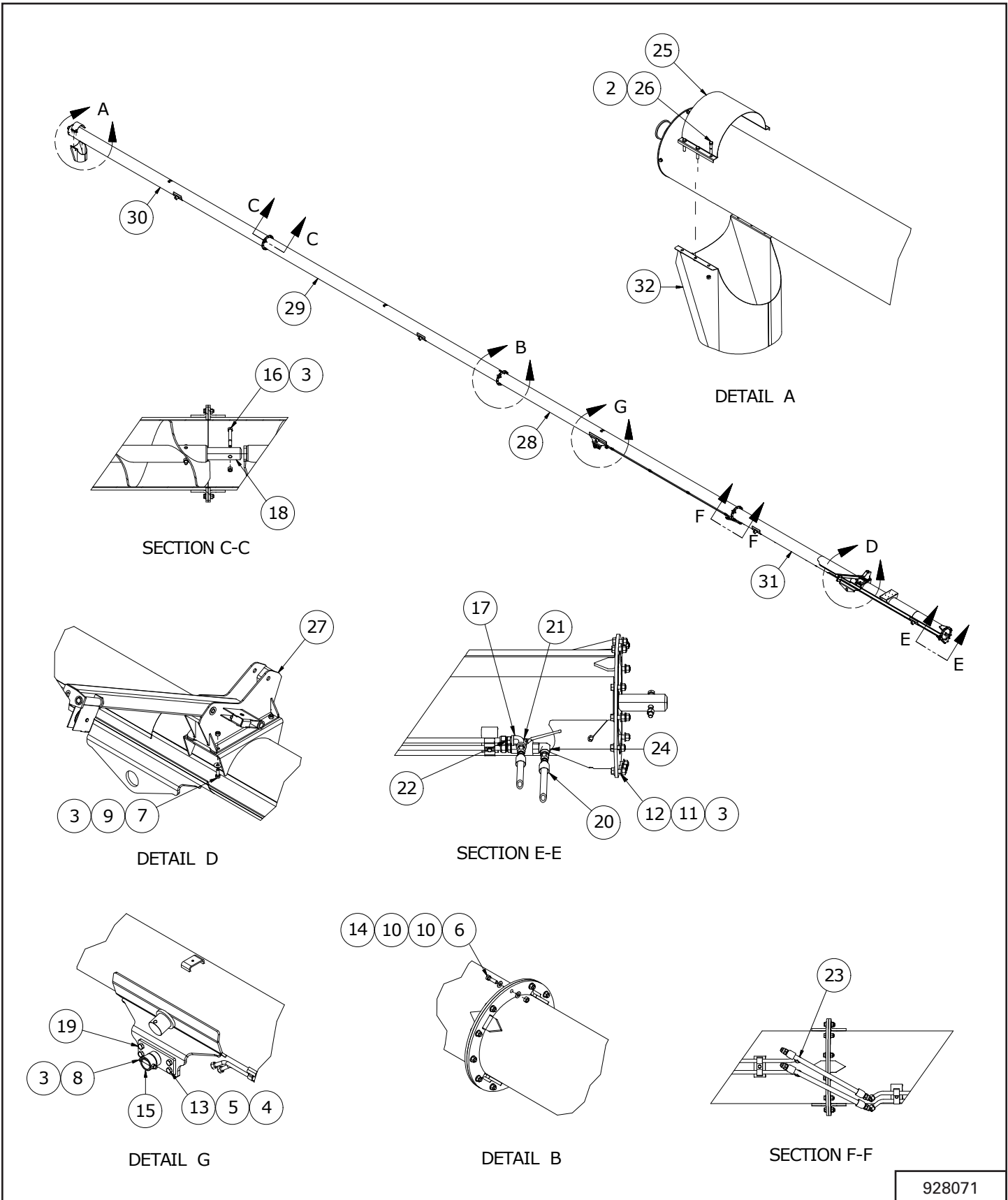

928071

ITEM	PART NUMBER	DESCRIPTION	QTY.
1	812208	NIPPLE 1/2" BODY 1/2"-14 NPTF QUICK CONNECT	2
2	812363	3/8" LOCK NUT (PL)	6
3	812364	1/2" LOCK NUT (PL)	26
4	812482	5/8" LOCK NUT (PL)	8
5	812639	WASHER 0.625 SAE FLAT BS PL	8
6	81599	7/16" X 1 1/2" HEX BOLT (PL)	36
7	81620	1/2" X 1 1/4" HEX BOLT PL	4
8	81629	1/2" X 3 1/2" HEX BOLT (PL)	2
9	81638	WASHER 0.563 FLAT STD HS PL	4
10	84041	7/16" SAE FLAT WASHER (PL)	72
11	84048	1/2" SAE FLAT WASHER (PL)	24
12	84277	1/2" X 1 1/2" HEX BOLT (PL)	12
13	84299	5/8" X 2" HEX BOLT GR.5 (PL)	8
14	86273	7/16" LOCK NUT (PL)	36
15	905807	UPPER LIFT ARM PIN COLLAR	2
16	910025	1/2" X 4" GR8 HEX BOLT (PL)	8
17	914930	ELBOW-8FPT X -8 FPT	1
18	918739	SHAFT-FLTG SQUARE	4
19	928648	WELDT-LIFT ARM PIVOT MOUNT	2
20	933109	HOSE-08 X -08MNPT X -08MNPT	2
21	960057	-08 FNPT 2 WAY BALL VALVE	1
22	960152	ADAPTOR STRAIGHT -10 MJIC X -8 MNPT	2
23	960162	HOSE-8 X -10MJIC X -10MJIC	2
24	960585	1/2" X 90 DEGREE STREET ELBOW (STEEL)	1
25	960612	3-BOLT SPOUT CLAMP	1
26	967291	3/8" X 2" FULL THREAD HEX BOLT (PL)	6
27	F1913	ASSY-BS13 LIFT BOOM	1
28	F2163	ASSY-BS13114 SECONDTUBE	1
29	F2164	ASSY-BS13114THIRDTUBE	1
30	F2165	ASSY-BS13114 FOURHTUBE	1
31	F2656	ASSY-BS13114 FIRSTTUBE	1
32	F9716	DISCHARGE SPOUT 13" B/S	1

TUBE COMPONENTS - 70 MODELS

First Tube (Intake)

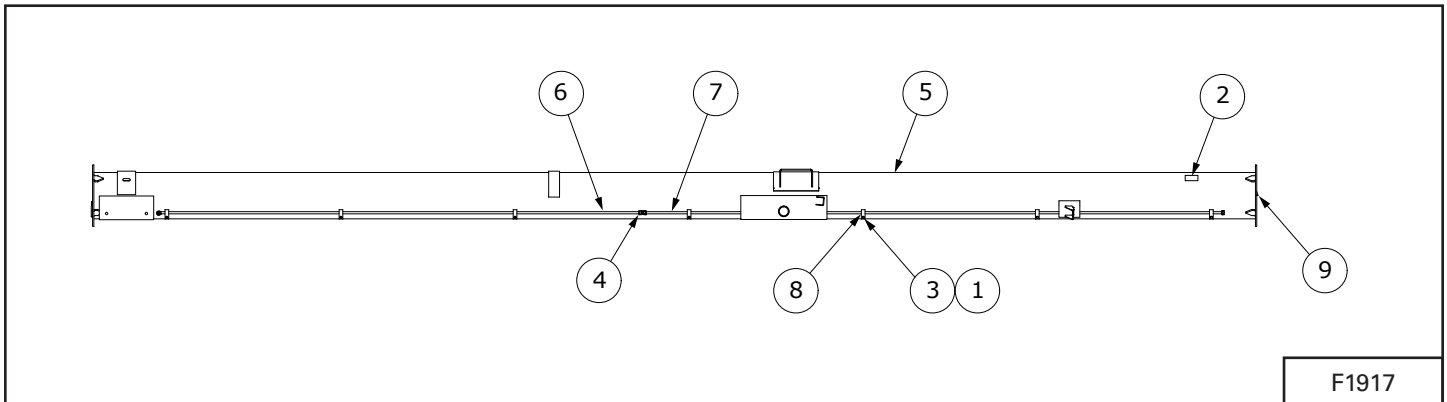

ITEM	PART NUMBER	DESCRIPTION	QTY.
1	86170	3/8" X 1" HEX BOLT GR.5 (PL)	7
2	105420	REFERENCE PLATE, BUHLER S/N	1
3	812363	3/8" LOCK NUT (PL)	7
4	812711	JIC UNION -10-10	1
5	918974	WELDT-BS1370 BOTTOMTUBE	1
6	960144	5/8" X 11' HYD LINE (JIC FEMALE ENDS)	1
7	960468	5/8" X 13'-4" HYD LINE (JIC FEMALE ENDS)	1
8	960639L	HYDRAULIC LINE CLAMP	7
9	928650	WELDT-BS13114 BOTTOM FLTG	1

Second Tube

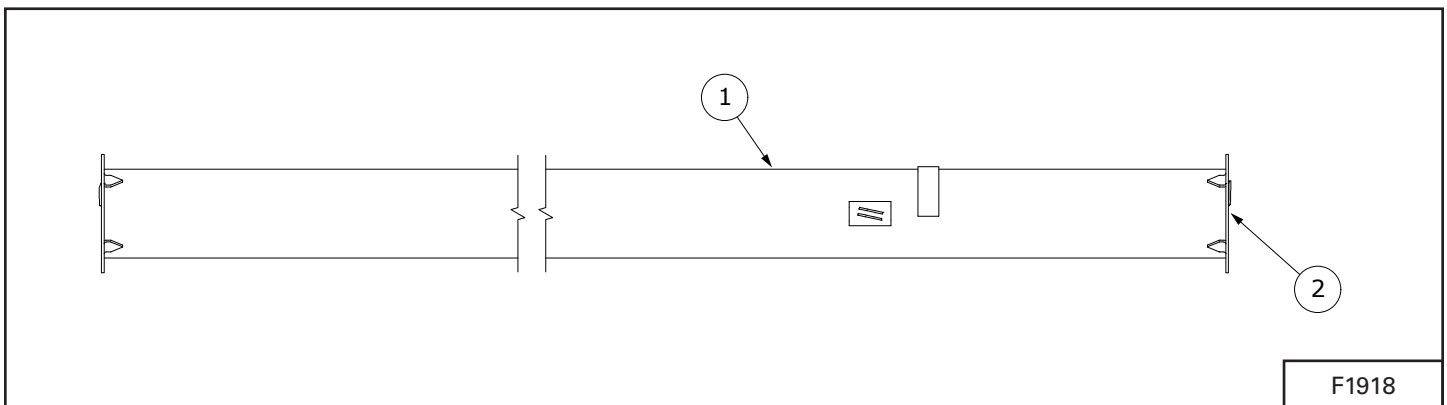

ITEM	PART NUMBER	DESCRIPTION	QTY.
1	918973	WELDT-BS1370 CENTERTUBE	1
2	929844	WELDT-BS1370 CENTER FLTG	1

Third Tube

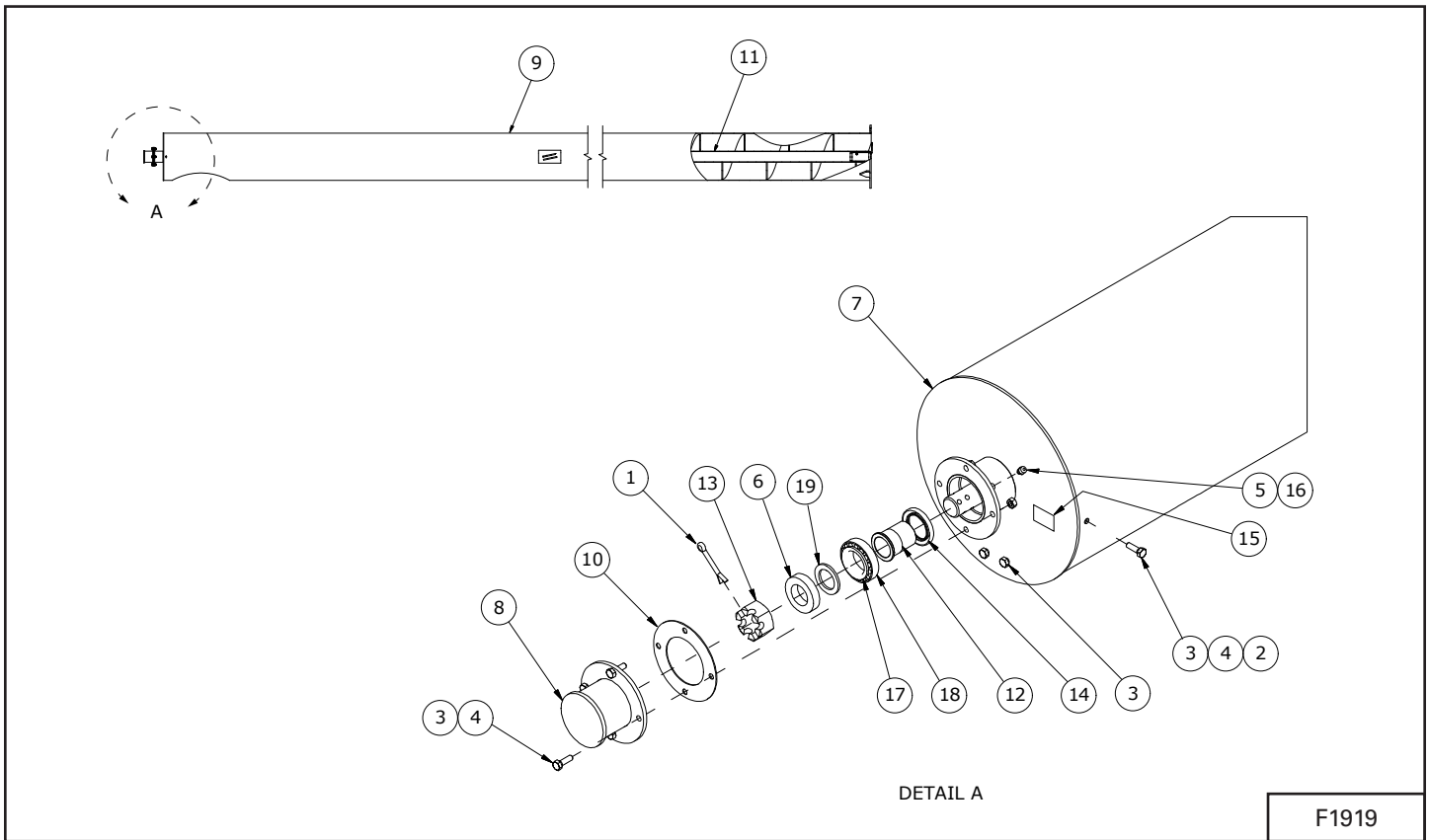

F1919

ITEM	PART NUMBER	DESCRIPTION	QTY.
1	81210	1/4" X 2" COTTER PIN (PL)	1
2	81546	5/16" FLAT WASHER (PL)	2
3	812026	5/16" X 1" HEX BOLT (PL)	8
4	812362	5/16" LOCK NUT (PL)	6
5	904902	GREASE GRADE 2	1
6	918816L	PLATE-TOP FLTG ADJ.	1
7	918817	WELDT-TOP PLATE	1
8	918828	WELDT-TOP FLANGE CAP	1
9	918969	WELDT-BS1370TOPTUBE	1
10	920211	GASKET-FLTGTENSIONER	1
11	929845	WELDT-BS1370TOP FLTG	1
12	960035	END BEARING SLEEVE	1
13	960037	SLOTTED HEX NUT 1 1/4" UNF	1
14	960125	OIL SEAL (CR14939)	1
15	966699	DECAL-GREASE	1
16	967164	DRIVE-IN GREASE ZERK	1
17	967708	BEARING CONE (LM29749)	1
18	967709	BEARING CUP (LM29710)	1
19	9812442	1 1/4" X 10GA FLAT WASHER (BR)	1

TUBE COMPONENTS - 85 MODELS

First Tube (Intake)

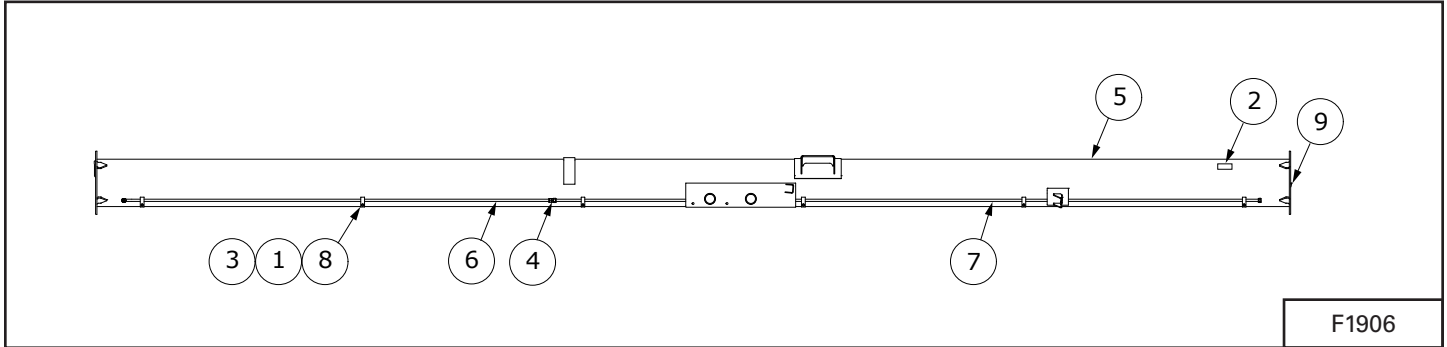

ITEM	PART NUMBER	DESCRIPTION	QTY.
1	86170	3/8" X 1" HEX BOLT GR.5 (PL)	6
2	105420	REFERENCE PLATE, BUHLER S/N	1
3	812363	3/8" LOCK NUT (PL)	6
4	812711	JIC UNION -10-10	1
5	918808	WELDT-BS1385 BOTTOMTUBE	1
6	960200	HYD LINE 5/8" OD X 9'-7"	1
7	960467	HYD LINE 5/8" X 15'-10"	1
8	960639L	HYDRAULIC LINE CLAMP	6
9	928650	WELDT-BS13114 BOTTOM FLTG	1

Second Tube

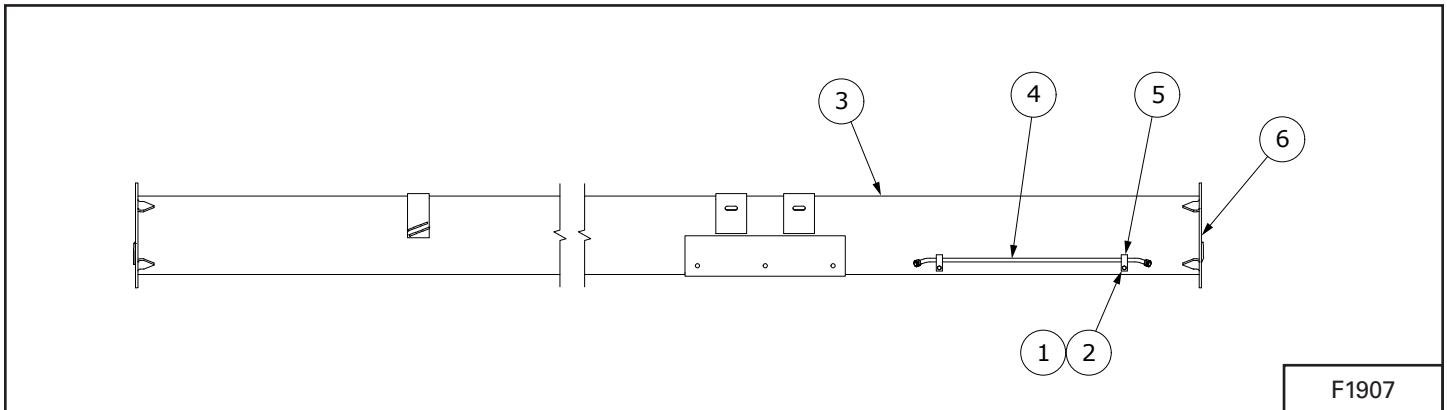

ITEM	PART NUMBER	DESCRIPTION	QTY.
1	812363	3/8" LOCK NUT (PL)	2
2	86170	3/8" X 1" HEX BOLT GR.5 (PL)	2
3	918812	WELDT-BS1385 CENTERTUBE	1
4	960143	HYDRAULIC LINE 5/8" X 36"	1
5	960639L	HYDRAULIC LINE CLAMP	2
6	928651	WELDT-BS13114 CENTER FLTG	1

Third Tube

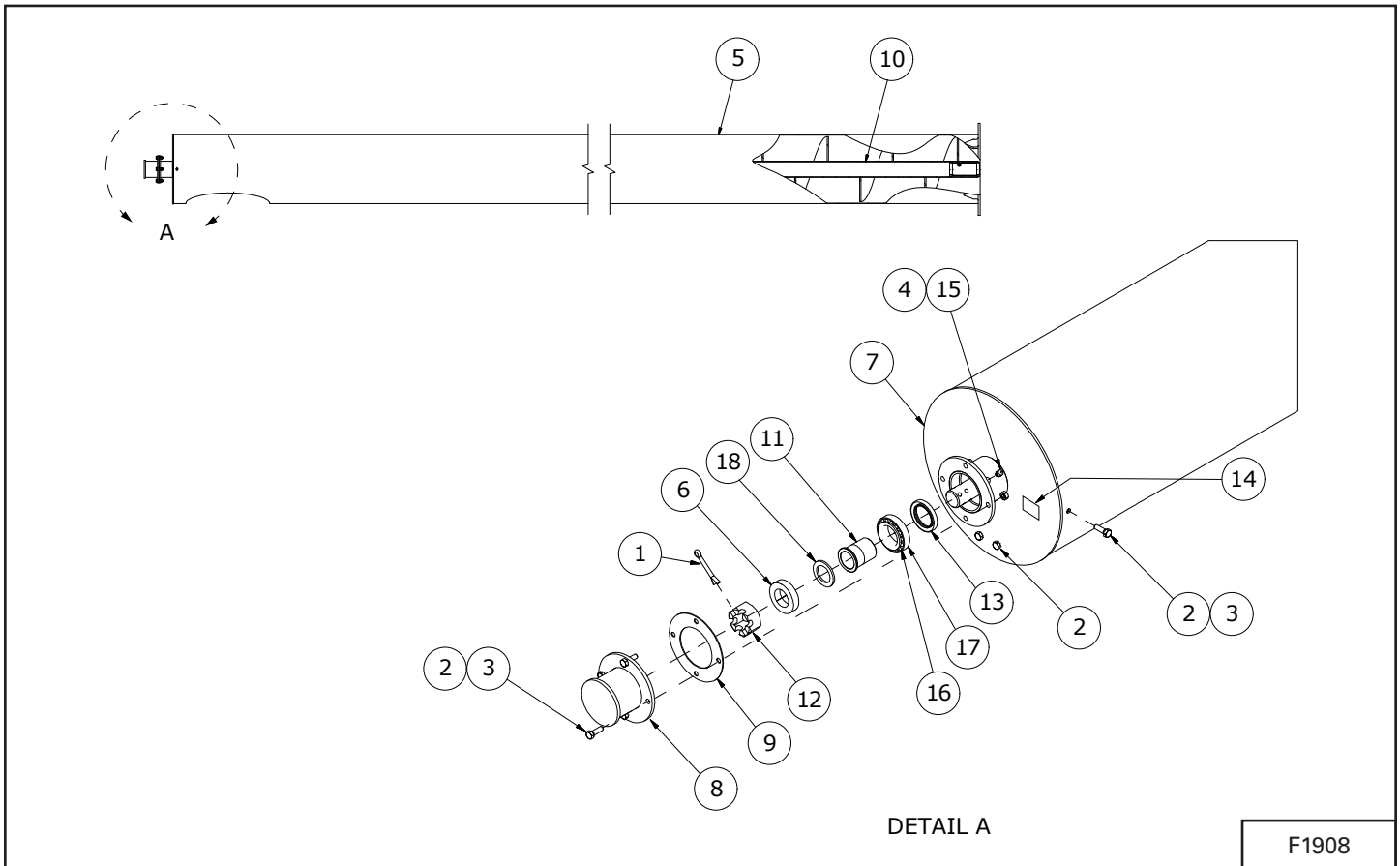

F1908

ITEM	PART NUMBER	DESCRIPTION	QTY.
1	81210	1/4" X 2" COTTER PIN (PL)	1
2	812026	5/16" X 1" HEX BOLT (PL)	8
3	812362	5/16" LOCK NUT (PL)	6
4	904902	GREASE GRADE 2	1
5	918813	WELDT-BS1385 TOPTUBE	1
6	918816L	PLATE-TOP FLTG ADJ.	1
7	918817	WELDT-TOP PLATE	1
8	918828	WELDT-TOP FLANGE CAP	1
9	920211	GASKET-FLTGTENSIONER	1
10	928652	WELDT-BS13114 TOP FLTG	1
11	960035	END BEARING SLEEVE	1
12	960037	SLOTTED HEX NUT 1 1/4" UNF	1
13	960125	OIL SEAL (CR14939)	1
14	966699	DECAL-GREASE	1
15	967164	DRIVE-IN GREASE ZERK	1
16	967708	BEARING CONE (LM29749)	1
17	967709	BEARING CUP (LM29710)	1
18	9812442	1 1/4" X 10GA FLAT WASHER (BR)	1

TUBE COMPONENTS - 95 MODELS

First Tube (Intake)

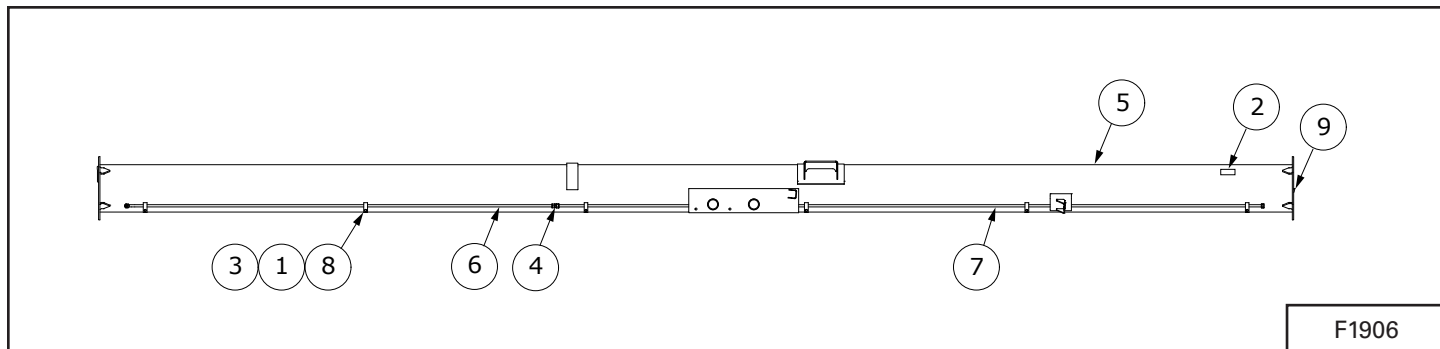

ITEM	PART NUMBER	DESCRIPTION	QTY.
1	86170	3/8" X 1" HEX BOLT GR.5 (PL)	6
2	105420	REFERENCE PLATE, BUHLER S/N	1
3	812363	3/8" LOCK NUT (PL)	6
4	812711	JIC UNION -10-10	1
5	918808	WELDT-BS1385 BOTTOMTUBE	1
6	960200	HYD LINE 5/8" OD X 9'-7"	1
7	960467	HYD LINE 5/8" X 15'-10"	1
8	960639L	HYDRAULIC LINE CLAMP	6
9	928650	WELDT-BS13114 BOTTOM FLTG	1

Second Tube

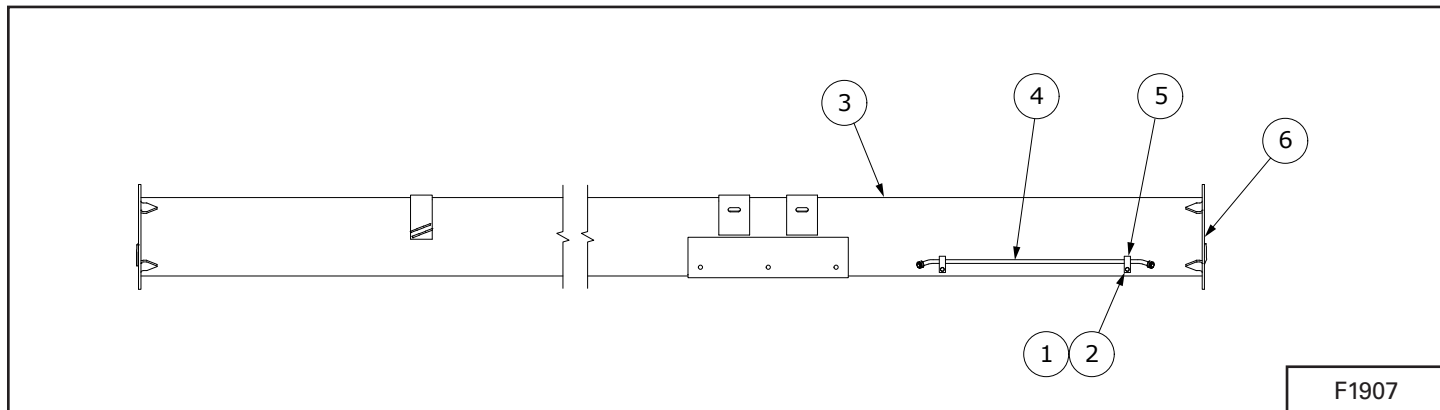

ITEM	PART NUMBER	DESCRIPTION	QTY.
1	812363	3/8" LOCK NUT (PL)	2
2	86170	3/8" X 1" HEX BOLT GR.5 (PL)	2
3	918812	WELDT-BS1385 CENTERTUBE	1
4	960143	HYDRAULIC LINE 5/8" X 36"	1
5	960639L	HYDRAULIC LINE CLAMP	2
6	928651	WELDT-BS13114 CENTER FLTG	1

Third Tube

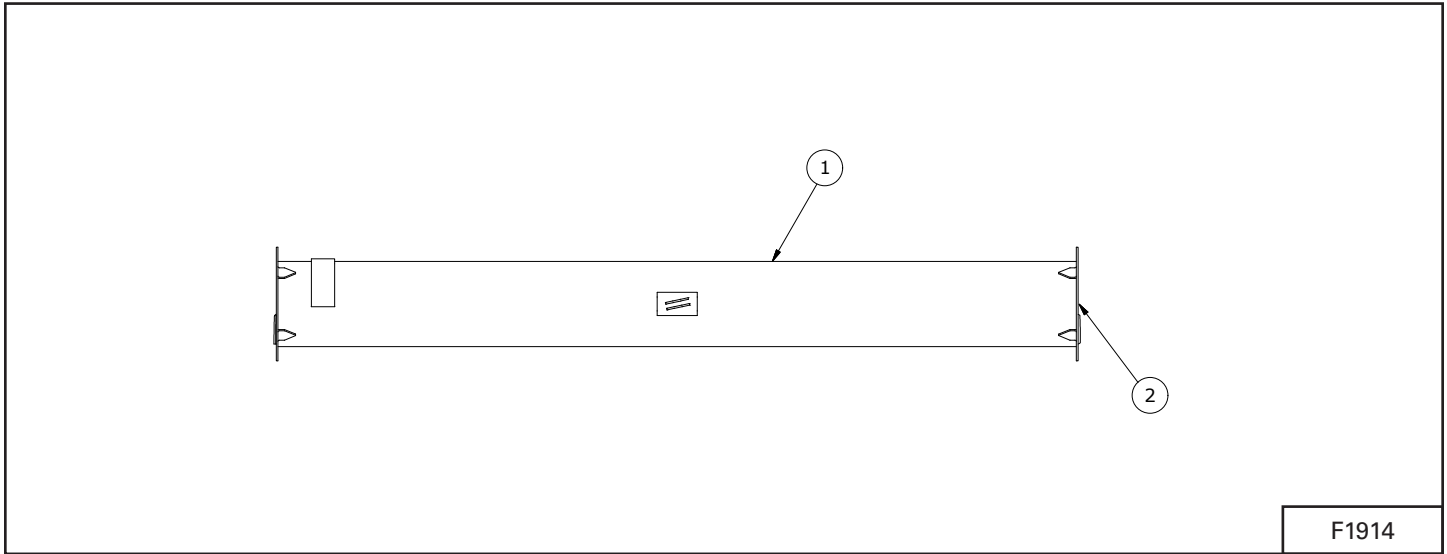

ITEM	PART NUMBER	DESCRIPTION	QTY.
1	918836	WELDT-BS13 10' EXTENSION - 95 MODELS	1
2	929701	WELDT-BS13 EXTENSION FLTG - 95 MODELS	1

Third Tube

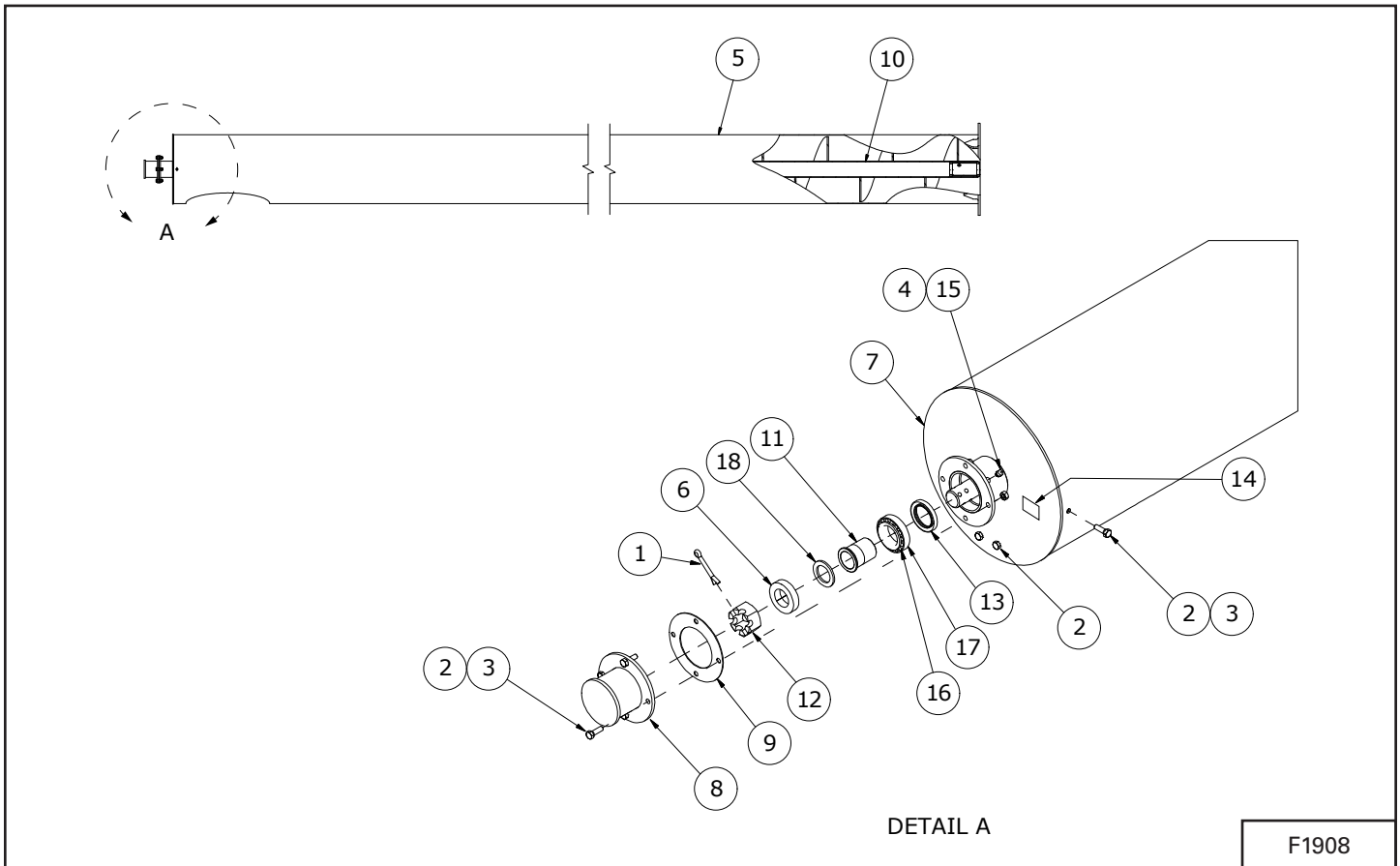

ITEM	PART NUMBER	DESCRIPTION	QTY.
1	81210	1/4" X 2" COTTER PIN (PL)	1
2	812026	5/16" X 1" HEX BOLT (PL)	8
3	812362	5/16" LOCK NUT (PL)	6
4	904902	GREASE GRADE 2	1
5	918813	WELDT-BS1385TOPTUBE	1
6	918816L	PLATE-TOP FLTG ADJ.	1
7	918817	WELDT-TOP PLATE	1
8	918828	WELDT-TOP FLANGE CAP	1
9	920211	GASKET-FLTGTENSIONER	1
10	928652	WELDT-BS13114TOP FLTG	1
11	960035	END BEARING SLEEVE	1
12	960037	SLOTTED HEX NUT 1 1/4" UNF	1
13	960125	OIL SEAL (CR14939)	1
14	966699	DECAL-GREASE	1
15	967164	DRIVE-IN GREASE ZERK	1
16	967708	BEARING CONE (LM29749)	1
17	967709	BEARING CUP (LM29710)	1
18	9812442	1 1/4" X 10GA FLAT WASHER (BR)	1

TUBE COMPONENTS - 114 MODELS

First Tube (Intake)

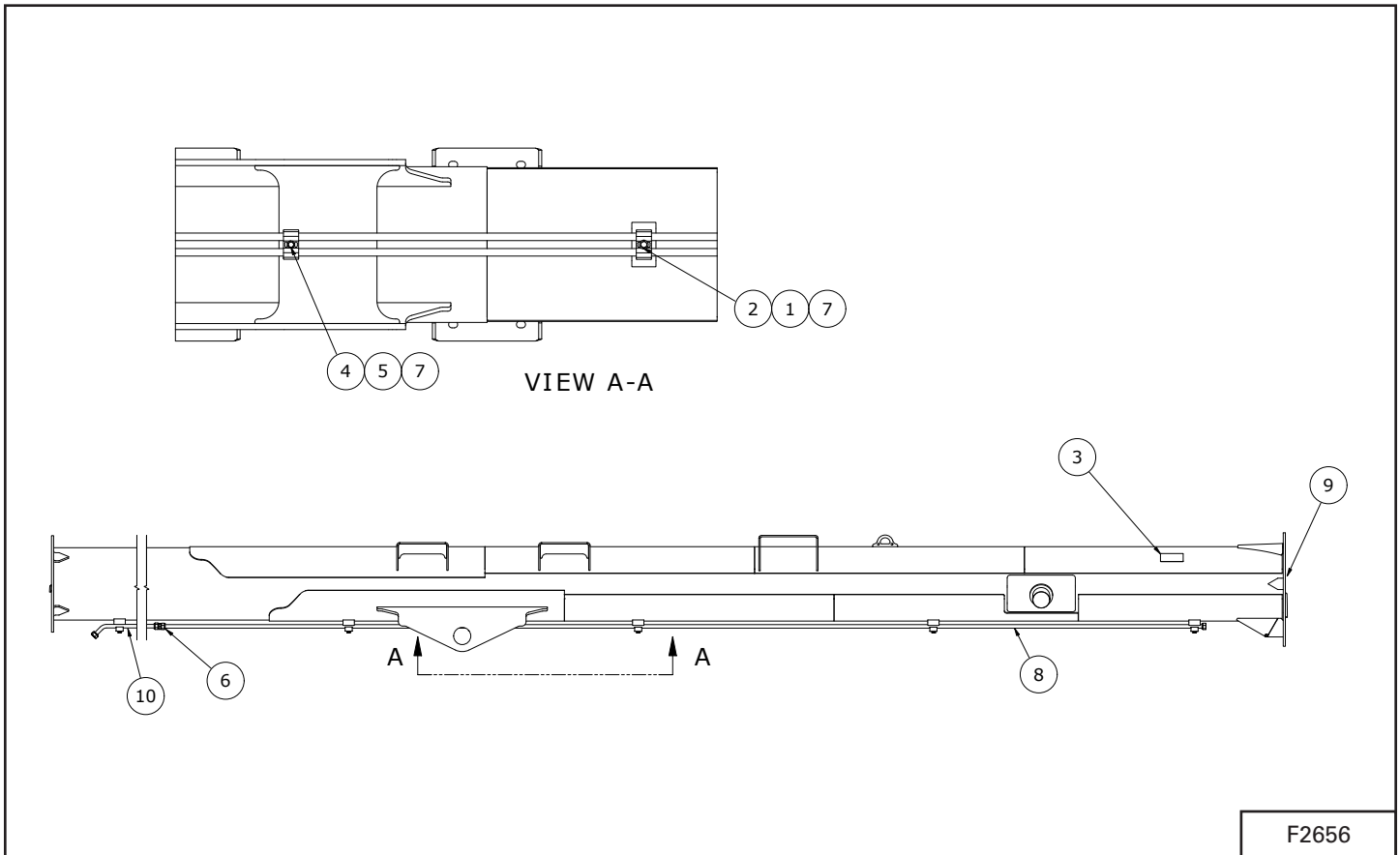

ITEM	PART NUMBER	DESCRIPTION	QTY.
1	81546	5/16" FLAT WASHER (PL)	7
2	81925	HEX BOLT 5/16" X 1 3/4" (PL)	7
3	105420	REFERENCE PLATE, BUHLER S/N	1
4	811631	1/4" X 1 1/2" HEX BOLT GR5 (PL)	1
5	812624	1/4" FLAT WASHER PL	1
6	812711	JIC UNION -10-10	2
7	931881	CLAMP-TWIN	8
8	933108	HYDRAULIC LINE 5/8"	2
9	941359	ASSY-BS13114 FIRSTTUBE (BP)	1
10	960200	HYD LINE 5/8" OD X 9'-7"	2

Second Tube

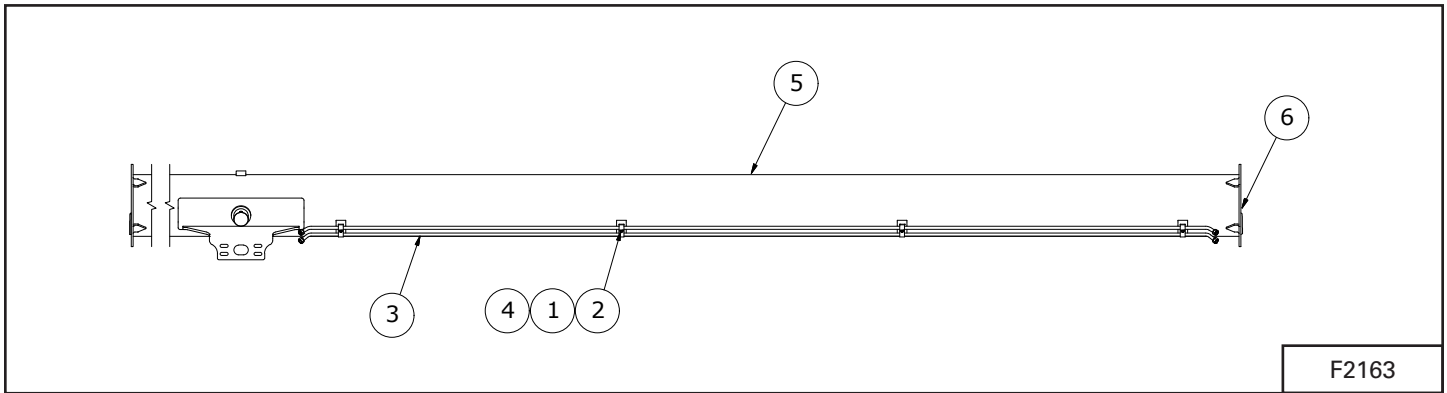

ITEM	PART NUMBER	DESCRIPTION	QTY.
1	81546	5/16" FLAT WASHER (PL)	4
2	81925	HEX BOLT 5/16" X 1 3/4" (PL)	4
3	927876	HYDRAULIC LINE 5/8"	2
4	931881	CLAMP-TWIN	4
5	926892	WELDT-BS13114 CENTERTUBE	1
6	928651	WELDT-BS13114 CENTER FLTG	1

Third Tube

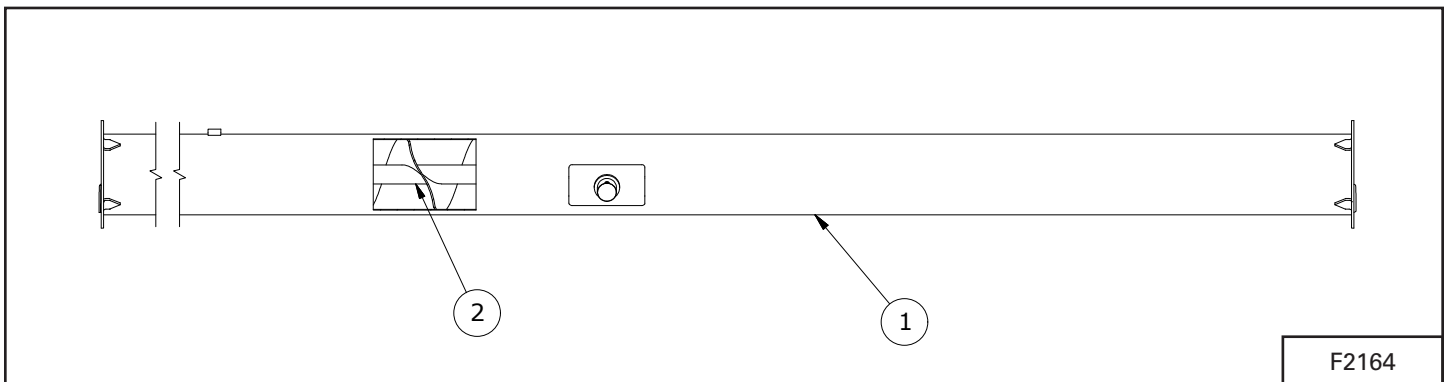

ITEM	PART NUMBER	DESCRIPTION	QTY.
1	926889	WELDT-BS13114 CENTERTUBE	1
2	928651	WELDT-BS13114 CENTER FLTG	1

Fourth Tube

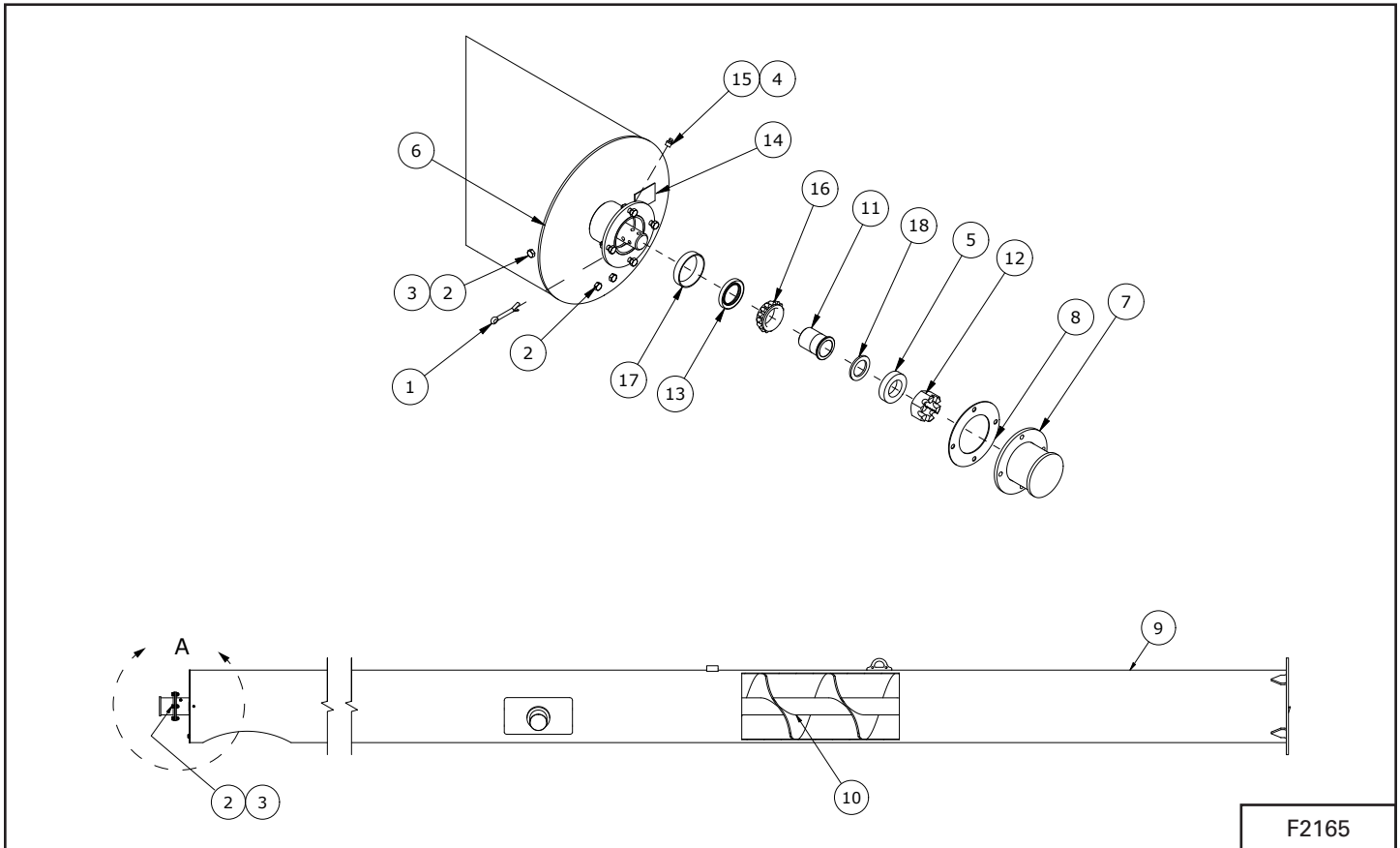

F2165

ITEM	PART NUMBER	DESCRIPTION	QTY.
1	81210	1/4" X 2" COTTER PIN (PL)	1
2	812026	5/16" X 1" HEX BOLT (PL)	8
3	812362	5/16" LOCK NUT (PL)	6
4	904902	GREASE GRADE 2	1
5	918816L	PLATE-TOP FLTG ADJ.	1
6	918817	WELDT-TOP PLATE	1
7	918828	WELDT-TOP FLANGE CAP	1
8	920211	GASKET-FLTG TENSIONER	1
9	926896	WELDT-BS13114 TOP TUBE	1
10	928652	WELDT-BS13114 TOP FLTG	1
11	960035	END BEARING SLEEVE	1
12	960037	SLOTTED HEX NUT 1 1/4" UNF	1
13	960125	OIL SEAL (CR14939)	1
14	966699	DECAL-GREASE	1
15	967164	DRIVE-IN GREASE ZERK	1
16	967708	BEARING CONE (LM29749)	1
17	967709	BEARING CUP (LM29710)	1
18	9812442	1 1/4" X 10GA FLAT WASHER (BR)	1

BRIDGING - 114 MODELS

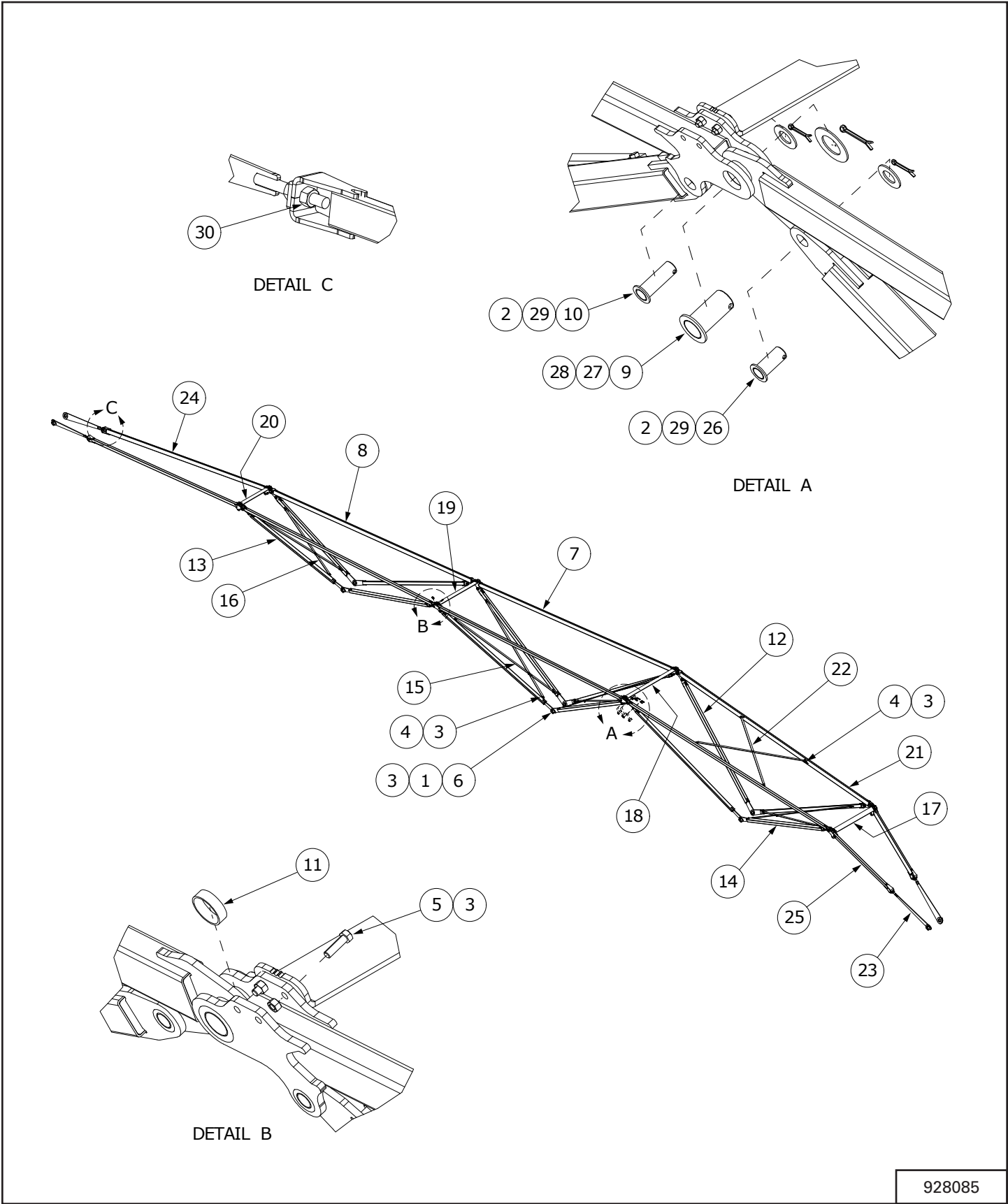

928085

ITEM	PART NUMBER	DESCRIPTION	QTY.
1	811691	1/2" X 4 1/2" HEX BOLT (PL)	10
2	81210	1/4" X 2" COTTER PIN (PL)	12
3	812364	1/2" LOCK NUT (PL)	51
4	84277	1/2" X 1 1/2" HEX BOLT (PL)	25
5	87553	1/2" X 1.75" HEX BOLT UNC GR5 (PL)	16
6	905736	UNDERCARR PIN SLEEVE	10
7	927662	WELDT-TRUSS BEAM	2
8	927766	WELDT-TRUSS BEAM	2
9	927850	WELDT-TRUSS PIN	8
10	927852	WELDT-TRUSS PIN	4
11	927857	TUBE-TRUSS SPACER	16
12	928093	WELDT-TRUSS BEAM	4
13	928096	WELDT-TRUSS BEAM	2
14	928101	WELDT-TRUSS BEAM	6
15	928103	PLATE-CROSS BRACE	6
16	928118L	PLATE-CROSS BRACE	2
17	928121	BRKT-TRUSS SUPPORT	1
18	928122	BRKT-TRUSS SUPPORT	1
19	928123	BRKT-TRUSS SUPPORT	1
20	928124	BRKT-TRUSS SUPPORT	1
21	929364	WELDT-TRUSS BEAM	2
22	929367	BRKT-CROSS BRACE	2
23	930625	WELDT-TRUSS FASTENER	4
24	930628	WELDT-TRUSS BEAM	2
25	930629	WELDT-TRUSS BEAM	2
26	960108	LIFT ARM CLEVIS PIN WELDT 1.250" DIA	8
27	967153	2" X 10GA NARROW RIM WASHER (PL)	8
28	967162	5/16" X 3" COTTER PIN (PL)	8
29	9812487	1 1/4" X 10GA NARROW RIM WASHER (PL)	12
30	EZBN125	NUT HEX 1-1/4 NC GR2 ZNCR	8

INPUT BOX - 70, 85, 95 MODELS

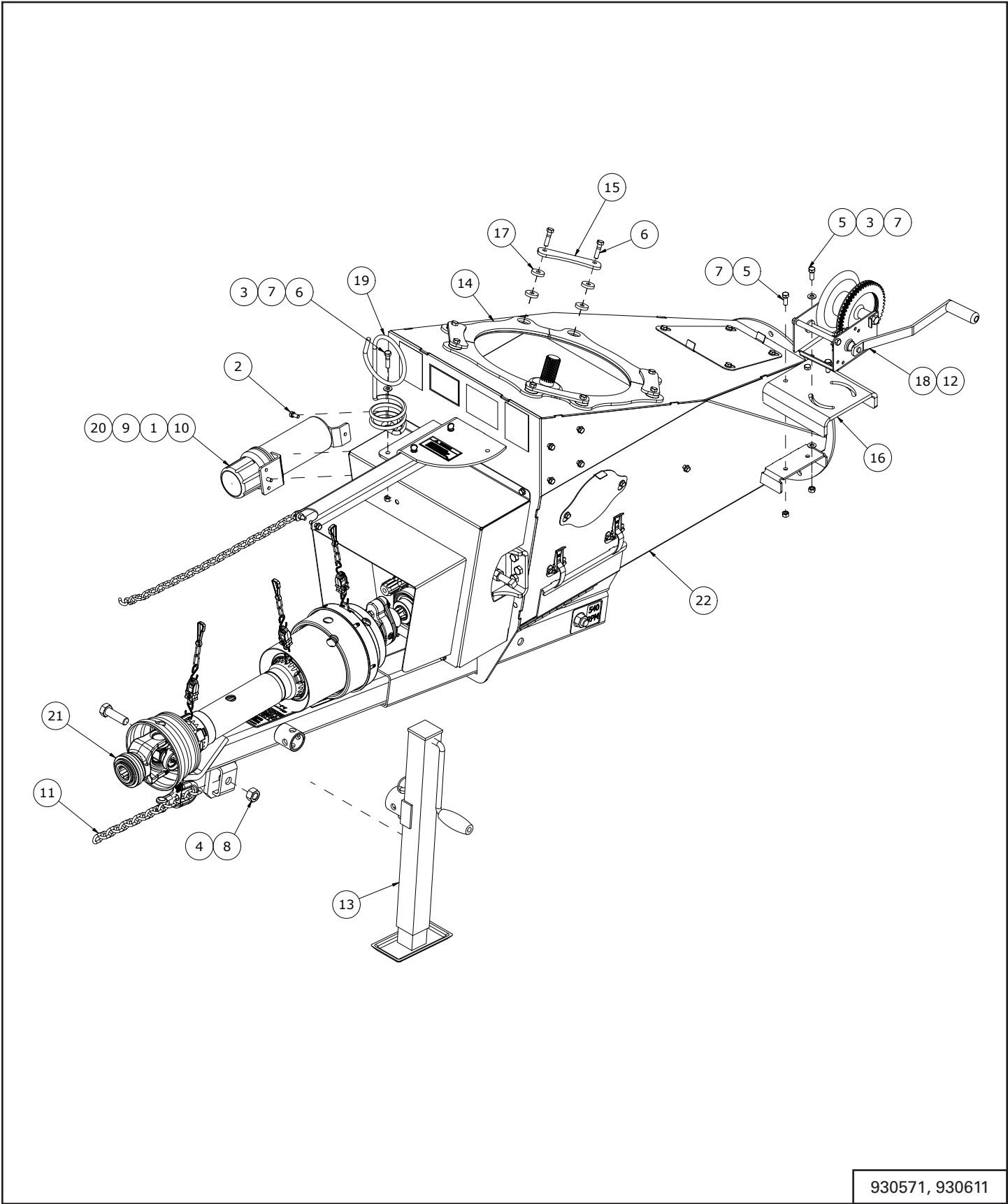

930571, 930611

ITEM	PART NUMBER	DESCRIPTION	QTY.
1	81210	1/4" X 2" COTTER PIN (PL)	1
2	81549	5/16" X 3/4" HEX BOLT (PL)	2
3	84039	WASHER - 3/8" SAE FLAT (PL)	7
4	84346	3/4" X 2 1/2" HEX BOLT (PL)	1
5	86170	3/8" X 1" HEX BOLT GR.5 (PL)	5
6	811792	3/8" X 1 1/2" HEX BOLT GR.5 (PL)	9
7	812363	3/8" LOCK NUT (PL)	6
8	812365	3/4" LOCK NUT (PL)	1
9	814433	WARRANTY REGISTRATION MANUAL	1
10	909277	MANUAL HOLDER 3 1/2" X 12"	1
11	910287	HOOK & SAFETY CHAIN ASSEMBLY	1
12	910506	CABLE HYD WINCH ASSY MA	1
13	914426	5000 LB JACK	1
14	917596	SPACER-INTAKE	4
15	917707L	PLATE-RING CLAMP	4
16	919570	BRKT-MANUAL WINCH MOUNT	1
17	960494	1/4"W X 13/32"ID X 1 1/4"OD WASHER (PL)	16
18	961888	BRAKE WINCH	1
19	966314	HYDRAULIC HOSE HOLDER	1
20	967458	ADMA PTO SAFETY MANUAL	1
21	F2296	PTO - 1 3/8 X 6 U-JOINT - 1 3/8 X 6 CV - 1370	1
	F2306	PTO - 1 3/8 X 6 U-JOINT - 1 3/8 X 6 CV - 1385/1395	1
22	F2767	ASSY-BS13 INPUT BOX	1

INPUT BOX DRIVE - 70, 85, 95 MODELS

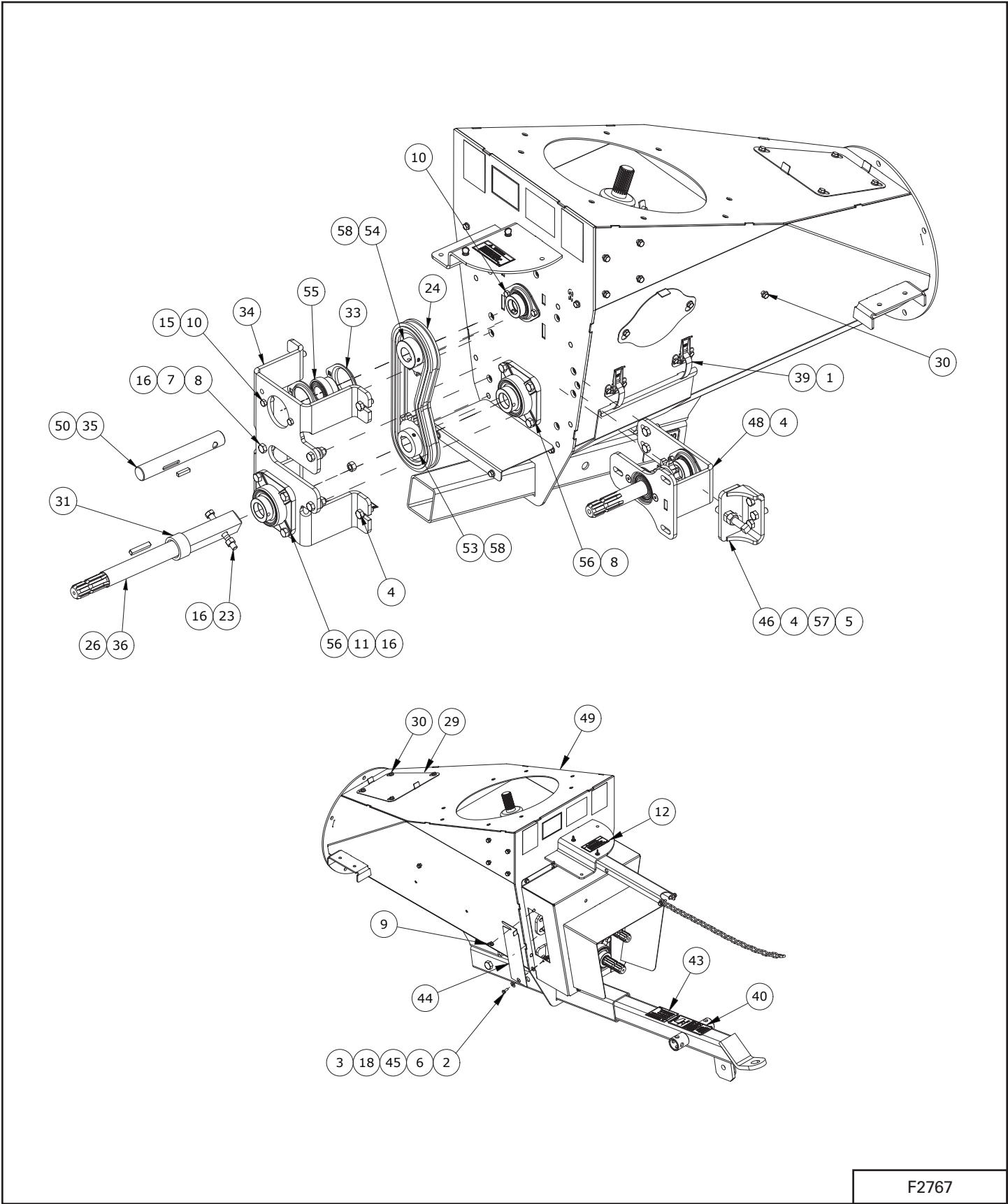

F2767

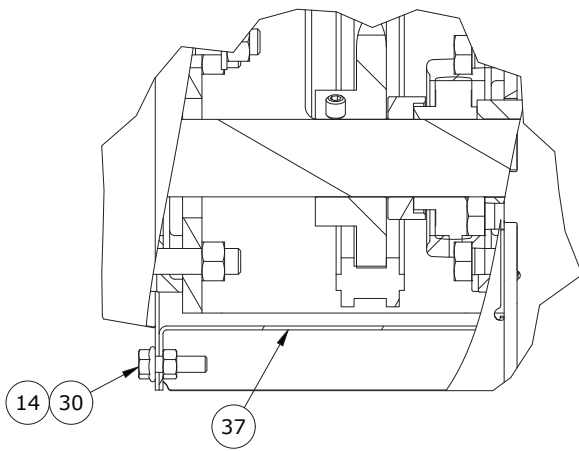
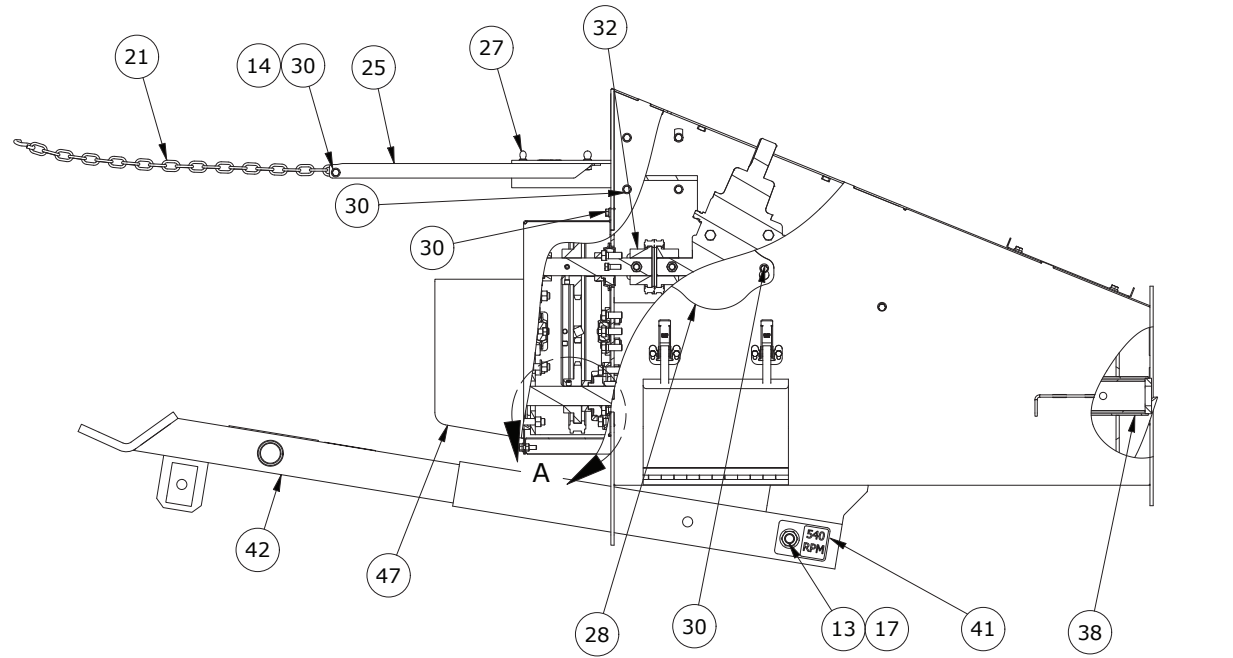

DETAIL A

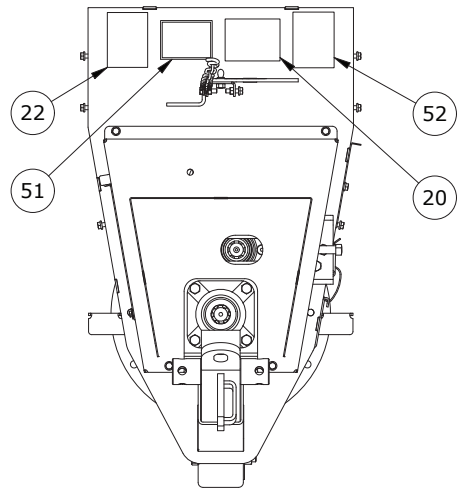

ITEM	PART NUMBER	DESCRIPTION	QTY.
1	81523	1/4" X 1/2" HEX BOLT (PL)	4
2	81525	1/4" X 3/4" HEX BOLT (PL)	1
3	81544	1/4" HEX NUT (PL)	1
4	81620	1/2" X 1 1/4" HEX BOLT PL	9
5	81676	5/8" HEX NUT (PL)	1
6	84039	WASHER - 3/8" SAE FLAT (PL)	1
7	84048	1/2" SAE FLAT WASHER (PL)	3
8	84277	1/2" X 1 1/2" HEX BOLT (PL)	7
9	84500	NUT WING 0.25NC GR2 PL	1
10	86170	3/8" X 1" HEX BOLT GR.5 (PL)	4
11	87553	1/2" X 1.75" HEX BOLT UNC GR5 (PL)	4
12	108431	DECAL WARNING-CHECK PTO SHAFT	1
13	811790	3/4" X 4 1/2" HEX BOLT GR5 (PL)	1
14	812362	5/16" LOCK NUT (PL)	4
15	812363	3/8" LOCK NUT (PL)	2
16	812364	NUT-HEX-GR5-(ZT)-1/2_13	10
17	812365	3/4" LOCK NUT (PL)	1
18	812624	1/4" FLAT WASHER PL	1
19	904578	GEAR OIL - SAE 75W-90, SYNTHETIC	0.7L
20	904585	DECAL-DANGER ROTATING DRIVELINE	1
21	909703	PTO HOLDER CHAIN ASSY	1
22	909745	DECAL-DANGER ELECTROCUTION	1
23	910025	1/2" X 4" GR8 HEX BOLT (PL)	3
24	910989	ROLLER CHAIN - 80H X 36 PITCHES	1
25	911111	PTO HOLDER ARM WELDT	1
26	911161	KEY 3/8"SQ. X 58mm	1
27	911943	3/8" X 3/4" THUMB SCREW (PL)	2
28	917446	COVER-GEARBOX ACCESS	1
29	917447	COVER-TOP ACCESS	1
30	917483	BOLT FL 0.313NC X 1.00 GR5 PL	24
31	918913	TUBE-M1000 SHAFT SPACER	1
32	919354	ASSY-COUPLING H5018	1
33	919368	BEARING FLANGE-2 BOLT (PL)	4
34	919377	BRKT-BEARING MOUNT	1
35	919387	SHAFT-TOP CHAIN DRIVE	1
36	919389	SHAFT-FLTG CHAIN DRIVE	1
37	919396	BRKT-LOWER CHAIN GUARD	1
38	928649	WELDT-INPUT BOX FLTG	1
39	931901	LATCH-SLOTTED	2
40	933285	DECAL-WARNING, MAXIMUM TOWING SPEED	1
41	936775	DECAL-540 RPM HITCH POSITION	1

ITEM	PART NUMBER	DESCRIPTION	QTY.
42	937889	WELDT-BS13 HITCH	1
43	937890	DECAL-RECOMMENDED HITCH POSITION	1
44	941879	BRKT-ACCESS DOOR	1
45	942162	WASHER-1/4" OVERSIZED (PL)	1
46	943720	TENSIONING BOLT BRKT - WLDT	1
47	943726	WELDT-PTO SHIELD	1
48	944730	ASSY-IDLER	1
49	944733	WELDT-INPUT BOX BS13	1
50	960180	U-JOINT & SPROCKET KEY .313"SQ. X 1.375"	1
51	960371	3" X 4" LABEL INPUT BOX	1
52	960569	DECAL-DANGER UPENDING	1
53	960719	H80B15 SPROCKET (1.5" BORE)	1
54	961041	H80B15 SPROCKET (1.375" BORE)	1
55	965917	1 3/8" BEARING	2
56	968632	1 1/2" X 4-BOLT HSG DUCTILE W/BRG	2
57	968898	5/8" X 4" SQ HD SET SCREW (BR)	1
58	988999	3/8"Ø X 3/8" SOCKET SET SCREW (BR)	4

INPUT BOX - 114 MODELS

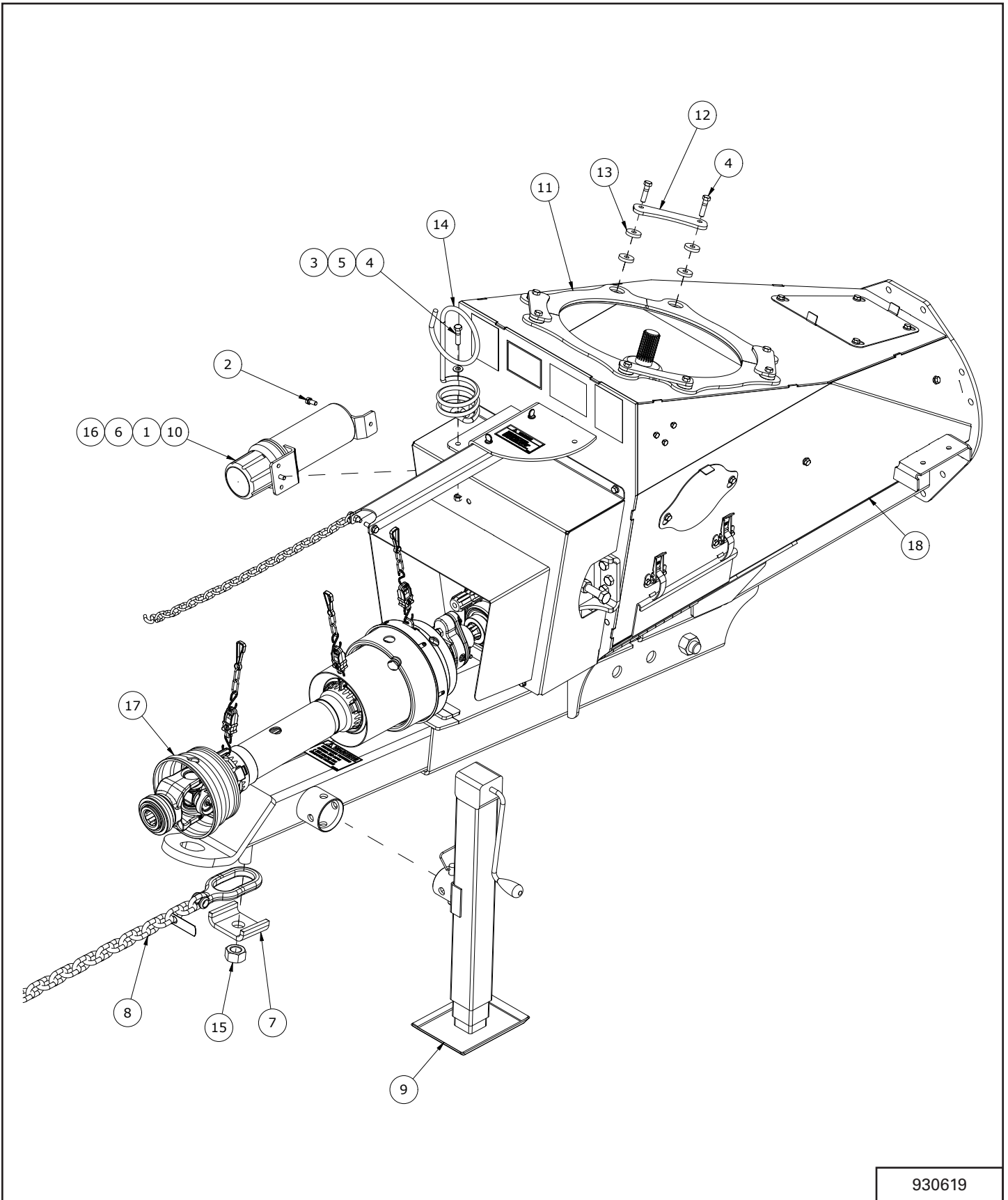

930619

ITEM	PART NUMBER	DESCRIPTION	QTY.
1	81210	1/4" X 2" COTTER PIN (PL)	1
2	81549	5/16" X 3/4" HEX BOLT (PL)	2
3	84039	WASHER - 3/8" SAE FLAT (PL)	1
4	811792	3/8" X 1 1/2" HEX BOLT GR.5 (PL)	9
5	812363	3/8" LOCK NUT (PL)	1
6	814433	WARRANTY REGISTRATION MANUAL	1
7	904580	SAFETY CHAIN PLATE	1
8	906284	HOOK & SAFETY CHAIN ASSEMBLY	1
9	909195	JACK	1
10	909277	MANUAL HOLDER 3 1/2" X 12"	1
11	917596	SPACER-INTAKE	4
12	917707L	PLATE-RING CLAMP	4
13	960494	1/4"W X 13/32"ID X 1 1/4"OD WASHER (PL)	16
14	966314	HYDRAULIC HOSE HOLDER	1
15	967148	1" LOCK NUT (PL)	1
16	967458	ADMA PTO SAFETY MANUAL	1
17	F2306	PTO - 1 3/8 X 6 U-JOINT - 1 3/8 X 6 CV	1
18	F2769	ASSY-BS13 INPUT BOX	1
19	FK428	OPERATIONS/PARTS MANUAL-13" BACKSAVER AUGER	1
20	FK429	ASSEMBLY MANUAL-13" BACKSAVER AUGER	1

INPUT BOX DRIVE - 114 MODELS

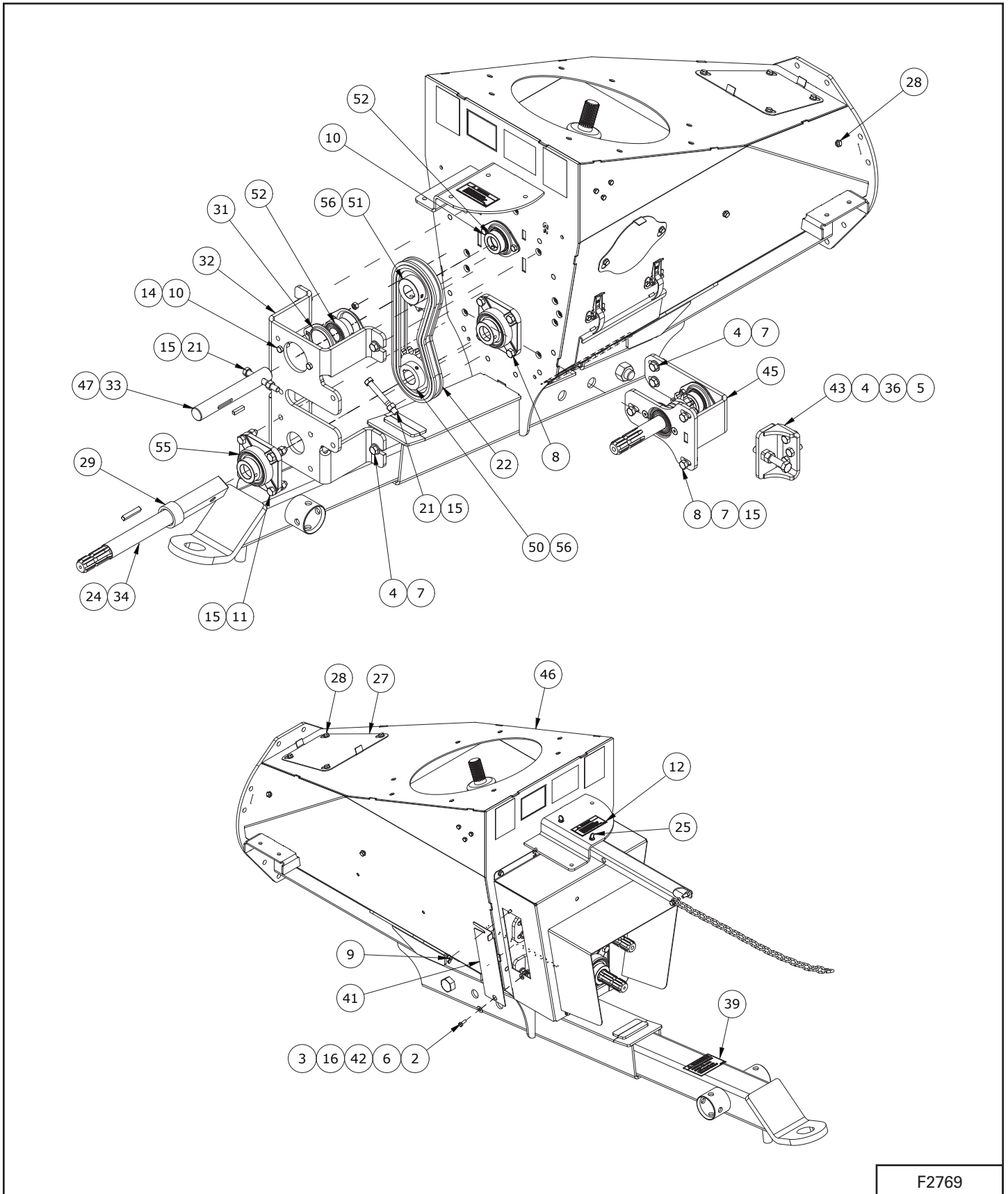

F2769

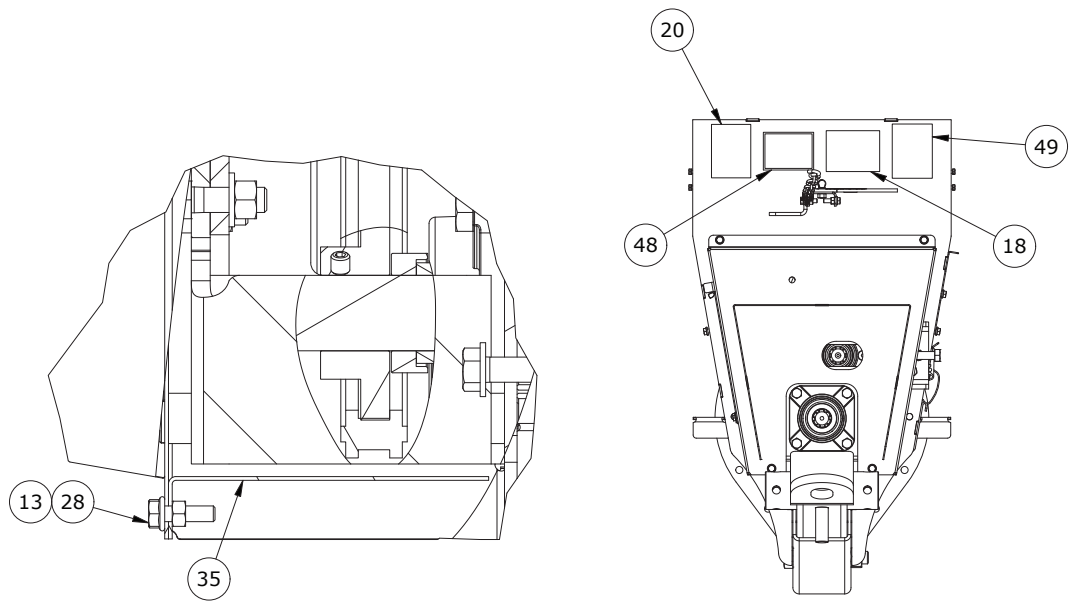
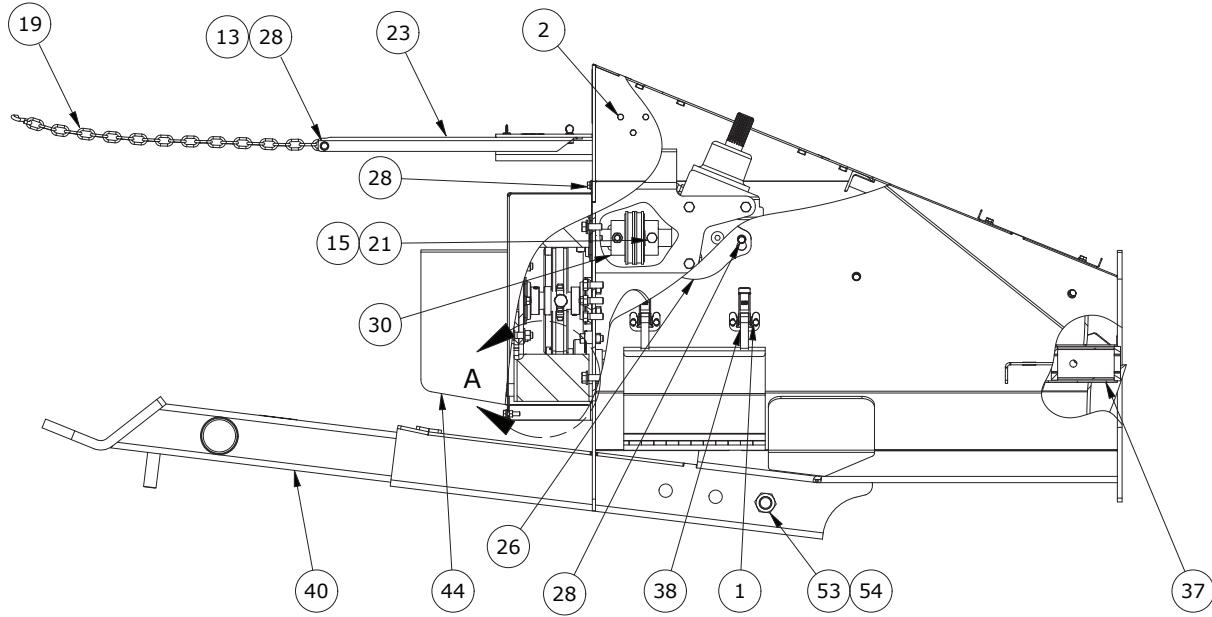

DETAIL A

ITEM	PART NUMBER	DESCRIPTION	QTY.
1	81523	1/4" X 1/2" HEX BOLT (PL)	4
2	81525	1/4" X 3/4" HEX BOLT (PL)	7
3	81544	1/4" HEX NUT (PL)	1
4	81620	1/2" X 1 1/4" HEX BOLT PL	9
5	81676	5/8" HEX NUT (PL)	1
6	84039	WASHER - 3/8" SAE FLAT (PL)	1
7	84048	1/2" SAE FLAT WASHER (PL)	9
8	84277	1/2" X 1 1/2" HEX BOLT (PL)	7
9	84500	NUT WING 0.25NC GR2 PL	1
10	86170	3/8" X 1" HEX BOLT GR.5 (PL)	4
11	87553	1/2" X 1.75" HEX BOLT UNC GR5 (PL)	4
12	108431	DECAL WARNING-CHECK PTO SHAFT	1
13	812362	5/16" LOCK NUT (PL)	4
14	812363	3/8" LOCK NUT (PL)	2
15	812364	NUT-HEX-GR5-(ZT)-1/2_13	10
16	812624	1/4" FLAT WASHER PL	1
17	904578	GEAR OIL - SAE 75W-90 SYNTHETIC	0.75L
18	904585	DECAL-DANGER ROTATING DRIVELINE	1
19	909703	PTO HOLDER CHAIN ASSY	1
20	909745	DECAL-DANGER ELECTROCUTION	1
21	910025	1/2" X 4" GR8 HEX BOLT (PL)	3
22	910989	ROLLER CHAIN - 80H X 36 PITCHES	1
23	911111	PTO HOLDER ARM WELDT	1
24	911161	KEY 3/8"SQ. X 58mm	1
25	911943	3/8" X 3/4" THUMB SCREW (PL)	2
26	917446	COVER-GEARBOX ACCESS	1
27	917447	COVER-TOP ACCESS	1
28	917483	BOLT FL 0.313NC X 1.00 GR5 PL	18
29	918913	TUBE-M1000 SHAFT SPACER	1
30	919354	ASSY-COUPLING H5018	1
31	919368	BEARING FLANGE-2 BOLT (PL)	4
32	919377	BRKT-BEARING MOUNT	1
33	919387	SHAFT-TOP CHAIN DRIVE	1
34	919389	SHAFT-FLTG CHAIN DRIVE	1
35	919396	BRKT-LOWER CHAIN GUARD	1
36	927733	5/8" X 4" GR5 HEX BOLT (PL) FULL THREAD	1
37	928649	WELDT-INPUT BOX FLTG	1
38	931901	LATCH-SLOTTED	2
39	933285	DECAL-WARNING, MAXIMUM TOWING SPEED	1
40	941137	WELDT-HITCH TUBE BS13	1
41	941879	BRKT-ACCESS DOOR	1

ITEM	PART NUMBER	DESCRIPTION	QTY.
42	942162	WASHER-1/4" OVERSIZED (PL)	1
43	943720	TENSIONING BOLT BRKT - WLDT	1
44	943726	WELDT-PTO SHIELD	1
45	944730	ASSY-IDLER	1
46	944735	WELDT-INPUT BOX BS13	1
47	960180	U-JOINT & SPROCKET KEY .313"SQ. X 1.375"	1
48	960371	3" X 4" LABEL INPUT BOX	1
49	960569	DECAL-DANGER UPENDING	1
50	960719	H80B15 SPROCKET (1.5" BORE)	1
51	961041	H80B15 SPROCKET (1.375" BORE)	1
52	965917	1 3/8" BEARING	2
53	967148	1" LOCK NUT (PL)	1
54	967229	1" X 6" HEX BOLT (PL)	1
55	968632	1 1/2" X 4-BOLT HSG DUCTILE W/BRG	2
56	988999	3/8"Ø X 3/8" SOCKET SET SCREW (BR)	4

IDLER

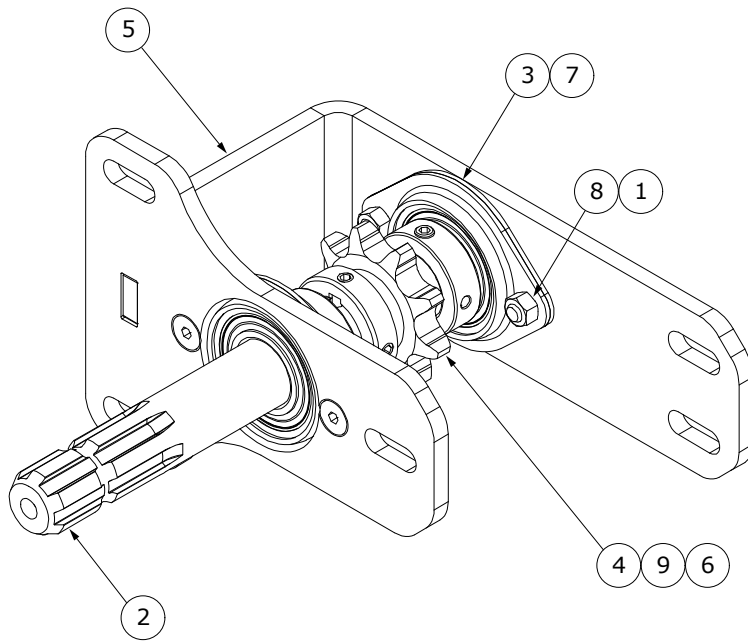

944730

ITEM	PART NUMBER	DESCRIPTION	QTY.
1	812363	3/8" LOCK NUT (PL)	4
2	919363	SHAFT-REVERSE PTO	1
3	919368	BEARING FLANGE-2 BOLT (PL)	4
4	919438	H80B9 SPROCKET (1.375 BORE)	1
5	944729	WELDT-IDLER	1
6	960180	U-JOINT & SPROCKET KEY .313"SQ. X 1.375"	1
7	965917	1 3/8" BEARING	2
8	967431	FLAT HEAD SOCKET CAP SCREW 0.375" X 1.00"	4
9	988999	3/8"0 X 3/8" SOCKET SET SCREW (BR)	2

INPUT BOX M1000 - 70, 85, 95 MODELS

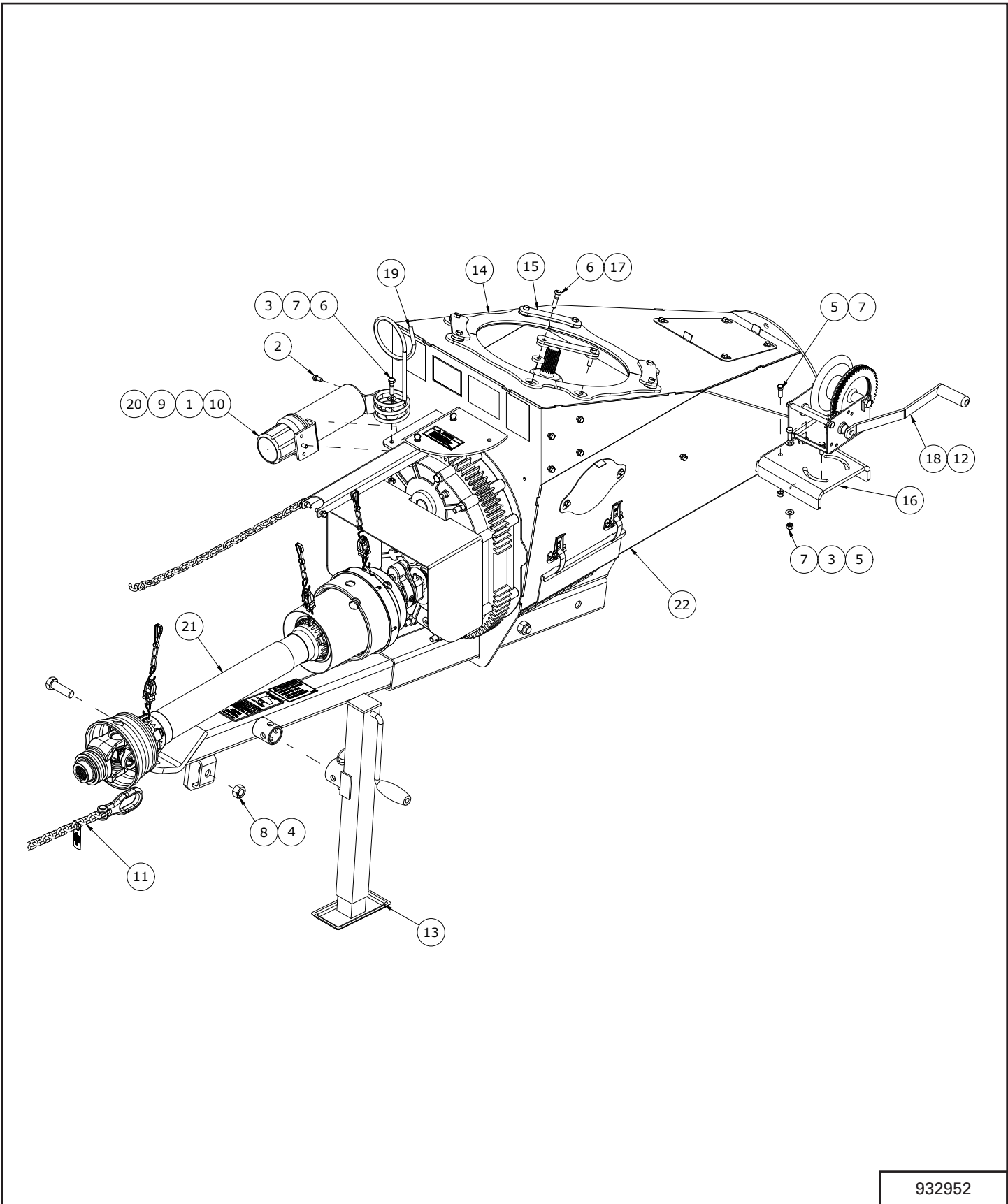

932952

ITEM	PART NUMBER	DESCRIPTION	QTY.
1	81210	1/4" X 2" COTTER PIN (PL)	1
2	81549	5/16" X 3/4" HEX BOLT (PL)	2
3	84039	WASHER - 3/8" SAE FLAT (PL)	7
4	84346	3/4" X 2 1/2" HEX BOLT (PL)	1
5	86170	3/8" X 1" HEX BOLT GR.5 (PL)	5
6	811792	3/8" X 1 1/2" HEX BOLT GR.5 (PL)	9
7	812363	3/8" LOCK NUT (PL)	6
8	812365	3/4" LOCK NUT (PL)	1
9	814433	WARRANTY REGISTRATION MANUAL	1
10	909277	MANUAL HOLDER 3 1/2" X 12"	1
11	910287	HOOK & SAFETY CHAIN ASSEMBLY	1
12	910506	CABLE HYD WINCH ASSY MA	1
13	914426	5000 LB JACK	1
14	917596	SPACER-INTAKE	4
15	917707L	PLATE-RING CLAMP	4
16	919570	BRKT-MANUAL WINCH MOUNT	1
17	960494	1/4"W X 13/32"ID X 1 1/4"OD WASHER (PL)	16
18	961888	BRAKE WINCH	1
19	966314	HYDRAULIC HOSE HOLDER	1
20	967458	ADMA PTO SAFETY MANUAL	1
21	F2295	PTO-1 3/8 X 21 U-JOINT - 1 3/8 X 21 CV	1
22	F2768	ASSY-BS13 INPUT BOX M1000 GEARBOX	1

INPUT BOX M1000 DRIVE - 70, 85, 95 MODELS

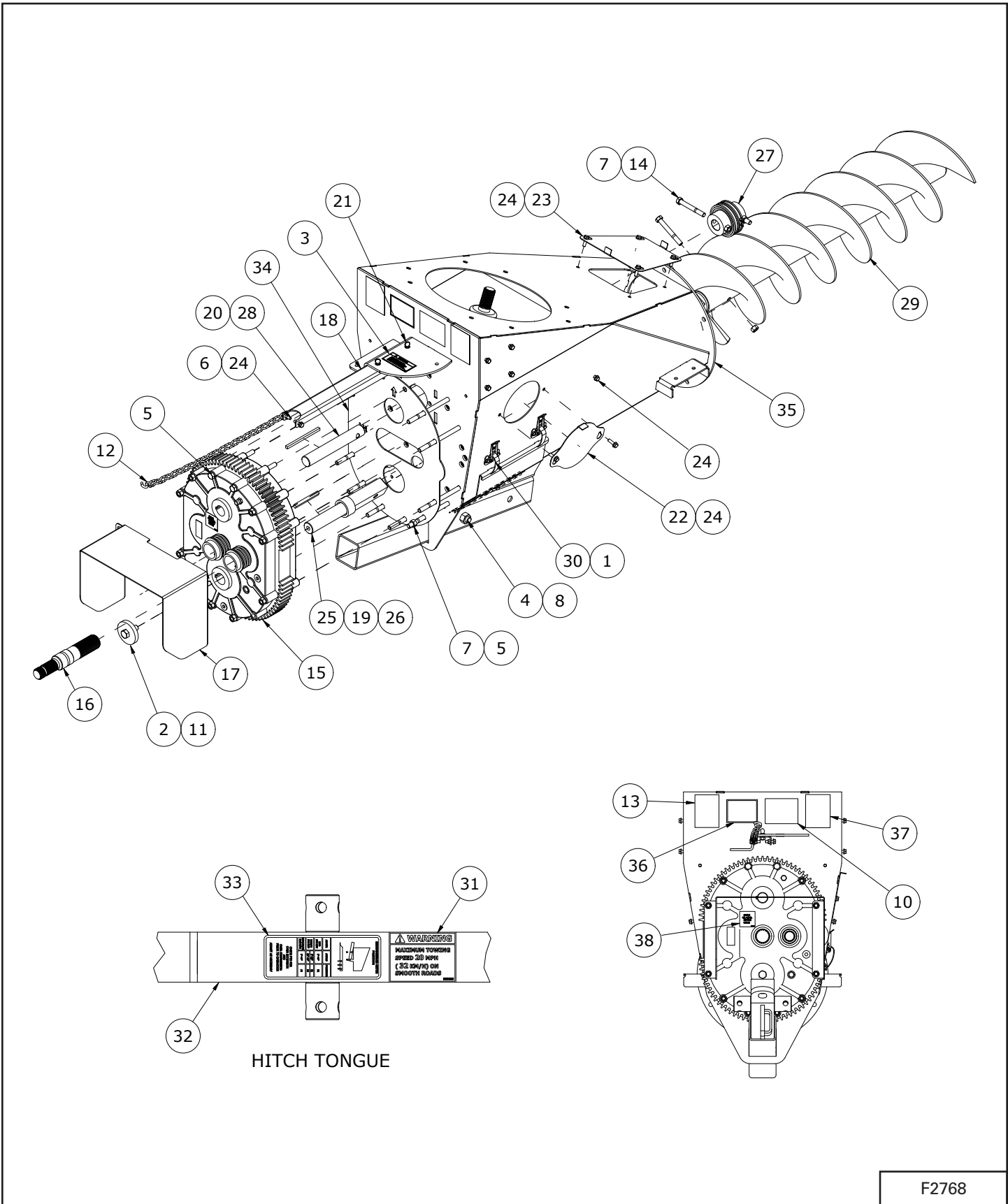

F2768

ITEM	PART NUMBER	DESCRIPTION	QTY.
1	81523	1/4" X 1/2" HEX BOLT (PL)	4
2	84270	5/8" X 1 3/4" HEX BOLT (PL)	1
3	108431	DECAL WARNING-CHECK PTO SHAFT	1
4	811790	3/4" X 4 1/2" HEX BOLT GR5 (PL)	1
5	811829	1/2" X 7" HEX BOLT (PL)	12
6	812362	5/16" LOCK NUT (PL)	2
7	812364	NUT-HEX-GR5-(ZT)-1/2_13	13
8	812365	3/4" LOCK NUT (PL)	1
9	904578	GEAR OIL - SAE 75W-90, SYNTHETIC	3.25L
10	904585	DECAL-DANGER ROTATING DRIVELINE	1
11	906073L	WASHER - INPUT BOX SHFT	1
12	909703	PTO HOLDER CHAIN ASSY	1
13	909745	DECAL-DANGER ELECTROCUTION	1
14	910025	1/2" X 4" GR8 HEX BOLT (PL)	3
15	910927	GEARBOX-M1000 HELICAL	1
16	910947	M1000 SPLINE STUB SHAFT	1
17	911083	M1000 HGBOX GUARD	1
18	911111	PTO HOLDER ARM WELDT	1
19	911130	KEY 3/8"SQ X 3.94"	1
20	911163	KEY 5/16"SQ. X 140mm	1
21	911943	3/8" X 3/4" THUMB SCREW (PL)	2
22	917446	COVER-GEARBOX ACCESS	1
23	917447	COVER-TOP ACCESS	1
24	917483	BOLT FL 0.313NC X 1.00 GR5 PL	18
25	918820	BAR-M1000 SHAFT	1
26	918913	TUBE-M1000 SHAFT SPACER	1
27	919354	ASSY-COUPLING H5018	1
28	919359	SHAFT-M1000 GEARBOX	1
29	928649	WELDT-INPUT BOX FLTG	1
30	931901	LATCH-SLOTTED	2
31	933285	DECAL-WARNING, MAXIMUM TOWING SPEED	1
32	937889	WELDT-BS13 HITCH	1
33	937890	DECAL-RECOMMENDED HITCH POSITION	1
34	943813L	HELICAL GEARBOX PLATE	1
35	944733	WELDT-INPUT BOX BS13	1
36	960371	3" X 4" LABEL INPUT BOX	1
37	960569	DECAL-DANGER UPENDING	1
38	967388	CHECK OIL DECAL	1

INPUT BOX M1000 - 114 MODELS

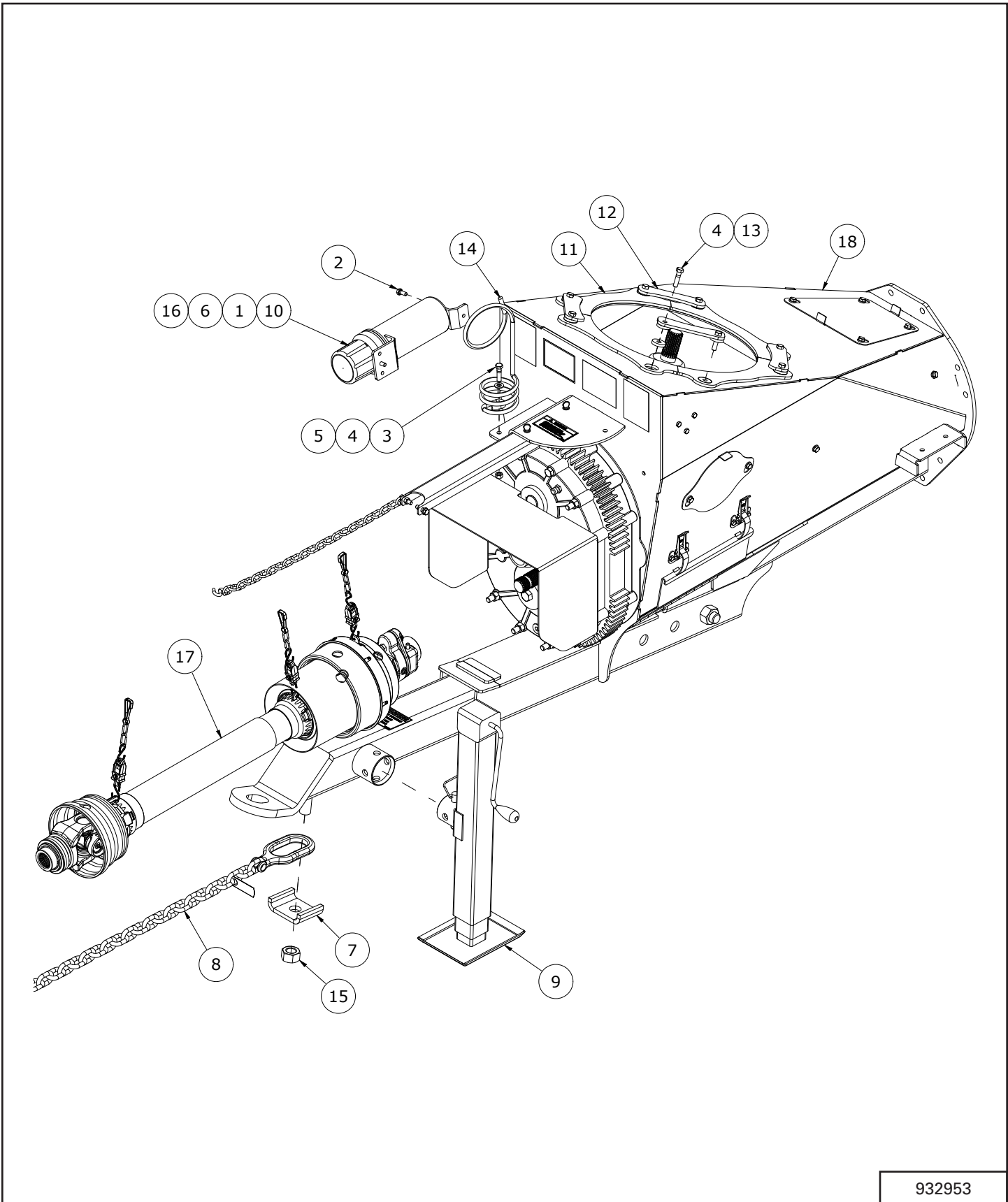

932953

ITEM	PART NUMBER	DESCRIPTION	QTY.
1	81210	1/4" X 2" COTTER PIN (PL)	1
2	81549	5/16" X 3/4" HEX BOLT (PL)	2
3	84039	WASHER - 3/8" SAE FLAT (PL)	1
4	811792	3/8" X 1 1/2" HEX BOLT GR.5 (PL)	9
5	812363	3/8" LOCK NUT (PL)	1
6	814433	WARRANTY REGISTRATION MANUAL	1
7	904580	SAFETY CHAIN PLATE	1
8	906284	HOOK & SAFETY CHAIN ASSEMBLY	1
9	909195	JACK	1
10	909277	MANUAL HOLDER 3 1/2" X 12"	1
11	917596	SPACER-INTAKE	4
12	917707L	PLATE-RING CLAMP	4
13	960494	1/4"W X 13/32"ID X 1 1/4"OD WASHER (PL)	16
14	966314	HYDRAULIC HOSE HOLDER	1
15	967148	1" LOCK NUT (PL)	1
16	967458	ADMA PTO SAFETY MANUAL	1
17	F2295	PTO-1 3/8 X 21 U-JOINT - 1 3/8 X 21 CV	1
18	F2770	ASSY-BS13114 INPUT BOX M1000 GEARBOX	1

INPUT BOX M1000 DRIVE - 114 MODELS

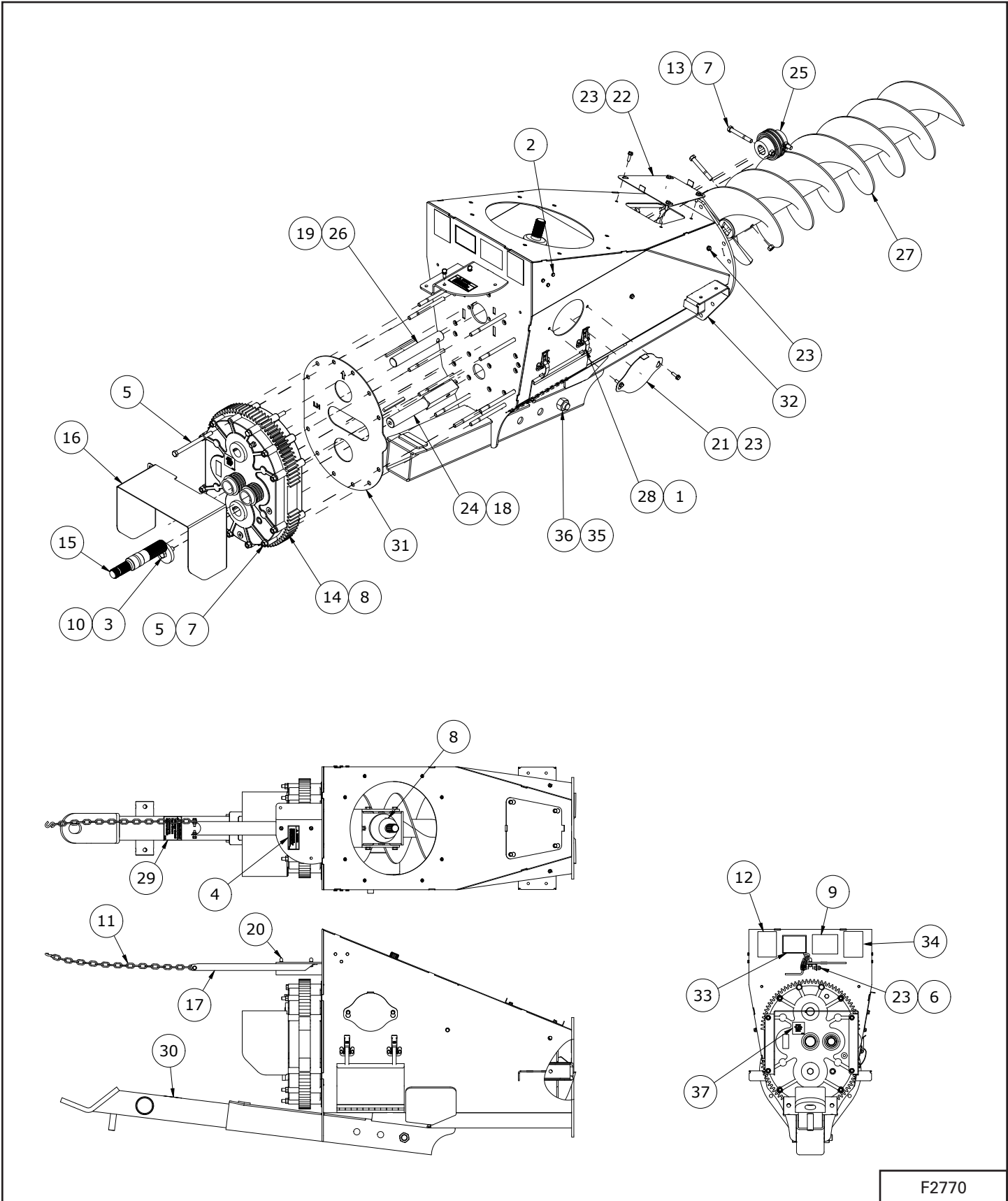

F2770

ITEM	PART NUMBER	DESCRIPTION	QTY.
1	81523	1/4" X 1/2" HEX BOLT (PL)	4
2	81525	1/4" X 3/4" HEX BOLT (PL)	6
3	84270	5/8" X 1 3/4" HEX BOLT (PL)	1
4	108431	DECAL WARNING-CHECK PTO SHAFT	1
5	811829	1/2" X 7" HEX BOLT (PL)	12
6	812362	5/16" LOCK NUT (PL)	2
7	812364	NUT-HEX-GR5-(ZT)-1/2_13	13
8	904578	GEAR OIL - SAE 75W-90, SYNTHETIC	3.25L
9	904585	DECAL-DANGER ROTATING DRIVELINE	1
10	906073L	WASHER - INPUT BOX SHFT	1
11	909703	PTO HOLDER CHAIN ASSY	1
12	909745	DECAL-DANGER ELECTROCUTION	1
13	910025	1/2" X 4" GR8 HEX BOLT (PL)	3
14	910927	GEARBOX-M1000 HELICAL	1
15	910947	M1000 SPLINE STUB SHAFT	1
16	911083	M1000 HGBOX GUARD	1
17	911111	PTO HOLDER ARM WELDT	1
18	911130	KEY 3/8"SQ X 3.94"	1
19	911163	KEY 5/16"SQ. X 140MM	1
20	911943	3/8" X 3/4" THUMB SCREW (PL)	2
21	917446	COVER-GEARBOX ACCESS	1
22	917447	COVER-TOP ACCESS	1
23	917483	BOLT FL 0.313NC X 1.00 GR5 PL	12
24	918820	BAR-M1000 SHAFT	1
25	919354	ASSY-COUPLING H5018	1
26	919359	SHAFT-M1000 GEARBOX	1
27	928649	WELDT-INPUT BOX FLTG	1
28	931901	LATCH-SLOTTED	2
29	933285	DECAL-WARNING, MAXIMUM TOWING SPEED	1
30	941137	WELDT-HITCH TUBE BS13	1
31	943813L	HELICAL GEARBOX PLATE	1
32	944735	WELDT-INPUT BOX BS13	1
33	960371	3" X 4" LABEL INPUT BOX	1
34	960569	DECAL-DANGER UPENDING	1
35	967148	1" LOCK NUT (PL)	1
36	967229	1" X 6" HEX BOLT (PL)	1
37	967388	CHECK OIL DECAL	1

INTAKE AUGER

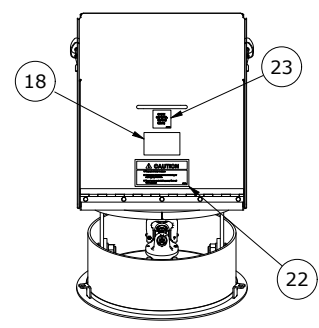
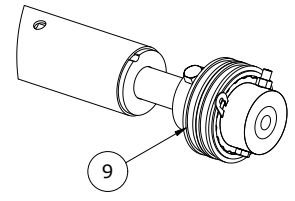
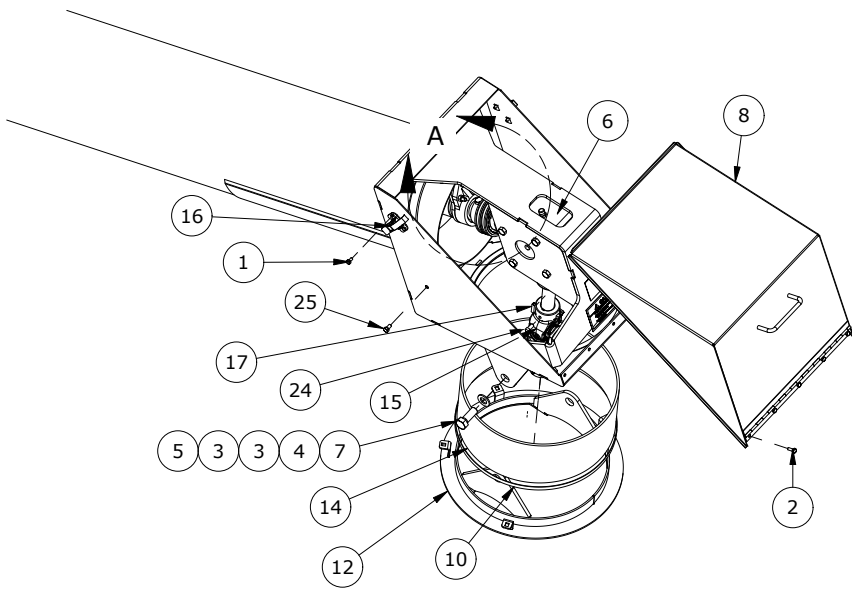

INTAKE AUGER - TOP

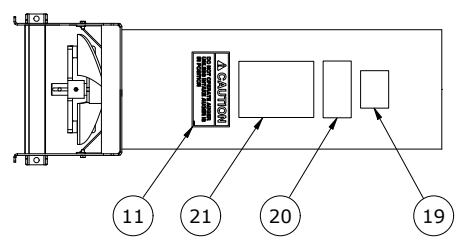
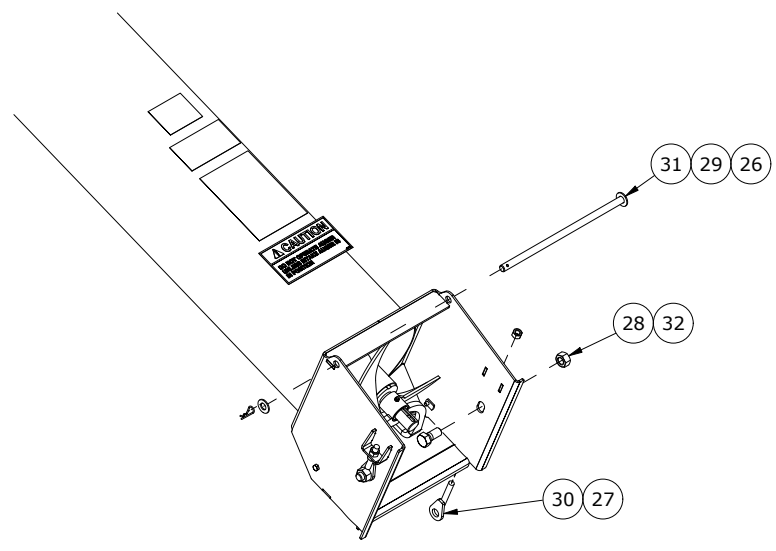

INTAKE AUGER - BOTTOM

918803

ITEM	PART NUMBER	DESCRIPTION	QTY.
1	81523	1/4" X 1/2" HEX BOLT (PL)	4
2	81525	1/4" X 3/4" HEX BOLT (PL)	5
3	84050	3/4" S.A.E. FLAT WASHER (PL)	4
4	84467	3/4" X 2" HEX BOLT (PL)	2
5	812365	3/4" LOCK NUT (PL)	2
6	904578	GEAR OIL - SAE 75W-90, SYNTHETIC	.75L
7	912503	UNDERCARRIAGE SPACER	2
8	917554	WELDT-ELBOW ACCESS DOOR BS13"	1
9	917621	CHAIN-COUPLING DOUBLE 50	1
10	917706	CLAMP HOSE-15.375 TO 17.375	2
11	917765	DECAL-INTAKE AUGER	1
12	917965	WELDT-INPUT BOX PIVOT	1
13	918818	ASSY-BS13 INTAKE AUGER	1
14	919032	COVER-INPUT BOX PIVOT	1
15	930508	DOUBLE JOINT - CAT 3, 50 DEG	1
16	931901	LATCH-SLOTTED	2
17	960180	U-JOINT & SPROCKET KEY .313"SQ. X 1.375"	1
18	960372	DECAL-IMPORTANT ALIGN YOKE	1
19	961015	DECAL-IMPORTANT RUN AUGER	1
20	961016	DECAL-DANGER KEEP HANDS	1
21	961017	DECAL-CAUTION 14 POINT	1
22	963206	CAUTION DECAL	1
23	967388	CHECK OIL DECAL	1
24	9812378	3/8" X 3/4" SQ HD SET SCREW SER	2
25	BU500397-6	HEX BOLT 5/16 X 5/8" (PL)	2
26	12780	#7 HAIR PIN CLIP	1
27	81636	1/2" HEX NUT (PL)	4
28	812365	3/4" LOCK NUT (PL)	2
29	812639	WASHER 0.625 SAE FLAT BS PL	1
30	914449	WELDT - HOPPER ADJUSTMENT	2
31	918914	WELDT-PIVOT PIN	1
32	967437	3/4" X 1 5/8" HEX BOLT (PL)	2

INTAKE AUGER FLIGHTING

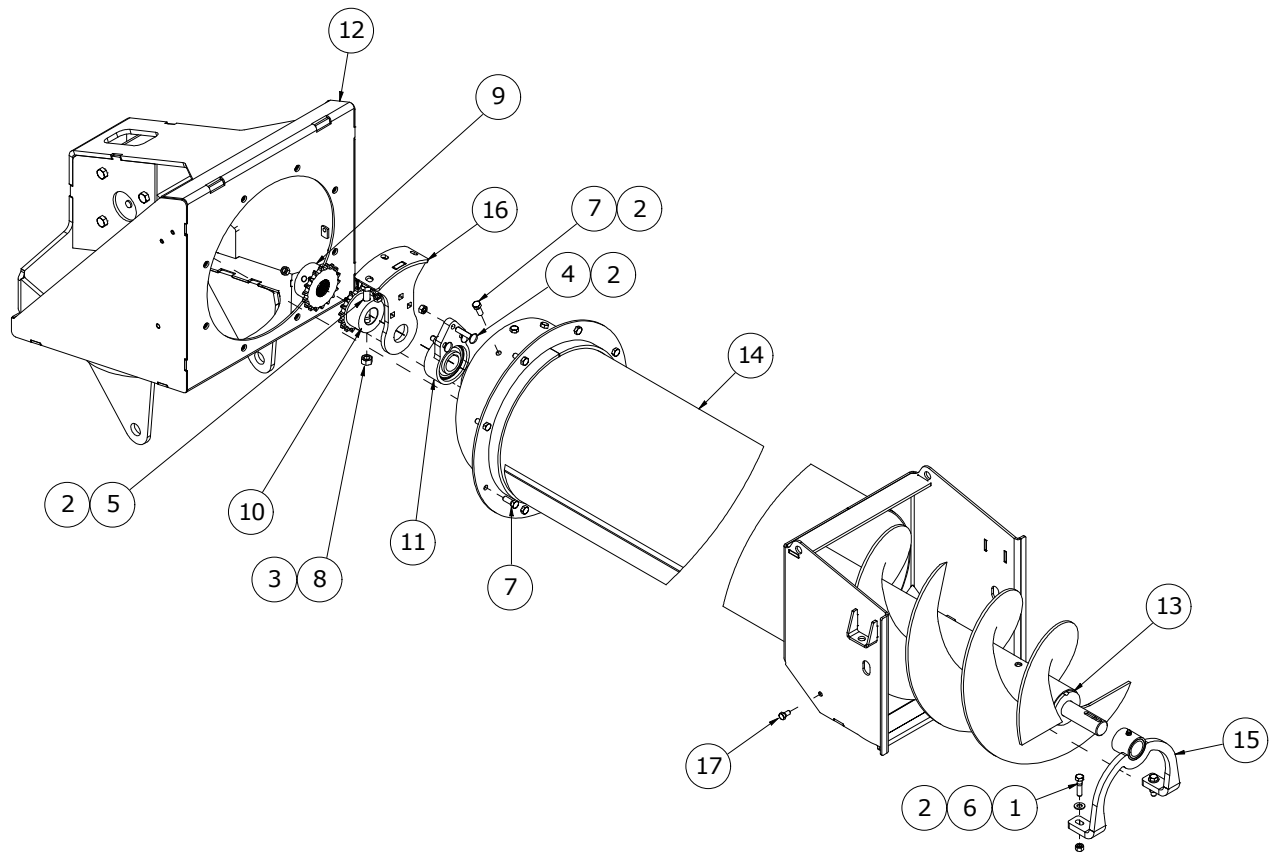

918818

ITEM	PART NUMBER	DESCRIPTION	QTY.
1	811792	3/8" X 1 1/2" HEX BOLT GR.5 (PL)	2
2	812363	3/8" LOCK NUT (PL)	9
3	812364	1/2" LOCK NUT (PL)	1
4	813517	3/8" X 1.75" CARRIAGE BOLT (PL)	3
5	81585	3/8" X 3 1/2" HEX BOLT (PL)	1
6	84039	WASHER - 3/8" SAE FLAT (PL)	2
7	86170	3/8" X 1" HEX BOLT GR.5 (PL)	11
8	910025	1/2" X 4" GR8 HEX BOLT (PL)	1
9	917634	SPROCKET-COUPPLING 50 W/SPLINE	1
10	917636	SPROCKET-COUPPLING 50 W/BORE	1
11	917712	BEARING-1.375 ID FLANGE	1
12	917785	WELDT-INPUT BOX ELBOW BS13	1
13	918755	WELDT - INTAKE FLTG BS13	1
14	918845	WELDT-INTAKE AUGERTUBE BS13	1
15	918916	WELDT - INTAKE FLTG HOLDER	1
16	918978	WELDT - HANGER BRKT	1
17	BU500397-6	HEX BOLT 5/16 X 5/8" (PL)	2

SINGLE-FLIGHTING HOPPER

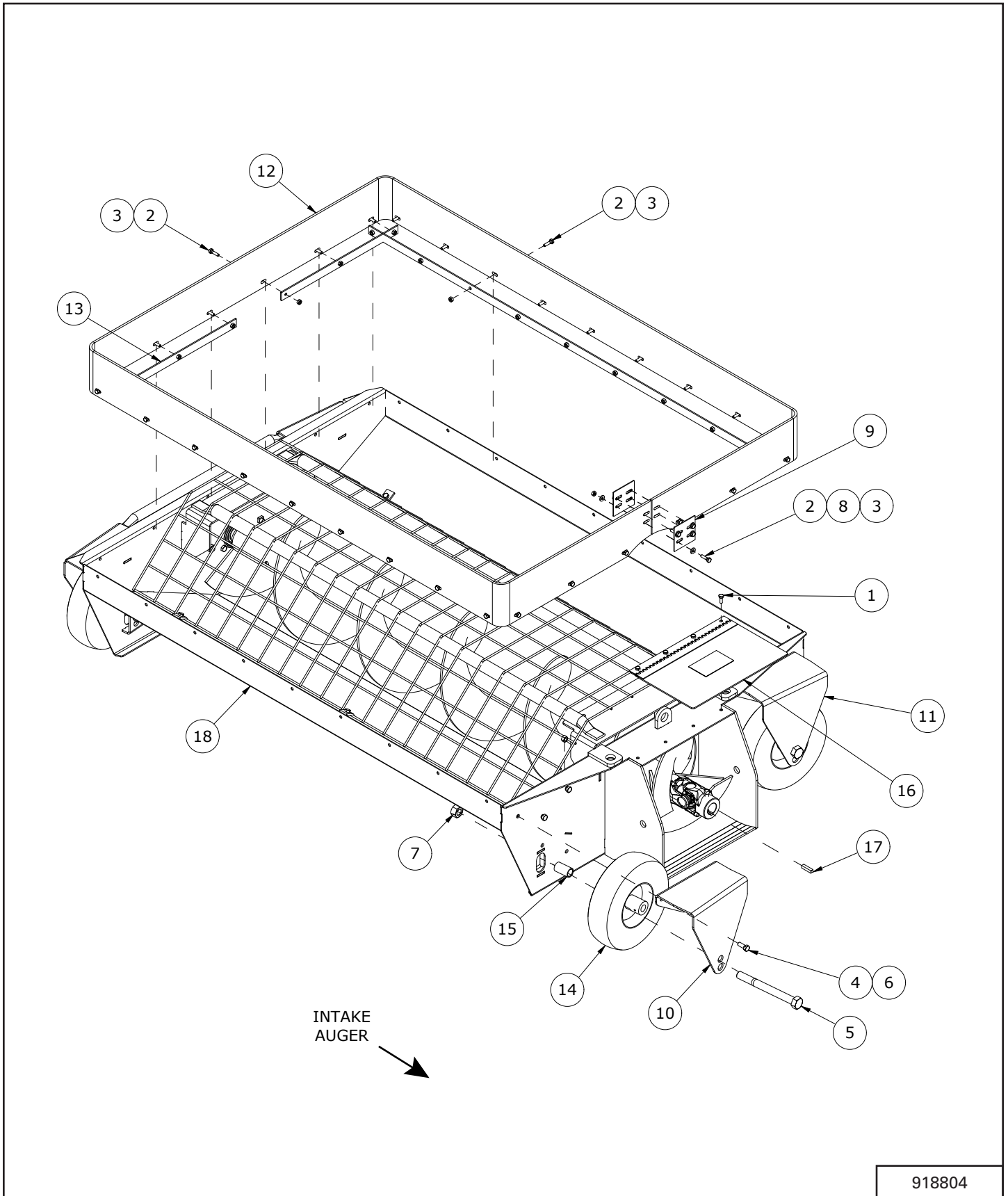

ITEM	PART NUMBER	DESCRIPTION	QTY.
1	81525	1/4" X 3/4" HEX BOLT (PL)	4
2	81527	1/4" X 1" HEX BOLT (PL)	34
3	84498	1/4" LOCK NUT (PL)	34
4	86170	3/8" X 1" HEX BOLT GR.5 (PL)	6
5	811746	3/4" X 7.5" HEX BOLT	2
6	812363	3/8" LOCK NUT (PL)	6
7	812365	3/4" LOCK NUT (PL)	2
8	812624	1/4" FLAT WASHER PL	8
9	903483L	RUBBER CONN PL 14GA X 3"SQ.	2
10	917536	BRKT-WHEEL MOUNT LH	1
11	917537	BRKT-WHEEL MOUNT RH	1
12	918911	RUBBER-HOPPER SKIRT	1
13	918912L	PLATE-RUBBER REINFORCEMENT	4
14	932052	HAND TRUCK TIRE & WHEEL ASSEMBLY ZIGZAG	2
15	943312	TUBE-WHEEL SPACER 1.000" DIA	2
16	946800	WELDT-INTAKE ACCESS W/ DECAL	1
17	960180	U-JOINT & SPROCKET KEY .313"SQ. X 1.375"	1
18	F2662	ASSY-SINGLE FLTG HOPPER (AFTER PAINT)	1

SINGLE-FLIGHTING HOPPER FLIGHTING

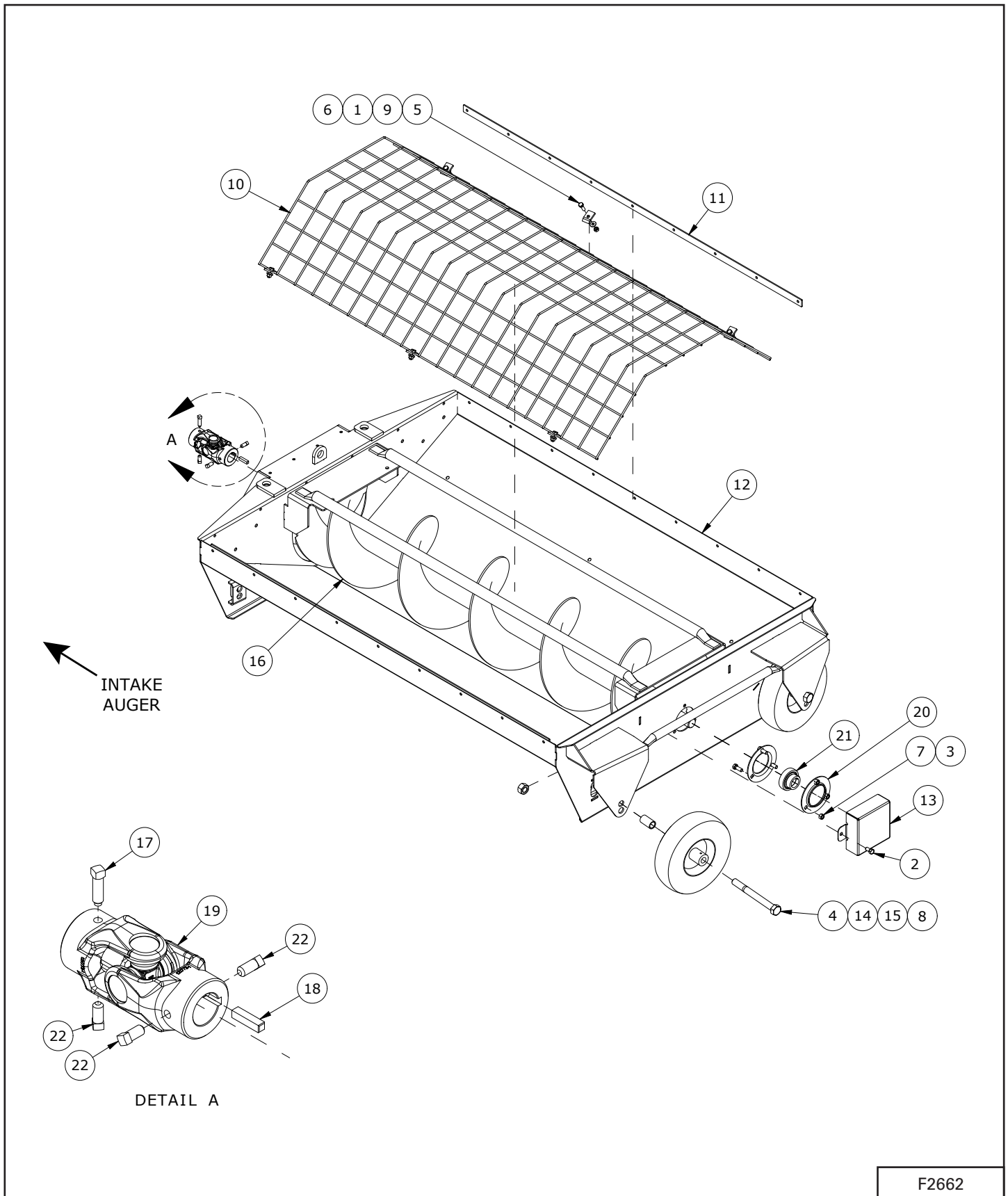

ITEM	PART NUMBER	DESCRIPTION	QTY.
1	81546	5/16" FLAT WASHER (PL)	6
2	84072	3/8" X 3/4" HEX BOLT (PL)	2
3	86170	3/8" X 1" HEX BOLT GR.5 (PL)	3
4	811746	3/4" X 7.5" HEX BOLT	2
5	812026	5/16" X 1" HEX BOLT (PL)	6
6	812362	5/16" LOCK NUT (PL)	6
7	812363	3/8" LOCK NUT (PL)	3
8	812365	3/4" LOCK NUT (PL)	2
9	910898	CAGE MOUNTING PL	6
10	911040	HOPPER FLTG GUARD	1
11	914768L	RUBBER REINFORCEMENT	2
12	918844	WELDT-BS13 SINGLE FLTG HOPPER	1
13	919470	GUARD-HOPPER BEARING	1
14	932052	HAND TRUCK TIRE & WHEEL ASSEMBLY ZIGZAG	2
15	943312	TUBE-WHEEL SPACER 1.000" DIA	2
16	943320	WELDT-FLTG SINGLE HOPPER	1
17	945764	SET SCREW - SQUARE HEAD 3/8-16 X 1-1/4	1
18	960180	U-JOINT & SPROCKET KEY .313"SQ. X 1.375"	1
19	960547	UNIVERSAL JOINT - 12E	1
20	961675	BEARING FLANGE 72MS	2
21	961676	1 1/4" BEARING AEL207-104 (RHP #1230)	1
22	9812378	3/8" X 3/4" SQ HD SET SCREW SER	3

MULTI-FLIGHTING HOPPER

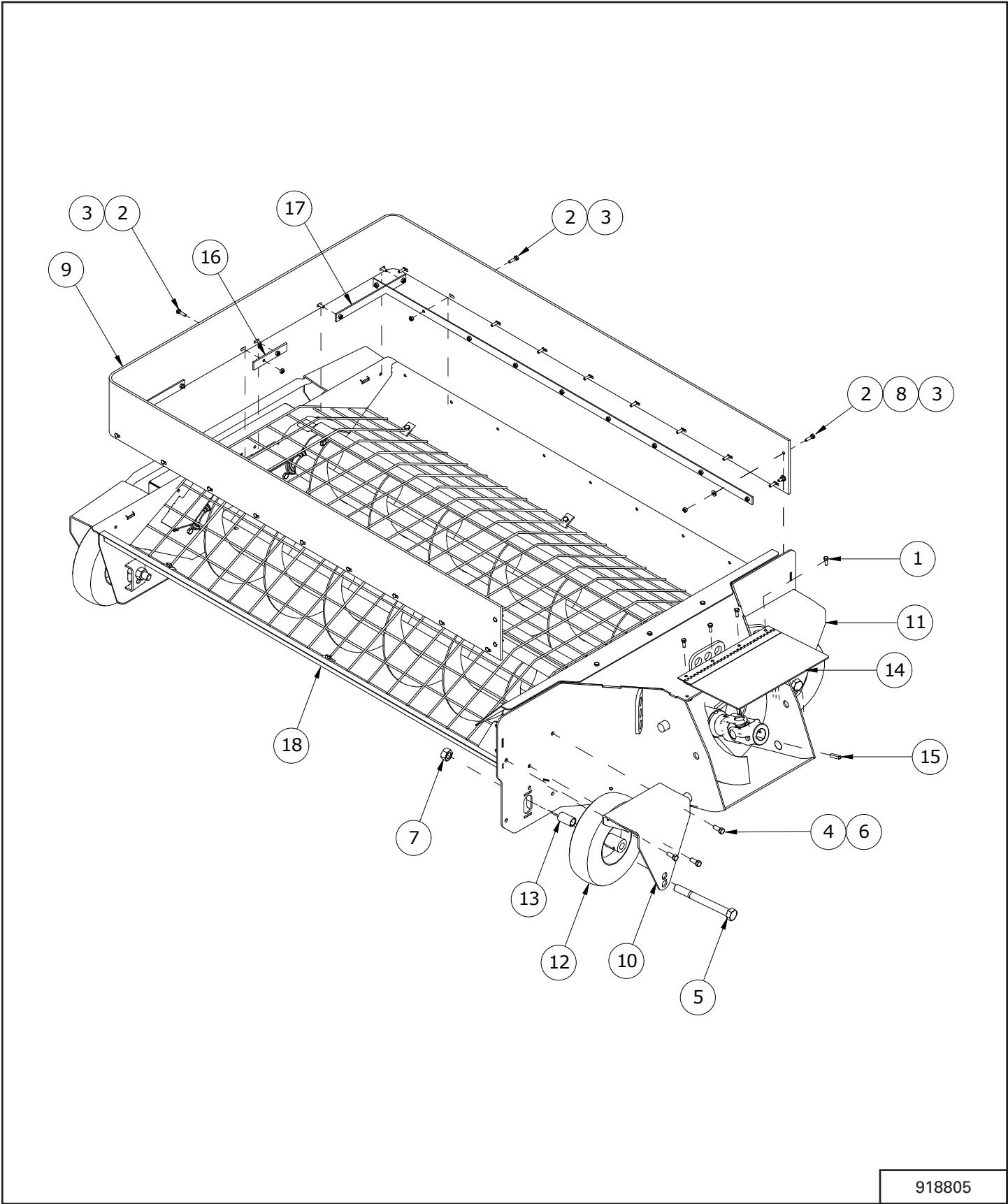

918805

ITEM	PART NUMBER	DESCRIPTION	QTY.
1	81525	1/4" X 3/4" HEX BOLT (PL)	4
2	81527	1/4" X 1" HEX BOLT (PL)	28
3	84498	1/4" LOCK NUT (PL)	28
4	86170	3/8" X 1" HEX BOLT GR.5 (PL)	6
5	811746	3/4" X 7.5" HEX BOLT	2
6	812363	3/8" LOCK NUT (PL)	6
7	812365	3/4" LOCK NUT (PL)	2
8	812624	1/4" FLAT WASHER PL	4
9	911359	RUBBER HOPPER EDGING	1
10	917536	BRKT-WHEEL MOUNT LH	1
11	917537	BRKT-WHEEL MOUNT RH	1
12	932052	HAND TRUCK TIRE & WHEEL ASSEMBLY ZIGZAG	2
13	943312	TUBE-WHEEL SPACER 1.000" DIA	2
14	946800	WELDT-INTAKE ACCESS W/ DECAL	1
15	960180	U-JOINT & SPROCKET KEY .313"SQ. X 1.375"	1
16	960834	RUBBER REINF 3/16" X 1" X 5"	1
17	960837L	PLATE - BACK RUBBER REINF	2
18	F2661	ASSY-MULTIFLTG HOPPER (AP)	1

MULTI-FLIGHTING HOPPER FLIGHTING

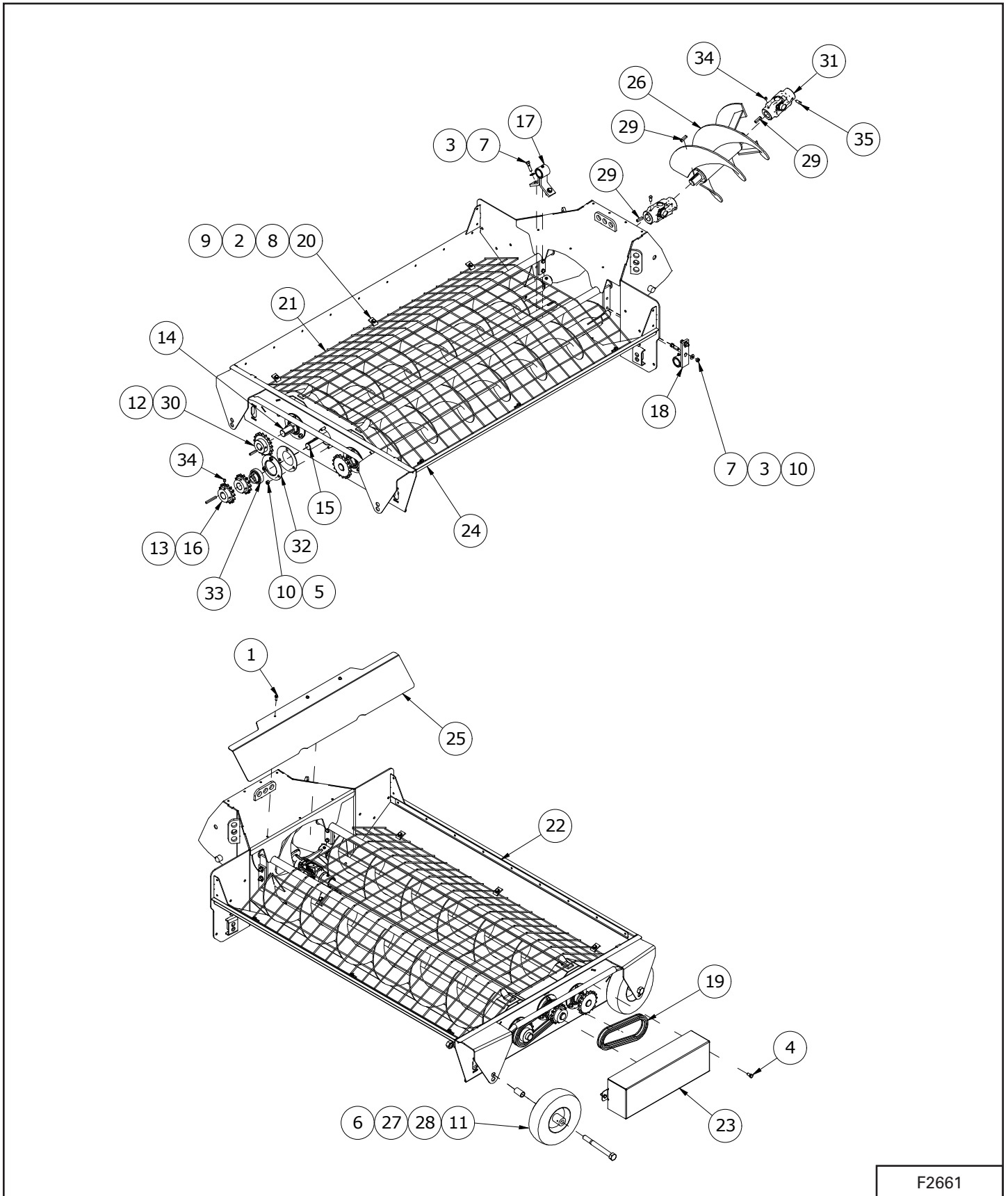

F2661

ITEM	PART NUMBER	DESCRIPTION	QTY.
1	81525	1/4" X 3/4" HEX BOLT (PL)	3
2	81546	5/16" FLAT WASHER (PL)	6
3	81570	WASHER - 3/8" STD FLAT (PL)	6
4	84072	3/8" X 3/4" HEX BOLT (PL)	2
5	86170	3/8" X 1" HEX BOLT GR.5 (PL)	9
6	811746	3/4" X 7.5" HEX BOLT	2
7	811792	3/8" X 1 1/2" HEX BOLT GR.5 (PL)	6
8	812026	5/16" X 1" HEX BOLT (PL)	6
9	812362	5/16" LOCK NUT (PL)	6
10	812363	3/8" LOCK NUT (PL)	13
11	812365	3/4" LOCK NUT (PL)	2
12	900930	1/4" X 1/4" X 1-1/2" KEY	2
13	905369	INSIDE SPRKT KEY 1/4" X 1/4" X 2 1/2"	1
14	905419	OUTSIDE FLTG WELDT (59" TUBE)	2
15	905434	CENTER FLTG ROD	1
16	905562	H60B14 SPROCKET (1 1/4" BORE)	2
17	905834	CENTER SHAFT HOLDER	1
18	905844	OUTSIDE FLIGHTING HOLDER	2
19	906558	CHAIN ASSY #60 X 35 PITCHES INCL. CONN.	2
20	910898	CAGE MOUNTING PL	6
21	910912	INTAKE FLIGHTING GUARD	1
22	914768L	RUBBER REINFORCEMENT	2
23	917607	GUARD-HOPPER CHAIN	1
24	918842	WELDT-BS13 MULTIFLTG HOPPER	1
25	918875	BRKT-HOPPER ACCESS	1
26	918924	WELDT-PIVOT FLTG	1
27	932052	HANDTRUCKTIRE & WHEEL ASSEMBLY ZIGZAG	2
28	943312	TUBE-WHEEL SPACER 1.000" DIA	2
29	960180	U-JOINT & SPROCKET KEY .313"SQ. X 1.375"	3
30	960492	H60B17 SPROCKET (1 1/4" BORE)	2
31	960547	UNIVERSAL JOINT - 12E	2
32	961675	BEARING FLANGE 72MS	6
33	961676	1 1/4" BEARING AEL207-104 (RHP #1230)	3
34	988999	3/8"0 X 3/8" SOCKET SET SCREW (BR)	10
35	9812378	3/8" X 3/4" SQ HD SET SCREW SER	6

PTO - 70, 85, 95 MODELS

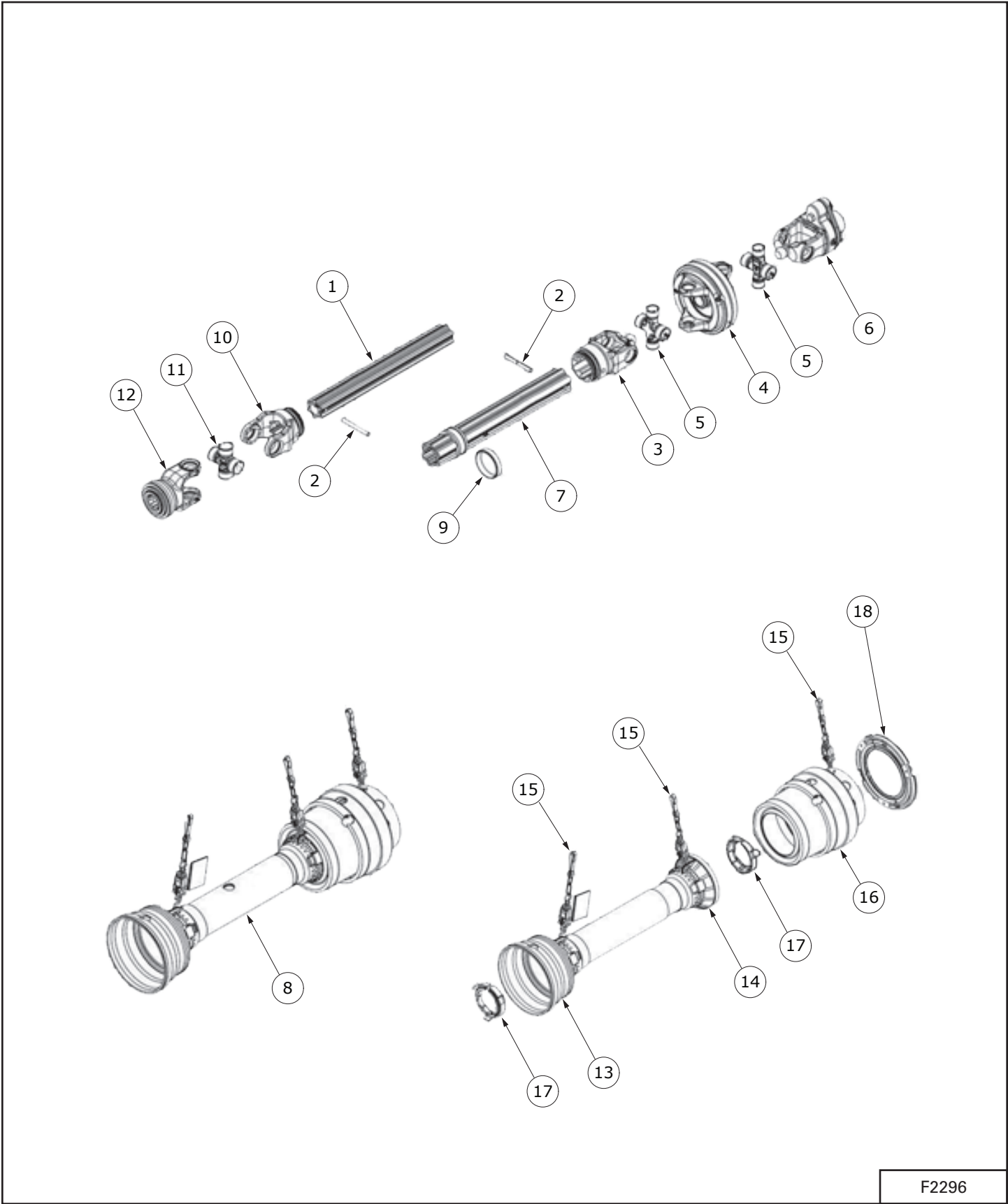

F2296

ITEM	PART NUMBER	DESCRIPTION	QTY.
1	930776	INNER RILSAN STARTUBE L = 405 WITH PIN HOLE	1
2	925360	ELASTIC PIN-ISO 8752	2
3	925369	CV WIDEANGLE INBOARDYOKE FOR INNER TUBE WITH PIN HOLE	1
4	925366	CV WIDE ANGLE 80DEG	1
5	925355	CROSS W/ GREASE NPPL ON BRG CUP	2
6	930775	SHEAR BOLT CLUTCH R48 M10 2500 NM ± 10%	1
7	930773	TUBE L=400 WITH GREASE NIPPLES AND ANTI-VIBRATING SLEEVE	1
8	930777	SHAFT SHIELD	1
9	818578	RING FOR ANTI-VIBRATION SLEEVE	1
10	925356	INBOARDYOKE FOR OUTERTUBE	1
11	925353	CROSS W/ GREASE NPPL ON BRG CUP	1
12	930772	YOKE WITH QL BALL TYPE STEEL VERSION	1
13	946981	HALF OUTER CV GUARD	1
14	946982	HALF INNER CV GUARD	1
15	925361	PRE-SET DESENGAGEMENT CHAIN	3
16	946983	CV CONE KIT	1
17	818610	RETAINER/CLIP EVOLUTION SERIES	2
18	925342	WIDEANGLE RETAINER	1
-	X4021	SHEAR BOLT KIT (M10 X 60)	-

PTO - 114 MODELS

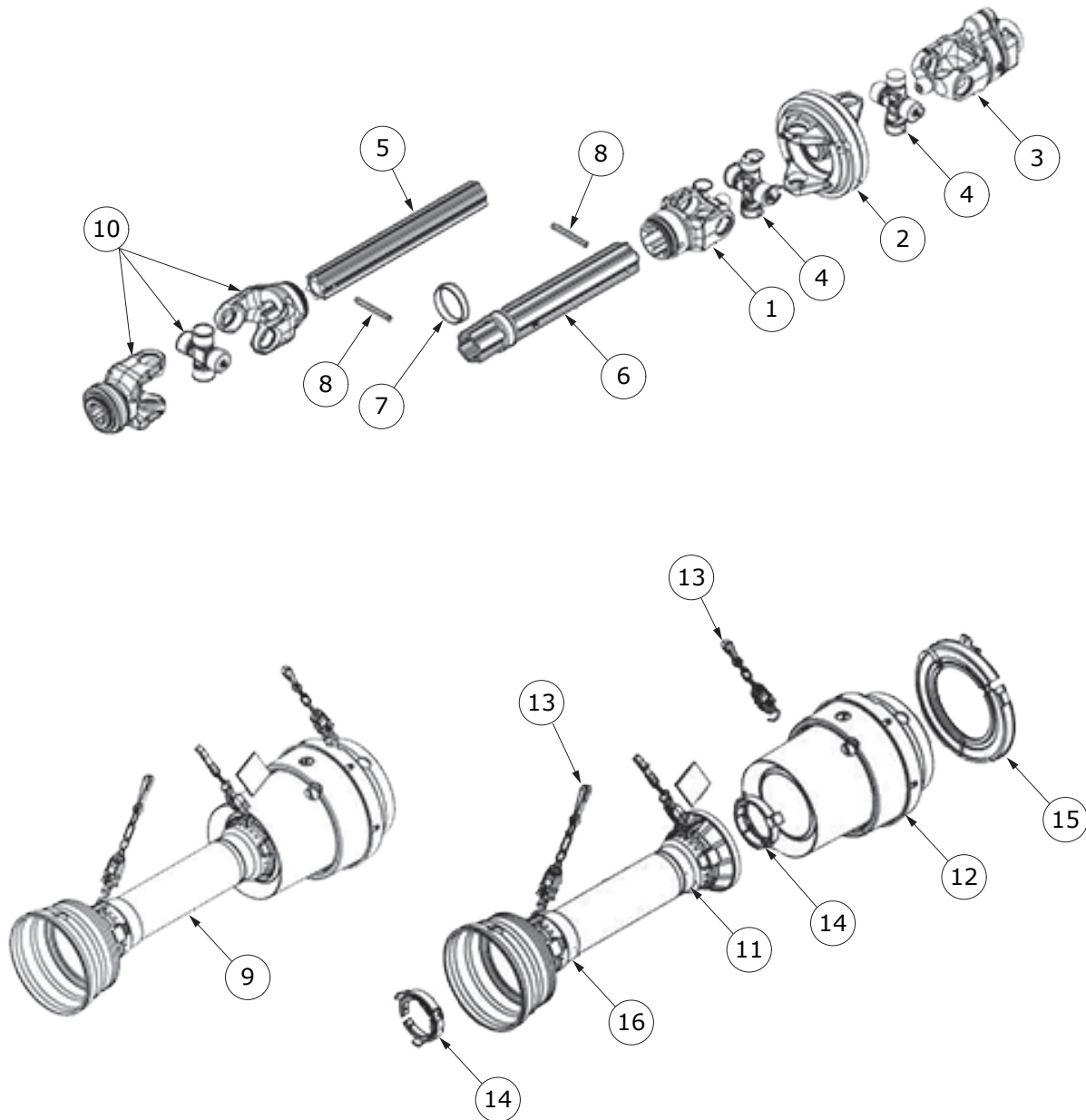

F2306

ITEM	PART NUMBER	DESCRIPTION	QTY.
1	930765	CV WIDEANGLE YOKE WELDED WITH OUTER STARTUBE HUB	1
2	930764	CV WIDEANGLE DOUBLE YOKE 80°	1
3	930786	SHEAR BOLT CLUTCH WITH PUSH PIN 2500 Nm ± 10%	1
4	925311	CROSS KIT WITH GREASE NIPPLE ON BEARING CUP	2
5	930788	RILSAN STARTUBE L = 380 WITH PIN HOLE AND CLOSING TOP	1
6	930787	STARTUBE L=370 WITH GREASE NIPPLES AND ANTI-VIBRATING SLEEVE	1
7	818578	RING FOR ANTI-VIBRATION SLEEVE	1
8	925360	ELASTIC PIN-ISO 8752	2
9	930790	SHAFT SHIELD	1
10	946932	STANDARD JOINT WITH QL COMPLETE (INCL.: 930789, 930769, 930768)	1
	930789	YOKE WITH QL BALL TYPE STEEL VERSION	1
	930769	CROSS KIT WITH GREASE NIPPLE ON BEARING CUP	1
	930768	INBOARD YOKE FOR INNER STARTUBE	1
11	946933	HALF INNER CV GUARD	1
12	946934	CV CONE KIT	1
13	925361	PRE-SET DEENGAGEMENT SYSTEM CHAIN	3
14	818610	RETAINER	2
15	925362	WIDE ANGLE RETAINER	1
16	946935	HALF OUTER CV GUARD	1
-	X4021	SHEAR BOLT KIT (M10 X 60)	-

PTO M1000 GEARBOX

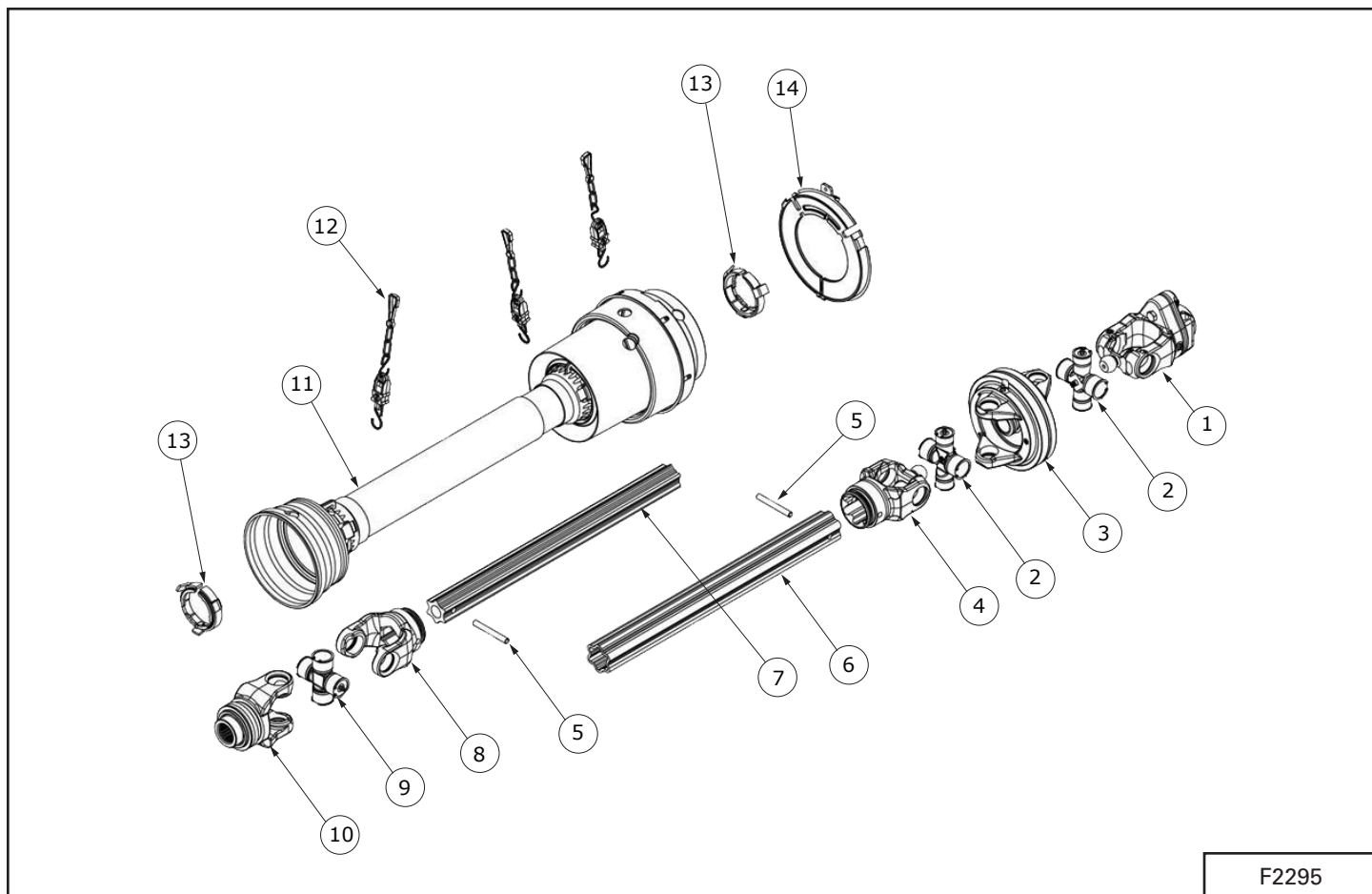

F2295

ITEM	PART NUMBER	DESCRIPTION	QTY.
1	930763	SHEAR BOLT CLUTCH 1.3/4\"-Z6 R48 M10 NM 2.500 ±10%	1
2	925311	CROSS KIT WITH GREASE NIPPLE ON BEARING CUP	2
3	930764	CV WIDEANGLE DOUBLE YOKE 80°	1
4	930765	CV WIDEANGLE YOKE WELDED WITH OUTER START TUBE HUB	1
5	925360	ELASTIC PIN - ISO 8752	2
6	930766	START TUBE L = 570 WITH CLOSING TOP	1
7	930767	RILSAN START TUBE L = 580 WITH PIN HOLE	1
8	930768	INBOARD YOKE FOR INNER START TUBE	1
9	930769	CROSS KIT WITH GREASE NIPPLE ON BEARING CUP	1
10	930770	YOKE 1.3/8\"-Z21 QL STEEL VERSION	1
11	930771	SHAFT SHIELD	1
12	925361	PRE-SET DISENGAGEMENT SYSTEM CHAIN	3
13	818610	RETAINER	2
14	925362	WIDE ANGLE RETAINER	1
-	X4021	SHEAR BOLT KIT (M10 X 60)	-

SPECIFICATIONS

DIMENSIONS.....	145
1370 MODELS.....	145
1385 / 1395 MODELS.....	146
13114 MODELS.....	147
13114 MODELS.....	148
HARDWARE TORQUE VALUES.....	149
Metric Chart.....	149
Imperial Chart.....	150
HYDRAULIC CONNECTION.....	151
O-Ring Fitting (Straight Thread).....	151
O-Ring Face Seal Connection.....	151
Flare Fitting.....	151
Port Seal (O-Ring Boss) Fitting.....	151
Tubelines And Hoses.....	151

Farm King



DIMENSIONS

1370 MODELS

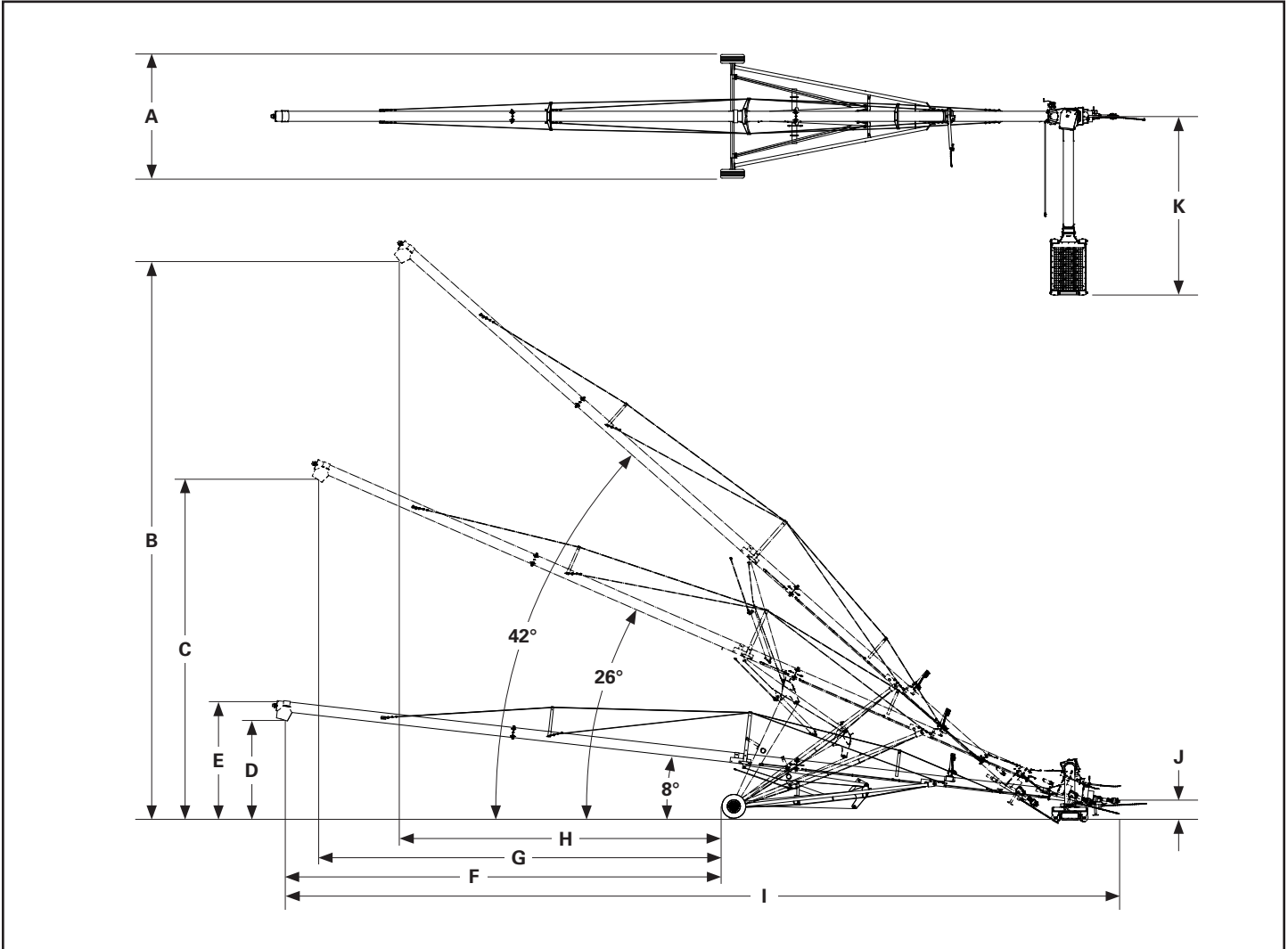

DESCRIPTION	DIMENSION
Overall Width (A)	156 in.
Discharge Spout Height @ 42° Angle (B)	593 in.
Discharge Spout Height @ 26° Angle (C)	388 in.
Discharge Spout Height @ 8° Angle (D)	129 in.
Transport Height (E)	153 in.
Discharge Spout To Wheels @ 8° Angle (F)	441 in.
Discharge Spout To Wheels @ 26° Angle (G)	415 in.
Discharge Spout To Wheels @ 42° Angle (H)	340 in.
Overall Length (I)	862 in.
Hitch Height (J)	19 in.
Input Auger / Hopper Length (K)	230 in.

1385 / 1395 MODELS

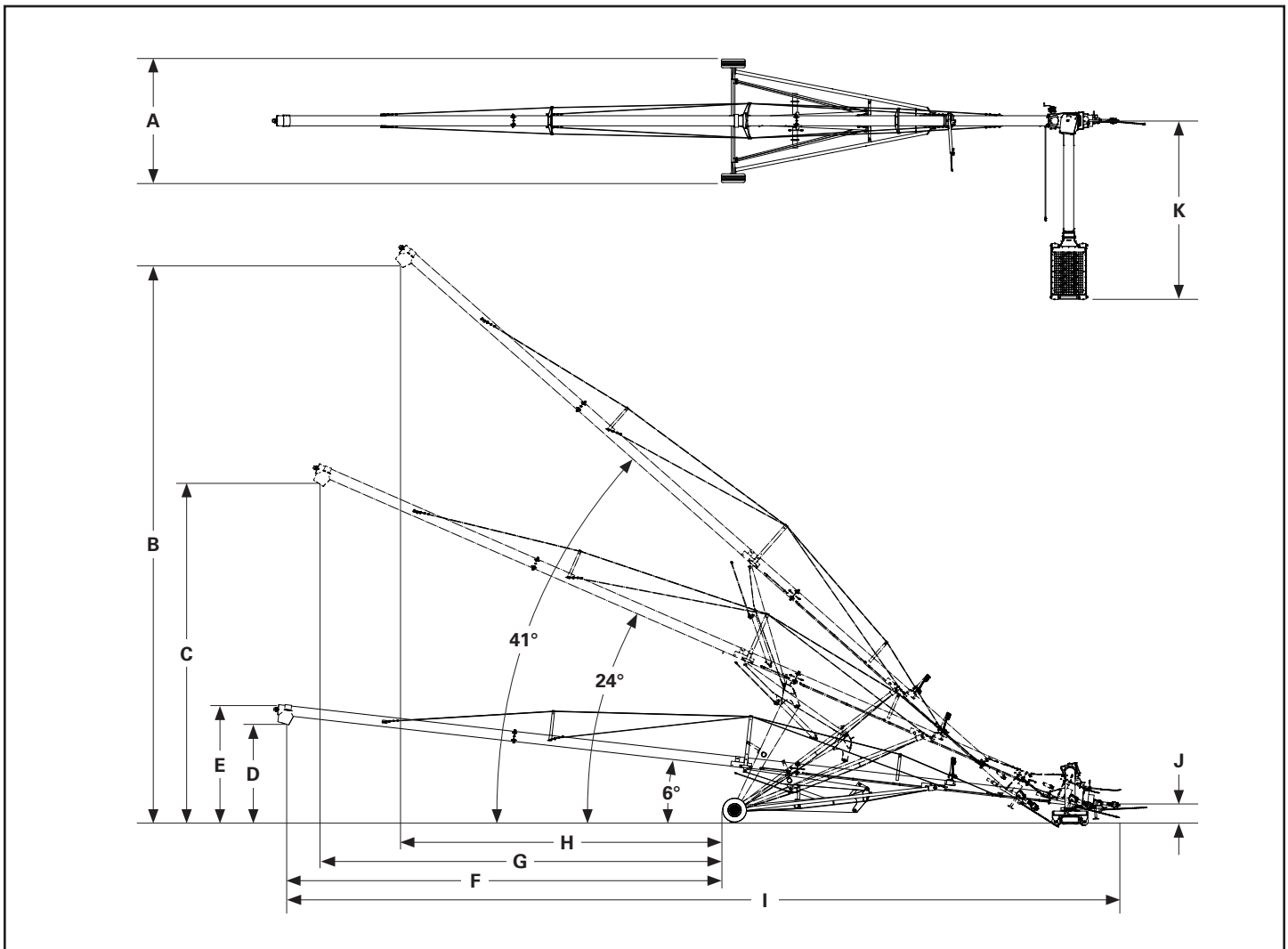

DESCRIPTION	DIMENSION	
	1385	1395
Overall Width (A)	156"	156"
Discharge Spout Height @ 41° Angle (B)	707"	787"
Discharge Spout Height @ 24° Angle (C)	428"	476"
Discharge Spout Height @ 6° Angle (D)	124"	137"
Transport Height (E)	148"	162"
Discharge Spout To Wheels @ 6° Angle (F)	553"	671"
Discharge Spout To Wheels @ 24° Angle (G)	509"	618"
Discharge Spout To Wheels @ 41° Angle (H)	406"	494"
Overall Length (I)	1045"	1164"
Hitch Height (J)	18"	18"
Input Auger / Hopper Length (K)	230"	230"

13114 MODELS

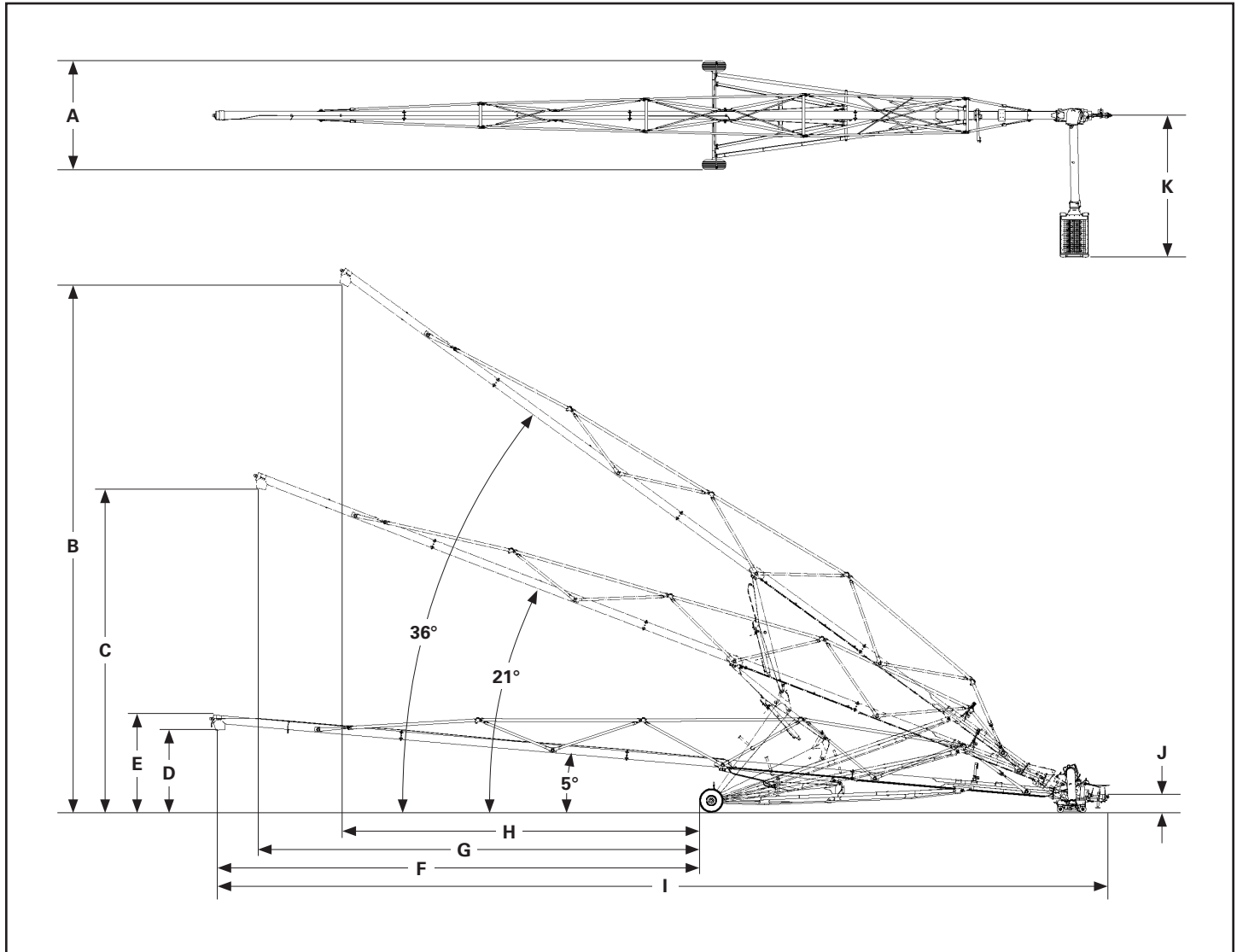

DESCRIPTION	DIMENSION
Overall Width (A)	173"
Discharge Spout Height @ 36° Angle (B)	839"
Discharge Spout Height @ 21° Angle (C)	514"
Discharge Spout Height @ 5° Angle (D)	131"
Transport Height (E)	155"
Discharge Spout To Wheels @ 5° Angle (F)	763"
Discharge Spout To Wheels @ 21° Angle (G)	698"
Discharge Spout To Wheels @ 36° Angle (H)	567"
Overall Length (I)	1409"
Hitch Height (J)	18"
Input Auger / Hopper Length (K)	230"

13114 MODELS

DESCRIPTION	1370	1385	1395	13114
Size	13" x 70'	13" x 85'	13" x 95'	13" x 114'
Tubing	All Sections 12 Gauge			
Flighting	1/4" Flighting in Swing-Away And Main Auger			
Flighting Shaft	11 Gauge, 2-3/8" Diameter			
Undercarriage	3-1/2" x 3-1/2" x 3/16" Square Tubing	4" x 4" x 1/4" Square Tubing		5" x 5" x 1/4" Square Tubing
Lift Arms	1/4" Formed Upper Tubing, 7 Gauge Lower			
Bridging	1/2" Cable			Truss Beams
Wheels And Hubs	15" With 6 Bolt Automotive Type Hubs And Bearings			16-1/2" With 8 Bolt Hubs
Swing Auger Drive	Single Internal Gearbox (PTO Driven) - Sprocket And Chain			
Hopper Dimensions	43-1/2" x 60"			
Standard Hopper Height (From Ground)*	16-3/4" (Heel End), 16-1/4" (Opposite End)			
Multi-Flighting Hopper (From Ground)*	12-3/4" (Both Ends)			
Minimum HP (W/540 RPM PTO)	80 HP	90 HP	100 HP	165 HP
Hydraulic Pressure	1200 PSI			1700 PSI
Hitch Weight	1140 lbs.	1270 lbs.	1530 lbs.	2700 lbs.
Total Weight	5175 lbs.	6381 lbs.	6683 lbs.	15500 lbs.
4168 Gearbox	75W-90 Synthetic Gear Oil			
Winch	Manual / Optional Hydraulic Winch / Optional Electric Winch			

* Not including rubber spill guard

HARDWARE TORQUE VALUES

Metric Chart

NOTE: Do not use the values listed in the charts if a different torque value or tightening procedure is specified in this manual for a specific application. Torque values listed are for general use only.

Use the following charts to determine the correct torque when checking, adjusting or replacing hardware. Torque values are listed in newton-meters (inch* or foot pounds) for normal assembly applications.

Nominal Size	Class 5.8		Class 8.8		Class 10.9		Lock nuts
	Unplated	Plated W / ZnCr	Unplated	Plated W / ZnCr	Unplated	Plated W / ZnCr	CL.8 W/ CL. 8.8 Bolt
M4	1.7 (15*)	2.2 (19*)	2.6 (23*)	3.4 (30*)	3.7 (33*)	4.8 (42*)	1.8 (16*)
M6	5.8 (51*)	7.6 (67*)	8.9 (79*)	12 (102*)	13 (115*)	17 (150*)	6.3 (56*)
M8	14 (124*)	18 (159*)	22 (195*)	28 (248*)	31 (274*)	40 (354*)	15 (133*)
M10	28 (21)	36 (27)	43 (32)	56 (41)	61 (45)	79 (58)	30 (22)
M12	49 (36)	63 (46)	75 (55)	97 (72)	107 (79)	138 (102)	53 (39)
M16	121 (89)	158 (117)	186 (137)	240 (177)	266 (196)	344 (254)	131 (97)
M20	237 (175)	307 (226)	375 (277)	485 (358)	519 (383)	671 (495)	265 (195)
M24	411 (303)	531 (392)	648 (478)	839 (619)	897 (662)	1160 (855)	458 (338)

NOTE: Torque values shown with * are inch pounds.

Identification of Hex Cap Screws and Carriage Bolts - Classes 5 and up

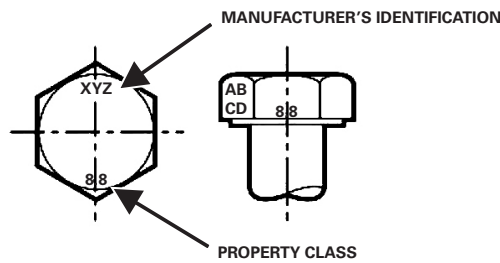

Identification of Hex Nuts and Lock Nuts - Classes 5 and up

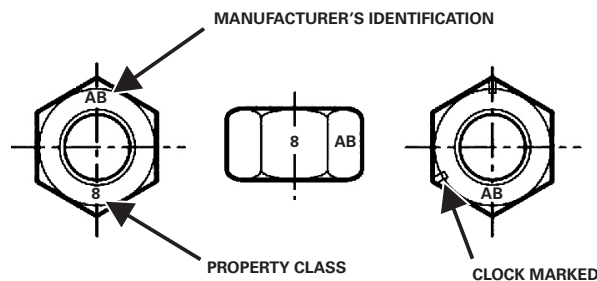

Imperial Chart

NOTE: Do not use the values listed in the charts if a different torque value or tightening procedure is specified in this manual for a specific application. Torque values listed are for general use only.

Use the following charts to determine the correct torque when checking, adjusting or replacing hardware. **Torque values are listed in newton-meters (inch* or foot pounds) for normal assembly applications.**

Nominal Size	SAE Grade 5		SAE Grade 8		LOCK NUTS			
	Unplated or Plated Silver	Plated W / ZnCr Gold"	Unplated or Plated Silver	Plated W / ZnCr Gold"	Unplated or Plated Silver	Plated W / ZnCr Gold"	Grade W / Gr. 5 Bolt	Grade W / Gr. 8 Bolt
1/4	6.2 (55*)	8.1 (72*)	9.7 (86*)	12.6 (112*)	13.6 (121*)	17.7 (157*)	6.9 (61*)	9.8 (86*)
5/16	13 (115*)	17 (149*)	20 (178*)	26 (229*)	28 (250*)	37 (324*)	14 (125*)	20 (176*)
3/8	23 (17)	30 (22)	35 (26)	46 (34)	50 (37)	65 (48)	26 (19)	35 (26)
7/16	37 (27)	47 (35)	57 (42)	73 (54)	80 (59)	104 (77)	41 (30)	57 (42)
1/2	57 (42)	73 (54)	87 (64)	113 (83)	123 (91)	159 (117)	61 (45)	88 (64)
9/16	81 (60)	104 (77)	125 (92)	163 (120)	176 (130)	229 (169)	88 (65)	125 (92)
5/8	112 (83)	145 (107)	174 (128)	224 (165)	244 (180)	316 (233)	122 (90)	172 (127)
3/4	198 (146)	256 (189)	306 (226)	397 (293)	432 (319)	560 (413)	217 (160)	306 (226)
7/8	193 (142)	248 (183)	495 (365)	641 (473)	698 (515)	904 (667)	350 (258)	494 (364)
1	289 (213)	373 (275)	742 (547)	960 (708)	1048 (773)	1356 (1000)	523 (386)	739 (545)

NOTE: Torque values shown with * are inch pounds.

Identification of Hex Cap Screws and Carriage Bolts



GRADE 2
SAE BOLT



GRADE 5
SAE BOLTS



GRADE 8
SAE BOLTS



GRADE 2
SAE NUTS



GRADE 5
SAE NUTS



GRADE 8
SAE NUTS

Identification of Hex Nuts and Lock Nuts

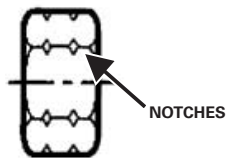

NOTCHES

GRADE IDENTIFICATION

GRADE A: NO NOTCHES

GRADE B: ONE CIRCUMFERENTIAL NOTCH

GRADE C: TWO CIRCUMFERENTIAL NOTCHES

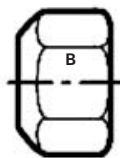

B

GRADE IDENTIFICATION

GRADE A: NO MARK

GRADE B: LETTER B

GRADE C: LETTER C

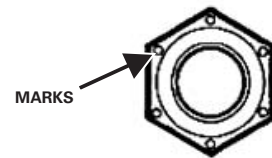

MARKS

GRADE IDENTIFICATION

GRADE A: NO MARKS

GRADE B: THREE MARKS

GRADE C: SIX MARKS

MARKS NEED NOT BE LOCATED AT CORNERS

HYDRAULIC CONNECTION

O-Ring Fitting (Straight Thread)

Lubricate the O-ring before installing the fitting. Loosen the jam nut and install the fitting. Tighten the jam nut until the washer is tight against the surface.

O-Ring Face Seal Connection

O-ring Face Seal Tightening Torque		
Tubeline O.D.	Thread Size	N•m (ft.-lbs.)
1/4"	9/16" -18	13 (18)
3/8"	11/16" -16	22 (30)
1/2"	13/16" -16	40 (54)
5/8"	1" -14	60 (81)
3/4"	1-3/16" -12	84 (114)
7/8"	1-3/16" -12	98 (133)
1"	1-7/16" -12	118 (160)
1-1/4"	1-11/16" -12	154 (209)
1-1/2"	2" -12	163 (221)

When the fitting is tightened, you can feel when the fitting is tight to eliminate leakage caused by under or over torqued fittings. Use petroleum jelly to hold the O-ring in position until the fittings are assembled.

Flare Fitting

Flare Fitting Tightening Torque		
Tubeline O.D.	Thread Size	N•m (ft.-lbs.)
1/4"	7/16" -20	13 (18)
5/16"	1/2" -20	17 (23)
3/8"	9/16" -18	22 (30)
1/2"	3/4" -16	40 (54)
5/8"	7/8" -14	60 (81)
3/4"	1-1/16" -12	84 (114)
7/8"	1-3/16" -12	98 (133)
1"	1-5/16" -12	118 (160)
1-1/4"	1-5/8" -12	154 (209)
1-1/2"	1-7/8" -12	163 (221)
2"	2-1/2" -12	252 (342)

Tighten until the nut makes contact with the seat. Use the chart to find the correct tightness needed.

Port Seal (O-Ring Boss) Fitting

Port Seal And O-ring Boss Tightening Torque		
Tubeline O.D.	Thread Size	N•m (ft.-lbs.)
1/4"	7/16" -20	13 (18)
3/8"	9/16" -18	22 (30)
1/2"	3/4" -16	40 (54)
5/8"	7/8" -14	60 (81)
3/4"	1-1/16" -12	84 (114)
7/8"	1-3/16" -12	98 (133)
1"	1-5/16" -12	118 (160)
1-1/8"	1-7/16" -12	154 (209)
1-1/4"	1-5/8" -12	163 (221)

NOTE: Port seal and nut, washer and O-ring (O-ring Boss) fittings use the same tightening torque valve chart.

If a torque wrench cannot be used, use the following method.

Tighten the nut until it just makes metal to metal contact, you can feel the resistance.

Tighten the nut with a wrench no more than one hex flat maximum.

Do not over tighten the port seal fitting.

NOTE: If a torque wrench cannot be used, use the hex flat tightening method as an approximate guideline.

NOTE: Port seal fittings are not recommended in all applications. Use O-ring boss fittings in these applications.

Tubelines And Hoses

Replace any tube lines that are bent or flattened. They will restrict flow, which will slow hydraulic action and cause heat.

Replace hoses which show signs of wear, damage or weather cracked rubber.

Always use two wrenches when loosening and tightening hose or tubeline fittings.

Farm King



WARRANTY

FARM KING BASE LIMITED WARRANTY.....	155
Repair Parts Limited Warranty.....	155
What Is Not Covered.....	155
Authorized Dealer And Labor Costs.....	155
Warranty Requirements.....	156

Farm King



FARM KING BASE LIMITED WARRANTY

Farm King provides this warranty only to original retail purchasers of its products. Farm King warrants to such purchasers that all Farm King manufactured parts and components used and serviced as provided for in the Operator's Manual shall be free from defects in materials and workmanship for a period following delivery to the original retail purchaser of two (2) years. This limited warranty applies only to those parts and components manufactured by Farm King. Parts and components manufactured by others are subject to their manufacturer's warranties, if any.

Farm King will fulfill this limited warranty by, at its option, repairing or replacing any covered part that is defective or is the result of improper workmanship, provided that the part is returned to Farm King within thirty (30) days after the Returned Material Authorization (RMA) is issued. Parts must be returned through the selling representative and the buyer must prepay transportation charges.

Farm King will not be responsible for repairs or replacements that are necessitated, in whole or part, by the use of parts not manufactured by or obtained from Farm King. Under no circumstances are component parts warranted against normal wear and tear. There is no warranty on product pump seals, product pump bearings, rubber product hoses, pressure gauges, or other components that require replacement as part of normal maintenance.

Repair Parts Limited Warranty

Farm King warrants genuine Farm King replacement parts purchased after the expiration of the Farm King Limited Warranty, and used and serviced as provided for in the Operator's Manual, to be free from defects in materials or workmanship for a period of thirty (30) days from the invoice date for the parts. Farm King will fulfill this limited warranty by, at its option, repairing or replacing any covered part that is defective or is the result of improper workmanship, provided that the part is returned to Farm King within thirty (30) days of the date that such defect or improper workmanship is, or should have been, discovered. Such parts must be shipped to the Farm King factory at the purchaser's expense.

What Is Not Covered

Under no circumstances does this limited warranty cover any components or parts that have been subject to the following: negligence; alteration or modification not approved by Farm King; misuse; improper storage; lack of reasonable and proper maintenance, service, or repair; normal wear; damage from failure to follow operating instructions; accident; and/or repairs that have been made with parts other than those manufactured, supplied, and or authorized by Farm King.

Authorized Dealer And Labor Costs

Repairs eligible for labor under this limited warranty must be made by Farm King or an authorized Farm King dealer. Farm King retains the exclusive discretion to determine whether it will pay labor costs for warranty repairs or replacements, and the amount of such costs that it will pay and the time in which the repairs will be made. If Farm King determines that it will pay labor costs for warranty work, it will do so by issuing a credit to the dealer's or distributor's account. Work done by a third party must be pre-approved by Farm King.

Warranty Requirements

To be covered by warranty, each new product must be registered with Farm King within thirty (30) days of delivery to original retail purchaser. If the customer decides to purchase replacement components before the warranty disposition of such components is determined, Farm King will bill the customer for such components and then credit the replacement invoice for those components later determined to be covered by this limited warranty. Any such replacement components that are determined not be covered by this limited warranty will be subject to the terms of the invoice and shall be paid for by the purchaser.

EXCLUSIVE EFFECT OF WARRANTY AND LIMITATION OF LIABILITY

TO THE EXTENT PERMITTED BY LAW, FARM KING DISCLAIMS ANY WARRANTIES, REPRESENTATIONS, OR PROMISES, EXPRESS OR IMPLIED, AS TO THE QUALITY, PERFORMANCE, OR FREEDOM FROM DEFECT OF THE COMPONENTS AND PARTS COVERED BY THIS WARRANTY AND NOT SPECIFICALLY PROVIDED FOR HEREIN.

TO THE EXTENT PERMITTED BY LAW, FARM KING DISCLAIMS ANY IMPLIED WARRANTIES OF MERCHANTABILITY AND FITNESS FOR A PARTICULAR PURPOSE ON ITS PRODUCTS COVERED HEREIN, AND DISCLAIMS ANY RELIANCE BY THE PURCHASER ON FARM KING'S SKILL OR JUDGMENT TO SELECT OR FURNISH GOODS FOR ANY PARTICULAR PURPOSE. THE PURCHASER'S ONLY AND EXCLUSIVE REMEDIES IN CONNECTION WITH THE BREACH OR PERFORMANCE OF ANY WARRANTY ON FARM KING'S PRODUCTS ARE THOSE SET FORTH HEREIN. IN NO EVENT SHALL FARM KING BE LIABLE FOR INCIDENTAL OR CONSEQUENTIAL DAMAGES (INCLUDING, BY WAY OF EXAMPLE ONLY AND NOT LIMITATION, LOSS OF CROPS, LOSS OF PROFITS OR REVENUE, OTHER COMMERCIAL LOSSES, INCONVENIENCE, OR COST OF REPLACEMENT OF RENTAL EQUIPMENT). IN NO EVENT SHALL FARM KING'S CONTRACT OR WARRANTY LIABILITY EXCEED THE PURCHASE PRICE OF THE PRODUCT. (Note that some states do not allow limitations on how long an implied warranty lasts or the exclusion or limitation of incidental or consequential damages, so the above limitations and exclusion may not apply to you.) This warranty gives you specific legal rights and you may also have other rights, which vary from state to state.

Farm King neither assumes nor authorizes any person or entity, including its selling representatives, to assume any other obligations or liability in connections with the sale of covered equipment, or to make any other warranties, representations, or promises, express or implied, as to the quality, performance, or freedom from defect of the components and parts covered herein. No one is authorized to alter, modify, or enlarge this limited warranty, or its exclusions, limitations and reservations.

Corrections of defects and improper workmanship in the manner, and for the applicable time periods, provided for herein shall constitute fulfillment of all responsibilities of Farm King to the purchaser, and Farm King shall not be liable in negligence, contract, or on any other basis with respect to the subject equipment.

This limited warranty is subject to any existing conditions of supply which may directly affect Farm King's ability to obtain materials or manufacturer replacement parts.

Buhler Industries Inc. reserves the right to make improvements in design or changes in specifications to its products at anytime, without incurring any obligation to owners of units previously sold.

www.farm-king.com

Farm King

301 Mountain Street South
Morden, MB R6M 1X7
E-mail: info@buhler.com
www.farm-king.com

Equipment shown is subject to change without notice.
©2024 Buhler Trading Inc. Printed in Canada TSX:BUI