

# Farm King

## ASSEMBLY INSTRUCTION MANUAL

### 10" Conventional Augers

Hopper Assembly & Caster Wheel

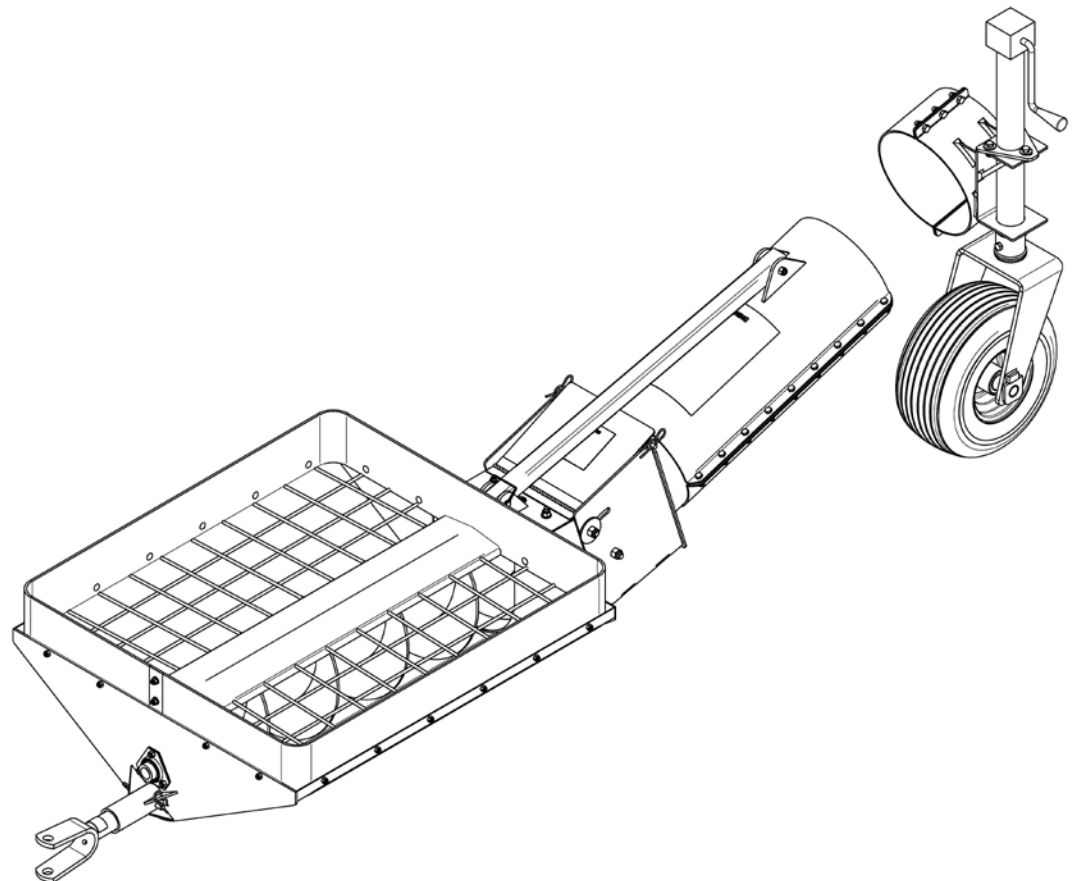



# Table of Contents

**Introduction .....4**

**Safety.....5**

- Safety .....5
- General Safety.....6
- Start-up Safety .....6
- Operation Safety .....6
- Transport Safety .....7
- Service and Maintenance Safety .....7
- Storage Safety .....7
- Safety Signs .....8
- Installation .....8

**Assembly.....9**

- Hopper Assembly.....9
- Caster Wheels.....13

**Parts .....14**

- 10" Conventional Hopper Kit (1" Diameter Auger Shaft) Drawing and Parts List ..... 14
- 10" Conventional Hopper Kit (1-1/4" Diameter Auger Shaft) Drawing and Parts List.. 16
- 10" Hopper Assembly Drawing and Parts List ..... 18
- 10" Conventional Auger Jack Assembly Drawing and Parts List.....20

**Manufacturer’s statement:** for technical reasons Buhler Industries Inc. reserves the right to modify machinery design and specifications provided herein without any preliminary notice. Information provided herein is of descriptive nature. Performance quality may depend on soil fertility, applied agricultural techniques, weather conditions and other factors.

## Introduction

---

The addition of this Farm King Conventional Hopper Assembly to your auger provides a more efficient method of conveying grain. Placing the hopper under the discharge of a grain bin permits transferring of grain to a waiting truck with minimal losses and does not require clean up of the area after use. This option will also permit you to use your conventional auger to unload trucks and wagons with minimal loss or spillage. The unique pivoting connection of the hopper to the auger allows the hopper to sit flat on the ground as the auger is adjusted for various heights of bins or trucks. This feature coupled with the constant velocity u-joint connection between the hopper and auger gives quiet vibration free operation. The additional jack/caster wheel option gives easy one-man maneuverability of the auger and allows raising of the hopper/auger assembly for lift free connecting to a towing vehicle.

Keep this manual handy for frequent reference. All new operators or owners must review this manual before using the equipment and at least annually thereafter. Contact your Farm King Dealer if you need assistance, information, or additional copies of this manual. Visit our website at [www.farm-king.com](http://www.farm-king.com) for a complete list of dealers in your area.

## Safety

---

### Safety Instructions

Remember, YOU are the key to safety. Good safety practices not only protect you, but also the people around you. Make these practices a working part of your safety program. Be certain that everyone operating this equipment is familiar with the recommended operating and maintenance procedures and follows all the safety precautions. Most accidents can be prevented. Do not risk injury or death by ignoring good safety practices.

The alert symbol is used throughout this manual. It indicates attention is required and identifies hazards. Follow the recommended precautions.



The safety alert symbol means...

**ATTENTION! BECOME ALERT! YOUR SAFETY IS INVOLVED!**



#### CAUTION

The caution symbol indicates a potentially hazardous situation that, if not avoided, may result in minor or moderate injury. It may also be used to alert against unsafe practices.



#### WARNING

The Warning Symbol indicates a potentially hazardous situation that, if not avoided, could result in death or serious injury, and includes hazards that are exposed when guards are removed. It may also be used to alert against unsafe practices.



#### DANGER

The Danger Symbol indicates an imminently hazardous situation that, if not avoided will result in death or serious injury. This signal word is to be limited to the most extreme situations, typically for machine components that, for functional purposes, cannot be guarded.

## General Safety Instructions

- Have a first-aid kit available for use and know how to use it.
- Have a fire extinguisher available, stored in a highly visible location, and know how to use it.
- Wear appropriate protective gear. This list may include but is not limited to:
  - hard hat
  - protective shoes with slip resistant soles
  - protective glasses or goggles
  - heavy gloves
  - wet weather gear
  - hearing protection
  - respirator or filter mask
- Read and understand the Operator's Manual and all safety signs before operating, servicing, adjusting, repairing, or unplugging the equipment.
- Do not attempt any unauthorized modifications to your Farm King product as this could affect function or safety, and could affect the life of the equipment.
- Inspect and clean the working area before operating.
- Keep hands, feet, clothing, and hair away from moving parts.
- Ensure bystanders are clear of the area before operating.

## Start-up Safety

- Do not let inexperienced operators or children run this equipment.
- Place all tractor and machine controls in neutral before starting.
- Do not operate inside a building unless there is adequate ventilation.
- Ensure all shields are in place and in good condition before operating.
- Stay clear of PTO shaft and machine when engaging PTO.
- The auger must be on a level surface and wheels free to move when raising or lowering. Everyone should be kept clear during these operations.

## Operation Safety

- Do not permit riders.
- Do not wear loose fitting clothing during operation.
- Empty the auger before moving to prevent upending.
- Do not allow anyone other than the operator close to the auger when in operation.
- Never stand under the auger while raising or lowering.
- Never raise the intake end of the auger above waist high, as the balance shifts forward, and the auger will tip over.
- Stay away from overhead obstructions and power lines during operation and transporting. Electrocution can occur without direct contact.

## Transport Safety

- Review Transport Safety instructions in tractor manual before moving.
- Check with local authorities regarding transport on public roads. Obey all applicable laws and regulations.
- Do not tow equipment that does not have brakes at speeds over 20 mph (32 km/h).
- Do not tow equipment that does not have brakes that, when fully loaded, has a mass (weight) over 3,300 lb (1,497 kg) and more than 1.5 times the mass (weight) of the towing unit.
- Make sure the SMV (Slow Moving Vehicle) emblem and all the lights and reflectors that are required by the local highway and transport authorities are in place, are clean, and can be seen clearly by all overtaking and oncoming traffic.
- Never have the equipment in operation during transport.
- Take extreme caution in maneuvering on or around tight corners so as not to catch the end of the auger on trees, buildings, power lines, etc.
- When moving the auger on the road, always use a red flag, or if absolutely necessary to move at night, accessory lights for adequate warning to operators of other vehicles.
- Always travel at a safe speed.
- Inflate transport tires to recommended pressure.

## Service and Maintenance Safety

- Stop engine, set brake, remove ignition key, and wait for all moving parts to stop before servicing, adjusting, repairing, or unplugging.
- Support the equipment with blocks or safety stands before working beneath it.
- Follow good shop practices including:
  - keep service area clean and dry
  - be sure electrical outlets and tools are properly grounded
  - use adequate light for the job.
- Use only tools, jacks, and hoists of sufficient capacity for the job.
- Replace and secure all shields removed during servicing before operating.
- Use heavy leather gloves to handle sharp objects.
- Check hydraulics regularly for leaks. Use cardboard to look for leaks and use hand and eye protection.
- Relieve pressure on hydraulic system before repairing or adjusting.
- Failure to follow proper procedures when mounting a tire on a wheel or rim can produce an explosion, which may result in serious injury or death.

## Storage Safety

- Store the unit in an area away from human activity.
- Do not permit children to play on or around the stored machine.
- Support the frame on stands and blocks to provide a secure base.
- When storing an auger, park it on level ground so that the bottom end will never be over its center of gravity.
- Block the wheels of the auger so that it will not move and tear the jack from its mount.

**Safety Signs**

- Keep all safety signs clean and legible and replace any that are damaged or missing.
- When original parts are replaced, any safety signs affixed to those parts should be replaced as well. Replacement safety signs are available from your local dealer.

**Installation**

- To install safety signs, ensure area is clean and dry. Decide on the exact position before you remove the backing paper. Remove the smallest portion of the split backing paper and align over the specified area. Carefully press in place.
- Slowly peel back the remaining paper and smooth the remaining portion in place. Small air pockets can be pierced with a pin and smoothed out.
- Replace safety signs immediately should they become damaged, torn or illegible. Obtain replacements from your authorized dealer using the part numbers shown.

**NOTICE**  
DO NOT TOW  
OVER 20 M.P.H.

**WARNING**



**CONTACT WITH MOVING PARTS  
MAY RESULT IN A SERIOUS  
INJURY OR DEATH!**

**KEEP SHIELD IN PLACE  
DURING OPERATION**

06023

**WARNING**

AN OPERATOR'S MANUAL IS FURNISHED WITH EACH GRAIN AUGER. ADDITIONAL OR REPLACEMENT MANUALS ARE AVAILABLE. DO NOT OPERATE THE UNIT BEFORE READING AND UNDERSTANDING THE OPERATOR'S MANUAL. UNDERSTAND THE OPERATING PROCEDURES BELOW TO AVOID PERSONAL INJURY OR DEATH.

Intentional or accidental contact with moving parts may result in a SERIOUS INJURY OR DEATH. Observe the following operating procedures:

▲ KEEP ALL SAFETY DEVICES IN PLACE! ▲ DO NOT ADJUST, SERVICE, LUBRICATE, CLEAN, UNCLOG OR MOVE THE MECHANISM UNTIL ALL POWER IS SHUT OFF! ▲ KEEP HANDS, FEET AND CLOTHING AWAY FROM MOVING PARTS WHILE IN OPERATION! ▲ KEEP OFF THE EQUIPMENT AT ALL TIMES! ▲ MAKE CERTAIN THAT EVERYONE IS CLEAR OF THE EQUIPMENT BEFORE APPLYING POWER! ▲ KEEP CHILDREN, VISITORS AND ALL UNTRAINED PERSONNEL AWAY FROM MACHINE WHILE IN OPERATION!

Care must be used when moving or transporting the auger. Accidental tipping or upending of an auger can occur and may cause SERIOUS INJURY OR DEATH to the operator or bystanders.

▲ NEVER MOVE THE AUGER MANUALLY! ▲ BE SURE AUGER IS EMPTY BEFORE ATTEMPTING TO MOVE! ▲ NEVER PUSH ON THE UNDERCARRIAGE OF THE AUGER! ▲ TOW THE AUGER AT SLOW SPEED AND IN THE DOWN POSITION! ▲ ALWAYS TEST THE INTAKE END OF THE AUGER FOR DOWNWARD WEIGHT WHEN ATTACHING OR RELEASING! ▲ NEVER RAISE THE HITCHPOINT HIGHER THAN THE VEHICLE'S TOW BAR.

An auger can collapse and fall on the operator or bystanders causing a SERIOUS INJURY OR DEATH. Always support the discharge end when the following conditions occur:

▲ WHILE UNIT IS IN OPERATION! ▲ WHEN DISMOUNTING THE UNDERCARRIAGE!

The accidental tipping or upending of an auger may cause SERIOUS INJURY OR DEATH to the operator or bystanders. When the grain flow is shut off to the auger an overbalance situation can occur, suddenly raising the intake of the auger. Adequate anchorage of the intake end or support from the bin is required at all times, especially in the following conditions:

▲ WHILE UNIT IS IN OPERATION! ▲ WHEN MOVING THE AUGER! ▲ WHEN RAISING OR LOWERING THE AUGER!

▲ Maximum elevation is determined by interference between track car and auger structure. The operator MUST STOP RAISING the auger BEFORE track car reaches the end of the track. Continued lift will cause failure of the winch, lift cable or auger supports, causing auger to collapse, resulting in SERIOUS INJURY OR DEATH!

Contact with overhead wires may cause ELECTROCUTION of the operator or bystanders. Contact with overhead obstructions can cause collapse or tipping of the auger or may cause the overhead obstruction to fall. In both cases the operator or bystander can be SERIOUSLY INJURED OR KILLED! Observe the following: ▲ TOW THE AUGER AT SLOW SPEED AND IN THE DOWN POSITION! ▲ RAISE OR LOWER THE AUGER SLOWLY!

Electrical malfunction can cause ELECTROCUTION of the operator or bystanders. Observe the following rules:

▲ DISCONNECT POWER AND ELECTRICAL DRIVEN UNITS BEFORE RESETTING MOTOR OVERLOADS!  
▲ DO NOT OPERATE ELECTRIC MOTOR EQUIPPED UNITS UNTIL UNIT IS PROPERLY GROUNDED!

Contact with rotating flighting will cause SERIOUS INJURY OR DEATH! ▲ DO NOT STAND ON INTAKE CAGE!  
▲ KEEP HANDS, FEET AND CLOTHING AWAY FROM THE INTAKE AND DISCHARGE FLIGHTING!

06010



## Assembly Instructions

---

### Hopper Assembly

1. Block auger wheels. Support auger so that intake screen can be removed.
2. Remove intake screen.

(For C1036 augers, proceed to 3b)

3. **a)** If the serial number on the C1034 auger is prior to C1034D12000001, C1034TE12000001, or C1034E12000006, the shaft on the end of the auger will have to be cut off.

Cut the shaft so there is 2" (51 mm) remaining. Smooth and chamfer the end of the shaft to ease installation of the U-joint on the hopper assembly. Continue to step 4.

Auger ready for installation of hopper.

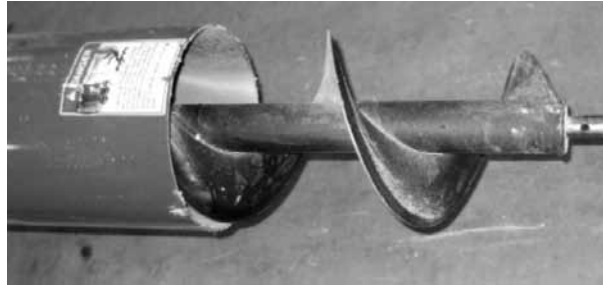

**b)** The shaft on the end of the 1036 auger will have to be cut off.

Cut the shaft so there is 2" (51 mm) remaining. Smooth and chamfer the end of the shaft to ease installation of the U-joint on the hopper assembly

**c)** Grind off the small rectangular bar at the end of the auger tube (see illustration). This will allow the half clamps to be installed properly.



- Slide two clamp halves onto auger tube.



- Slide hopper assembly onto auger.

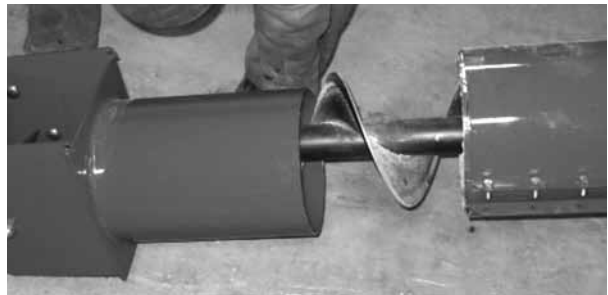

- As the hopper is being slid over the auger, be sure to align hole in U-joint with hole in auger shaft (if present). On augers without a hole in the shaft, slide U-joint on shaft and use hole in U-joint as a pilot hole to drill shaft.

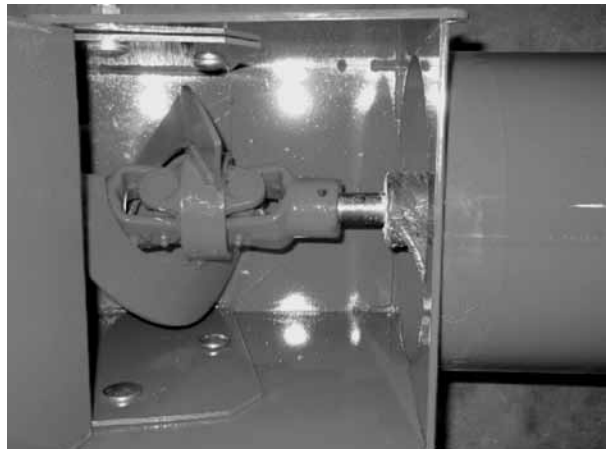

7. Insert 5/16" x 2-1/2" (8 x 64 mm) bolt into U-joint and shaft and secure with 5/16" (8 mm) locknut.



8. Slide clamp halves down to hopper and install the 3/8" x 1" (10 x 25 mm) bolts with flat washers and lock nuts. Adjust hopper to set flat (square) with the ground and tighten clamp bolts.



9. Install rubber hopper extension using the 1/4" x 1/2" (6 x 13 mm) carriage bolts provided.



10. Before transport of auger, bolt support bar in between tabs on upper half clamp using  $\frac{3}{8}$ " x 2-1/2" (10 x 64 mm) bolt with lock nut. Use snap pin provided to secure the support bar to the hopper. Adjust height of hopper as needed to ensure pin fits correctly.



## Caster Wheels

1. For installation of the caster wheel, check to see that the jack is fully retracted. Place the jack assembly on the right side of the auger tube. The jack assembly will mount below the gearbox on the 1034 PTO and electric drive augers. On other augers, place that jack in the position that best suits your needs. Once the location of the jack has been determined, place the loose clamp on the opposite side of the tube of the jack. Install the 3/8" x 1-1/2" (10 x 38 mm) bolts with lock washers and nuts. Loosely bolt the jack mount and loose clamp together. Before final tightening of the bolts in the clamps, check to make sure the jack is perpendicular to the ground. If the jack is angled, it will not caster correctly. Once it is verified that the jack is in the correct position and perpendicular to the ground, firmly tighten the bolts in the clamps.



# Parts

## 10" Conventional Hopper Kit (1" Diameter Auger Shaft)

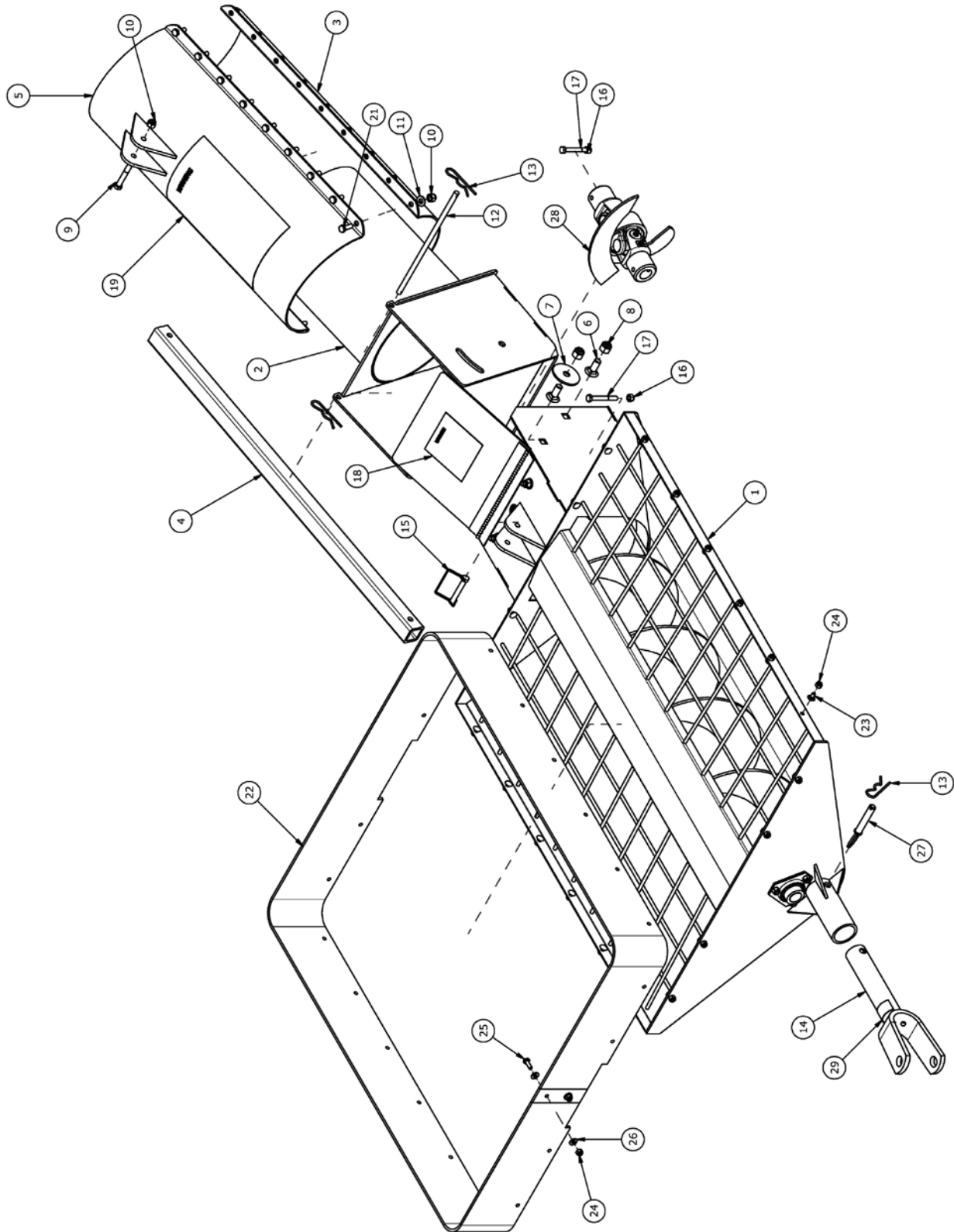

| Item | Part Number    | Description                             | Quantity |
|------|----------------|---|----------|
| 1    | SZ000628       | 10" Hopper Assembly                     | 1        |
| 2    | SZ000632       | Hopper Box Weldment                     | 1        |
| 3    | SZ992031024000 | 10" Tube Splice - 24"                   | 1        |
| 4    | SZ000635       | Transport Lock Tube                     | 1        |
| 5    | SZ000634       | Transport Lock Weldment                 | 1        |
| 6    | SZ126012       | Bolt Crg 1/2-13 UNC 1-1/4 Short Neck    | 4        |
| 7    | SZ9941718      | Washer Flat, 0.53, 2.25 10Ga Galvanized | 2        |
| 8    | SZ125032       | Nut Lock 1/2-13 UNC Nylock              | 4        |
| 9    | SZ126072       | Bolt HHCS 3/8-16 UNC 2-1/2 G5           | 1        |
| 10   | SZ125030       | Nut Lock 3/8-16 UNC Nylock              | 19       |
| 11   | SZ127002       | Washer Flat 3/8                         | 18       |
| 12   | SZ9901708      | 10" Hopper Access Door Pin              | 1        |
| 13   | SZ128018       | Pin Hair 1/8                            | 3        |
| 14   | SZ000639       | Conventional Hopper Hitch               | 1        |
| 15   | SZ000647       | 3/8" Snap Pin, 2-3/4"                   | 1        |
| 16   | SZ125035       | Nut Lock 5/16-18 UNC Nylock             | 2        |
| 17   | SZ126055       | Bolt HHCS 5/16-18 UNC 2-1/2 G5          | 2        |
| 18   | SZ06023        | Decal, Warning, Keep Shield             | 1        |
| 19   | SZ06010        | Decal, Warning                          | 1        |
| 20   | SZ06057        | Decal, Grease Gun Silhouette            | 1        |
| 21   | SZ126065       | Bolt HHCS 3/8-16 UNC 1" G5              | 18       |
| 22   | SZ000638       | 10" Conventional Hopper Rubber Belting  | 1        |
| 23   | SZ126003       | Bolt, Carriage 1/4-20 UNC 1/2           | 20       |
| 24   | SZ125028       | Nut Lock 1/4-20 UNC Nylock              | 22       |
| 25   | SZ126029       | Bolt HHCS 1/4-20 UNC 3/4 G5             | 2        |
| 26   | SZ127000       | 1/4 Flat Washer                         | 4        |
| 27   | SZ500111       | 1/2" x 2-3/4" Wheel Spindle Pin         | 1        |
| 28   | SZ9699415      | Hopper Joint Flighting w/ CV            | 1        |
| 29   | SZ06528        | Decal, Notice, Do Not Tow Over 20 mph   | 1        |

10" Conventional Hopper Kit (1-1/4" Diameter Auger Shaft)

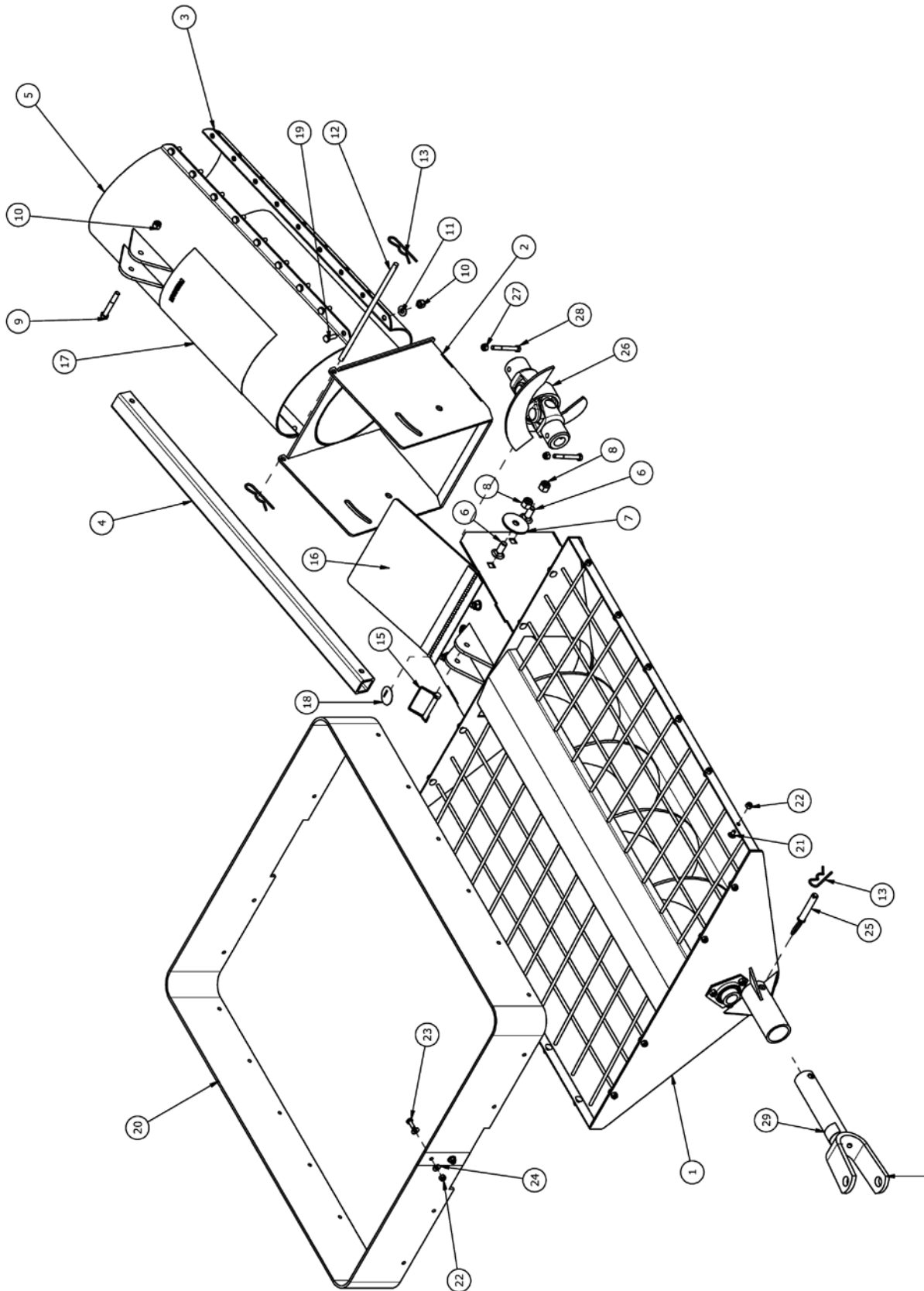



| Item | Part Number    | Description                             | Quantity |
|------|----------------|---|----------|
| 1    | SZ000628       | 10" Hopper Assembly                     | 1        |
| 2    | SZ000664       | 10" Hopper Box Weldment, FK             | 1        |
| 3    | SZ992031024000 | 10" Tube Splice - 24"                   | 1        |
| 4    | SZ000635       | Transport Lock Tube                     | 1        |
| 5    | SZ000634       | Transport Lock Weldment                 | 1        |
| 6    | SZ126012       | Bolt Crg 1/2-13 UNC 1-1/4 Short Neck    | 4        |
| 7    | SZ9941718      | Washer Flat, 0.53, 2.25 10Ga Galvanized | 2        |
| 8    | SZ125032       | Nut Lock 1/2-13 UNC Nylock              | 4        |
| 9    | SZ126072       | Bolt HHCS 3/8-16 UNC 2-1/2 G5           | 1        |
| 10   | SZ125030       | Nut Lock 3/8-16 UNC Nylock              | 19       |
| 11   | SZ127002       | Washer Flat 3/8                         | 18       |
| 12   | SZ9901708      | 10" Hopper Access Door Pin              | 1        |
| 13   | SZ128018       | Pin Hair 1/8                            | 3        |
| 14   | SZ000639       | Conventional Hopper Hitch               | 1        |
| 15   | SZ000647       | 3/8" Snap Pin, 2-3/4"                   | 1        |
| 16   | SZ06023        | Decal, Warning, Keep Shield             | 1        |
| 17   | SZ06010        | Decal, Warning                          | 1        |
| 18   | SZ06057        | Decal, Grease Gun Silhouette            | 1        |
| 19   | SZ126065       | Bolt HHCS 3/8-16 UNC 1" G5              | 18       |
| 20   | SZ000638       | 10" Conventional Hopper Rubber Belting  | 1        |
| 21   | SZ126003       | Bolt, Carriage 1/4-20 UNC 1/2           | 20       |
| 22   | SZ125028       | Nut Lock 1/4-20 UNC Nylock              | 22       |
| 23   | SZ126029       | Blt HHCS 1/4-20 UNC 3/4 G5              | 2        |
| 24   | SZ127000       | 1/4 Flat Washer                         | 4        |
| 25   | SZ500111       | 1/2" x 2-3/4" Wheel Spindle Pin         | 1        |
| 26   | SZ000678       | CV Joint (SZ000677) w/ Flight           | 1        |
| 27   | SZ125035       | Nut Lock 5/16-18 UNC Nylock             | 2        |
| 28   | SZ126055       | Blt HHCS 5/16-18 UNC 2-1/2 G5           | 2        |
| 29   | SZ06528        | Decal, Notice, Do Not Tow Over 20 mph   | 1        |

10" Hopper Assembly

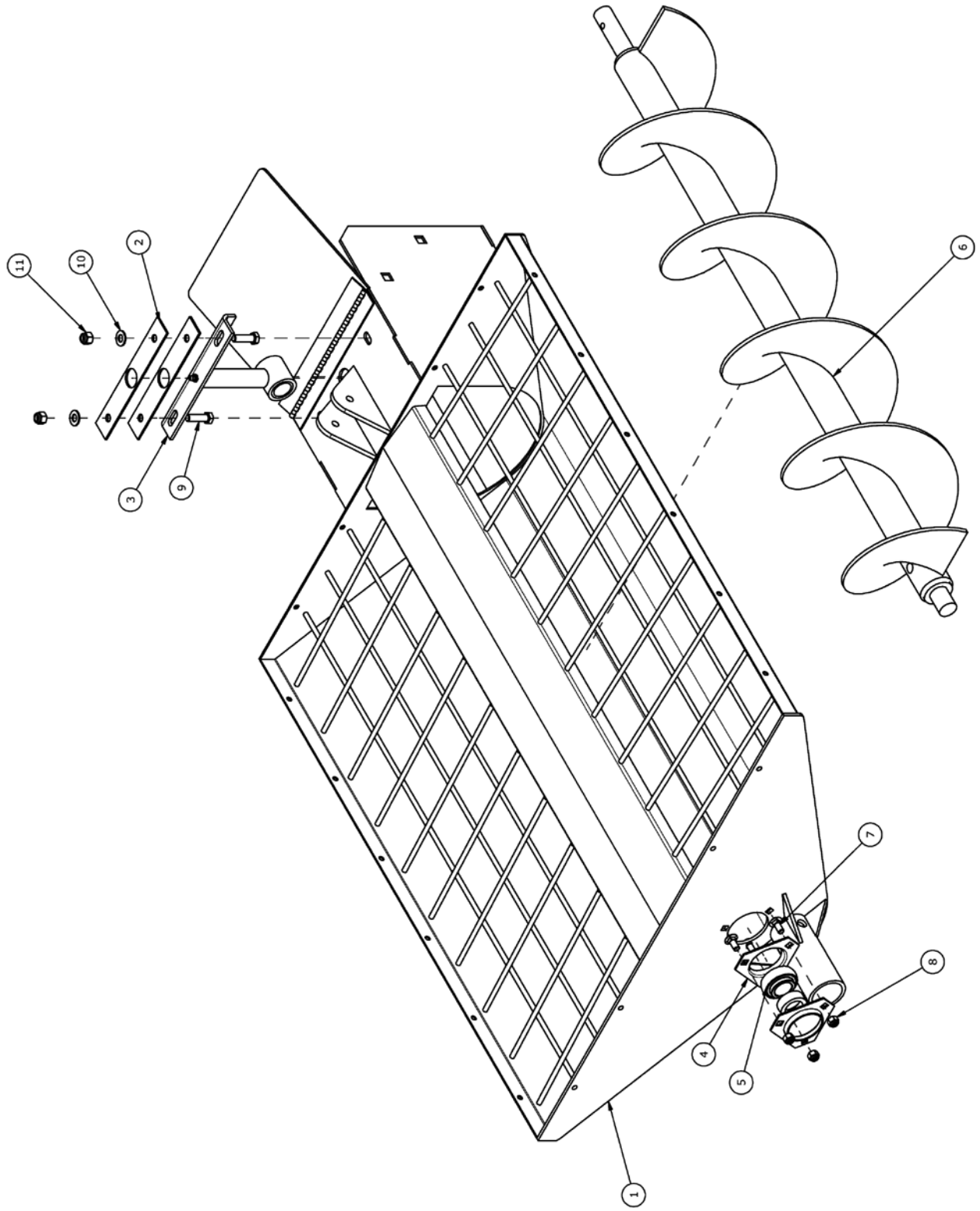

| <b>Item</b> | <b>Part Number</b> | <b>Description</b>                | <b>Quantity</b> |
|-------------|--------------------|-----------------------------------|-----------------|
| 1           | SZ000618           | Hopper Weldment                   | 1               |
| 2           | SZ9901752          | Hopper Hanger Bearing Shim        | 2               |
| 3           | SZ9901750          | Weldment Bearing Hanger Hopper    | 1               |
| 4           | SZ65052MSCI000     | Flange, Bearing 52 mm 3 Bolt      | 2               |
| 5           | SZ2017043          | Bearing, 1" w/ Loose Lock Collar  | 1               |
| 6           | SZ000629           | 10" Conventional Hopper Flighting | 1               |
| 7           | SZ126006           | Bolt Carriage 5/16-18 UNC 3/4     | 3               |
| 8           | SZ125035           | Nut Lock 5/16-18 UNC Nylock       | 3               |
| 9           | SZ126158           | Bolt HHCS 3/8-16 UNC 1-1/4 G5     | 2               |
| 10          | SZ127002           | Washer Flat 3/8                   | 2               |
| 11          | SZ125030           | Nut Lock 3/8-16 UNC Nylock        | 2               |

10" Conventional Auger Jack Assembly

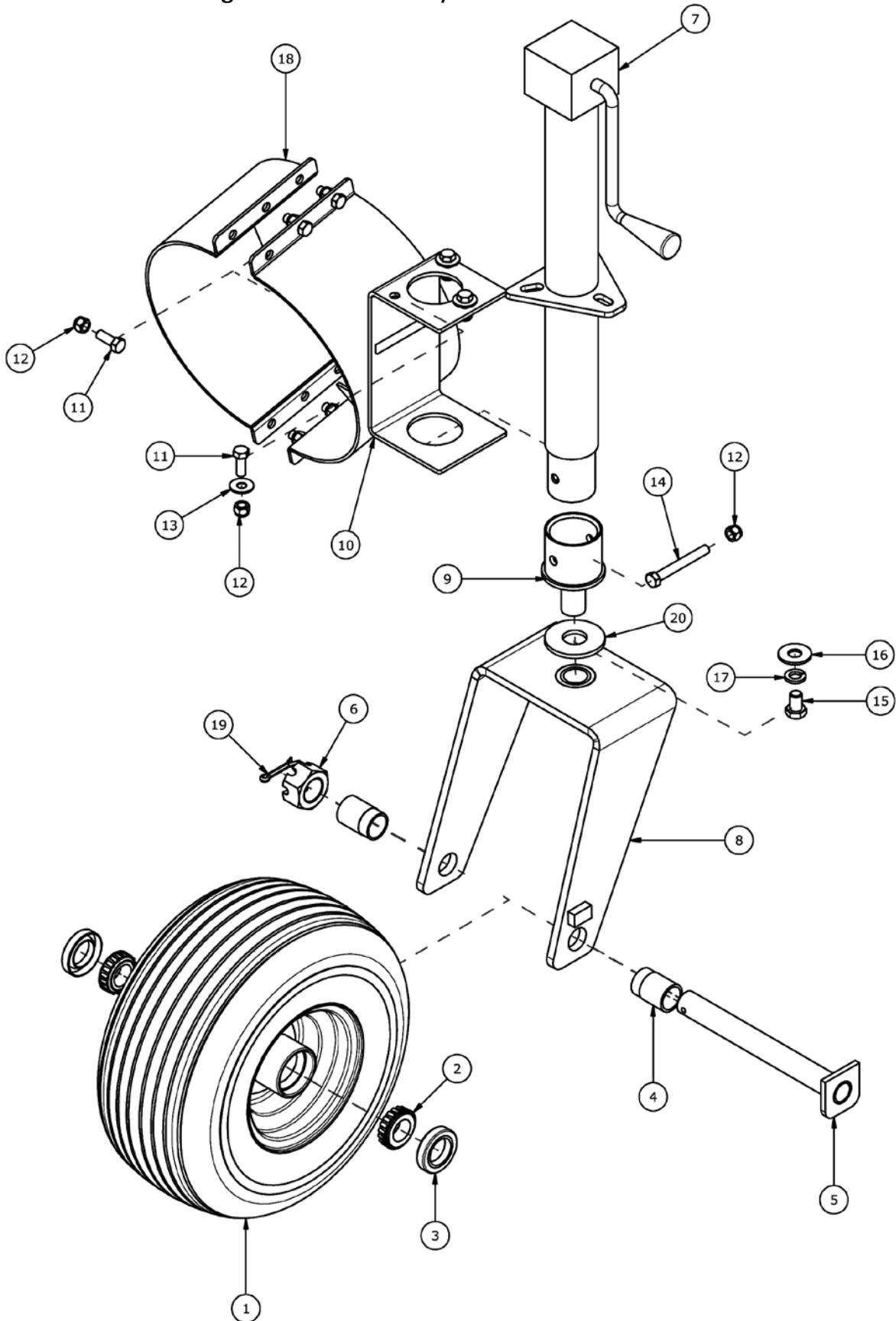

| Item | Part Number    | Description                          | Quantity |
|------|----------------|--------------------------------------|----------|
| 1    | 966195         | Tire w/ Wheel 15/600 x 6 x 4.4 Wheel | 1        |
| 2    | 966776         | Bearing Cone (L44643)                | 2        |
| 3    | 967497         | Oil Seal - SE10                      | 2        |
| 4    | 902505         | Wheel Spacer Ø1-1/4" x 1-3/4"        | 2        |
| 5    | 902489         | Wheel Yoke Pin Weldment              | 1        |
| 6    | 967498         | 1" Slotted Head Nut NF 14 (PI)       | 1        |
| 7    | SZ000642       | 2000 LB Sidewind Round Jack          | 1        |
| 8    | SZ000645       | Wheel Yoke Weldment                  | 1        |
| 9    | SZ000730       | Caster Pivot Weldment                | 1        |
| 10   | SZ000640       | Jack Half-clamp Mount                | 1        |
| 11   | SZ126065       | BLT HHCS 3/8-16 UNC 1" G5            | 9        |
| 12   | SZ125030       | Nut Lock 3/8-16 UNC Nylock           | 10       |
| 13   | SZ127002       | Washer Flat 3/8"                     | 3        |
| 14   | SZ126076       | BLT HHCS 3/8" - 16 UNC 3" G5         | 1        |
| 15   | SZ126088       | BLT HHCS, 1/2" - 13 UNC 3/4" G5      | 1        |
| 16   | SZ127003       | Washer Flat 1/2"                     | 1        |
| 17   | SZ127012       | Washer Lock, 1/2"                    | 1        |
| 18   | SZ992031210000 | 10" 3 Bolt Half-Clamp                | 1        |
| 19   | 9812433        | 3/16" x 1-1/2" Cotter Pin            | 1        |
| 20   | SZ000736       | Pivot UHMW Bearing                   | 1        |





[www.farm-king.com](http://www.farm-king.com)

# Farm King

1330 43rd Street NW  
Fargo, North Dakota USA 58102  
Ph.: 701.282.7014 | Fax: 701.282.5865  
E-mail: [info@buhler.com](mailto:info@buhler.com)  
[www.farm-king.com](http://www.farm-king.com)

Equipment shown is subject to change without notice.  
©2012 Buhler Trading Inc. Printed in USA. TSX: BUI

**bühler** | *a division of Buhler Industries Inc.*