

3815R2, 3810R2 13815R2, 13810R2

BUSH HOG®

FLEX WING ROTARY CUTTER

Revised 02/19

PARTS MANUAL SECTION 98A



An Operator's Manual was shipped with the equipment. The Operator's Manual is an integral part of the safe operation of this machine and must be maintained with the unit at all times. **READ, UNDERSTAND, and FOLLOW** the Safety and Operation Instructions contained in this manual before operating the equipment. If the Operator's Manual is not with the equipment, contact your dealer or Bush Hog to obtain a copy before operating the equipment.

Safety Video

Important Operating and Safety Instructions are found in the Mower Safety Video that can be instantly accessed on the internet at:
www.algqr.com/bve



www.algqr.com/bve

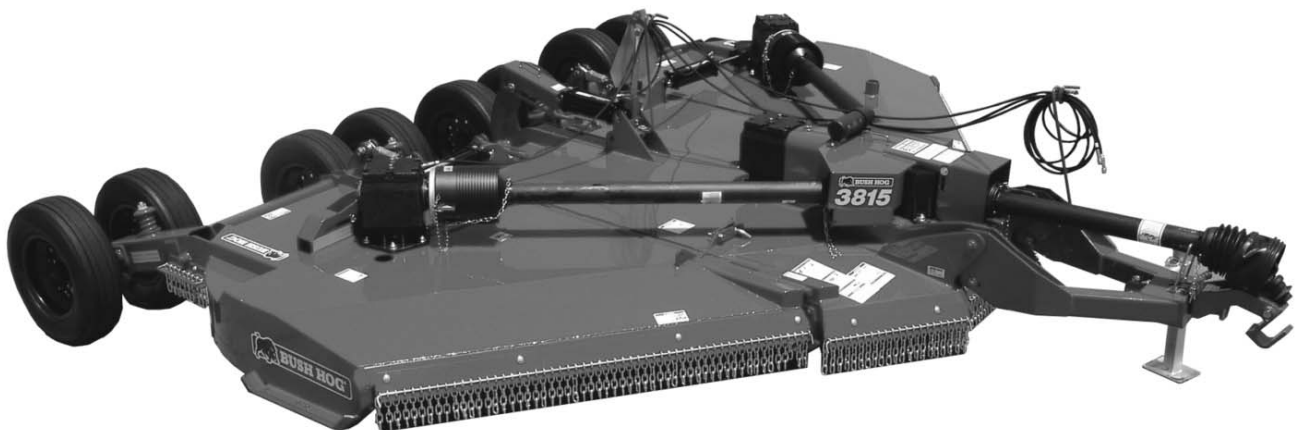

BUSH HOG®

2501 Griffin Ave.
Selma, AL 36703
Parts Ordering 1-800-304-2836
www.bushhog.com

ATENCIÓN!

LEA EL INSTRUCTIVO

Si No Lee Ingles, Pida Ayuda a Alguien
Que Si Lo Lea Para Que le Traduzca las
Medidas de Seguridad.



A MEMBER OF THE
ALAMO GROUP
ALWAYS ON THE CUTTING EDGE®

© 2014 Alamo Group Inc.

PARTS ORDERING GUIDE

The following instructions are offered to help eliminate needless delay and error in processing purchase orders for the equipment in this section.

1. The Parts Section is prepared in logical sequence and grouping of parts that belong to the basic machine featured in this manual. Part Numbers and Descriptions are given to help locate the parts and quantities required.
2. The Purchase Order must include the name and address of the person or organization ordering the parts, who should be charged, and if possible, the serial number of the machine for which the parts are ordered.
3. The Purchase Order must clearly list the quantity of each part, the complete and correct part number (be sure to include all periods), and the basic name of the part.
4. The Manufacturer reserves the right to substitute parts where applicable.
5. Some parts are unlisted items which are special production items not normally stocked and are subject to special handling. Request a quotation for such parts before sending a Purchase Order.
6. The Manufacturer reserves the right to change prices without prior notice.



For maximum safety and to guarantee optimum product reliability, always use genuine BUSH HOG Parts. The use of inferior replacement parts may cause premature or catastrophic failure which could result in serious injury or death. Direct any questions regarding parts to:

BUSH HOG
2501 Griffin Ave.
Selma, AL 36703
www.bushhog.com
Contact Us
800-304-2836



BUSH HOG®

To the Owner/Operator/Dealer

All implements with moving parts are potentially hazardous. There is no substitute for a cautious, safe-minded operator who recognizes the potential hazards and follows reasonable safety practices. The manufacturer has designed this implement to be used with all its safety equipment properly attached to minimize the chance of accidents.

BEFORE YOU START! Read the safety messages on the implement and shown in your manual. Observe the rules of safety and common sense!



DANGER

FAILING TO FOLLOW SAFETY MESSAGES AND OPERATING INSTRUCTION CAN CAUSE SERIOUS BODILY INJURY OR EVEN DEATH TO OPERATOR AND OTHERS IN THE AREA.

<p>1.</p> 	<p>2. NO RIDERS. NO CHILDREN OPERATORS</p> 	<p>3. USE SAFETY SHOES, HARD HAT, SAFETY GLASSES, SEAT BELTS, ROPS & OPS.</p> 	<p>4. BLOCK UP SECURELY BEFORE WORKING UNDER.</p> 
---	--	--	---

1. Study and understand Operator's Manuals, Safety Decals, and Instructional Decals for tractor and implement to prevent misuse, abuse, and accidents. Practice before operating in a confined area or near passersby.
 - Learn how to stop engine suddenly in an emergency. Be alert for passersby and especially children.
2. Allow no children on or near folding mower or tractor. Allow no riders on tractor or implement. Falling off may cause serious injury or death from being run over by tractor or mower or contact with rotating blades.
3. Operate only with tractor having Roll-Over Protective Structure (ROPS) and with seat belt securely fastened to prevent injury and possible death from falling off or tractor overturn.
 - Personal Protective Equipment such as Hard Hat, Safety Glasses, Safety Shoes, & Ear Plugs are recommended.
4. Block up or support raised machine and all lifted components securely before putting hands or feet under or working underneath any lifted component to prevent crushing injury or death from sudden dropping or inadvertent operation of controls. Make certain area is clear before lowering or folding.
5. Before transporting, put Lift Lever in detent or full-lift position. Install Transport Safety Devices securely on folding mowers. Put Booms securely in Transport Rest.
 - Folding and Boom Mowers have raised center of gravity. Slow down when turning and on hillsides.
6. Make certain that SMV sign, warning lights, and reflectors are clearly visible. Follow local traffic codes.
7. Never operate with Cutting Head or Folding Section raised if passersby, bystanders, or traffic are in the area to reduce possibility of injury or death from objects thrown by Blades under Guards or mower structure.
8. Before dismounting, secure implement in transport position or lower to ground.
 - Put tractor in park position or set brake, disengage PTO, stop engine, remove key, and wait until noise of rotation has ceased to prevent crushing by entanglement in rotating parts which could cause injury or death.
 - Never mount or dismount a moving vehicle. Crushing from runover may cause serious injury or death.

<p>5. TRANSPORT SAFELY, LOCK UP.</p> 	<p>6. USE SMV, LIGHTS, & REFLECTORS.</p> 	<p>7. DO NOT OPERATE WITH CUTTER OR WING RAISED</p> 	<p>8. DO NOT MOUNT OR DISMOUNT WHILE MOVING.</p> 
--	--	--	--

02967827

WARRANTY INFORMATION:

Read and understand the complete Warranty Statement found in this Manual. Fill out the Warranty Registration Form in full and return it to within 30 Days. Make certain the Serial Number of the Machine is recorded on the Warranty Card and on the Warranty Form that you retain.

LIMITED WARRANTY



Bush Hog warrants to the original purchaser of any new Bush Hog equipment, purchased from an authorized Bush Hog dealer, that the equipment be free from defects in material and workmanship for a period of one (1) year for non-commercial, state and municipalities' use and ninety (90) days for commercial use from date of retail sale. The obligation of Bush Hog to the purchaser under this warranty is limited to the repair or replacement of defective parts.

Replacement or repair parts installed in the equipment covered by this limited warranty are warranted for ninety (90) days from the date of purchase of such part or to the expiration of the applicable new equipment warranty period, whichever occurs later. Warranted parts shall be provided at no cost to the user at an authorized Bush Hog dealer during regular working hours. Bush Hog reserves the right to inspect any equipment or parts which are claimed to have been defective in material or workmanship.

DISCLAIMER OF IMPLIED WARRANTIES & CONSEQUENTIAL DAMAGES

Bush Hog's obligation under this limited warranty, to the extent allowed by law, is in lieu of all warranties, implied or expressed, **INCLUDING IMPLIED WARRANTIES OF MERCHANTABILITY AND FITNESS FOR A PARTICULAR PURPOSE** and any liability for incidental and consequential damages with respect to the sale or use of the items warranted. Such incidental and consequential damages shall include but not be limited to: transportation charges other than normal freight charges; cost of installation other than cost approved by Bush Hog; duty; taxes; charges for normal service or adjustment; loss of crops or any other loss of income; rental of substitute equipment, expenses due to loss, damage, detention or delay in the delivery of equipment or parts resulting from acts beyond the control of Bush Hog.

THIS LIMITED WARRANTY SHALL NOT APPLY:

1. To vendor items which carry their own warranties, such as engines, tires, and tubes.
2. If the unit has been subjected to misapplication, abuse, misuse, negligence, fire or other accident.
3. If parts not made or supplied by Bush Hog have been used in connection with the unit, if, in the sole judgement of Bush Hog such use affects its performance, stability or reliability.
4. If the unit has been altered or repaired outside of an authorized Bush Hog dealership in a manner which, in the sole judgement of Bush Hog, affects its performance, stability or reliability.
5. To normal maintenance service and normal replacement items such as gearbox lubricant, hydraulic fluid, worn blades, or to normal deterioration of such things as belts and exterior finish due to use or exposure.
6. To expendable or wear items such as teeth, chains, sprockets, belts, springs and any other items that in the company's sole judgement is a wear item.

NO EMPLOYEE OR REPRESENTATIVE OF BUSH HOG IS AUTHORIZED TO CHANGE THIS LIMITED WARRANTY IN ANY WAY OR GRANT ANY OTHER WARRANTY UNLESS SUCH CHANGE IS MADE IN WRITING AND SIGNED BY BUSH HOG'S SERVICE MANAGER, 2501 GRIFFIN AVE., SELMA, ALABAMA 36703.



Record the model number, serial number and date purchased. This information will be helpful to your dealer if parts or service are required.

MODEL NUMBER _____

SERIAL NUMBER _____

DATE OF RETAIL SALE _____

MAKE CERTAIN THE WARRANTY
HAS BEEN FILED WITH BUSH HOG
SELMA, ALABAMA

3815R2, 3810R2, 13815R2, 13810R2 ROTARY CUTTER

ALPHABETICAL INDEX

CONTENTS	PAGE
Axle, Center & Wing Units	98A-5-4
Axle, Single & Dual	98A-5-5
Axle, Tandem (Early Style)	98A-5-6
Axle, Tandem (Current Style)	98A-5-7
Baffle Kit	98A-6-1
Base Assembly, Center	98A-1-2, 98A-1-3
Base Assembly, R.H. Wing & L.H. Wing	98A-1-4, 98A-1-5
Blades & Blade Holders	See Base Assemblies
Chain, Safety Tow	98A-5-1
Chains, Discharge Safety	98A-2-1 through 98A-2-2
Cylinders, Hydraulic	98A-7-2
Decal Kits	98A-1-1
Driveline Holder Assembly	98A-5-2
Driveline Holder - CV EZ Mount	98A-5-3
Driveshafts, Comer / EG	98A-4-1 through 98A-4-5
Gearbox, Transfer 540 RPM (Mfg. by Comer)	98A-3-1
Gearbox, Transfer 1000 RPM (Mfg. by Bondioli & Pavesi)	98A-3-2
Gearbox, Transfer 1000 RPM (Mfg. by Comer)	98A-3-3
Gearbox, Center and L.H. Wing 540 RPM	98A-3-4
Gearbox, R.H. Wing 540 RPM	98A-3-5
Gearbox, Center 1000 RPM	98A-3-4
Gearbox, L. H. Wing 1000 RPM	98A-3-6
Gearbox, R.H. Wing 1000 RPM	98A-3-7
Hitch Assembly, Ball Type	98A-5-2
Hitch Assemblies, Swivel Pivot	98A-5-2
Hydraulic Fittings To Tractor Remotes	98A-7-1
Jackstand	98A-5-1
LED Light Kit (Rear Lights Only)	98A-1-8
Leveling Rod Assembly	98A-5-2
Shield, Wing Driveshafts	98A-2-4
Shield Assembly, Center	98A-2-3
SMV Sign & Hose Holder	98A-1-7
Tire, Airplane	98A-5-8
Tire, Solid & Foam Filled	98A-5-8 & 98A-5-9
Tongue Assembly	98A-5-1
Weight Box Assembly, 3810R2 & 13810R2	98A-1-6

DECAL KITS FOR 3815R2, 3810R2, 13815R2 & 13810R2 MODELS

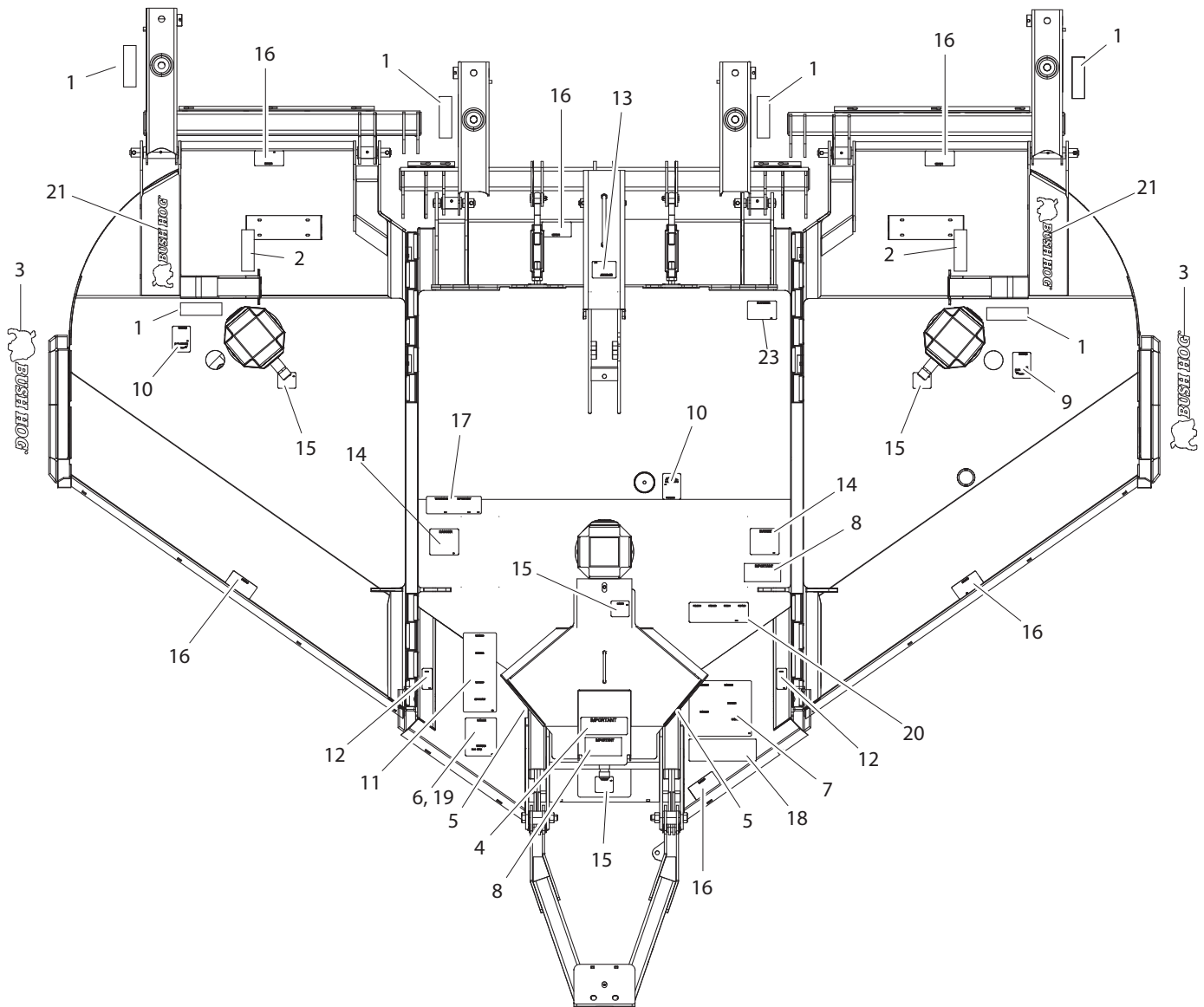

REF. NO.	PART NO.	DESCRIPTION	QTY.	REF. NO.	PART NO.	DESCRIPTION	QTY.
	50071076	Decal Kit For 3815R2/13815R2	1	9	D552	Decal, Blade Rotation CW	1
	50071077	Decal Kit For 3810R2/13810R2	1	10	D551	Decal, Blade Rotation CCW	2
1	50031212	Decal, Amber Reflector	6	11	D553	Decal, Warning	1
2	50031214	Decal, Red Reflector	2	12	D555	Decal, Danger	2
3	50061049	Decal, Bush Hog Logo	2	13	D544	Decal, Important	1
4	87340	Decal, Important	1	14	D565	Decal, Danger	2
5	50071613	Decal, Model 3815	2	15	D546	Decal, Danger	4
	50071614	Decal, Model 13815	2	16	D614	Decal, Danger (Thrown Object)	6
	50071712	Decal, Model 3810	2	17	D559	Decal, Gen. Bush Hog Parts	1
	50071713	Decal, Model 13810	2	18	D587	Decal, Lube	1
6	D547	Decal, Danger (540 RPM)	1	19	D548	Decal, Warning (1000 RPM Overlay)	1
7	D549	Decal, Sheet	1	20	D813	Decal, Danger - Multilingual	1
8	91443	Decal, Important	2	21	50065309	Decal, Bush Hog Logo	2
				22	50074259	Decal, Made In USA (Not Shown)	3
				23	D575	Decal, Danger (Crushing Hazard) (3810R2 & 13810R2 Only)	1

CENTER DECK ASSEMBLY
3815R2 & 3810R2 (540 RPM Models)
13815R2 & 13810R2 (1000 RPM Models)

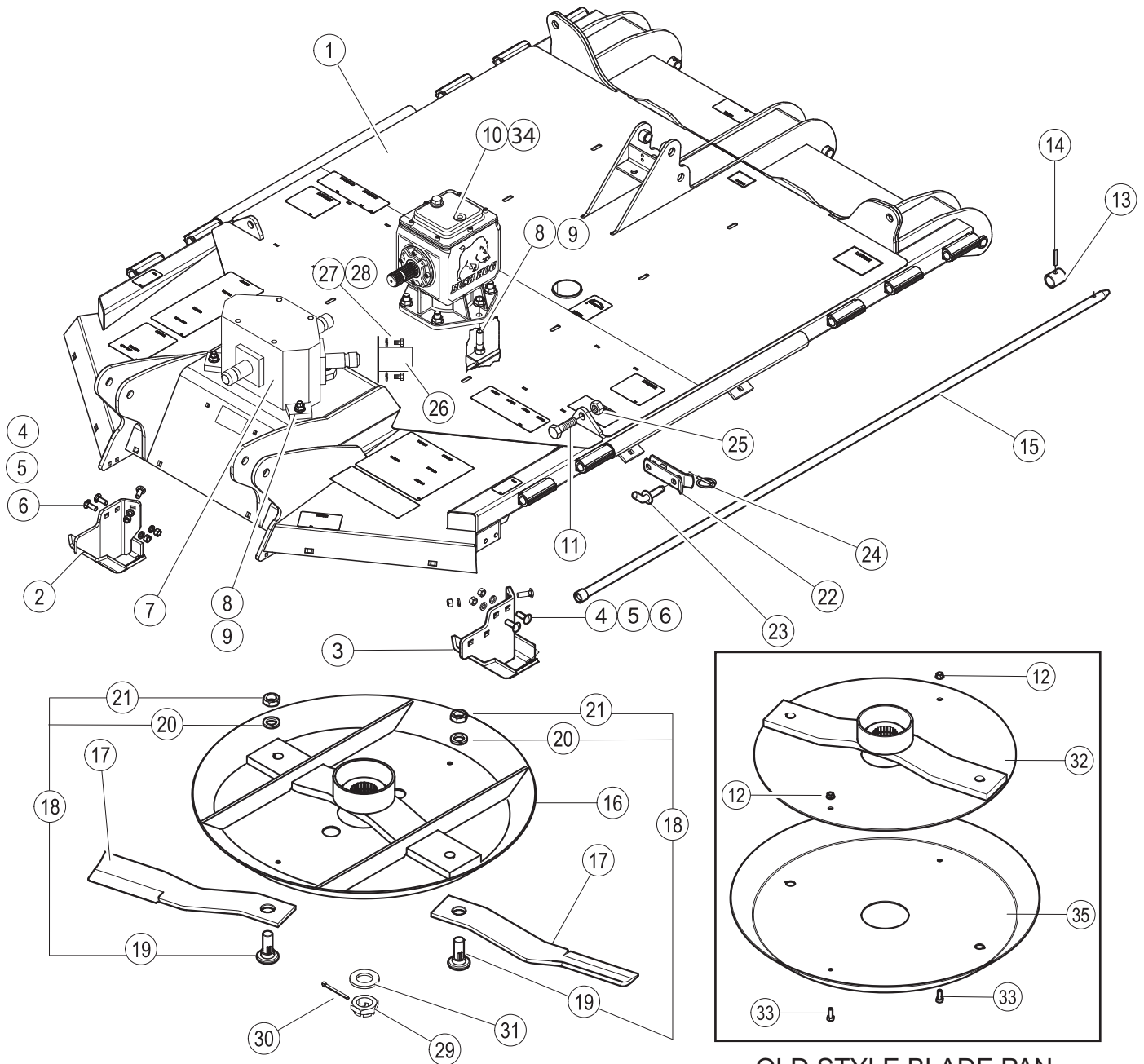

OLD STYLE BLADE PAN

Note: If item 32 alone is needed you must order item 16.
 If items 32 and 35 are needed you must order item 16.
 Item 35 can be ordered as a replacement part.

CENTER DECK ASSEMBLY
3815R2 & 3810R2 (540 RPM Models)
13815R2 & 13810R2 (1000 RPM Models)

REF. NO.	PART NO.	DESCRIPTION	QTY.	NOTES
1	50069430	Center Deck w/Decals	1	
	50069442	Center Deck w/Rings & Decals	1	
2	50076524	Skid R.H.	1	
3	50076525	Skid L.H.	1	
4	5161614	Carriage Bolt, 1/2" x 1-1/2" Gr. 5	10	
5	15806	Lockwasher, 1/2"	10	
6	8151600	Hex Nut, 1/2"	10	
7	71202	Transfer Gearbox (540 - Comer)	1	
	50071276	Transfer Gearbox (1000 - B&P)	1	
	50072724	Transfer Gearbox (1000 - Comer)	1	
8	50020970	Capscrew, 5/8" x 2-1/4" Gr. 5	10	
9	20414	Locknut, 5/8" Flanged	10	
10	50071561BH	Gearbox (540 RPM)	1	
	50071563BH	Gearbox (1000 RPM)	1	
11	1162424	Capscrew 3/4" x 2-1/2" Gr. 5	2	
12	-----	Locknut, 1/2" Flanged	2	
13	91900BH	Lock Collar	2	
14	19529	Roll Pin, 3/8" x 1-1/2"	2	
15	50069410	Hinge Rod	2	
16	50073184	Pan, Blade	1	New Style Blade Pan
17	50068273	Blade, Parallel Uplift	2	
18	63607	Blade Bolt Kit	2	
19	7919BH	Blade Bolt	2	
20	20322	Lockwasher, 1-1/8"	2	
21	252BH	Jamb Nut, 1-1/8"	2	
22	50028476	Wing Latch	2	
23	50076342	Pin	2	
24	69391	Lynch Pin	2	
25	20638	Locknut, 3/4"	2	
26	50028363	Shaft Cover (3810, 13810)	1	
27	44315BH	Capscrew, M8 x 1.25 x 25	2	
28	44311BH	Lockwasher, M8	2	
29	50071363	Caster Nut, 2"-12 (Blade Pan)	1	
30	50071364	Cotter Pin, M10 x 100	1	
31	50071362	Washer, Spring 2"	1	
32	-----	Blade Bar Weldment	1	Replaced By Item 16
33	44094BH	Capscrew 1/2" x 1-1/4" Gr.5	2	
34	50074090	Sight Window, Gearbox 90MM	1	
35	50070005	Blade Pan (Old Style)	1	

WING DECK ASSEMBLIES
3815R2 & 3810R2 (540 RPM Models)
13815R2 & 13810R2 (1000 RPM Models)
This Parts Illustration applies to RH and LH Wings.
RH WING SHOWN

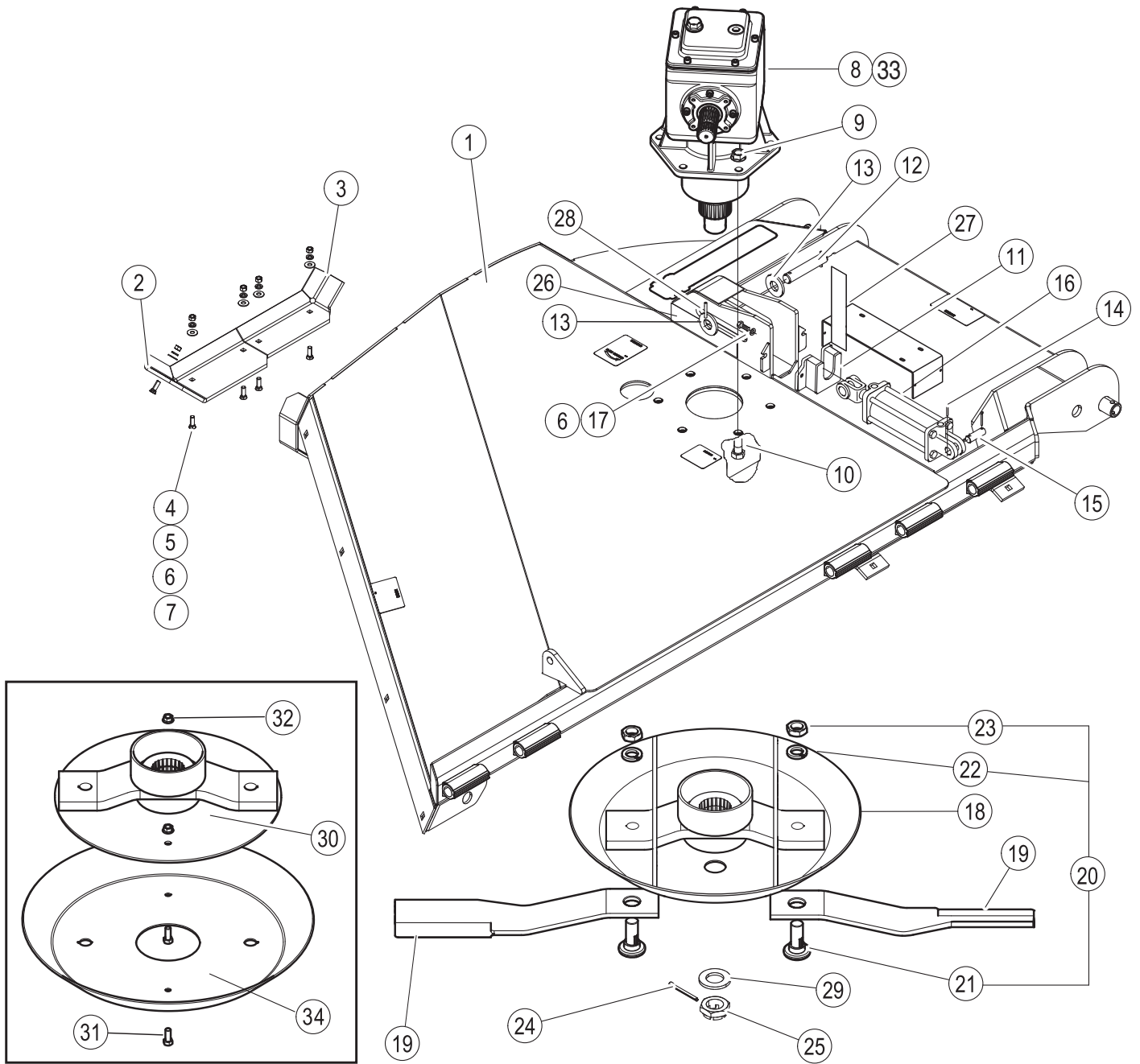

OLD STYLE BLADE PAN

Note: If item 30 alone is needed you must order item 18.
If items 30 and 34 are needed you must order item 18.
Item 34 can be ordered as a replacement part.

WING DECK ASSEMBLIES
3815R2 & 3810R2 (540 RPM Models)
13815R2 & 13810R2 (1000 RPM Models)

This Parts Listing applies to RH and LH Wings.

REF. NO.	PART NO.	DESCRIPTION	QTY.	NOTES
1	50069432	R.H. Wing Frame w/Decals	1	
	50069444	R.H. Wing Frame w/Rings & Decals	1	
	50069431	L.H. Wing Frame w/Decals	1	
	50069443	L.H. Wing Frame w/Rings & Decals	1	
2	50069372	Front Skid R.H.	1	
	50069374	Front Skid L.H.	1	
3	50069369	Rear Skid R.H.	1	
	50069371	Rear Skid L.H.	1	
4	3161212	Plow Bolt, 3/8" x 1-1/4"	5	
5	15915BH	Flatwasher, 3/8"	5	
6	15812	Lockwasher, 3/8"	6	
7	8151200	Hex Nut, 3/8"	5	
8	50071562BH	Gearbox R.H. 540 RPM	1	
	50071561BH	Gearbox L.H. 540 RPM	1	
	50071565BH	Gearbox R.H. 1000 RPM	1	
	50071564BH	Gearbox L.H. 1000 RPM	1	
9	20414	Locknut, 5/8" Flanged	6	
10	50020970	Capscrew, 5/8" x 2-1/4" Gr. 5	6	
11	50031959	Push Over Assy	1	
12	87293	Cylinder Pin	1	
13	20376	Flatwasher, 1"	2	
14	21020614	Cotter Pin, 3/16" x 1-1/2"	2	
15	95425	Pin	1	
16	99564	Wing Lift Cylinder	1	
17	20034	Capscrew, 3/8" x 1"	2	
18	50074785	Pan, Blade	1	New Style Blade Pan
19	50068273	Blade, Uplift CCW R.H. Wing	2	
	50068272	Blade, Uplift CW L.H. Wing	2	
20	63607	Blade Bolt Kit	2	
21	7919BH	Blade Bolt	2	
22	20322	Lockwasher, 1-1/8"	2	
23	252BH	Jamb Nut, 1-1/8"	2	
24	50071364	Cotter Pin M10 x 100	1	
25	50071363	Castle Nut, 2" -12 (Blade Pan)	1	
26	50031212	Reflector, Amber	1	
27	50031214	Reflector, Red	1	
28	20325	Roll Pin, 1/4" x 1-3/4"	1	
29	50071362	Washer, Spring	1	
30	-----	Blade Bar Weldment	1	Replaced By Item 18
31	44094BH	Capscrew 1/2" x 1-1/4" Gr.5	2	
32	-----	Locknut 1/2" Flanged	2	
33	50074090	Sight Window, Gearbox 90MM	1	
34	50069799	Blade Pan (Old Style)	1	

WEIGHT BOX ASSEMBLY 3810R2 & 13810R2 Models

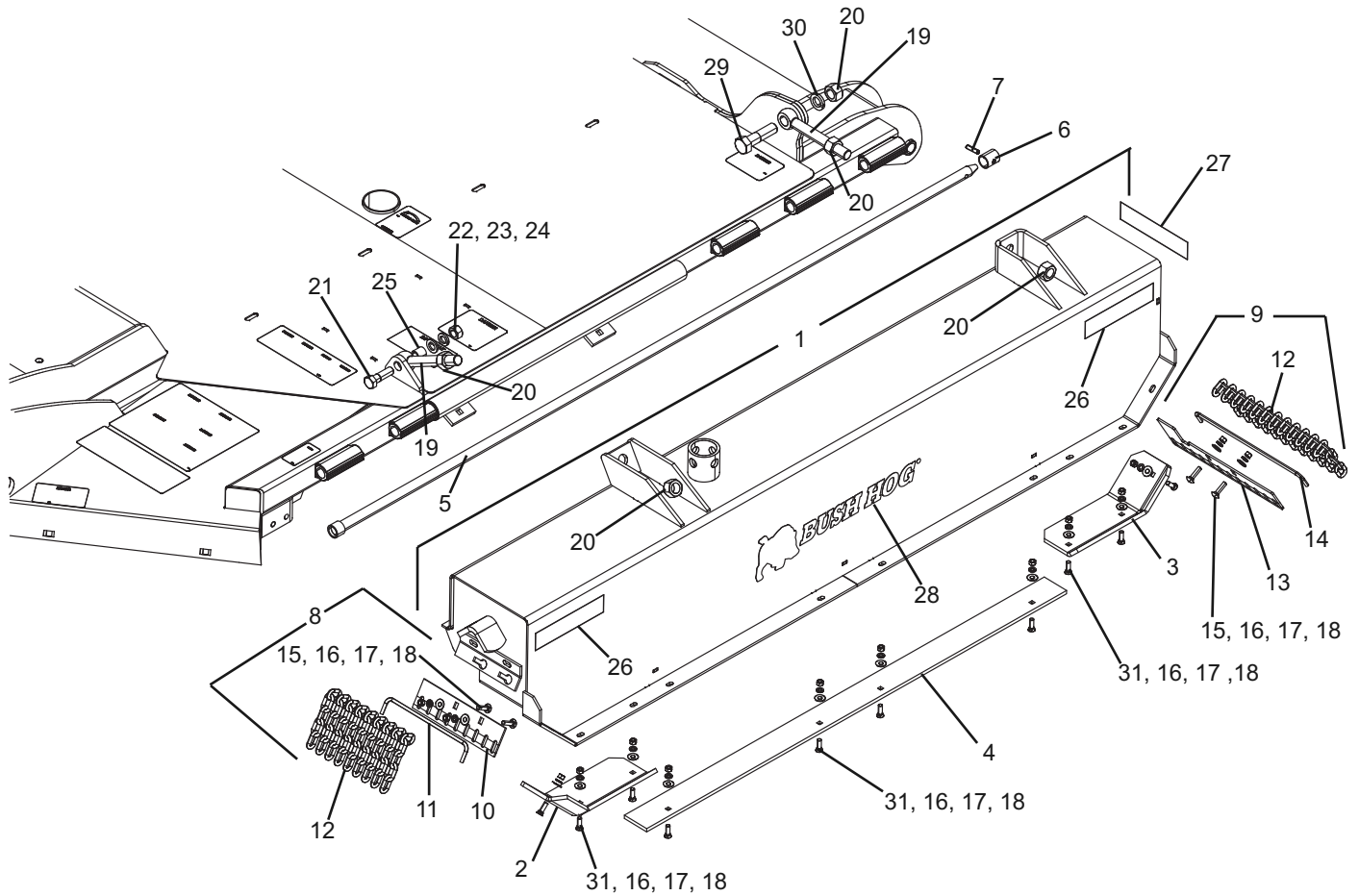

REF. NO.	PART NO.	DESCRIPTION	QTY.	REF. NO.	PART NO.	DESCRIPTION	QTY.
1	50070499	Weight Box Assy	1	15	44286	Carriage Bolt, 3/8" x 1-1/2"	4
2	50069374	Skid, Front L.H.	1	16	15915	Flatwasher, 3/8"	14
3	50069372	Skid, Front R.H.	1	17	15802	Lockwasher, 3/8"	14
4	50070514	Skid	1	18	8151200	Hex Nut, 3/8"	14
5	50069410	Hinge Rod	1	19	87052	Eyebolt	2
6	91900BH	Lock Collar	1	20	19502	Hex Nut, 1"	5
7	19529	Roll Pin, 3/8" x 1-1/2"	1	21	1162424	Capscrew, 3/4" x 2-1/2"	1
8	50070502	Chain Assy, Front (Single)	1	22	20638	Locknut, 3/4"	1
	50070500	Chain Assy, Front (Double)	1	23	146	Lockwasher, 3/4"	1
9	50070503	Chain Assy, Rear (Single)	1	24	119	Flatwasher, 3/4"	1
	50070501	Chain Assy, Rear (Double)	1	25	50038099	Bushing	1
10	50070517	Chain Support (Front)	1	26	50031212	Reflector, Amber	2
11	50069724	Rod, Chain	1	27	50031214	Reflector, Red	1
12	50017264	Chain, 5 Link (Single Row)	21	28	50061049	Decal, Bush Hog	1
	50029803	Chain, 9 Link (Double Row)	21	29	19060	Capscrew, 1" x 3-3/4"	1
13	50070519	Chain Support (Rear)	1	30	15821	Lockwasher, 1"	1
14	50070518	Rod, Chain	1	31	3161212	#3 Hd Plow Bolt, 3/8" x 1-1/4" Gr. 5	10

**SMV SIGN & HOSE HOLDER
FOR 3815R2 & 3810R2, 13815R2 & 13810R2 MODELS**

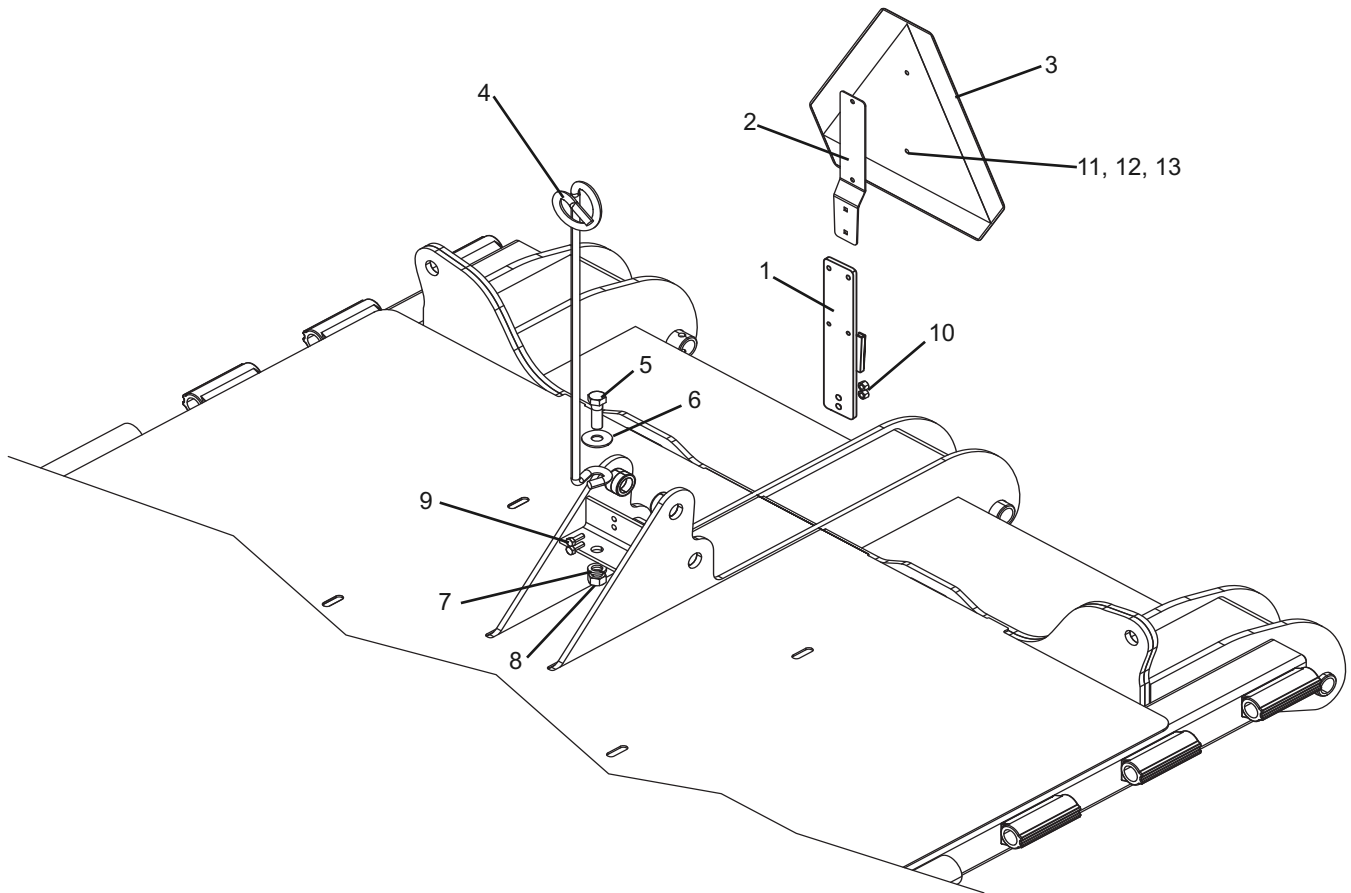

REF. NO.	PART NO.	DESCRIPTION	QTY.
1	50074198	SMV Mount Weldment	1
2	2438621	SMV Spade Bracket	1
3	94359	SMV Sign	1
4	12031	Rod, Hose Holder	1
5	20947	Cap screw, 5/8" x 2" Gr. 5	1
6	15925	Flatwasher, 5/8"	1
7	19486	Lockwasher, 5/8"	1
8	15563	Hex Nut, 5/8"	1
9	1161010	Cap screw, 5/16" x 1" Gr. 5	2
10	15602BH	Locknut, 5/16"	2
11	1160807	Cap screw, 1/4" x 7/8" Gr. 5	2
12	15905	Lockwasher, 1/4"	2
13	15531BH	Hex Nut, 1/4"	2

LED LIGHT KIT (REAR LIGHTS ONLY)

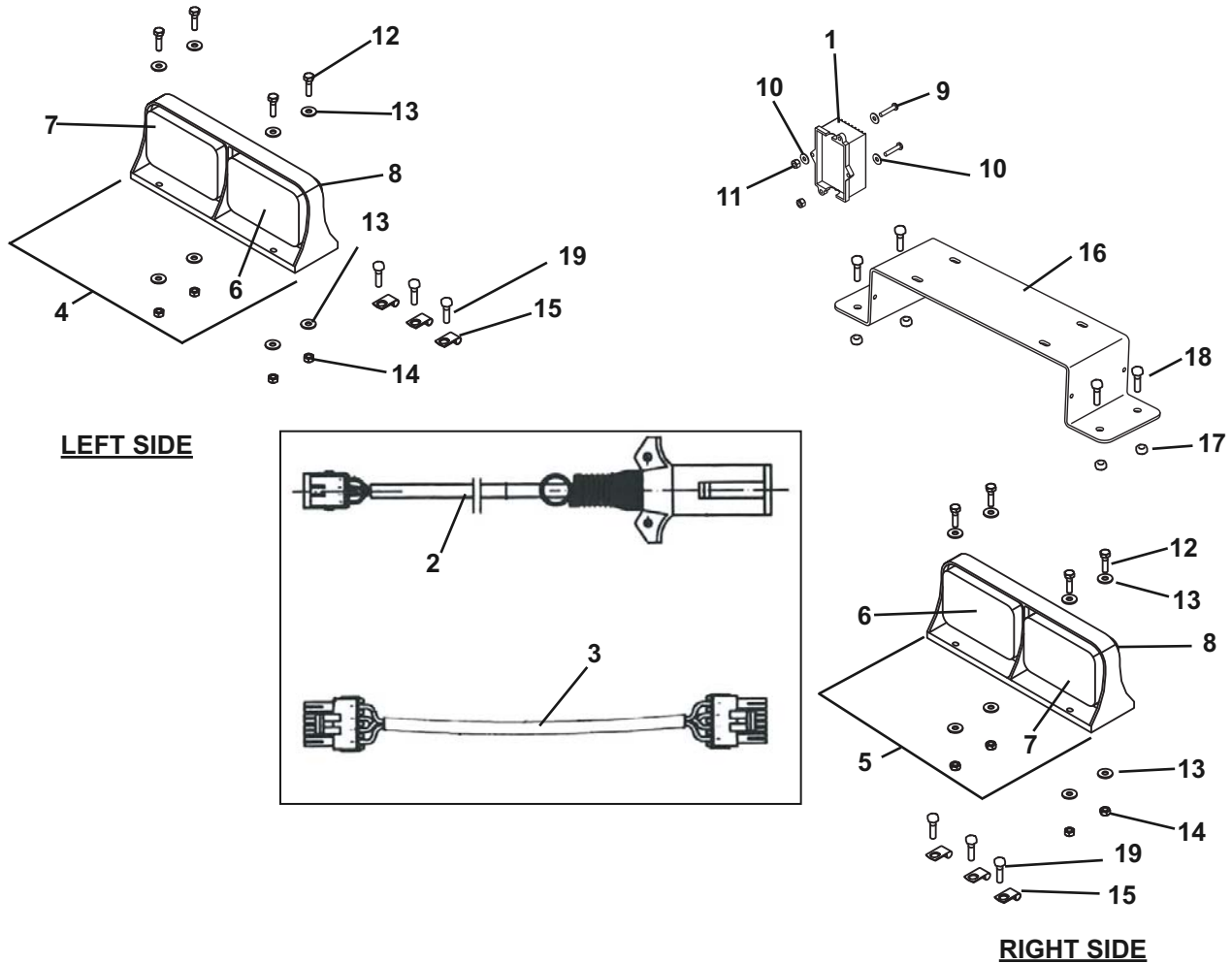

REF. NO.	PART NO.	DESCRIPTION	QTY.
	50074720	Light Kit (Items 1-8)	1
1	50072057	Module, Enhance	1
2	50074721	Main Harness (7 Pin, 16' Long)	1
3	50074725	Wishbone Harness, (8' Long)	2
4	50074723	Dual LED Ag Lamp, Left Side, Amber/Red	1
5	50074724	Dual LED Ag Lamp, Right Side, Red/Amber	1
6	50072062	Lens, Red Replacement	2
7	50072063	Lens, Amber Replacement	2
8	50072064	Cover, Black Replacement Lens	4
	50076234	Field Light Installation Kit for Early Models (Includes the 50074720 Light Kit)	1
9	4130610	Slit Pn Hd Mach Screw, #10 x 1"	2
10	17020600	Flatwasher, #10	3
11	44520BH	Locknut, #10	2
12	44186BH	Capscrew, 1/4" x 1" Gr. 5	8
13	15918BH	Flatwasher, 1/4"	16
14	15608	Locknut, 1/4" Gr. C	8
15	50074735	Clamp	6
16	50076322	Light Bracket	2
17	44521	Flanged Locknut 5/16"	8
18	1161006	Capscrew 5/16" x 3/4"	8
19	50043225	Self Tapping Screw Washer Hd. 5/16" x 3/4"	6

FRONT AND REAR SINGLE ROW HIGHWAY CHAINS

3815R2 & 3810R2 (540 RPM Models)
13815R2 & 13810R2 (1000 RPM Models)

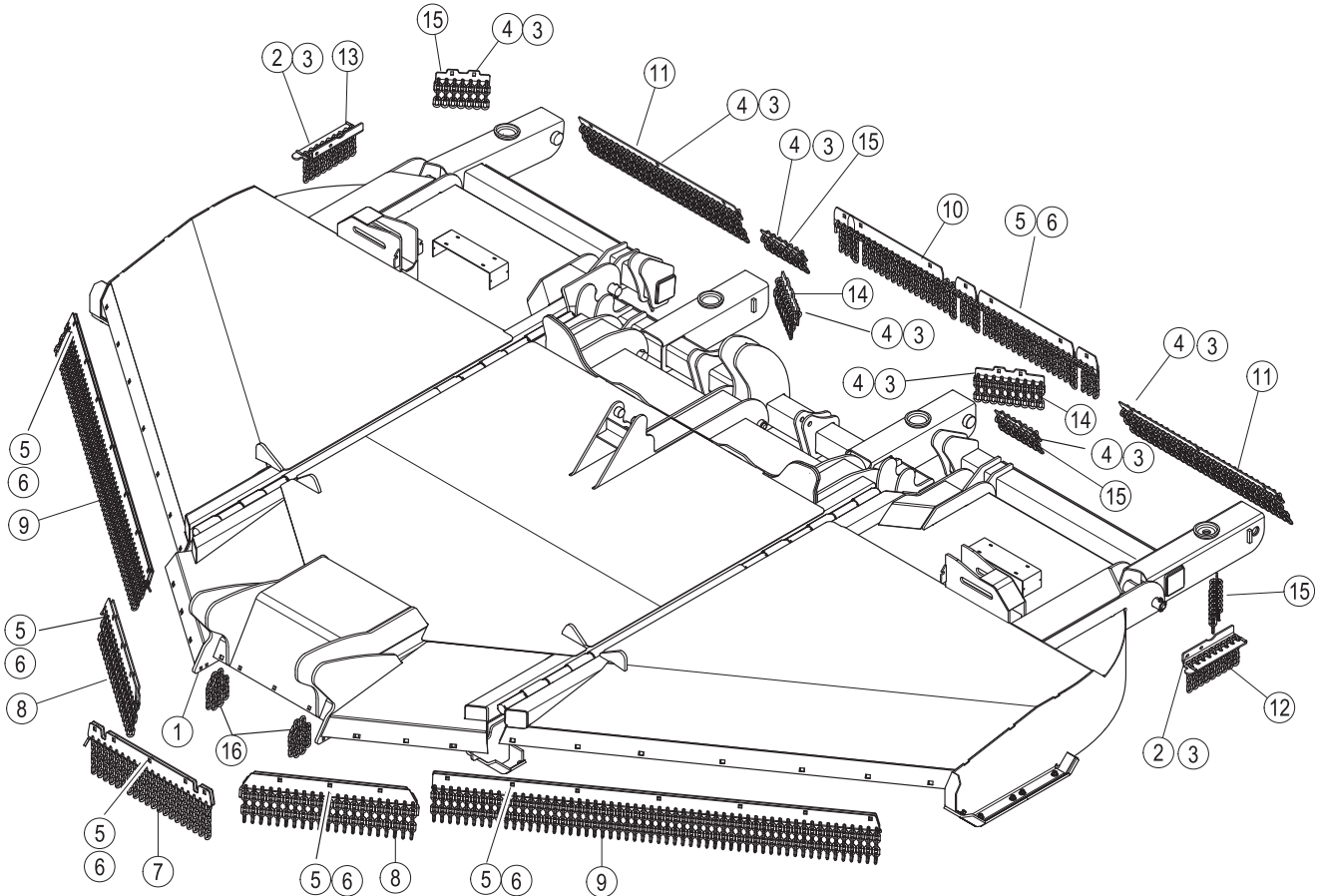

REF. NO.	PART NO.	DESCRIPTION	QTY.	REF. NO.	PART NO.	DESCRIPTION	QTY.
1	44286	Carriage Bolt, 3/8" x 1-1/2" Gr. 5	8	11	50069736	Rear Wing Chain Assy	2
2	45129BH	Capscrew, 3/8" x 1-1/4" Gr. 5	4		50069728	Chain Support, Wing Axle	1
3	45073	Hex Nut, 3/8"	26		50069722	Rod, Chain - 28 Slots	1
4	5161212	Carriage Bolt, 3/8" x 1-1/4"	18		50017211	Chain, Plated - 6 Link	28
5	5161614	Carriage Bolt, 1/2" x 1-1/2"	23	12	50069739	Chain Assy, L.H. Wing	1
6	19518	Flanged Lock Nut, 1/2"	32		50069731	Chain Mount, Wing, L.H.	1
7	50071747	Front Center Chain Assy	1		50069724	Rod, Chain - 9 Slots	1
	50071744	Front Center Chain Support	1		50018912	Chain, Plated - 4 Link	9
	50071829	Rod, Chain - 20 Slots	1	13	50069738	Chain Assy, R.H. Wing	1
	50017264	Chain, Plated - 5 Link	20		50069730	Chain Mount, Wing R.H.	1
8	50071748	Front Outside Chain Assy	2		50069724	Rod, Chain - 9 Slots	1
	50071742	Front Outside Chain Support	1		50018912	Chain, Plated - 4 Link	9
	50071831	Rod, Chain - 21 Slots	1	14	50071185	Chain Assy Wing Axle, Inside	2
	50017264	Chain, Plated - 5 Link	21		50071184	Chain Support, Wing Axle, Inside	1
9	50071746	Front Wing Chain Assy	2		50078346	Chain Cable	1
	50071622	Front Support	1		50018912	Chain, Plated - 4 Link	9
	50069719	Rod, Chain - 56 Slots	1		50050408	Stop Sleeve	2
	50017264	Chain, Plated - 5 Link	56	15	50069737	Chain Assy Wing Axle	4
10	50069740	Rear Center Chain Assy	1		50069729	Chain Support, Wing Axle	1
	50069741	Rear Support	2		50073323	Chain Cable	1
	50069742	Rear Support	3		50018912	Chain, Plated - 4 Link	7
	50069743	Chain Rod, Rear Center Deck	1		50050408	Stop Sleeve	2
	50017264	Chain, Plated - 5 Link	41	16	50029803	Chain, Plated - 9 Link	4
	50018912	Chain, Plated - 4 Link	4				

FRONT AND REAR DOUBLE ROW HIGHWAY CHAINS

3815R2 & 3810R2 (540 RPM Models)
13815R2 & 13810R2 (1000 RPM Models)

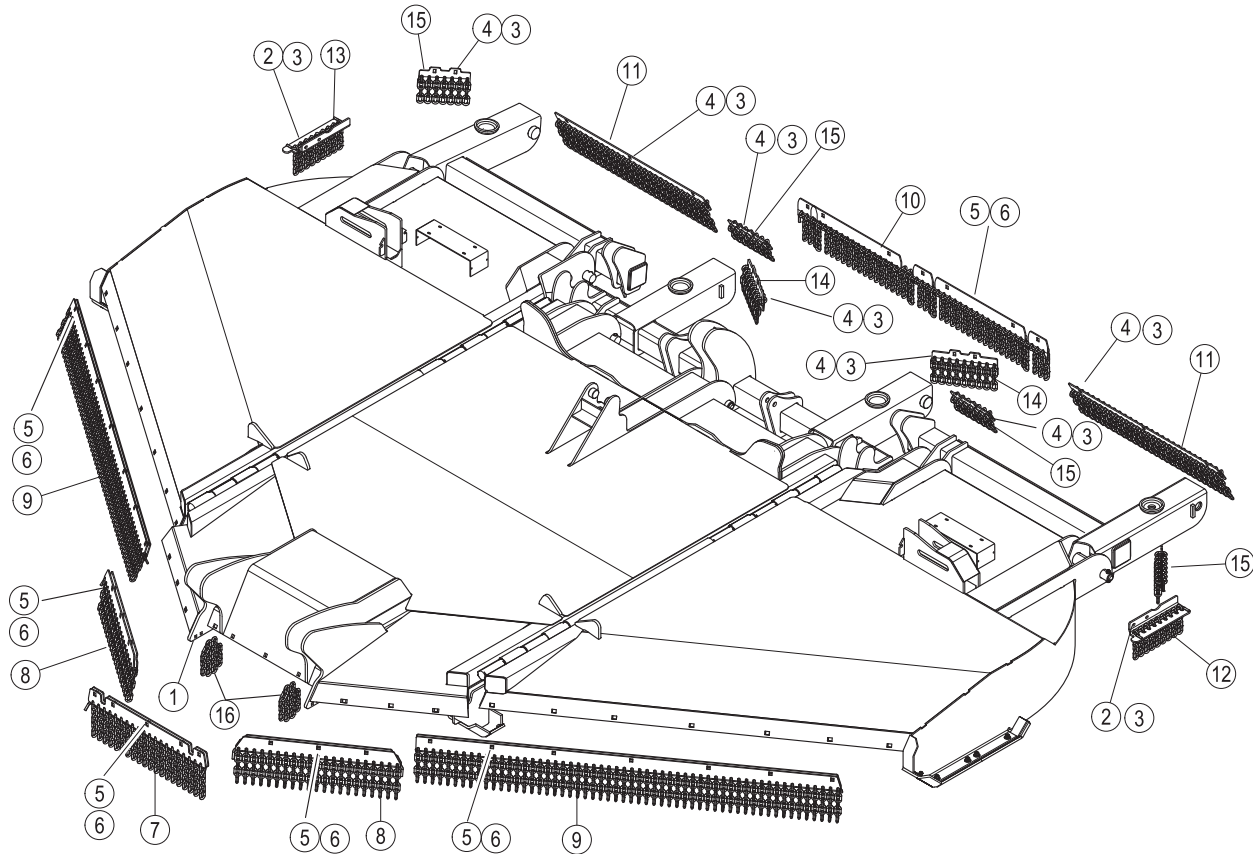

REF. NO.	PART NO.	DESCRIPTION	QTY.	REF. NO.	PART NO.	DESCRIPTION	QTY.
1	44286	Carriage Bolt, 3/8" x 1-1/2" Gr. 5	8	11	50070271	Rear Wing Chain Assy	2
2	45129BH	Capscrew, 3/8" x 1-1/4" Gr. 5	4	50069728	Chain Support, Wing Axle	1	
3	45073	Hex Nut, 3/8"	26	50069722	Rod, Chain - 28 Slots	1	
4	5161212	Carriage Bolt, 3/8" x 1-1/4"	18	50017213	Chain, Plated - 11 link	28	
5	5161614	Carriage Bolt, 1/2" x 1-1/2"	23	12	50070273	Chain Assy, L.H. Wing	1
6	19518	Flanged Lock Nut, 1/2"	32	50069731	Chain Mount, Wing, L.H.	1	
7	50071750	Front Center Chain Assy	1	50069724	Rod, Chain - 9 Slots	1	
	50071744	Front Center Chain Support	1	50017212	Chain, Plated - 7 Link	9	
	50071829	Rod, Chain - 20 Slots	1	13	50070274	Chain Assy, R.H. Wing	1
	50029803	Chain, Plated - 9 Link	20	50069730	Chain Mount, Wing, R.H.	1	
8	50071751	Front Outside Chain Assy	2	50069724	Rod, Chain - 9 Slots	1	
	50071742	Front Outside Chain Support	1	50017212	Chain, Plated - 7 Link	9	
	50071831	Rod, Chain - 21 Slots	1	14	50071187	Chain Assy Wing Axle, Inside	2
	50029803	Chain, Plated - 9 Link	21	50071184	Chain Support, Wing Axle, Inside	1	
9	50071749	Front Wing Chain Assy	2	50078346	Chain Cable	1	
	50071622	Front Support	1	50029803	Chain, Plated - 9 Link	9	
	50069719	Rod, chain - 56 Slots	1	50050408	Stop Sleeve	2	
	50029803	Chain, Plated - 9 Link	56	15	50070272	Chain Assy Wing Axle	4
10	50070270	Rear Center Chain Assy	1	50069729	Chain Support, Wing Axle	1	
	50069741	Rear Support	2	50073323	Chain Cable	1	
	50069742	Rear Support	3	50017212	Chain, Plated - 7 Link	7	
	50069743	Chain Rod, Rear Center Deck	1	50040408	Stop Sleeve	2	
	50029803	Chain, Plated - 9 Link	41	16	50029803	Chain, Plated - 9 Link	4
	50017212	Chain, Plated - 7 Link	4				

CENTER SHIELD ASSEMBLY

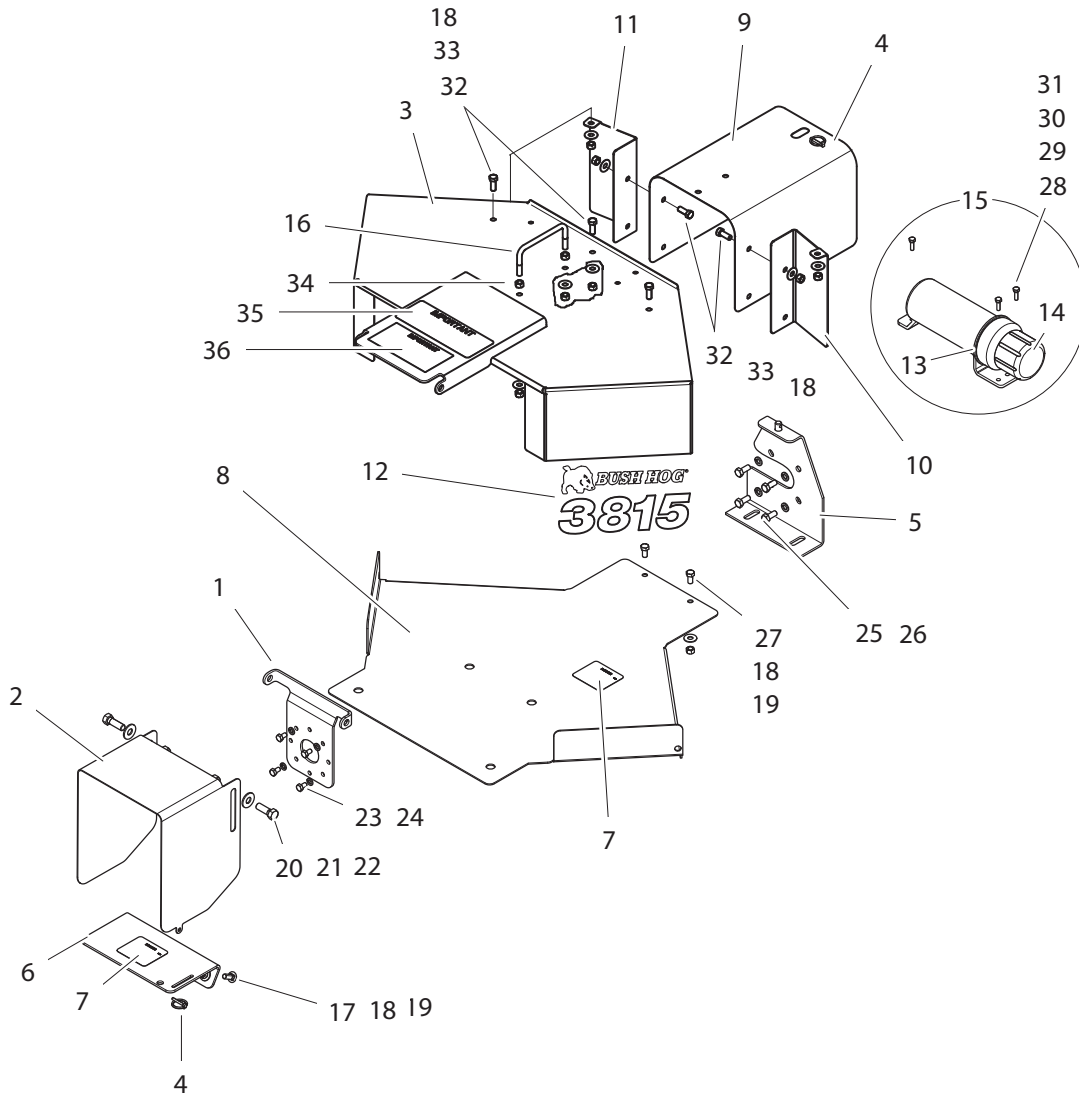

REF. NO.	PART NO.	DESCRIPTION	QTY.	REF. NO.	PART NO.	DESCRIPTION	QTY.
1	50068964	Pivot Bracket	1	18	9131200	Locknut, 3/8"	9
2	50069383	Shield, Input	1	19	15915BH	Flatwasher, 3/8"	4
3	50069455	Shield w/Decals	1	20	15093	Capscrew, 1/2" x 1-1/2"	2
4	69391	Lynch Pin	2	21	15916	Flatwasher, 1/2"	2
5	50070528	Rear Shield Support	1	22	15554	Locknut, 1/2"	2
6	50069424	Input Shield Bottom w/Decal	1	23	90560	Capscrew, M8 x 1.25 x 15	4
7	D546	Decal, Danger	2	24	44311BH	Lockwasher, M8	4
8	50069425	Center Shield Bottom w/Decal	1	25	45244BH	Capscrew, M10 x 1.5 x 25	4
9	50068977	Shield, Rear	1	26	45239	Lockwasher, M10	4
10	50070532	Shield, Transfer L.H.	1	27	45088BH	Capscrew, 3/8" x 3/4" Gr.5	2
11	50070530	Shield, Transfer R.H.	1	28	1160807	Capscrew, 1/4" x 7/8"	3
12	50071613	Model Decal 3815	2	29	15918BH	Flatwasher, 1/4"	3
	50071614	Model Decal 13815	2	30	15905	Lockwasher, 1/4"	3
	50071712	Model Decal 3810	2	31	15531BH	Hex Nut, 1/4"	3
	50071713	Model Decal 13810	2	32	45086BH	Capscrew, 3/8" x 1" Gr.5 YZ	7
13	50035830	Seal, Cap	1	33	45063	Flatwasher, 3/8" YZ	9
14	50035831	Cap, Canister	1	34	45073	Hex Nut, 3/8" YZ	2
15	50035829	Canister Assembly	1	35	87340	Decal, Important Lube	1
16	50027637	U-Bolt	1	36	91443	Decal, Important Slip Clutch	1
17	44109BH	Carriage Bolt, 3/8" x 1" Gr.5	2				

WING DRIVELINE SHIELDING

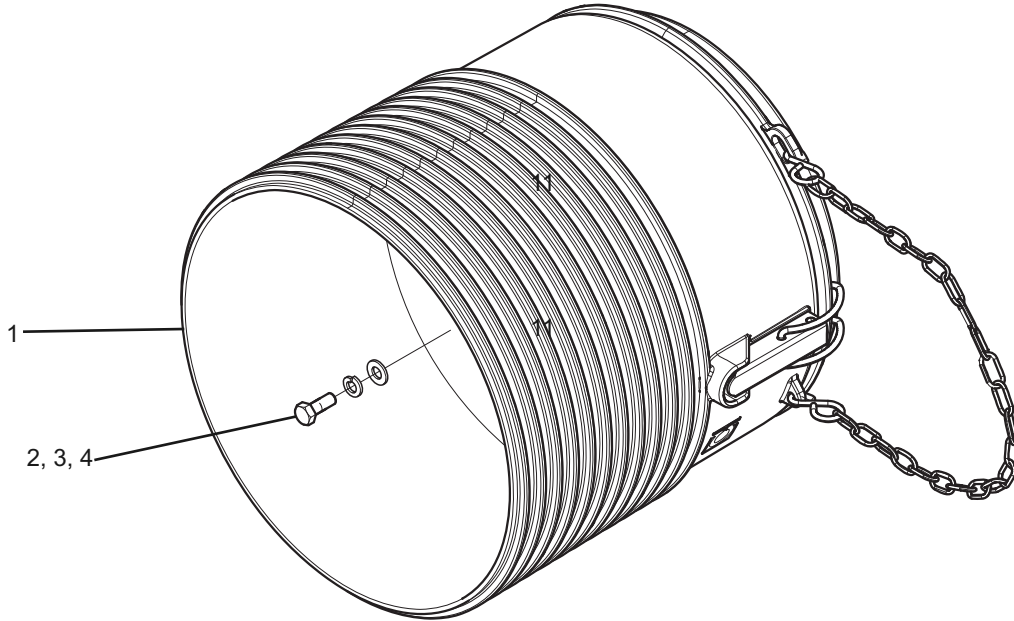

REF. NO.	PART NO.	DESCRIPTION	QTY.
1	50062095	Driveling Shield Cone	1
2	90560	Capscrew, M8 x 1.25 x 15	4
3	44311BH	Lockwasher, M8	4
4	44216	Flatwasher, M8	4

71202 TRANSFER GEARBOX ASSEMBLY. - 540 RPM

MFG. BY COMER

MODEL 3815R2 & 3810R2 (540 RPM)

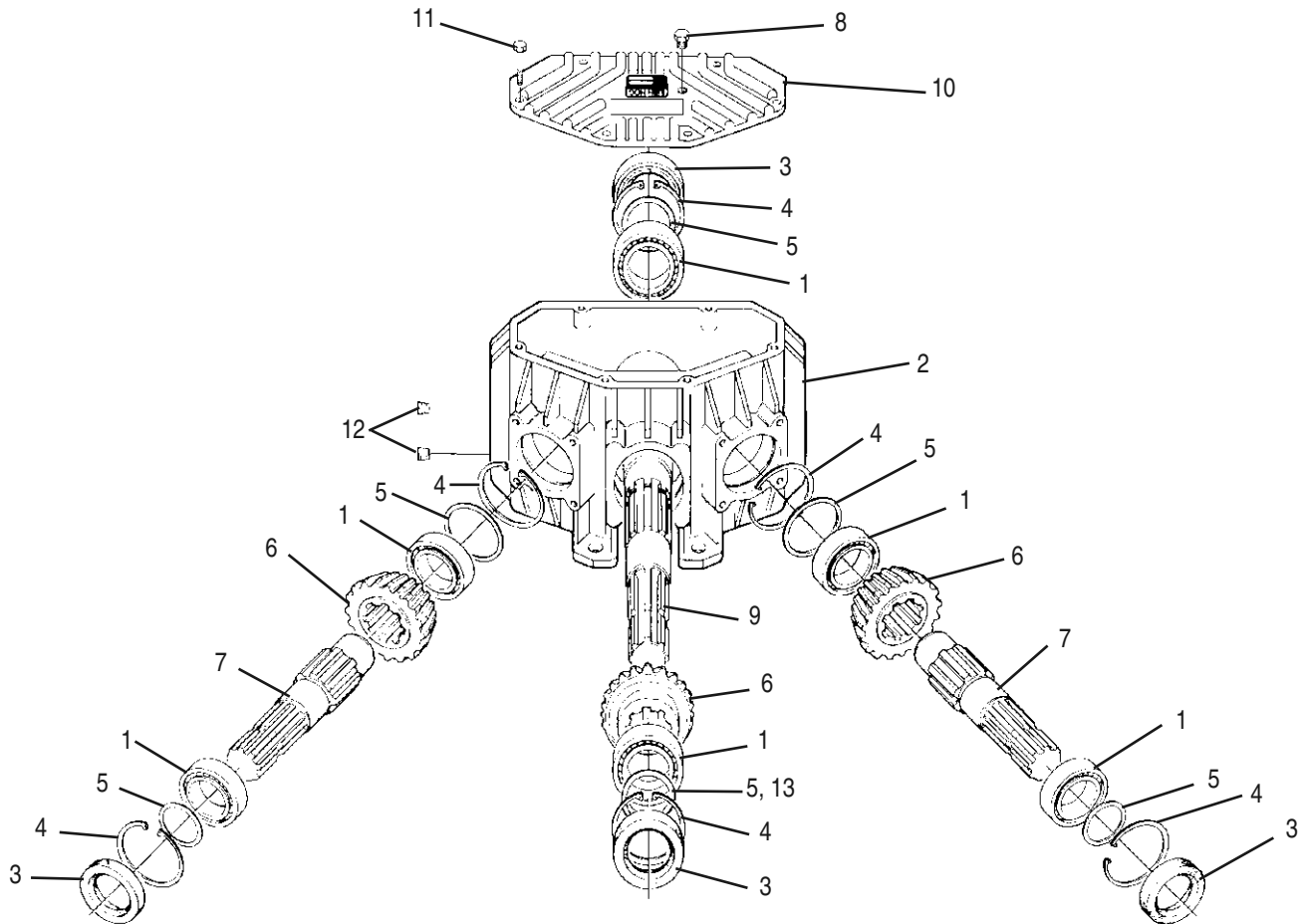

REF. NO.	PART NO.	DESCRIPTION	QTY.
	71202	Assembly, Transfer Gearbox	1
1	70796	Bearing	6
2	76671	Casing	1
3	50068116	Oil Seal	4
4	70881	Snap Ring	6
5	70752	Shim .3	6
6	50076037	Gear Kit (1 - 24T & 2 - 20T Gears)	1
7	76673	Shaft, 1-3/4" Z20	2
8	80538	Vent Plug	1
9	76675	Shaft, 1-3/4" Z20	1
10	76676	Cover	1
11	44489BH	Capscrew M10 x 1.5 x 35 Gr. 8.8	6
12	70181	Gas Plug, 3/8"	2
13	70753	Shim .4	6
	70754	Shim .5	6
	70755	Shim .6	6

50071276 TRANSFER GEARBOX ASSEMBLY - 1000 RPM
MODEL 13815R2 & 13810R2 (1000 RPM)
MFG. BY BONDIOLI & PAVESI

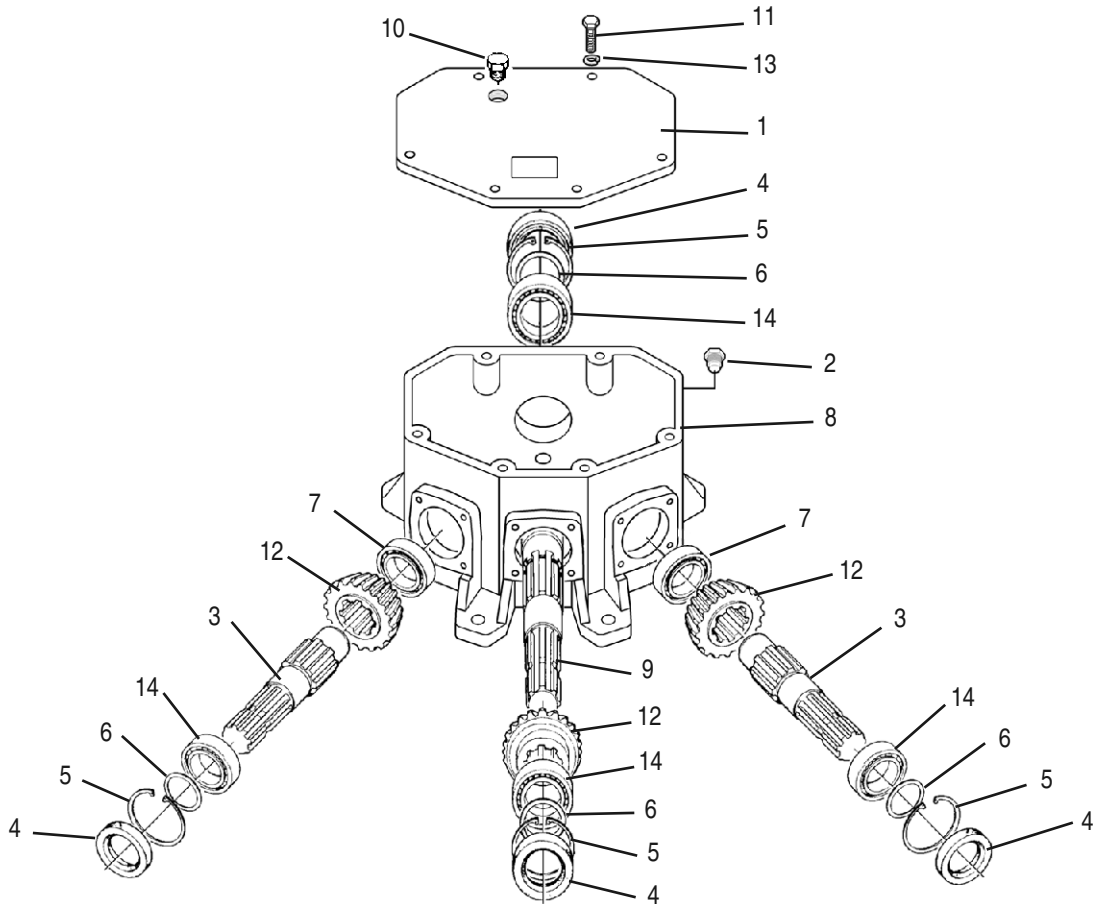

REF. NO.	PART NO.	DESCRIPTION	QTY.
	50071276	Assembly, Transfer Gearbox	1
1	50066914	Top Cover	1
2	50066915	Drain Plug (Magnetic)	1
3	50066917	Output Shafts 1-3/4" 20 Spline	2
4	50068116	Oil Seal	4
5	50066919	Snap Ring 85 x 4mm	4
6	50066920	Shim Kit	4
7	70797	Bearing 35 x 72 x 18.25mm	2
8	50066922	Housing	1
9	50066923	Input Shaft	1
10	50066924	Breather Plug (Gas) 3/8"	1
11	50066925	Capscrew M10 x 22 x 1.5 C8.8	6
12	50071875	Gear Set for 1000 RPM (Two 27 Tooth Gears and One 20 Tooth Gear)	1
13	44198	Lockwasher, M10	6
14	70796	Bearing	4

50072724 TRANSFER GEARBOX ASSEMBLY - 1000 RPM
MODEL 13815R2 & 13810R2 (1000 RPM)
MFG. BY COMER

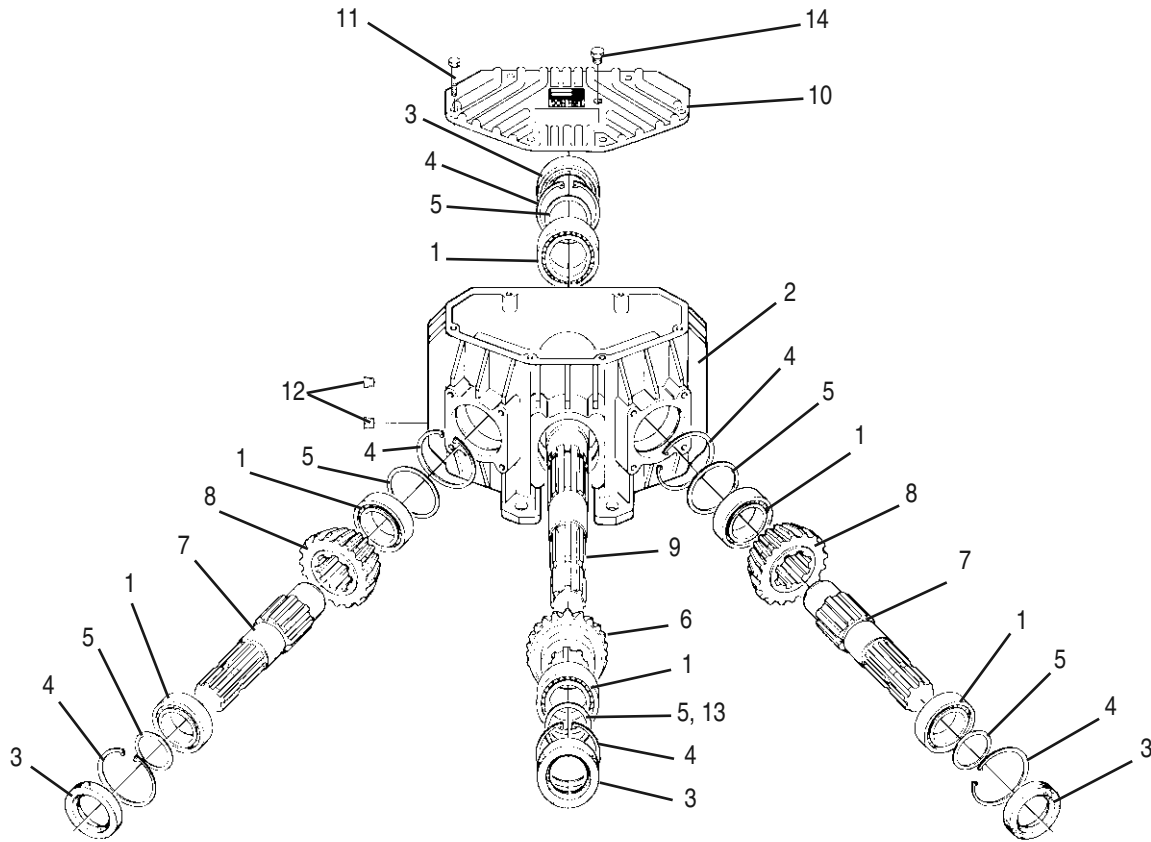

REF. NO.	PART NO.	DESCRIPTION	QTY.
	50072724	Assembly, Transfer Gearbox	1
1	70796	Bearing	6
2	76671	Casing	1
3	50068116	Oil Seal	4
4	70881	Snap Ring	6
5	70752	Shim .3	6
6	50075082	Gear, Set (1000 RPM)	1
7	76673	Shaft, 1-3/4" Z20	2
8	50075082	Gear, Set (1000 RPM)	2
9	76675	Shaft, 1-3/4" Z20	1
10	76676	Cover	1
11	44489BH	Capscrew M10 x 1.5 x 35 Gr. 8.8	6
12	70181	Gas Plug, 3/8"	2
13	70753	Shim .4	6
	70754	Shim .5	6
	70755	Shim .6	6
14	80538	Vent Plug	1

**50071561BH - GEARBOX ASSY, EZ225B, RATIO 1:1.6, (540 RPM)
 CENTER - 3815R2 & 3810R2/LH WING - 3815R2
 50071563BH - GEARBOX ASSY, EZ225B, RATIO 1.15:1, (1000 RPM)
 CENTER - 13815R2 & 13810R2**

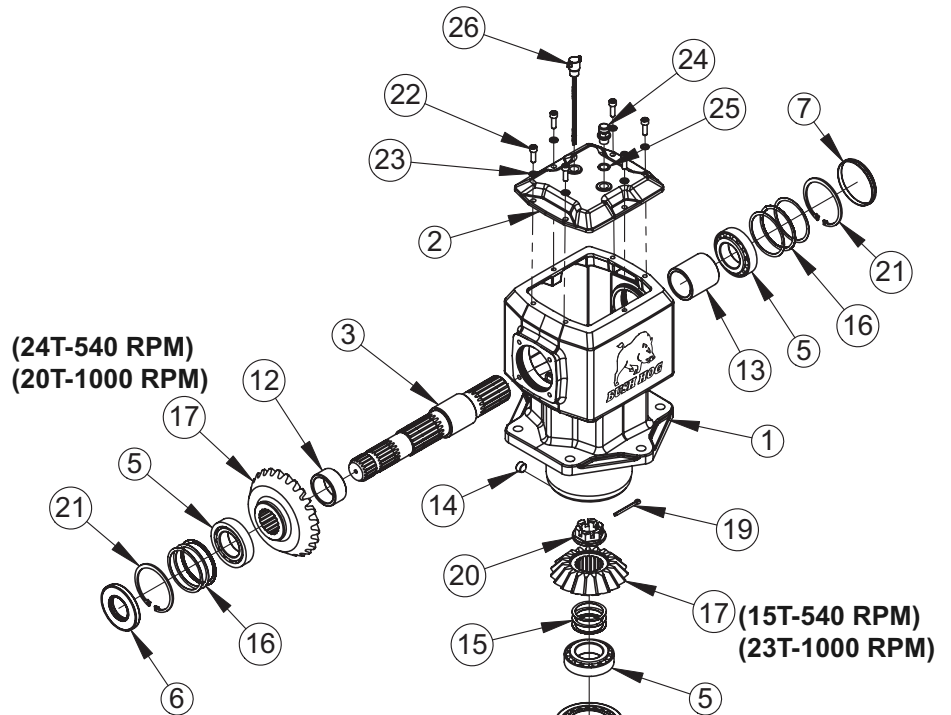

REF. NO.	PART NO.	DESCRIPTION	QTY.
	50071561BH	Gearbox Assembly (For Mod. 3815R2 & 3810R2)	1
	50071563BH	Gearbox Assembly (For Model 13815R2 & 13810R2)	1
1	-----	Housing	1
2	00790887	Cap, Top	1
3	00790924	Shaft, Input	1
4	50069790	Shaft, Output	1
5	00779007	Bearing, Tapered Roller (90 x 50 x 24.75) 32210	3
6	00790889	Seal, Oil 90 x 44 x 10	1
7	50074090	Sight Window, Gearbox 90MM (Must Be Ordered Sep.)	1
8	00790928	Bearing, Tapered Roller (125 x 75 x 37) 33115	1
9	50069791	Protector, Seal	1
10	00790931	Ring, Internal Snap 125 x 3	2
11	00790930	Seal, Oil 101.6 x 125 x 12	1
12	00790932	Spacer, Small - Input	1
13	00790933	Spacer, Large - Input	1
14	13033	Plug, Socket Head, 3/8"-18 NPT	1
15	00790939	Kit, HD225 Shim	1
16	00790892	Kit, Input Shim	2
17	00790934	Kit, Gear 1:1.6 Ratio (24T & 15T) - 50071561	1
	00790947	Kit, Gear 1.15:1 Ratio (23T & 20T) - 50071563	1
19	70497	Cotter Pin, M5 x 50	1
20	00790937	Hex Nut, Slotted Flg, M30-2.0	1
21	00790891	Ring, Internal Snap, 90 x 3	2
22	00790896	Bolt, Socket Hd, M8 x 1.25 x 20	6
23	701611C	Lockwasher, M8	6
24	00790985	Plug, Vent, M16-1.5	1
25	00790983	Washer, Sealing, M16	1
26	4038612	Dipstick, Oil	1
28	50071362	Washer, Spring 2"	1
29	50071363	Hex Nut, Slotted Jam, 2"-12	1
30	50071364	Cotter Pin, 10MM x 100MM	1

**50071562BH - GEARBOX ASSY, EZ225B, RATIO 1:1.6, (540 RPM)
RH WING - 3815R2**

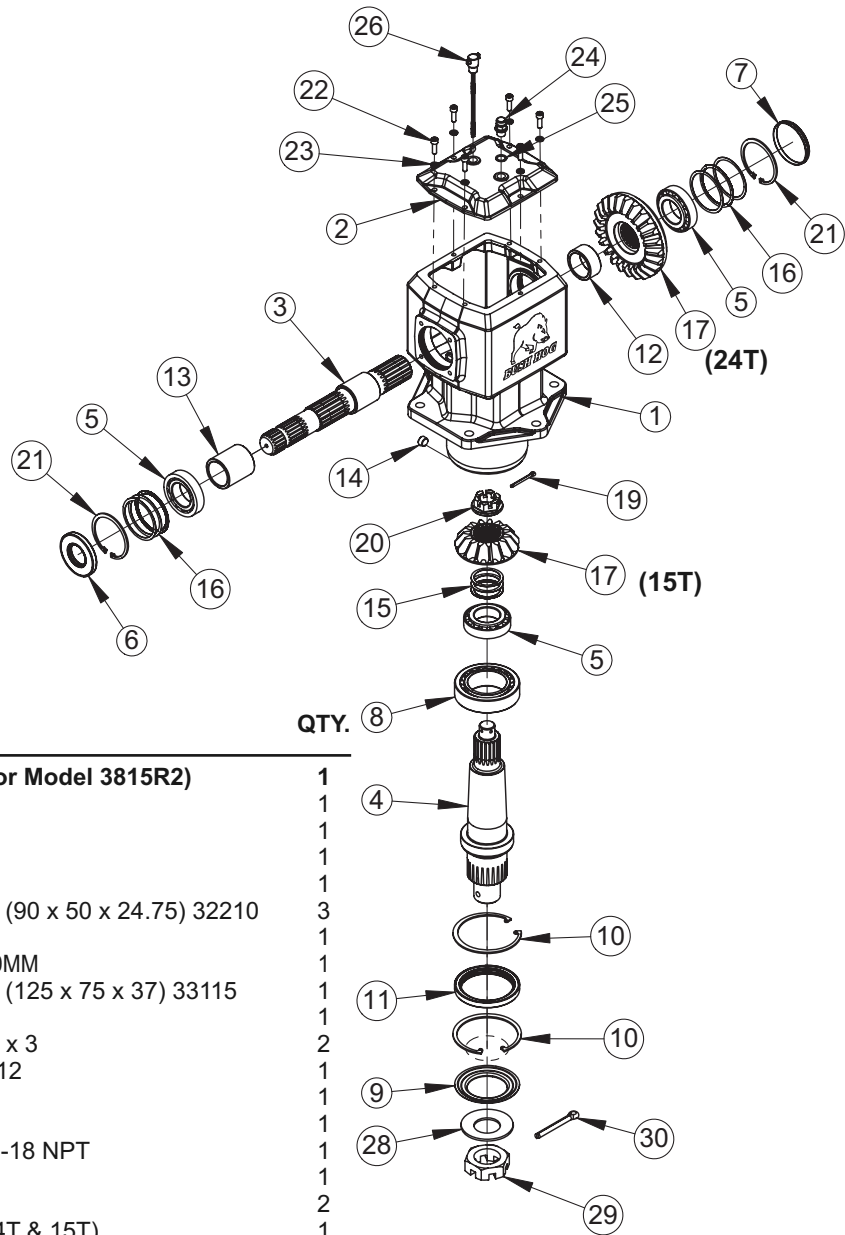

REF. NO.	PART NO.	DESCRIPTION	QTY.
	50071562BH	Gearbox Assembly (For Model 3815R2)	1
1	-----	Housing	1
2	00790887	Cap, Top	1
3	00790924	Shaft, Input	1
4	50069790	Shaft, Output	1
5	00779007	Bearing, Tapered Roller (90 x 50 x 24.75) 32210	3
6	00790889	Seal, Oil 90 x 44 x 10	1
7	50074090	Sight Window, Gearbox 90MM	1
8	00790928	Bearing, Tapered Roller (125 x 75 x 37) 33115	1
9	50069791	Protector, Seal	1
10	00790931	Ring, Internal Snap 125 x 3	2
11	00790930	Seal, Oil 101.6 x 125 x 12	1
12	00790932	Spacer, Small - Input	1
13	00790933	Spacer, Large - Input	1
14	13033	Plug, Socket Head, 3/8"-18 NPT	1
15	00790939	Kit, HD225 Shim	1
16	00790892	Kit, Input Shim	2
17	00790934	Kit, Gear 1:1.6 Ratio (24T & 15T)	1
19	70497	Cotter Pin, M5 x 50	1
20	00790937	Hex Nut, Slotted Flg, M30-2.0	1
21	00790891	Ring, Internal Snap, 90 x 3	2
22	00790896	Bolt, Socket Hd, M8 x 1.25 x 20	6
23	701611C	Lockwasher, M8	6
24	00790985	Plug, Vent, M16-1.5	1
25	00790983	Washer, Sealing, M16	1
26	4038612	Dipstick, Oil	1
28	50071362	Washer, Spring 2"	1
29	50071363	Hex Nut, Slotted Jam, 2"-12	1
30	50071364	Cotter Pin, 10MM x 100MM	1

**50071564BH - GEARBOX ASSY, EZ225B, RATIO 1:1.375, (1000 RPM)
LH WING - 13815R2**

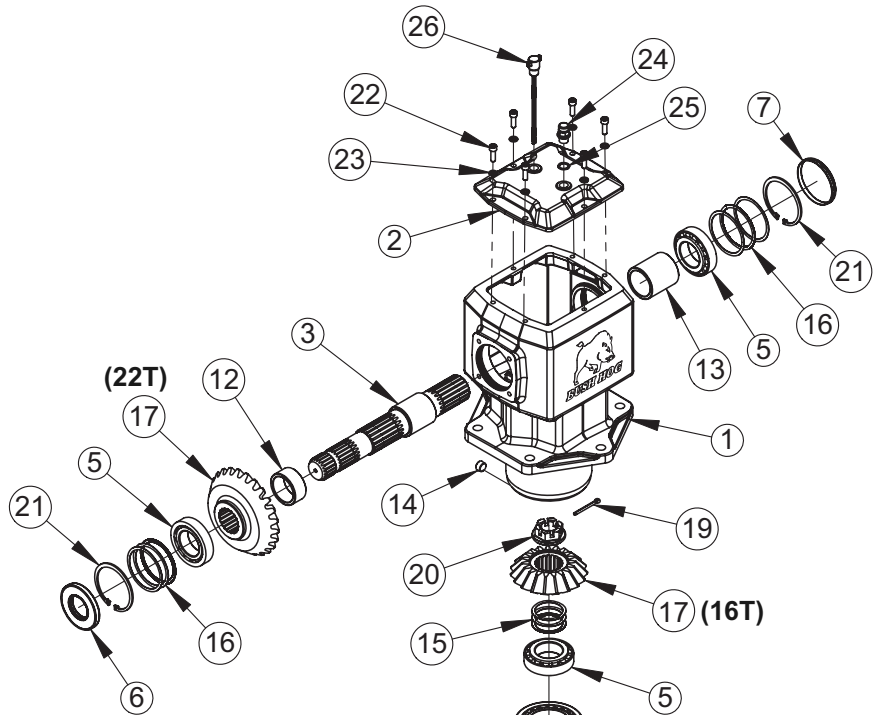

REF. NO.	PART NO.	DESCRIPTION	QTY.
	50071564BH	Gearbox Assembly (For Model 13815R2)	1
1	-----	Housing	1
2	00790887	Cap, Top	1
3	00790924	Shaft, Input	1
4	50069790	Shaft, Output	1
5	00779007	Bearing, Tapered Roller (90 x 50 x 24.75) 32210	3
6	00790889	Seal, Oil 90 x 44 x 10	1
7	50074090	Sight Window, Gearbox 90MM	1
8	00790928	Bearing, Tapered Roller (125 x 75 x 37) 33115	1
9	50069791	Protector, Seal	1
10	00790931	Ring, Internal Snap 125 x 3	2
11	00790930	Seal, Oil 101.6 x 125 x 12	1
12	00790932	Spacer, Small - Input	1
13	00790933	Spacer, Large - Input	1
14	13033	Plug, Socket Head, 3/8"-18 NPT	1
15	00790939	Kit, HD225 Shim	1
16	00790892	Kit, Input Shim	2
17	00790950	Kit, Gear 1:1.375 Ratio (22T & 16T)	1
19	70497	Cotter Pin, M5 x 50	1
20	00790937	Hex Nut, Slotted Flg, M30-2.0	1
21	00790891	Ring, Internal Snap, 90 x 3	2
22	00790896	Bolt, Socket Hd, M8 x 1.25 x 20	6
23	701611C	Lockwasher, M8	6
24	00790985	Plug, Vent, M16-1.5	1
25	00790983	Washer, Sealing, M16	1
26	4038612	Dipstick, Oil	1
28	50071362	Washer, Spring 2"	1
29	50071363	Hex Nut, Slotted Jam, 2"-12	1
30	50071364	Cotter Pin, 10MM x 100MM	1

**50071565BH - GEARBOX ASSY, EZ225B, RATIO 1:1.375 (1000 RPM)
RH WING - 13815R2**

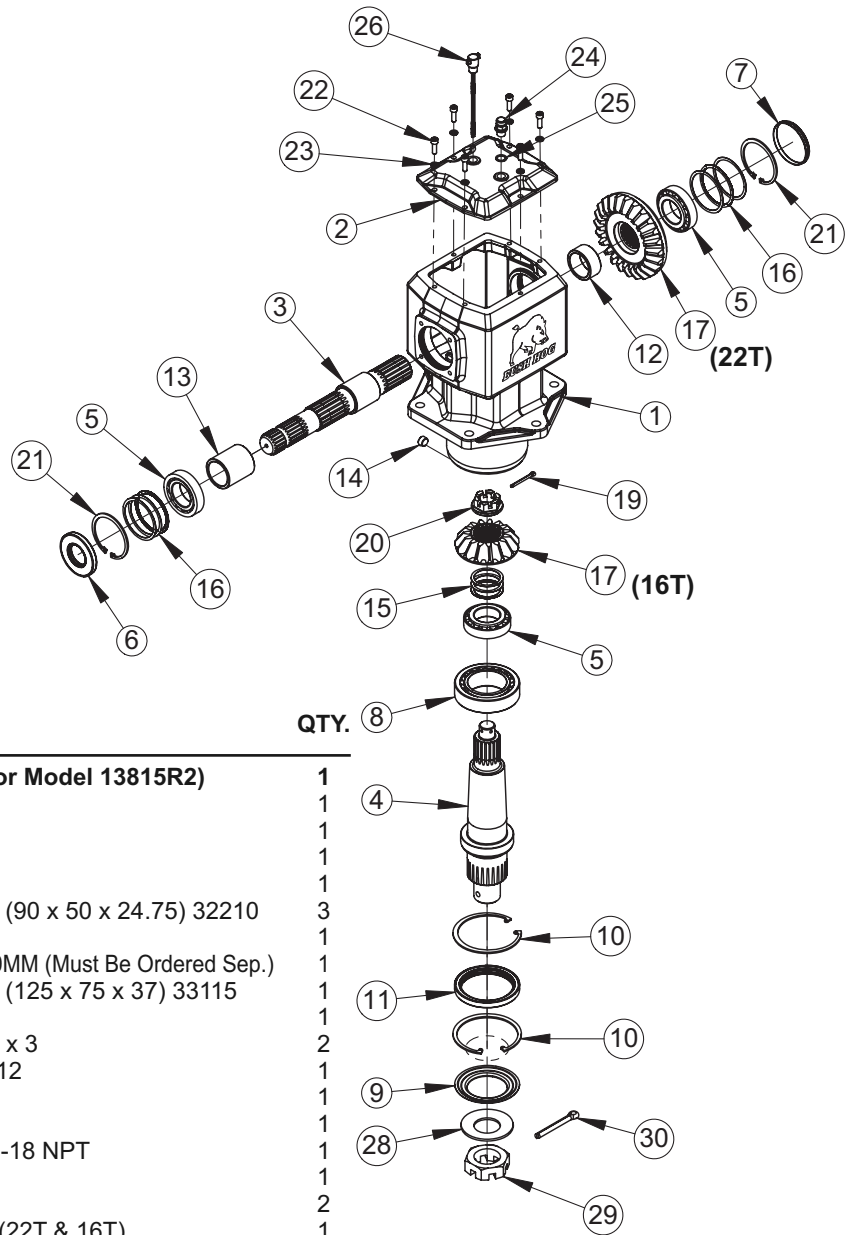

REF. NO.	PART NO.	DESCRIPTION	QTY.
	50071565BH	Gearbox Assembly (For Model 13815R2)	1
1	-----	Housing	1
2	00790887	Cap, Top	1
3	00790924	Shaft, Input	1
4	50069790	Shaft, Output	1
5	00779007	Bearing, Tapered Roller (90 x 50 x 24.75) 32210	3
6	00790889	Seal, Oil 90 x 44 x 10	1
7	50074090	Sight Window, Gearbox 90MM (Must Be Ordered Sep.)	1
8	00790928	Bearing, Tapered Roller (125 x 75 x 37) 33115	1
9	50069791	Protector, Seal	1
10	00790931	Ring, Internal Snap 125 x 3	2
11	00790930	Seal, Oil 101.6 x 125 x 12	1
12	00790932	Spacer, Small - Input	1
13	00790933	Spacer, Large - Input	1
14	13033	Plug, Socket Head, 3/8"-18 NPT	1
15	00790939	Kit, HD225 Shim	1
16	00790892	Kit, Input Shim	2
17	00790950	Kit, Gear 1:1.375 Ratio (22T & 16T)	1
19	70497	Cotter Pin, M5 x 50	1
20	00790937	Hex Nut, Slotted Flg, M30-2.0	1
21	00790891	Ring, Internal Snap, 90 x 3	2
22	00790896	Bolt, Socket Hd, M8 x 1.25 x 20	6
23	701611C	Lockwasher, M8	6
24	00790985	Plug, Vent, M16-1.5	1
25	00790983	Washer, Sealing, M16	1
26	4038612	Dipstick, Oil	1
28	50071362	Washer, Spring 2"	1
29	50071363	Hex Nut, Slotted Jam, 2"-12	1
30	50071364	Cotter Pin, 10MM x 100MM	1

50071111 DRIVESHAFT ASSEMBLY WITH CLUTCH

Wing Driveshaft – ASAE Size 5

Manufactured by Comer / EG

Used on 3815R2, 13815R2 & 3810R2, 13810R2

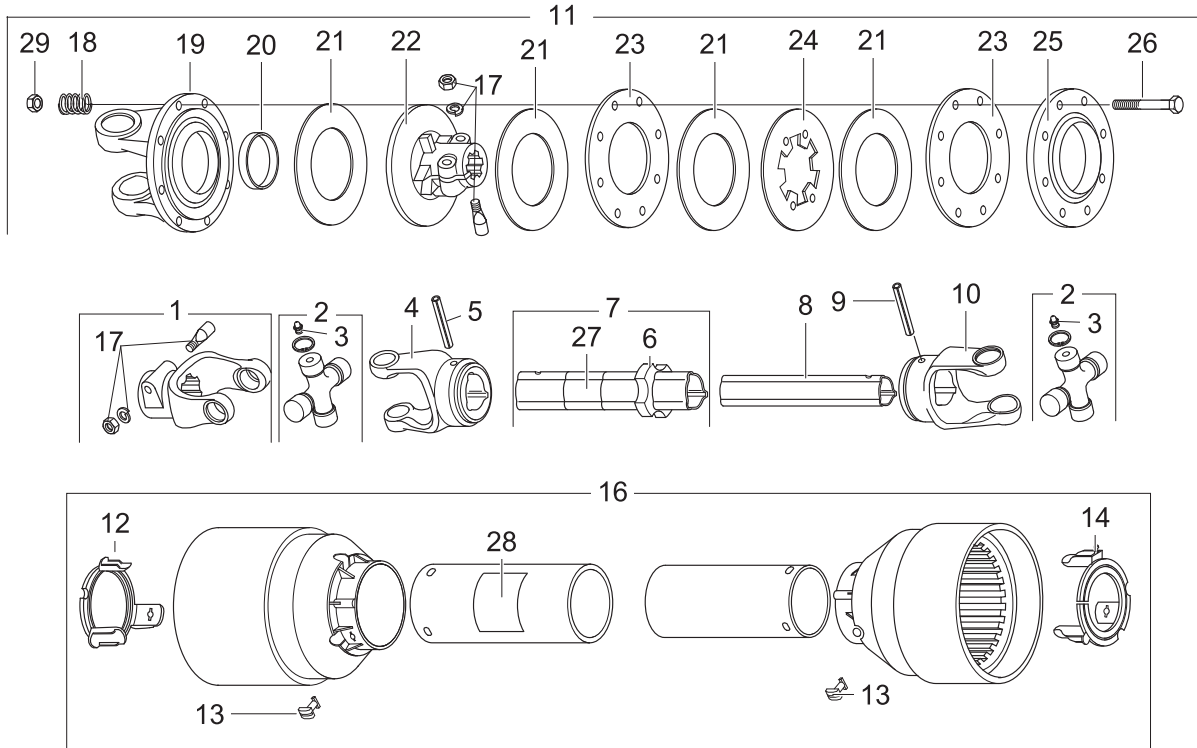

REF. NO.	PART NO.	DESCRIPTION	QTY.	REF. NO.	PART NO.	DESCRIPTION	QTY.
	50071111	Driveshaft Assembly	1	16	50072387	Guard Assy. Complete	1
1	76239BH	Yoke Assembly	1	17	76247	Tapered Pin Set	2
2	76998	Cross Journal Kit	2	18	76080	Spring	8
3	76335	Grease Fitting	2	19	76331	Flanged Yoke	1
4	78134	Outer Yoke	1	20	76082	Bushing	1
5	67108	Roll Pin Outer Yoke	1	21	76083	Lining Ring	4
6	76274	Bushing w/ Fitting	1	22	76458	Support	1
7	50072385	Outer Tube Assy	1	23	76085	Inner Plate	2
8	50072386	Inner Tube	1	24	76197	Intermediate Plate	1
9	67085	Roll Pin Inner Yoke	1	25	76086	Pressure Plate	1
10	67086	Inner Yoke	1	26	44159BH	Capscrew M10 x 1.5 x 100	8
11	50061008	Clutch Assy	1	27	78786	Danger Decal, Outer Tube	1
12	50056403	Retaing Collar Outer	1	28	78608	Danger Decal, Outer Shield	1
13	50056404	Bolt	6	29	44154BH	Hex Nut M10 x 1.5 C9	8
14	50056405	Retaining Collar Inner	1				

50058536 CENTER DRIVELINE ASSEMBLY
3815R2, 13815R2 & 3810R2, 13810R2

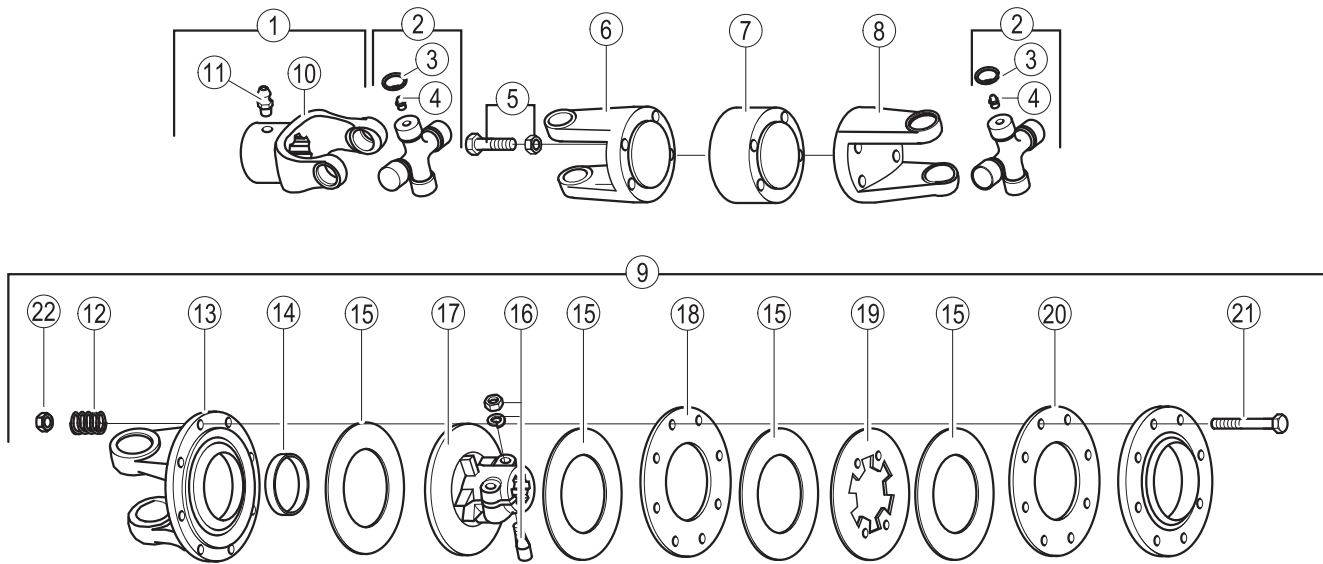

REF. NO.	PART NO.	DESCRIPTION	QTY.
	50058536	Center Driveline Assy.	1
1	76782	Yoke w/Grease Nipple	1
2	50060543	Cross Bearing Kit	2
3	-----	CirClip	8
4	76335	Grease Fitting	2
5	76965	Capscrew M12 x 1.25 x 90 Gr 12.9 & Locknut M12 x 1.25	4
6	76305	Flanged Yoke, Male	1
7	76306	Retaining Washer	1
8	76307	Flanged Yoke, Female	1
9	76456	Clutch Assembly	1
10	50061005	Yoke	1
11	63946	Grease Nipple	1
12	76080	Spring	8
13	76164	Flanged Yoke	1
14	76082	Bushing	1
15	76083	Lining Ring	4
16	76247	Tapered Pin Kit	1
17	76458	Clutch Support	1
18	76085	Inner Plate	2
19	76197	Intermediate Plate	1
20	76086	Pressure Plate	1
21	44159BH	Capscrew M10 x 1.5 x 100 Gr.8	8
22	44154BH	Locknut M10 x 1.5 C9	8

**50054670SP C.V. Driveshaft
(REPLACED BY 50074699SP DRIVESHAFT ASSEMBLY)**

Input : 1-3/4" – 20 Spline, ASAE Size 5

Manufactured by Comer / EG

13815R2 & 13810R2 (1000 RPM Models)

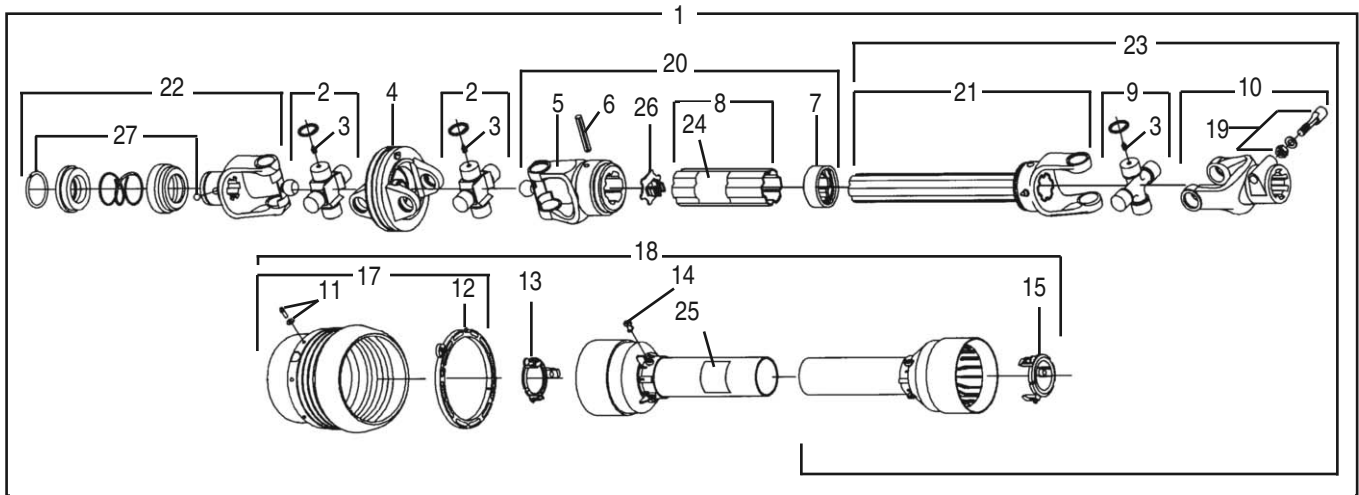

REF. NO.	PART NO.	DESCRIPTION	QTY.
1	50054670SP	Driveshaft Assembly	1
2	50056400	Cross Journal Set	2
3	76335	Grease Nipple	3
4	76357	Wide Angle Double Yoke	1
5	76896	Outer Yoke	1
6	67108	Roll Pin For Outer Tube	1
7	76897	Wiper	1
8	76903	Complete Outer Tube	1
9	50056401	Cross Journal Set	1
10	76239BH	Yoke Assembly 1-3/4" - 20 Spline	1
11	76362	Screw Kit	6
12	50056402	Bearing Ring	1
13	50056403	Guard Retaining Collar For Outer Tube	1
14	50056404	Bolt	6
15	50056405	Guard Retaining Collar For Inner Tube	1
17	50056406	Guard Cone Set	1
18	50056407	Complete Guard w/Instruction Manual	1
19	76247	Tapered Pin Set 1-3/4"	1
20	50056408	Female Tube w/Yoke & Lube System	1
21	50056409	Male Tube w/Yoke & Lube System	1
22	50056927	Complete Collar Yoke (Tractor)	1
23	50056413	Half Male Shaft w/Guarding	1
24	78786	Decal, Danger - Outer Tube	1
25	78608	Decal, Danger - Outer Guard Tube	1
26	76899	Plastic Cap	1
27	50017502	Kit Collar For Yoke 1-3/4"	1

50069764SP C.V. Driveshaft
Input : 1-3/8" – 6 Spline, ASAE Size 5
Manufactured by Comer / EG
3815R2 & 3810R2 (540 RPM Models)

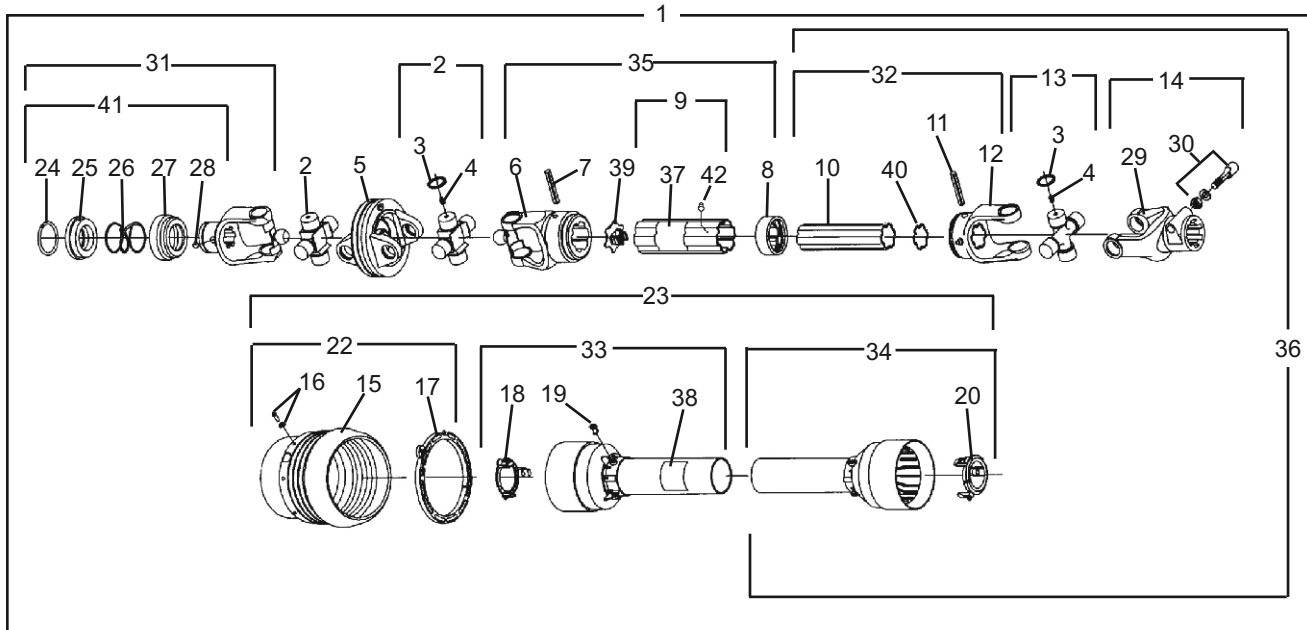

REF. NO.	PART NO.	DESCRIPTION	QTY.	REF. NO.	PART NO.	DESCRIPTION	QTY.
1	50069764SP	Driveshaft Assembly	1	22	50056406	Guard Cone Set	1
2	50056400	Cross Journal Set	2	23	50071245	Complete Guard w/Inst. Manual	1
3	-----	Circlip	12	24	-----	Outer Circlip	1
4	76335	Grease Nipple	3	25	-----	Sliding Sleeve Collar	1
5	76357	Wide Angle Double Yoke	1	26	-----	Spring	1
6	76896	Outer Yoke	1	27	-----	Fixed Sleeve	1
7	67108	Roll Pin - Outer & Inner Tube	1	28	-----	Ball, 1/2"	3
8	76897	Wiper	1	29	-----	Yoke (See Item 14)	1
9	50071242	Complete Outer Tube	1	30	76247	Tapered Pin Set 1-3/4"	1
10	50071243	Inner Tube	1	31	50017504	Yoke Assy. 1-3/8 - 6 Spline	1
11	67085	Roll Pin For Inner Tube	1	32	-----	Male Tube w/Yoke	1
12	50071244	Inner Yoke	1	33	-----	Half Female Guarding w/Label	1
13	50056401	Cross Journal Set	1	34	-----	Half Male Guarding (See Item 23)	1
14	76239BH	Complete Yoke	1	35	-----	Female Shaft (See Item 1)	1
15	-----	Guard Cone	1	36	50071246	Half Male Shaft w/Guarding	1
16	76362	Screw Kit	6	37	78786	Decal, Danger - Outer Tube	1
17	50056402	Bearing Ring	1	38	78608	Decal, Danger - Outer Guard Tube	1
18	50056403	Guard Ret. Collar - Outer Tube	1	39	76899	Plastic Cap - Outer Tube	1
19	50056404	Bolt	6	40	50071247	Plastic Cap - Inner Tube	1
20	50056405	Guard Ret. Collar - Inner Tube	1	41	50017480	Kit Collar For Yoke 1-3/8"	1
				42	50075570	Grease Fitting	1

50069765SP C.V. Driveshaft
Input : 1-3/8" – 21 Spline, ASAE Size 5
Manufactured by Comer / EG
13815R2 & 13810R2 (1000 RPM Models)

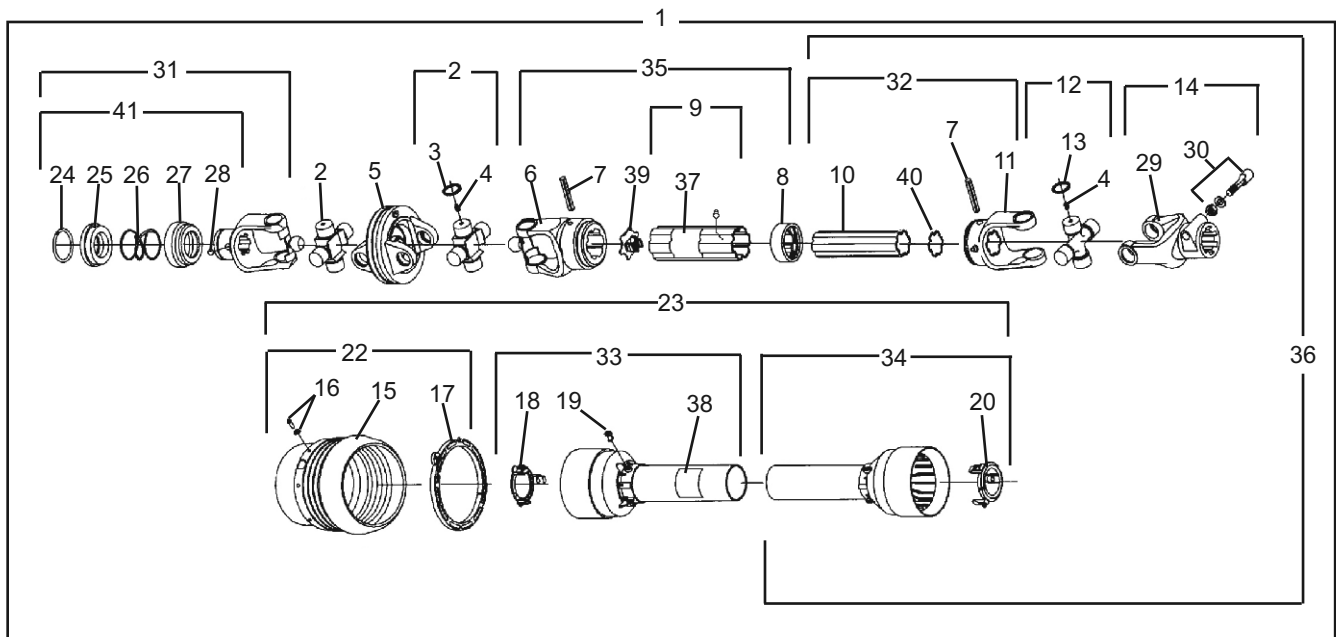

REF. NO.	PART NO.	DESCRIPTION	QTY.	REF. NO.	PART NO.	DESCRIPTION	QTY.
1	50069765SP	Driveshaft Assembly	1	22	50056419	Guard Cone Set	1
2	50056414	Cross Journal Set	2	23	50071251	Complete Guard w/Inst. Manual	1
3	-----	Circlip (See Item 2)	8	24	-----	Outer Circlip (See Item 31 or 41)	1
4	76335	Grease Nipple	3	25	-----	Sliding Sleeve Collar (See Item 31 or 41)	1
5	76421	Wide Angle Double Yoke	1	26	-----	Spring (See Item 31 or 41)	1
6	76893	Outer Yoke	1	27	-----	Fixed Sleeve (See Item 31 or 41)	1
7	66866	Roll Pin - Outer & Inner Tube	2	28	-----	Ball, 1/2" (See Item 31 or 41)	3
8	76894	Wiper	1	29	-----	Yoke (See Item 14)	1
9	50071248	Complete Outer Tube	1	30	76247	Tapered Pin Set 1-3/4"	1
10	50071249	Inner Tube	1	31	50017482	Yoke Assy 1-3/8" - 21 Spline	1
11	50071250	Inner Yoke	1	32	-----	Male Tube w/Yoke (See Item 36)	1
12	50056411	Cross Journal Set	1	33	-----	Half Female Guarding (See Item 23)	1
13	-----	Circlip (See Item 12)	4	34	-----	Half Male Guarding (See Item 23)	1
14	76422	Complete Yoke	1	35	-----	Female Shaft (See Item 1)	1
15	-----	Guard Cone (See item 22)	1	36	50071252	Half Male Shaft w/Guarding	1
16	76362	Screw Kit	6	37	78786	Decal, Danger - Outer Tube	1
17	50056416	Bearing Ring	1	38	78608	Decal, Danger - Outer Guard Tube	1
18	50056417	Guard Ret. Collar - Outer Tube	1	39	76892	Plastic Cap - Outer Tube	1
19	50056404	Bolt	6	40	50071253	Plastic Cap - Inner Tube	1
20	50056418	Guard Ret. Collar - Inner Tube	1	41	50017480	Kit Collar For Yoke 1-3/8"	1

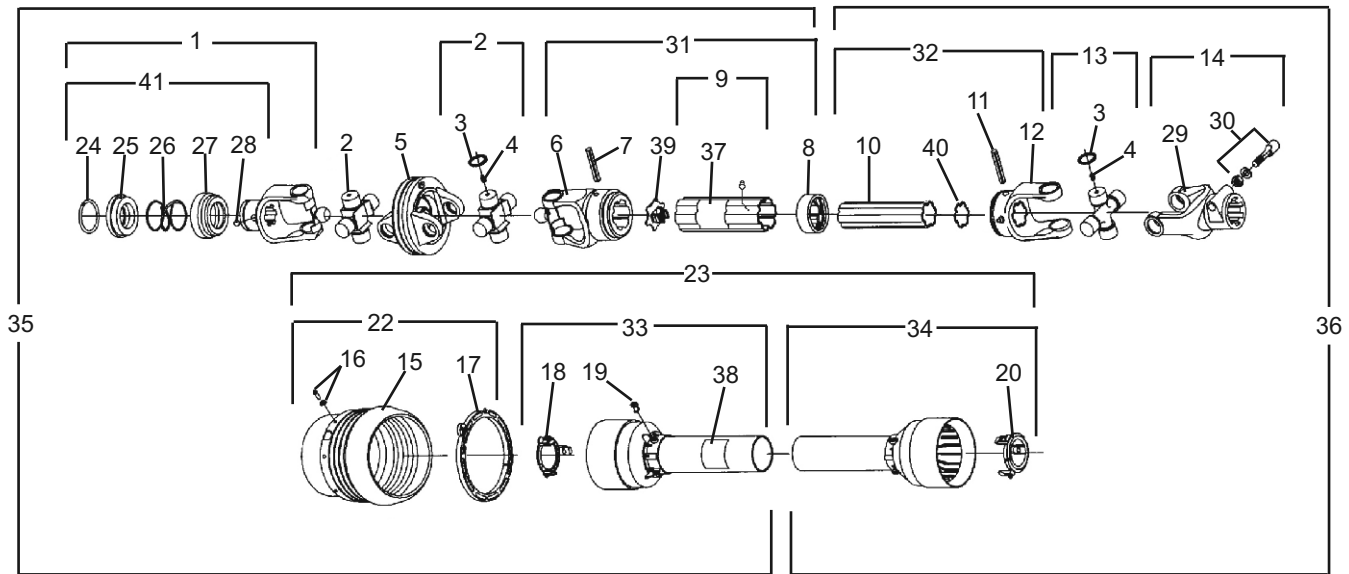

50074699SP C.V. Driveshaft
(REPLACES 50054670SP DRIVESHAFT)
Input : 1-3/4" – 20 Spline, ASAE Size 5
Manufactured by Comer / EG
13815R3 & 13810R3 (1000 RPM Models)

REF. NO.	PART NO.	DESCRIPTION	QTY.	REF. NO.	PART NO.	DESCRIPTION	QTY.
	50074699SP	Assembly, Driveline	1	22	50075192	Guard Cone Set	1
1	50056927	Complete Yoke	1	23	50075193	Complete Guard w/Inst. Manual	1
2	50056400	Cross Journal Set	2	24	-----	Outer Circlip	1
3	-----	Circlip	12	25	-----	Sliding Sleeve Collar	1
4	76335	Grease Nipple	3	26	-----	Spring	1
5	76357	Wide Angle Double Yoke	1	27	-----	Fixed Sleeve	1
6	76896	Outer Yoke	1	28	-----	Ball, 1/2"	3
7	67108	Roll Pin - Outer & Inner Tube	1	29	-----	Yoke	1
8	76897	Wiper	1	30	76247	Tapered Pin Set 1-3/4"	1
9	50075190	Complete Outer Tube	1	31	-----	Female Tube w/Yoke	1
10	50075191	Inner Tube	1	32	-----	Male Tube w/Yoke	1
11	67085	Roll Pin For Inner Tube	1	33	-----	Half Female Guarding w/Label	1
12	50071244	Inner Yoke	1	34	-----	Half Male Guarding	1
13	50056411	Cross Journal Set	1	35	-----	Half Female Shaft w/Guarding	1
14	76239BH	Complete Yoke	1	36	-----	Half Male Shaft w/Guarding	1
15	-----	Guard Cone	1	37	78786	Decal, Danger - Outer Tube	1
16	76362	Screw Kit	6	38	78608	Decal, Danger - Outer Guard Tube	1
17	50056402	Bearing Ring	1	39	76899	Plastic Cap - Outer Tube	1
18	50056403	Guard Ret. Collar - Outer Tube	1	40	50071247	Plastic Cap - Inner Tube	1
19	50056404	Bolt	6	41	50017502	Kit Collar For Yoke 1-3/4"	1
20	50056405	Guard Ret. Collar - Inner Tube	1				

TONGUE, LEVELING ROD & RELATED PARTS FOR 3815R2 & 3810R2, 13815R2 & 13810R2 MODELS

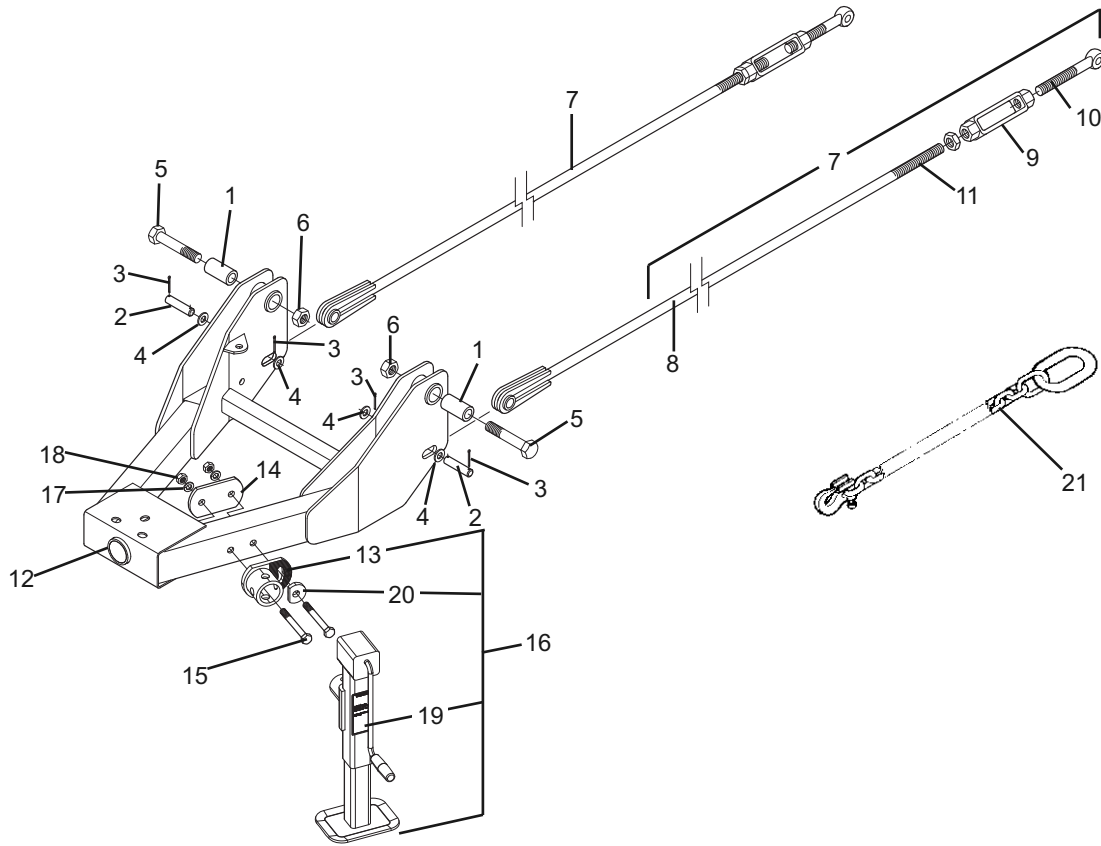

REF. NO.	PART NO.	DESCRIPTION	QTY.
1	50054456	Sleeve Bushing	2
2	50054389	Clevis Pin	2
3	20167	Cotter Pin, 3/16" x 2"	4
4	20376	Flatwasher, 1" SAE	4
5	19137	Capscrew, 1" x 5-1/2"	2
6	9163200	Locknut, 1"	2
7	50054463	Leveling Rod Assy	2
8	50054461	Rod Weldment	1
9	53053BH	Turnbuckle	1
10	60636	Turnbuckle End	1
11	15612	Hex Jam Nut	1
12	50069248	Tongue Weldment	1
13	00779360	Bracket, Jack Weldment	1
14	50069926	Mount Pad	1
15	44064BH	Capscrew, 3/4" x 5"	2
16	00779350	Jackstand Assy (Includes Items 13, 19 & 20)	1
17	146	Lockwasher, 3/4"	2
18	19517	Hex Nut, 3/4"	2
19	D482	Decal, Warning	1
20	00779361	Washer, Jack	1
21	91074	Safety Tow Chain	1

DRIVELINE HOLDER ASSEMBLY
For 3815R2 & 3810R2, 13815R2 & 13810R2 Models

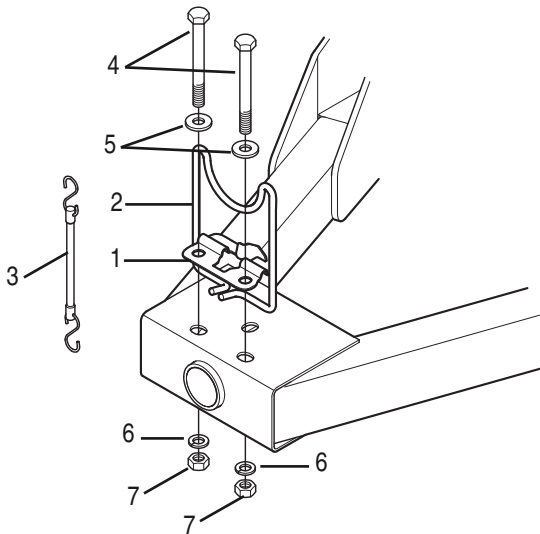

REF. NO.	PART NO.	DESCRIPTION	QTY.
1	50054710	Mounting Bracket Weld.	1
2	50054711	Formed Driveline Holder	1
3	50060002	Tie-Down Strap	1
4	20923	Capscrew, 5/8" x 6"	2
5	20748	Flatwasher, 5/8" SAE	2
6	19486	Lockwasher, 5/8"	2
7	15563	Hex Nut, 5/8"	2
8	-----	Instruction Sheet (50080870)	1

SWIVEL PIVOT HITCH ASSEMBLY
For 3815R2 & 3810R2, 13815R2 & 13810R2 Models

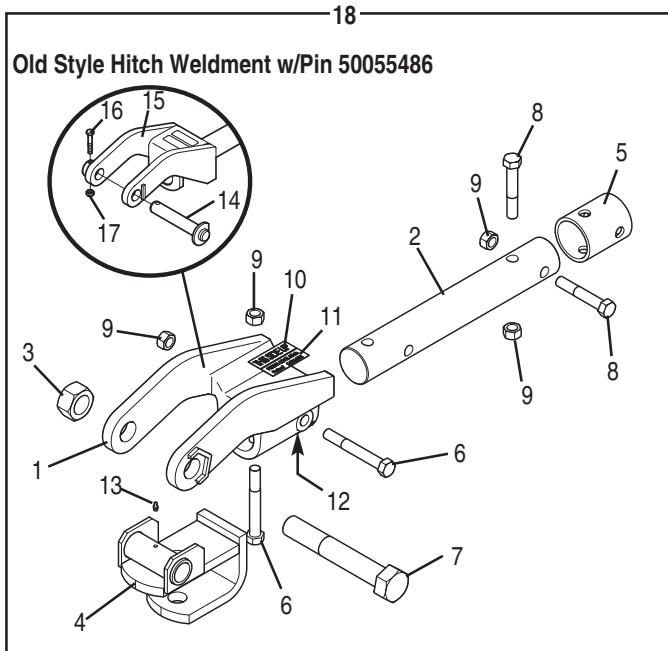

REF. NO.	PART NO.	QTY.	DESCRIPTION
1	50074196	1	Hitch w/Decals
2	50074187	1	Shaft
3	15521	1	Locknut, 1-1/4" Gr. C
4	50080681	1	Clevis Assembly
5	86356	1	Collar
6	-----	2	Capscrew, 5/8" x 4-3/4" Gr. 5
7	45324	1	Capscrew, 1-1/4" x 8" Gr. 5
8	44168BH	2	Capscrew, 5/8" x 3-3/4" Gr. 5
9	15598BH	4	Locknut, 5/8"
10	50035874	1	Decal, Direction
11	97692	1	Decal, Patent
12	50045639	1	Decal, Direction
13	150033	1	Grease Fitting
14	50055486	1	Pin Weldment
15	50055447	1	Hitch Weldment
16	20048	1	Capscrew, 3/8" x 2-1/4" Gr. 5
17	9131200	1	Locknut, 3/8"
18	50054505SP	1	Swivel Pivot Hitch Assy

50072803 - BALL HITCH ASSEMBLY
For 3815R2 & 3810R2, 13815R2 & 13810R2 Models

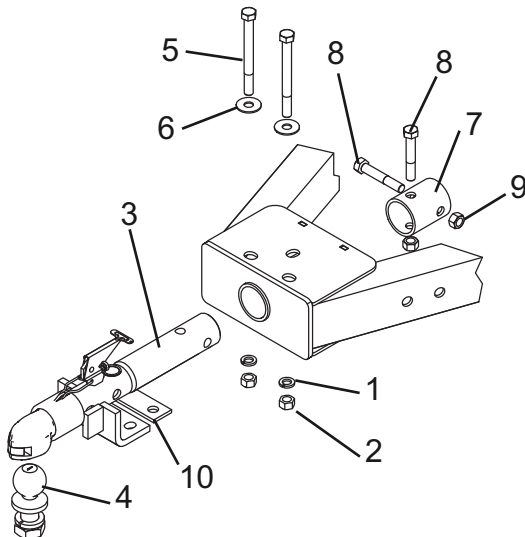

REF. NO.	PART NO.	DESCRIPTION	QTY.
1	19486	Lockwasher 5/8"	2
2	15563	Hex Nut 5/8"	2
3	50072805	Ball Hitch Weldment	1
4	50068048	Ball Assy. 2-5/16"	1
5	20294	Capscrew 5/8" x 6-1/2" Gr.5	2
6	15925	Flatwasher 5/8"	2
7	86356	Collar	1
8	44120BH	Capscrew 5/8" x 3-3/4" NF Gr.5	2
9	15516	Locknut 5/8" NF, Gr. C	2
10	50072808	Bracket, Mount Spacer	1

EZ MOUNT - CV DRIVELINE PARKING STAND

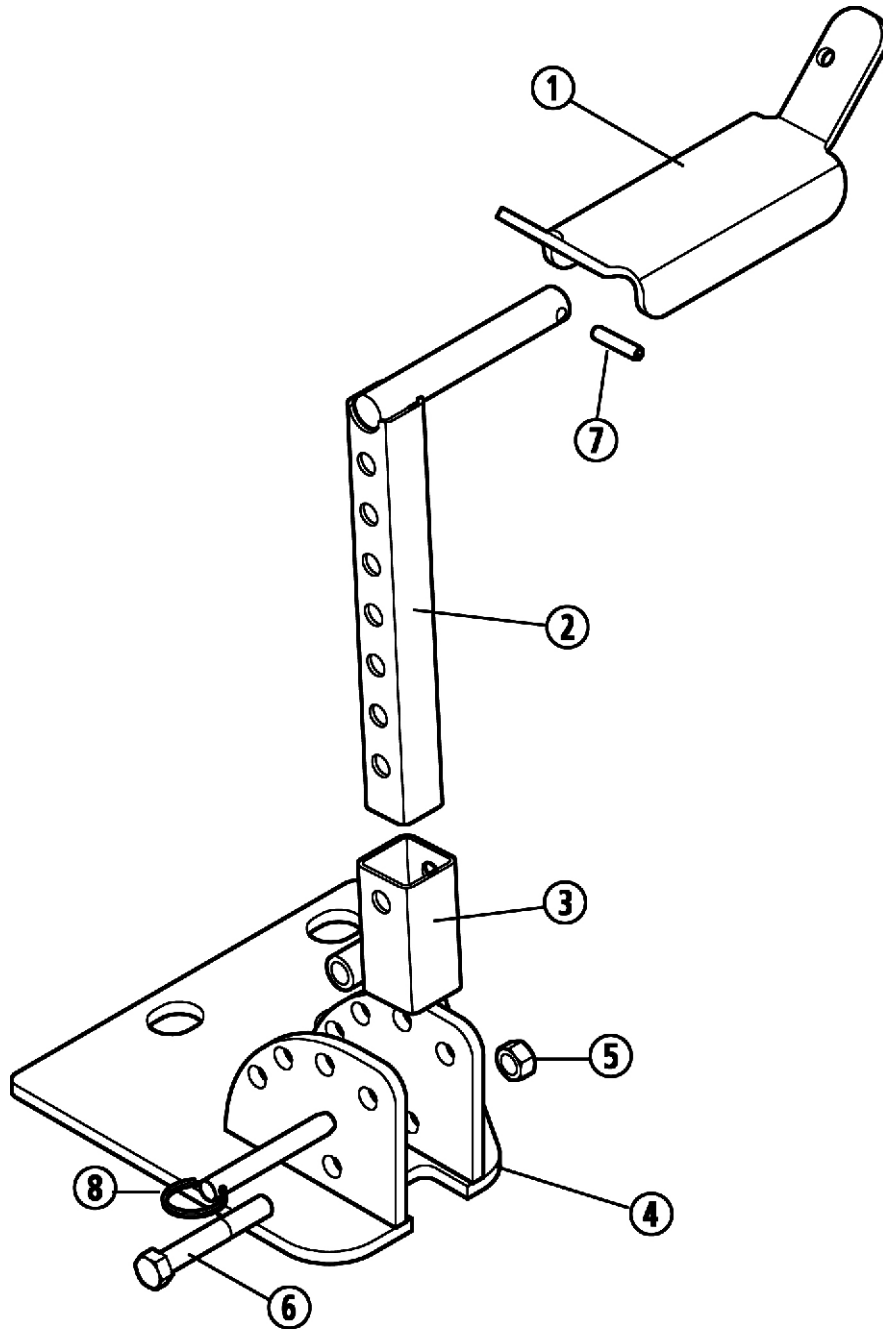

REF. NO.	PART NO.	DESCRIPTION	QTY.
	50077430	EZ Mount Driveline Holder Assy.	1
1	50077435	Saddle Weldment	1
2	50077434	Adjustment Tube Weldment	1
3	50077433	Pivot Mount	1
4	50077432	Base Weldment	1
5	20360	Locknut 3/8"	1
6	20224	Bolt 3/8" x 2-1/2" Gr.5	1
7	44533	Roll Pin 7/32" x 1"	1
8	50077436	Quick Pin	1

AXLES & RELATED PARTS FOR 3815R2 & 3810R2, 13815R2 & 13810R2 MODELS

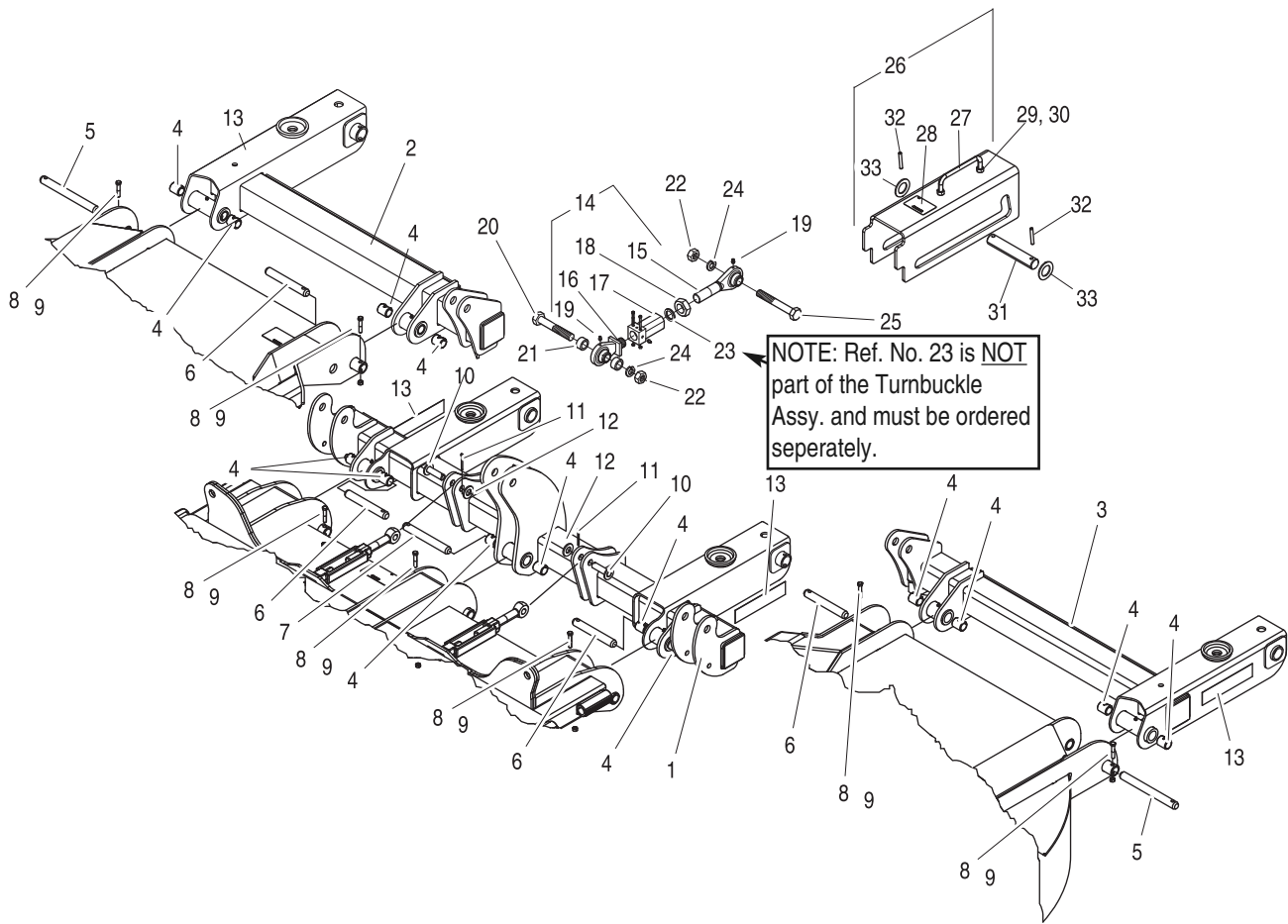

REF. NO.	PART NO.	DESCRIPTION	QTY.
1	50070908	Center Axle w/Wear Bearings	1
2	50070909	Wing Axle w/Wear Bushings R.H.	1
3	50070910	Wing Axle w/Wear Bushings L.H.	1
4	50021149	Wear Bushing	14
5	50029760	Pin, Pivot, 1" x 9.88"	2
6	50054388	Pin, Pivot, 1" x 7.25"	4
7	50054387	Pin, Pivot, 1" x 8"	1
8	1161220	Capscrew, 3/8" x 2" Gr. 5	7
9	20363	Locknut, 3/8"	7
10	14-32-49	Clevis Pin	2
11	20167	Cotter Pin, 3/16" x 2"	2
12	15922	Flatwasher, 7/8" SAE	2
13	50031212	Reflector, Amber	4
14	50052742	Turnbuckle Swivel Assy (15-19)	2
15	50052745	Rod Eye, Threaded	2
16	50052744	Rod Eye, Swivel	2
17	50052743	Turnbuckle Body	2

REF. NO.	PART NO.	DESCRIPTION	QTY.
18	50052746	Locknut, 1-1/4"	2
19	449BH	Grease Fitting	6
20	19137	Capscrew, 1" x 5-1/2" Gr. 5	2
21	50052732	Spacer, .75"	4
22	9163200	Locknut, 1"	2
23	50038405	Nord-Lockwasher, 1-1/4"	2
24	15821	Lockwasher, 1"	4
25	20547BH	Capscrew, 1" x 4-1/2" Gr. 5	2
26	50069408	Transport Lockout Assy	1
27	50027637	U-Bolt	1
28	D544	Decal, Important	1
29	45073	Hex Nut, 3/8" YZ	2
30	45105BH	Locknut, 3/8" YZ	2
31	50069413	Cylinder Pin, 5-5/8" Lg.	1
32	20325	Roll Pin, 1/4" x 1-3/4"	2
33	45057BH	Flatwasher, 1"	2

**AXLE ARMS & RELATED PARTS
SINGLE & DUAL SPINDLE
FOR 3815R2 & 3810R2, 13815R2 & 13810R2 MODELS**

**50073178 RH Single Spindle Axle Assembly
50073179 LH Single Spindle Axle Assembly
50073180 Dual Spindle Axle Assembly**

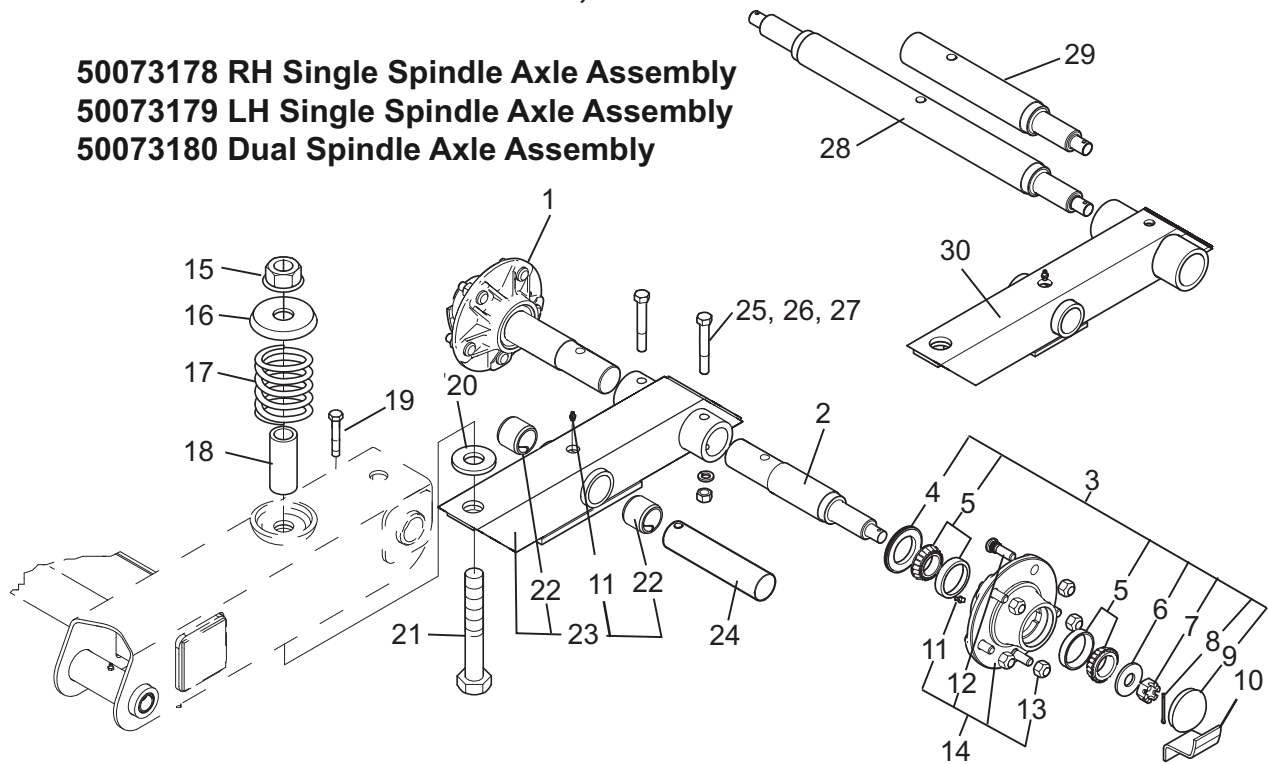

REF. NO.	PART NO.	DESCRIPTION	QTY.	NOTES
1	50073131	Spindle and Hub Assembly for Dual Wheel	2	(New Style)
	50073131	Spindle and Hub Assembly for Single Wheel	1	(New Style)
2	50073119	Spindle	1	(New Style)
3	50035756	Bearing Repair Kit, Hub	1	
4	7967	Seal, Grease	1	
5	50076BH	Bearing, Roller Cone	2	
6	15920	Washer, 3/4" SAE	1	
7	120BH	Nut, Slotted 3/4" UNF	1	
8	15973	Pin, Cotter 1/8" x 1-1/2"	1	
9	14-6-243	Cap, Grease	1	
10	00779390	Retainer, Hub Cap	2	
11	449BH	Grease Fitting	2	
12	15445	Lug Bolt	5	
13	15515BH	Lug Nut	5	
14	50035740	Hub Assembly	1	
15	44524BH	Locknut 1" Flanged	1	
16	91152	Cup, Spring	1	
17	50070462	Spring, Coil	1	
18	50070560	Stop, Spring	1	
19	20224	Capscrew 3/8" x 2-1/2" Gr.5	1	
20	91261	Cushion, Rubber	1	
21	20860	Capscrew 1" x 7-1/2" Gr.5	1	
22	50028543	Bushings, Spring 1-1/2"	2	
23	50073133	Tube Assembly	1	
24	50028461	Pin, Pivot	1	
25	20071	Capscrew 1/2" x 4" Gr. 5	1	
26	15806	Lockwasher 1/2"	1	
27	15554	Locknut 1/2"	1	
28	50035750	Dual Spindle	1	(OLD STYLE)
29	50035749	Single Spindle	1	(OLD STYLE)
30	50028533	Axle Tube Assembly	1	(OLD STYLE)

TANDEM AXLE ASSEMBLY (EARLY STYLE) FOR 3815R2 & 3810R2, 13815R2 & 13810R2 MODELS

You must first determine which version of Tandem Axle Assembly is on your machine before ordering Items 10, 11, 12.
See NOTE to determine which version is used.
IMPORTANT: Do Not mix parts from New Style to Old Style or Old Style to New Style.

NOTE: IF THIS TAB IS TURNED UPWARD AS SHOWN THIS IS A EARLY STYLE TANDEM AXLE ASSEMBLY.

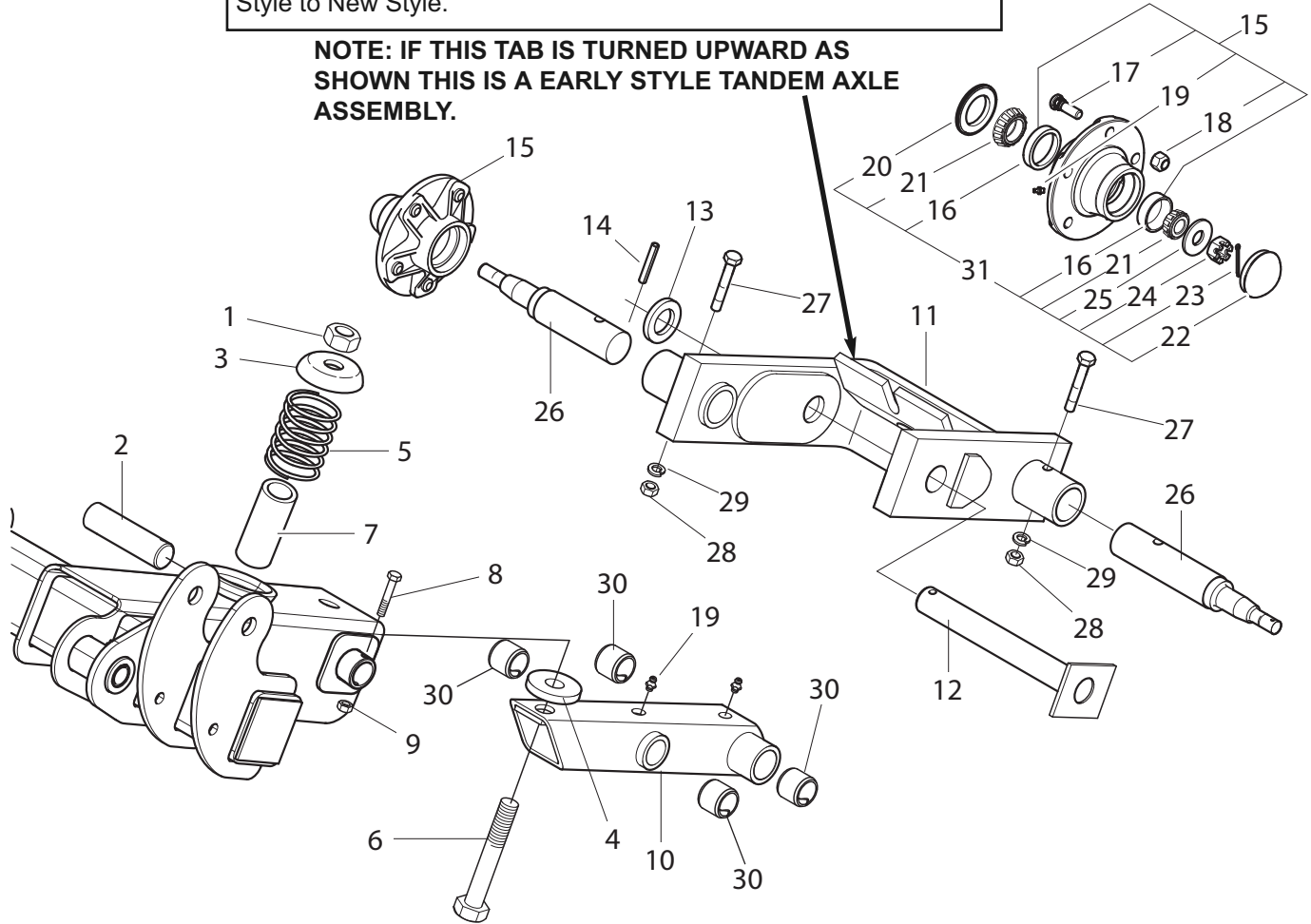

REF. NO.	PART NO.	DESCRIPTION	QTY.	REF. NO.	PART NO.	DESCRIPTION	QTY.
1	44524BH	Locknut, 1" Flanged	4	15	50035740	Hub Assembly	2
2	50028461	Pin, Pivot, 1.50" x 7.50"	4	16	14-6-197	Bearing Cup	4
3	91152	Spring Cup	4	17	15445	Lug Bolt	10
4	91261	Rubber Cushion	4	18	15515BH	Lug Nut	10
5	50070462	Spring, Coil	4	19	449BH	Grease Fitting	4
6	20860	Capscrew, 1" x 7-1/2"	4	20	7967	Seal	2
7	50070560	Spring Stop	4	21	50076BH	Bearing Cone, Inner	4
8	20224	Capscrew, 3/8" x 2-1/2" Gr. 5	4	22	14-6-243	Hub Cap	2
9	20363	Locknut, 3/8"	4	23	296	Cotter Pin, 1/8" x 1-1/2"	2
	50035752	Tandem Axle Assy L.H. (Shown)	1	24	120BH	Nut, Slotted, 3/4" NF	2
	50035753	Tandem Axle Assy R.H.	1	25	15920	Flatwasher, 3/4" SAE	2
10	50031928	Tube Assy w/Grease Fittings	1	26	50041170	Spindle, 9.82" (Short)	2
11	50032478	Spindle Weldment L.H. (Shown)	1	27	20779	Capscrew, 1/2" x 3-1/2"	2
	50032477	Spindle Weldment R.H.	1	28	15554	Locknut, 1/2"	2
12	50032483	Pin Weldment	1	29	15806	Lockwasher, 1/2"	2
13	15924	Flatwasher, 1-1/2"	1	30	50028543	Spring Bushing	4
14	53065	Spiral Pin, 3/8" x 2-1/2"	1	31	50035756	Bearing Repair Kit	1

TANDEM AXLE ASSEMBLY (CURRENT STYLE) FOR 3815R2 & 3810R2, 13815R2 & 13810R2 MODELS

You must first determine which version of Tandem Axle Assembly is on your machine before ordering Items 10, 11, 12.
See NOTE to determine which version is used.
IMPORTANT: Do Not mix parts from New Style to Old Style or Old Style to New Style.

NOTE: IF THIS TAB IS TURNED DOWN AS SHOWN THIS IS A CURRENT STYLE TANDEM AXLE ASSEMBLY.

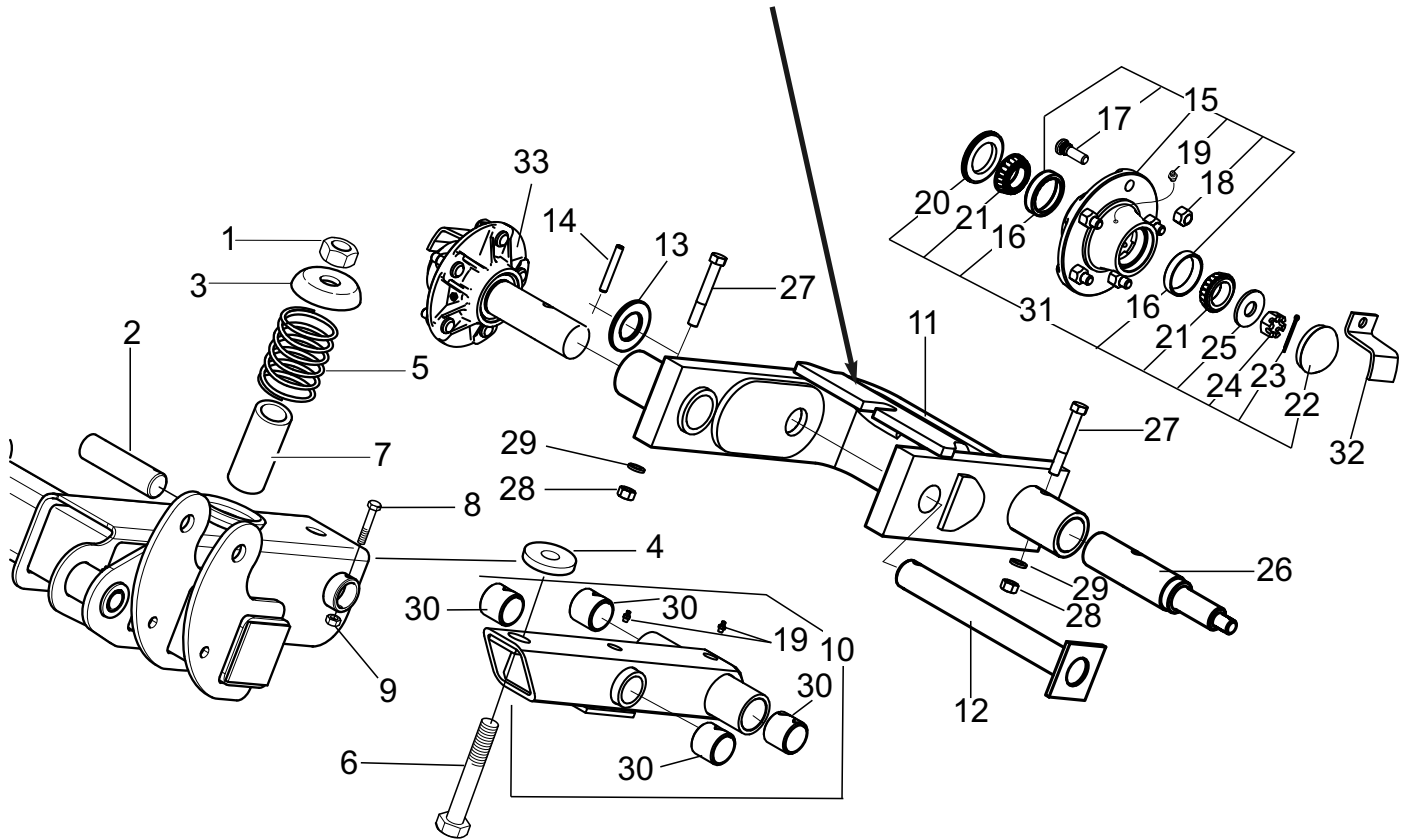

REF. NO.	PART NO.	DESCRIPTION	QTY.	REF. NO.	PART NO.	DESCRIPTION	QTY.
1	44524BH	Locknut, 1" Flanged	4	16	14-6-197	Bearing Cup	4
2	50028461	Pin, Pivot, 1.50" x 7.50"	4	17	15445	Lug Bolt	10
3	91152	Spring Cup	4	18	15515BH	Lug Nut	10
4	91261	Rubber Cushion	4	19	449BH	Grease Fitting	4
5	50070462	Spring, Coil	4	20	7967	Seal	2
6	20860	Capscrew, 1" x 7-1/2"	4	21	50076BH	Bearing Cone, Inner	4
7	50070560	Spring Stop	4	22	14-6-243	Hub Cap	2
8	20224	Capscrew, 3/8" x 2-1/2" Gr. 5	4	23	296	Cotter Pin, 1/8" x 1-1/2"	2
9	20363	Locknut, 3/8"	4	24	120BH	Nut, Slotted, 3/4" NF	2
	50076582	Tandem Axle Assy L.H. (Shown)	1	25	15920	Flatwasher, 3/4" SAE	2
	50076583	Tandem Axle Assy R.H.	1	26	50041170	Spindle, 9.82" (Short)	2
10	50076570	Tube Assy w/Grease Fittings	1	27	20779	Capscrew, 1/2" x 3-1/2"	2
11	50076574	Spindle Weldment L.H. (Shown)	1	28	15554	Locknut, 1/2"	2
	50076575	Spindle Weldment R.H.	1	29	15806	Lockwasher, 1/2"	2
12	50076566	Pin Weldment	1	30	50028543	Spring Bushing	4
13	15924	Flatwasher, 1-1/2"	1	31	50035756	Bearing Repair Kit	1
14	53065	Spiral Pin, 3/8" x 2-1/2"	1	32	00779390	Hub Cap Retainer	2
15	50035740	Hub Assembly	2	33	50073145	Spindle & Hub Assy.	2

WHEEL AND TIRE ASSEMBLIES
Models: 3815R2 & 3810R2, 13815R2 & 13810R2

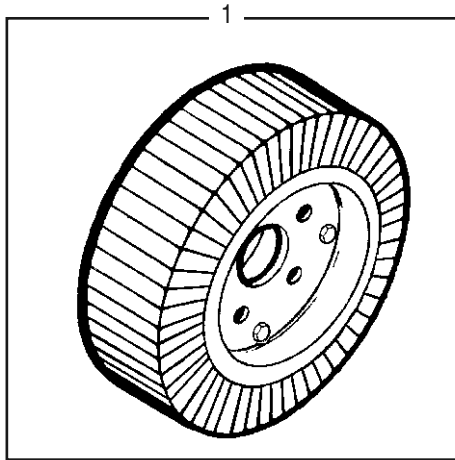

294SP SOLID TIRE ASSEMBLY
20" Diameter

REF. NO.	PART NO.	DESCRIPTION	QTY.
1	294SP	Solid Tire Assembly	1

50075401SP SEGMENTED TIRE ASSY.
25" Diameter

REF. NO.	PART NO.	DESCRIPTION	QTY.
1	50075401SP	Segmented Tire Assembly	1

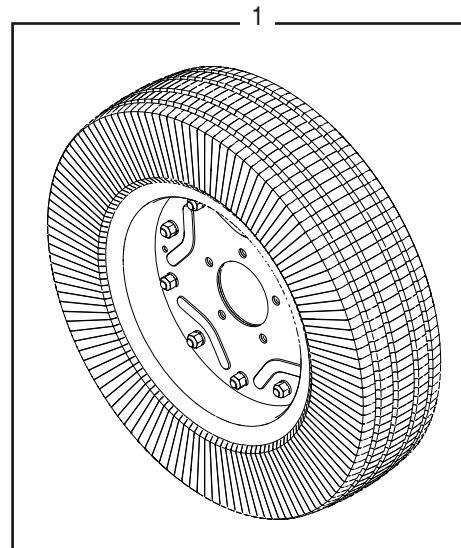

50072403SP AIR FILLED AIRPLANE TIRE ASSY.
24Ply 27.75" x 8.75" - 14.5"

REF. NO.	PART NO.	DESCRIPTION	QTY.
1	50072403SP	Air Filled Tire Assembly 27.75" x 8.75" -14.5"	1

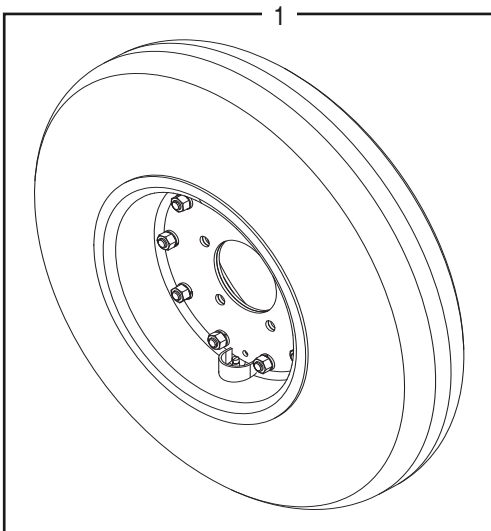

WHEEL AND TIRE ASSEMBLIES
Models: 3815R2 & 3810R2, 13815R2 & 13810R2

50050727SP AIRPLANE TIRE ASSEMBLY

REF. NO.	PART NO.	DESCRIPTION	QTY.
1	50051233BH	Tire 29 x 9.0 - 15/16 Ply	1
2	50051234	Tube 9 x 15	1
3	50073233	Wheel Flange Set	1
4	20054	Capscrew, 1/2" x 1" Gr. 5	10
5	15804	Lockwasher, 1/2"	10
6	15508	Hex Nut, 1/2"	10
7	50050727SP	Tire Assembly	1

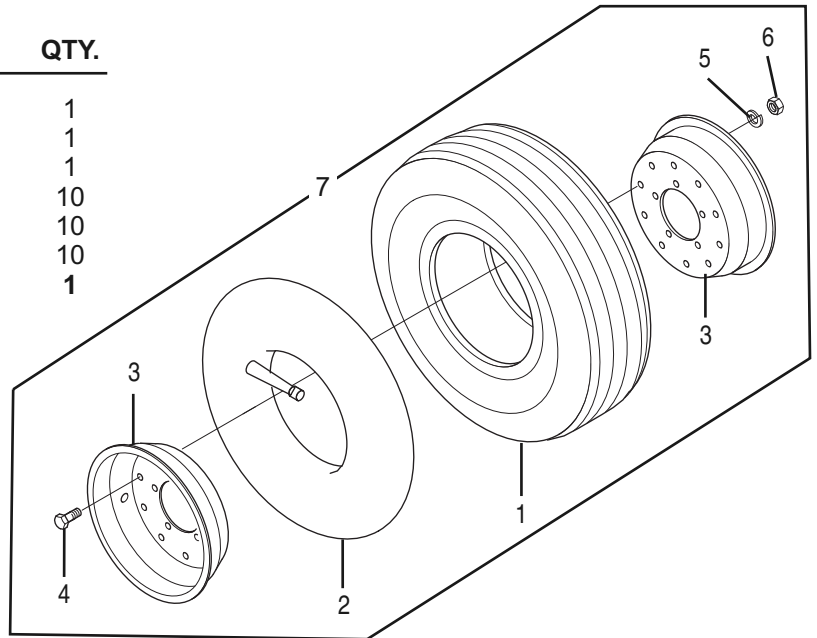

5007775SP FOAM FILLED AIRPLANE TIRE ASSY.
25" x 7" - 18"

REF. NO.	PART NO.	DESCRIPTION	QTY.
1	5007775SP	Foam Filled Tire Assembly 25" x 7" - 18"	1

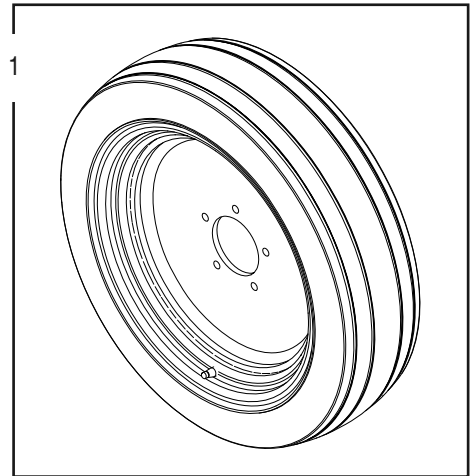

50068834SP FOAM FILLED TIRE ASSY.
26" x 6.6" - 14"

REF. NO.	PART NO.	DESCRIPTION	QTY.
1	50068834SP	Foam Filled Tire Assembly 26" x 6.6" - 14"	1

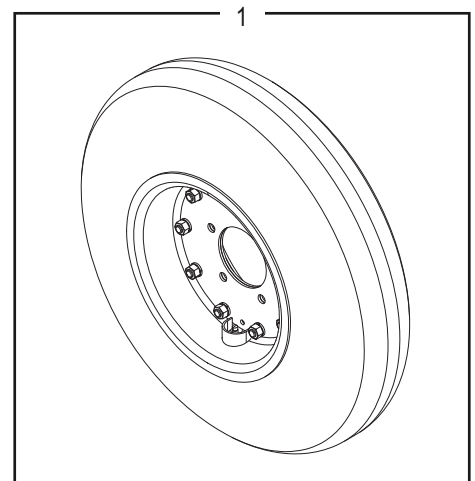

BAFFLE KIT FOR 3815R2 & 3810R2, 13815R2 & 13810R2 MODELS

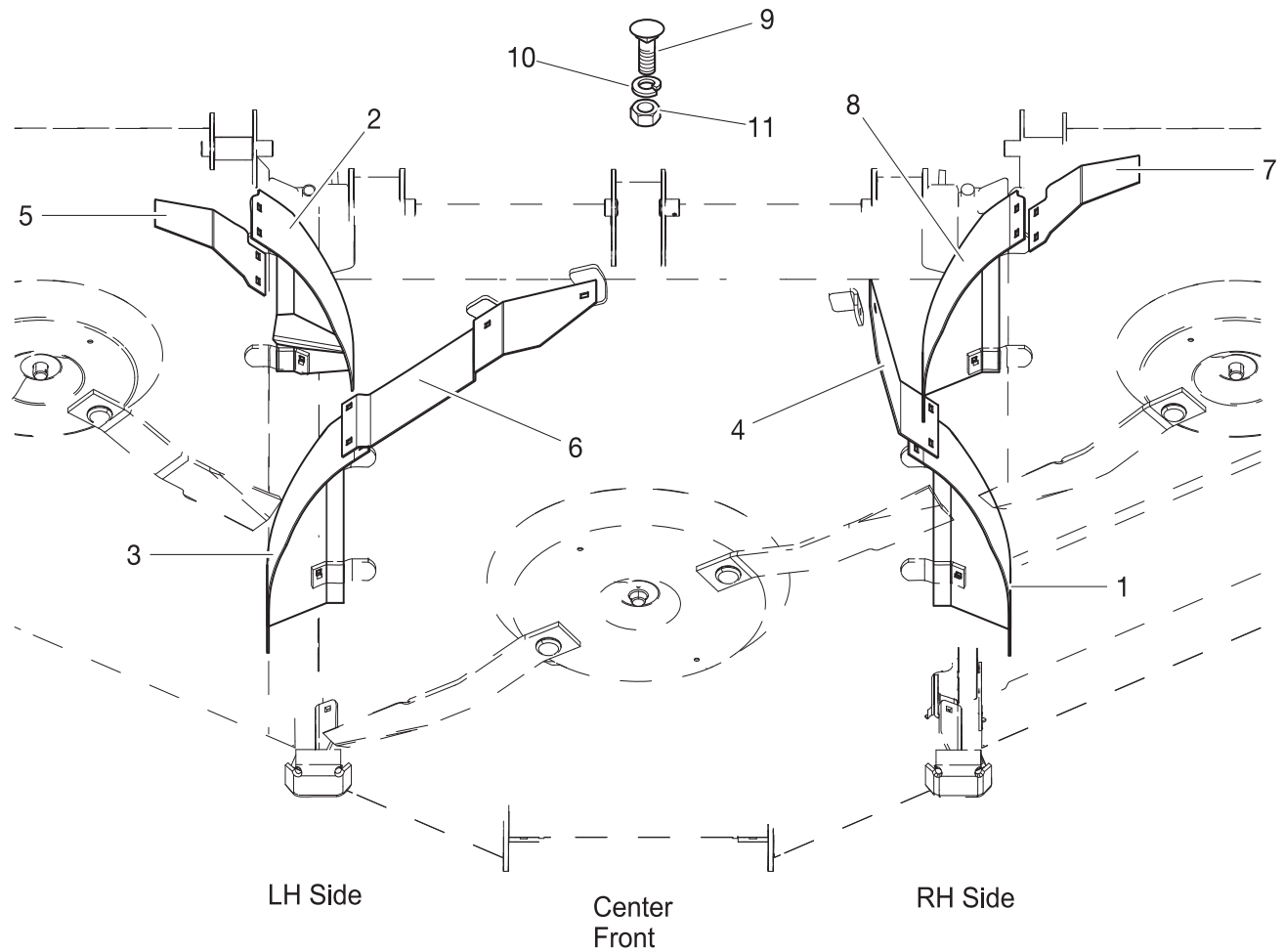

REF. NO.	PART NO.	DESCRIPTION	QTY.
1	50070222	Baffle Weldment R.H. Wing	1
2	50070223	Baffle Weldment L.H. Wing (3815, 13815 Only)	1
3	50070224	Baffle Weldment L.H. Center	1
4	50070225	Baffle Extension R.H. Center	1
5	50070228	Baffle Extension L.H. Wing (3815, 13815 Only)	1
6	50070229	Baffle Extension L.H. Center	1
7	50070232	Baffle Extension R.H. Wing	1
8	50070219	Baffle Weldment R.H. Wing	1
9	44286	Carriage Bolt, 3/8" x 1-1/2 Gr. 5	9
10	15802	Lockwasher, 3/8"	9
11	8151200	Hex Nut, 3/8"	9

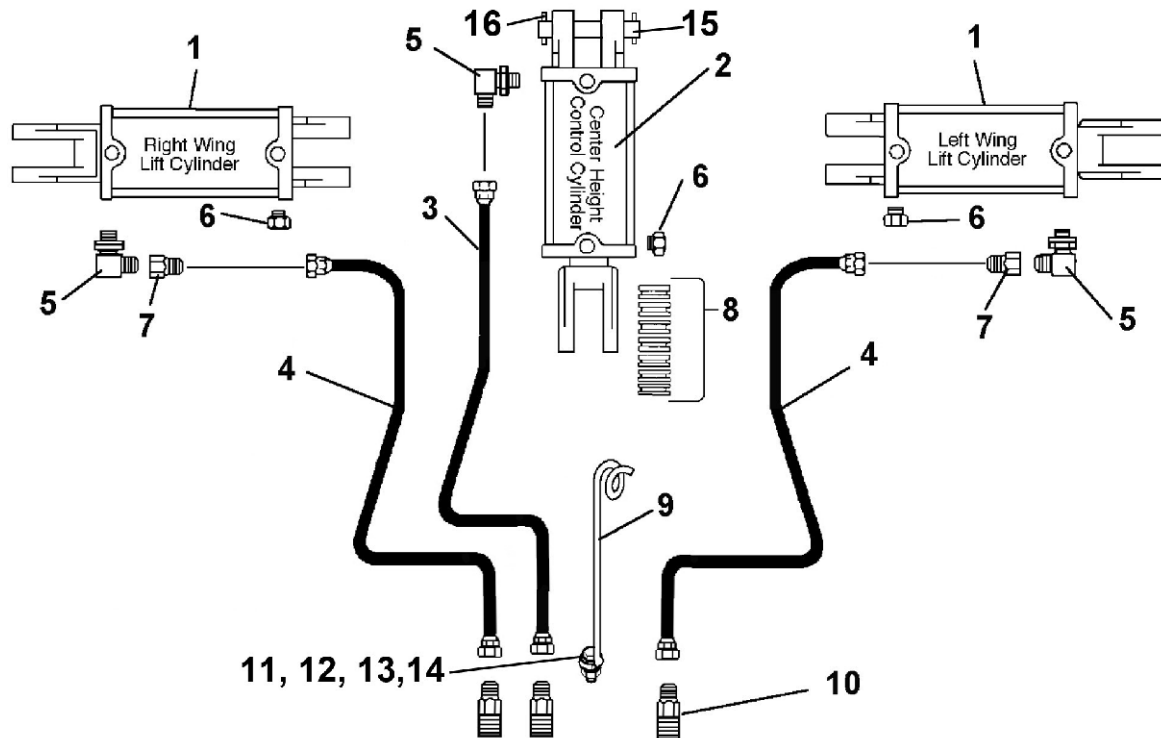

**HYDRAULICS FOR 3815R2 & 3810R2, 13815R2 & 13810R2 MODELS
WHEN PLUMBING TO TRACTOR REMOTES**

REF. NO.	PART NO.	DESCRIPTION	QTY.
1	99564	Wing Lift Cylinder	2
2	99565	Axle Control Cylinder	1
3	62774	Hydraulic Hose Assy. 228"	1
4	50015063	Hydraulic Hose Assy. 196"	2
5	14-40-98	Elbow 90 degree	3
6	86500	Breather Plug	3
7	50068458	Restrictor, .078 Orifice	2
8	63451	Stop Kit	1
9	12031	Rod,Hose Holder	1
10	53340BH	Adaptor 9/16 JIC to 3/4 SAE	3
	24-6-434	Adaptor 9/16 JIC to 1/2 NPT	3
11	20947	Capscrew, 5/8" x 2" Gr. 5	1
12	15925	Flatwasher, 5/8"	1
13	19486	Lockwasher, 5/8"	1
14	15563	Hex Nut, 5/8"	1
15	50069414	Cylinder Pin, 6-5/8" Lg.	1
16	20325	Roll Pin, 1/4" x 1-3/4"	2

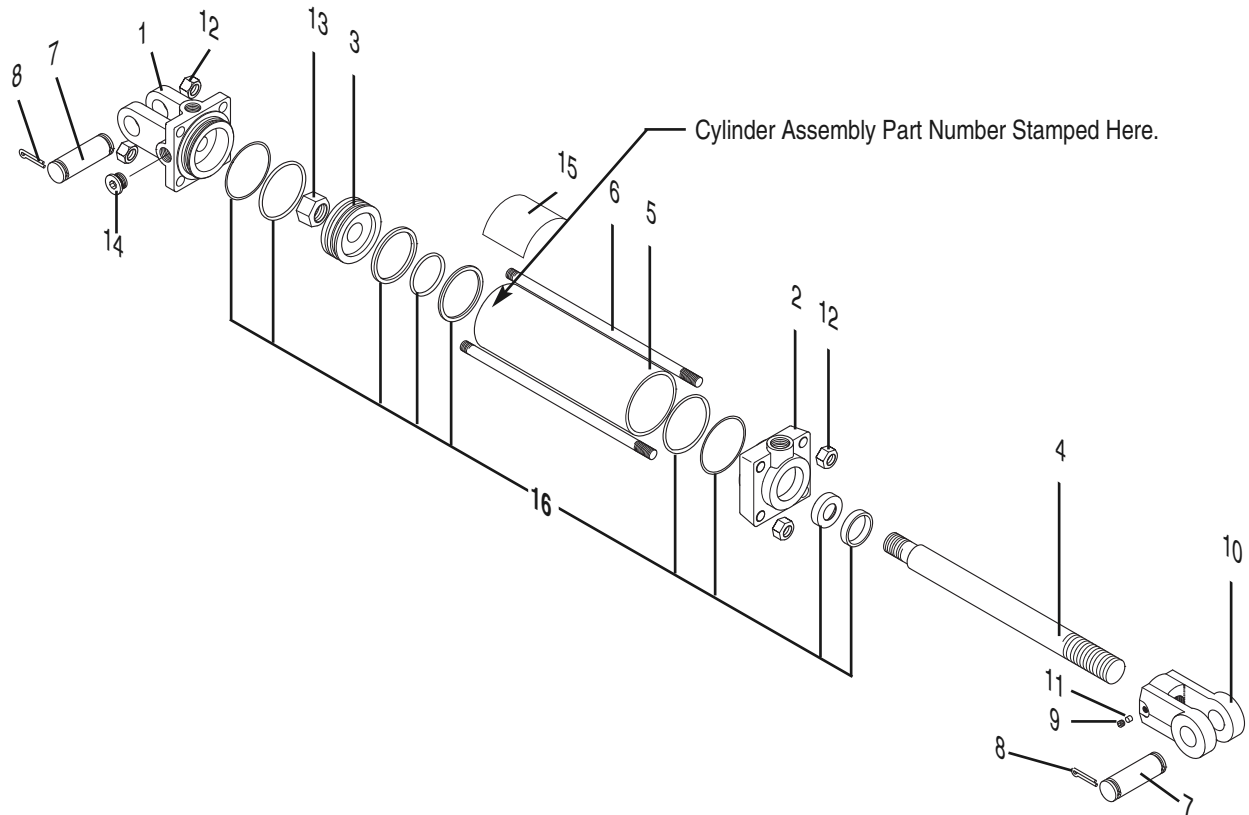

99565 AXLE HYDRAULIC CYLINDER
3.5" Bore x 8" Stroke 1.25 Rod Diameter
3/4" – 16 ORB Ports
Manufactured by Monarch

REF. NO.	PART NO.	DESCRIPTION	QTY.
1	95429	Clevis Cap	1
2	95430	Rod Cap	1
3	50017628	Piston	1
4	95431	Rod 1.25" Dia.	1
5	95426	Cylinder Tube	1
6	95427	Tie Rod	4
7	95425	Pin, 1" Dia.	2
8	21020614	Cotter Pin, 3/16" x 1-1/2"	4
9	95433	Thread Lock	1
10	95428	Rod Clevis, 1.25" x 1"	1
11	95422	Set Screw, 3/8" x 1/2 Knurled	1
12	95420	Hex Nut, 5/8" UNF	8
13	95421	Hex Nut, 1"-14	1
14	95435	Plug, 3/4"	1
15	50042072	Decal, Caution	1
16	50017623	Seal Kit	1

99564 WING HYDRAULIC CYLINDER
3" Bore x 12" Stroke 1.25" Rod Diameter
3/4" – 16 ORB Ports
Manufactured by Monarch

REF. NO.	PART NO.	DESCRIPTION	QTY.
1	95440	Clevis Cap	1
2	95439	Rod Cap	1
3	50017627	Piston	1
4	95436	Rod 1.25" Dia.	1
5	95437	Cylinder Tube	1
6	95438	Tie Rod	4
7	95425	Pin, 1" Dia.	2
8	21020614	Cotter Pin, 3/16" x 1-1/2"	4
9	95433	Thread Lock	1
10	95428	Rod Clevis, 1.25" x 1"	1
11	95422	Set Screw, 3/8" x 1/2 Knurled	1
12	8151600	Hex Nut, 1/2"-14 UNC	8
13	95421	Hex Nut, 1"-14	1
14	95435	Plug, 3/4"	1
15	50042072	Decal, Caution	1
16	50017622	Seal Kit	1



BUSH HOG[®]

2501 GRIFFIN AVE. • SELMA, AL 36703
WWW.BUSHHOG.COM