

These rugged, time-tested Anderson Hitches are a safe and efficient method of automatically coupling and uncoupling wagons to; Tractors - Balers - Harvesters & Pickers  
Anderson Hitches eliminate the frustrating job of backing into exact position for hook up

### AUTOMATIC COUPLER C/W BOLT ON BRACKET

- Hardened jaws lock in draw pin until you release it from the driver seat
- Bolts easily on any draw bar
- Heavy duty and compact

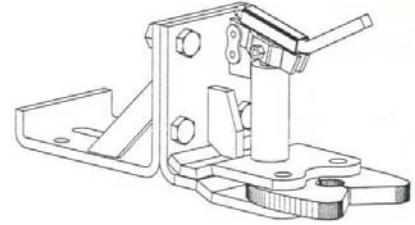

Mfg Part #	Description	Wt.
YM-281	Automatic coupler c/w bolt on bracket	20#

### ANDERSON AUTOMATIC WAGON HITCH C/W BOLT ON BRACKET

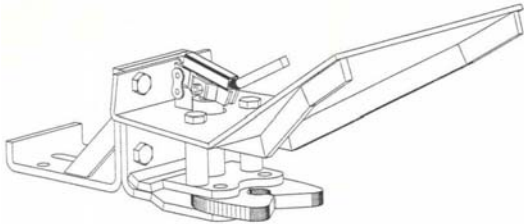

- Makes all wagon connections a simple one-man operation
- Rugged guide rails allow tongue to be approached from wide angle
- Maintains full turning radius
- SAFE – eliminates need to be in dangerous pinch area
- All mounting hardware included

Mfg Part #	Description	Wt.
AH-181	Automatic wagon hitch c/w bolt on bracket	38#

### ANDERSON DOUBLE SPRING TONGUE KIT C/W 3/4" x 4 1/2" ANDERSON DRAW PIN

- Two-spring system holds heavy or light tongue in position for connection with Automatic coupler – automatic wagon hitch
- Specially designed draw pin guides tongue into coupler

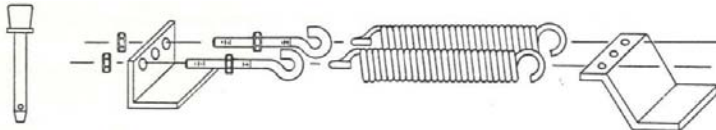

Mfg Part #	Description	Wt.
AH-381	Double spring tongue kit c/w 3/4" x 4-1/2" draw pin	17#

### ANDERSON DRAW PIN

Hardened draw pin is supplied with Anderson double spring tongue kit or can be purchased separately.

Mfg Part #	Description	Wt.
AH-480	3/4" x 4-1/2" Pin	1.5#
AH 481	7/8" x 5-1/2" Pin	

The complete hitch system is easily installed on your equipment and includes all mounting hardware

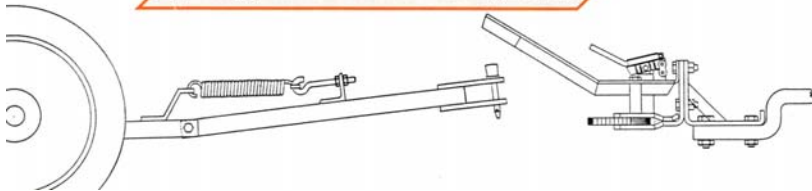

### AUTOMATIC COUPLER C/W 12" HANDLE EXTENSION

The ANDERSON EQUIPMENT HITCH line has been extended to include models for use with your baler and "Forage King" Haybasket

- Includes all features of automatic coupler described on page 1
- Has extended pipe handle to allow operation under bale chamber
- Simplifies coupling and uncoupling "Forage King" Haybasket

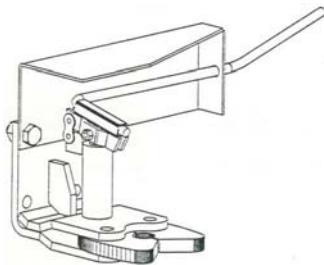

Mfg Part #	Description	Wt.
YM-282	Automatic coupler c/w 12" handle Extension	18#

DISTRIBUTED BY:



[www.walcoequipment.com](http://www.walcoequipment.com)

**HEAD OFFICE** 20 ARTHUR STREET NORTH, ELMIRA, ONTARIO N3B 1Z9  
TEL: (519) 669-4025 FAX: (519) 669-1436

**ORDER DESK** e-mail: [orders@walcoequipment.com](mailto:orders@walcoequipment.com)  
TEL: (519) 669-1401 FAX (519) 669-3499

**QUEBEC OFFICE** 364 RTE.122 ST.GERMAIN DE GRANTHAM, QUÉBEC JOC  
TEL: (819) 395-5115 Fax (819) 395-2624  
e-mail: [walcoqc@walcoequipment.com](mailto:walcoqc@walcoequipment.com)

**WALCO USA** 4469 292<sup>nd</sup> St. E. Box 57 Randolph MN 55065  
Tel: (507) 663-9090 Fax (507) 663-0999

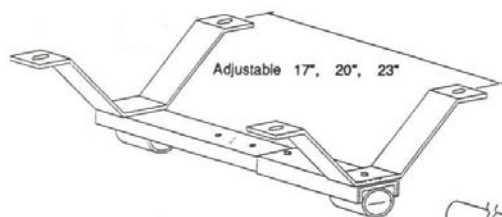

### AUTOMATIC COUPLER C/W 12" HANDLE EXTENSION/PIPE

Same as above – but addition of pipe makes it ready for mounting with baler center hitch bracket.

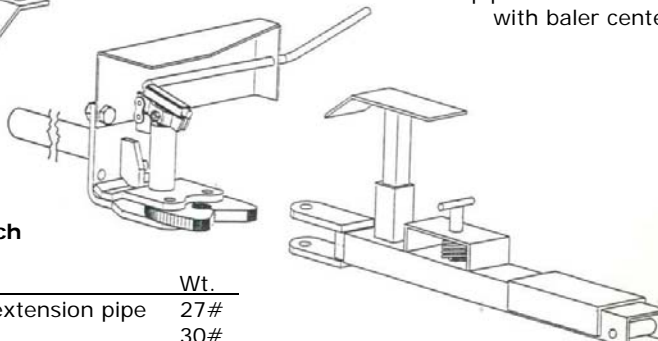

### BALER CENTRE HITCH BRACKET

- Designed to fit many balers
- Required if baler dose not have center hitch

MFG. Part #	Description	Wt.
YM-283	Automatic Coupler c/w 12" handle extension pipe	27#
YM-284	Baler Center Hitch Bracket	30#

### TONGUE KIT FOR 'FORAGE KING' HAYBASKET C/W 3/4" X 4 1/2" ANDERSON DRAW PIN



- Specifically designed to hold "Forage King" tongue up and in place, ready for smooth connection

Automatic Coupler c/w 12" handle extension  
Anderson Automatic Wagon Hitch for "Forage King" Haybasket

Mfg. Part No	Description	Wt.
AH-382	Tongue kit for "Forag King" Haybasket c/w 3/4" x 4-1/2" Anderson Draw Bar	5#

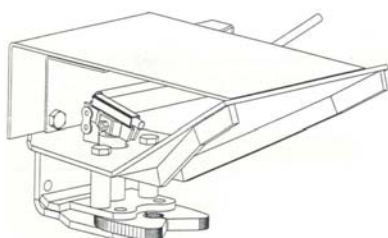

### ANDERSON AUTOMATIC WAGON HITCH FOR 'FORAGE KING' HAYBASKET

- Hitch designed specifically to work wit "Forage King" system
- Includes all features of Anderson Automatic Wagon hitch – page 1
- Makes baling a safe and efficient one man operation

Mfg. Part No.	Description	Wt.
AH-182	Anderson automatic wagon hitch for "forage King" aybasket	47#

### ANDERSON AUTOMATIC WAGON HITCH FOR 'FORAGE KING' HAYBASKET C/W PIPE

- Same as above – but addition of pipe makes this unit ready for mounting With baler center hitch bracket

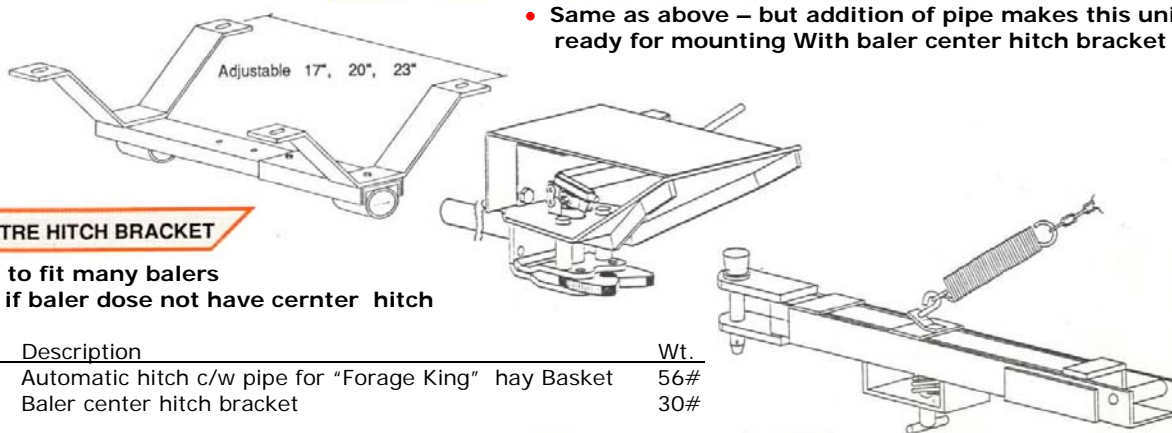

### BALER CENTRE HITCH BRACKET

- Designed to fit many balers
- Required if baler dose not have cernter hitch

Mfg. Part No	Description	Wt.
AH-183	Automatic hitch c/w pipe for "Forage King" hay Basket	56#
WC-284	Baler center hitch bracket	30#

### ANDERSON DRAW PIN

- Hardened draw pin is supplied wit Tongue Kit for "Forage King" Hay basket, or can be purchased separately

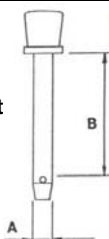

Mfg. Part No	Description	Wt.
AH-480	3/4" x 4-1/2" Anderson Draw Pin	1.5#
AH-481	7/8" x 5-1/2" Anderson Draw Pin	

### BOLT ON BRACKET

- Allows direct mounting on any Andereson Hitch to tractor or implement draw bar

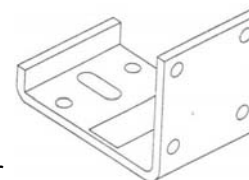

Mfg. Part No	Description	Wt.
YM-580	Bolt on bracket	7#