

RT 60B

Rototilt designed for excavators
with machine weight 15–24 tonnes (33,000–52,900 lb)



TECHNICAL DATA RT 60B	METRIC	IMPERIAL
Min/Max machine weight	15-24 tonnes	33,000 - 52,900 lb
Maximum standard bucket volume	1.1 m ³	1.4 yd ³
Maximum bucket digging force	170 kN	38,218 lb
Weight	from 460 kg*	1,014 lb
Tilting angle	2 x 40°	2 x 40°
Rotation	unlimited	unlimited
Rate of rotation (@50 l/min)	1 turn/7 seconds	1 turn/7 seconds
Min/Max connection pressure	20/30 MPa**	2900/4350 psi**
Working pressure	25 MPa	3626 psi
Max return pressure (@50 l/min)	2 MPa	290 psi
Min/Max connected flow	40/80 l/min	10.6/21.1 gpm
Number of lubrication points	8	8

* The weight depends on the type of adapter, quick coupler and control system.

** Separate connection for hydraulic motor max 25 MPa (3626 psi).

DIMENSIONS RT 60B	MM	INCH
Applies for RT 60B S60/S60		
A	795 mm	31.30 in
B	500 mm	19.69 in
C	790 mm	31.10 in
C ²	810 mm	31.89 in
D	855 mm	33.66 in
D ²	1095 mm	43.11 in

² With double acting cylinders

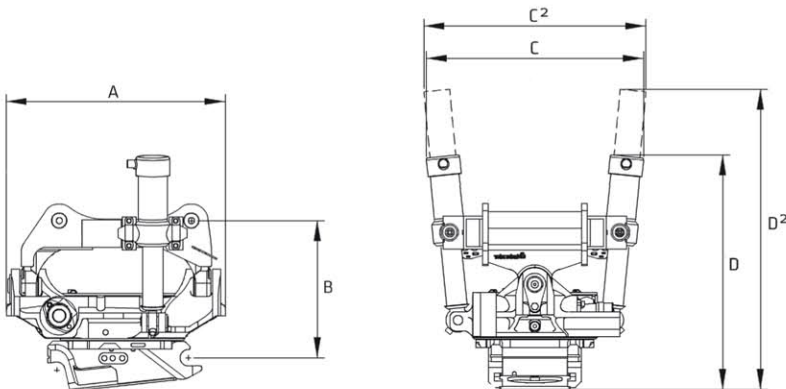

RT 60B S60/S60 with single acting cylinders
and grapple module G710

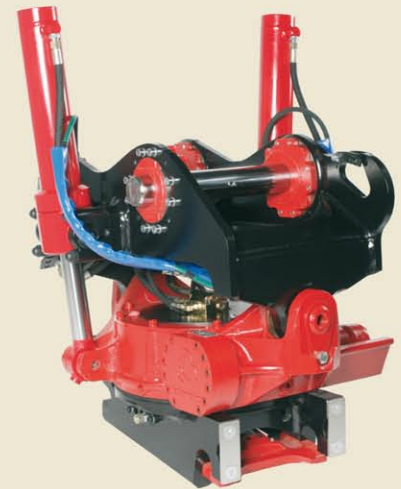

RT 60B Multi/S60 with double acting cylinders

The pictures above only show two of several possible configurations for the RT 60B.