



1260LP

Hoftrac

Technical Data

■ Standard engine data

Engine manufacturer	Perkins
Motor type	403 J-17
Cylinder	3
Drive output	18.4 kW
Drive output	25 PS
at max. rpm	2,800 U/min
Cylinder capacity	1,663 cm ³
Type of coolant	Water
Exhaust standard level	V
Exhaust aftertreatment	-

■ Electrical system

Operating voltage	12 V
Battery	77 Ah
Alternator	85 A

■ Weights

Operating weight	1,800 - 2,250 kg
Thrust force (max.)	2,069 - 2,582 daN
Lift capacity (max.)	1,779 - 2,395 daN
Tipping load with bucket – machine straight, loading frame horizontal	1,160 - 1,690 kg
Tipping load with bucket – machine pivoted, loading frame horizontal	980 - 1,440 kg
Tipping load with bucket - machine straight, loading frame in lowest position	1,770 - 2,760 kg
Tipping load with bucket - machine pivoted, loading frame in lowest position	1,490 - 2,340 kg
Tipping load with pallet fork – machine straight, loading frame horizontal	890 - 1,260 kg
Tipping load with pallet fork – machine pivoted, loading frame horizontal	740 - 1,080 kg
Tipping load with pallet fork - machine straight, transport position	1,070 - 1,580 kg
Tipping load with pallet fork - machine pivoted, transport position	900 - 1,340 kg

■ Driver's cab

Driver's cab	FSD (cabin)
--------------	-------------

■ Filling levels

Tank capacity for fuel	18 l
Tank capacity for hydraulic oil	18 l

■ Drive system

Type of drive	dwDrive (Direct Wheel Drive)
drive unit	Hydrostatic via four wheel hub motors
Speed levels	1
Travel speed Standard	0-20 km/h
Operating brake	Hydrostatic drive system acting on all 4 wheels
Parking brake	Electro-hydraulic multi-disc brake on the rear axle

■ Hydraulic system

Drive hydraulics working pressure (max.)	420 bar
Work hydraulics discharge volume (max.)	44,8 l/min
Work hydraulics working pressure (max.)	185 (225) bar

■ Kinematics

Kinematics type	P
Lifting cylinder	2
Tipping cylinder	1
Quick change system	Mechanical (hydraulically activated)

■ Steering

Steering type	hydraulically activated articulated pendulum steering
Steering cylinder	1
Oscillating angle	± 8 degree

■ Noise characteristic values

Average sound power level LwA (operator's canopy)	99.4 dB(A)
Guaranteed sound power level LwA (operator's canopy)	101 dB(A)
Specified sound pressure level LpA (operator's canopy)	84 dB(A)

Average sound power level LwA (cabin)	99.4 dB(A)
Guaranteed sound power level LwA (cabin)	101 dB(A)
Specified sound pressure level LpA (cabin)	80 dB(A)

■ Other information

FSD = operator's canopy
eps = Easy Protection System (fold-down operator's canopy)
DPF = diesel particulate filter
DOC = diesel oxidation catalyst
Tipping load calculation pursuant to ISO 14397

Dimensions

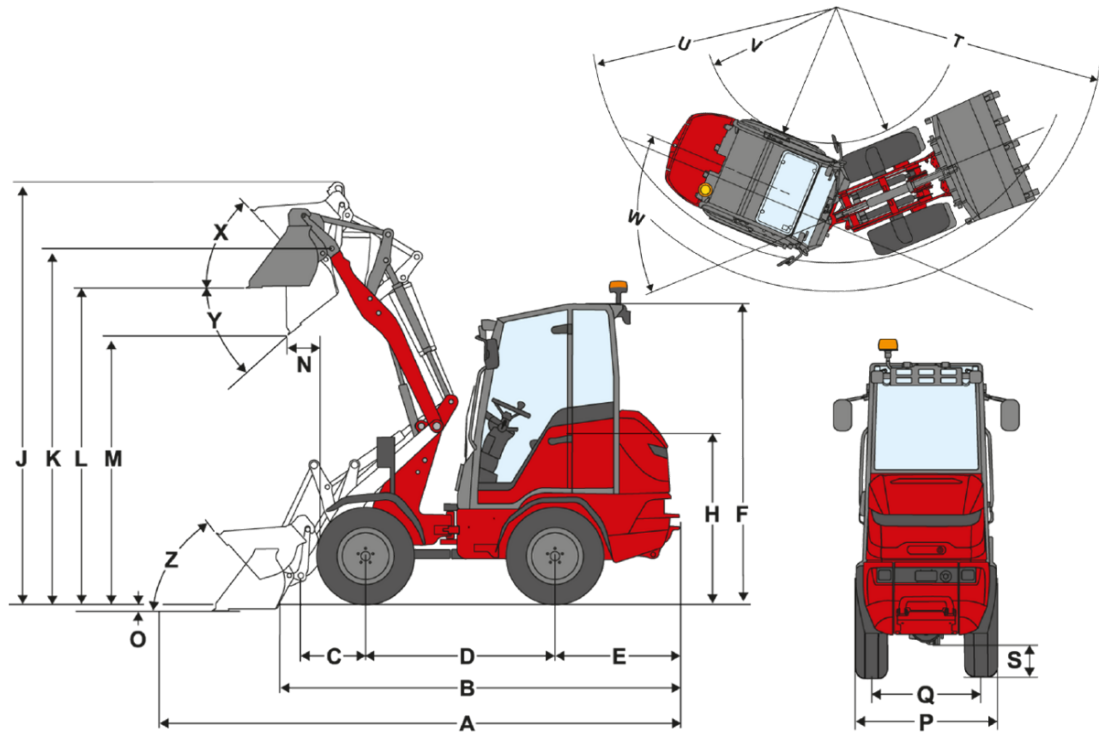

		P-kinematics (standard)	P-kinematics (long)	P-kinematics (very long)
	Standard components	27x8.50-15 BKT EM ET30	27x8.50-15 BKT EM ET30	27x8.50-15 BKT EM ET30
A	Total length	3,830 mm	3,830 mm	4,030 mm
B	Total length without bucket	3,240 mm	3,240 mm	3,440 mm
C	Bucket pivot point (to center of axle)	505 mm	505 mm	704 mm
D	Wheel base	1,670 mm	1,670 mm	1,670 mm
E	Rear overhang	955 mm	955 mm	955 mm
F	Height with operator's canopy fixed	1,980 mm	1,980 mm	1,980 mm
	Height with fold-down operator's canopy (eps)			
	Height with fold-down operator's canopy, folded down (eps)			
	Height with cab	1,990 mm	1,990 mm	1,990 mm
H	Seat height	1,000 mm	1,000 mm	1,000 mm
J	Total working height	3,050 mm	3,230 mm	3,440 mm
K	Bucket pivot point (max. lift height)	2,510 mm	2,700 mm	2,900 mm
L	Load-over height	2,220 mm	2,410 mm	2,620 mm
M	Dumping height	1,790 mm	2,040 mm	2,240 mm
N	Reach (at M)	80 mm	275 mm	
O	Digging depth	120 mm	100 mm	130 mm
P	Total width	980 mm	980 mm	980 mm
Q	Track width	761 mm	761 mm	761 mm
S	Ground clearance			
T	Maximum radius	3,100 mm	3,020 mm	3,020 mm
U	Radius on the outer edge	2,730 mm	2,730 mm	2,730 mm
V	Inner radius	1,610 mm	1,610 mm	1,610 mm
W	Articulation angle	43 °	43 °	43 °
X	Rollback angle at max. lift height	49 °	50 °	47 °
Y	Dumping angle	50 °	39 °	40 °
Z	Rollback angle on ground	48 °	48 °	49 °

Standard components

Engine

- Perkins 403 J-17, 18.4 kW / 25 hp, stage V

Tires

- 27 x 8,50 - 15 EM ET30

Steering system

- Hydraulic articulated pendulum steering
- Steering cylinder: 1

Operator's cab

- Overhead guard with restraint system ROPS / FOPS tested
- Generous space in all operator compartments
- Ergonomically spacious entrance
- Rear window
- Interior rear view mirror

Operator's seat

- Fully damped comfort seat with safety belt, weight, back and height adjustment

Lighting

- LED working lights: 2 front, 1 rear on the overhead guard

Drive system & Axles

- Drive: hydrostatic via four wheel hub motors (medium pressure)
- Speed: 20 km/h
- Driving stages: 1
- Service brake: Hydrostatic drive acting on all 4 wheels (wear-free)
- Parking brake: Electro-hydraulic multi-disc brake on the rear axle

Loading system

- Loading swing arm lifting height 2510 mm; quick coupler (Weidemann MV/HT - C) mechanical
- Kinematics: P
- Lifting cylinder: 2
- Tilting cylinder: 1
- Float position for lift and tilt cylinders

Hydraulics

- Mechanically pre-controlled joystick with direction switch
- 3rd Front control circuit via lever
- Hydraulic oil cooler

Options

Operator's cab

- 1-door cabin, incl. heater and fan (opening window on right)
- Artificial leather seat MSG 83
- Artificial leather seat; air-sprung MSG 93
- Artificial leather seat; air-sprung; heated seat MSG 93
- Fabric seat MSG 83
- Fabric seat; air-sprung MSG 93
- Fabric seat; air-sprung; heated seat MSG 93
- Radio DAB+-ready (aerial, speaker)
- Radio DAB+ complete
- 3-pole plug receptacle
- Adjustable steering column (inclination)

Lighting

- Lighting according to StVZO (incl. rear view mirror outside) (Width of lighting outside: 1004 mm)
- Worklights LED Performance (2000 lm) on the roof, 2 front, 2 rear
- Rotating beacon LED (yellow), The national regulations must be observed!

Approval & Road traffic

- Individual operating permit < 25 km/h
- License plate holder front and rear
- Warning plate triangular

Drive system & Axles

- Engine pre-heating (coolant) + hydraulic oil pre-heating 230 V
- Speed limiter proportional (slow speed device)

Tires

- 27x10.50-15 BKT EM ET-5, tread EM, width 1088 mm, height + 4.0 mm
- 255/75-15.3 Starco AS-Dumper ET-10, tread AS, width 1098 mm, height + 49.5 mm
- 27x10.0-15.3 BKT AS-504 ET0, tread AS, width 1082 mm, height + 9.5 mm
- 31x15.5-15 Mitas TR-07 ET-50, tread AS, width 1295 mm, height + 48.5 mm
- 400/50-15 Starco AS-Dumper ET-50, tread AS, width 1302 mm, height + 52.0 mm
- 260/70R16.5 Michelin BibSt ET-60, tread BS, width 1208 mm, height +48.5 mm
- 315/55 R16 Continental MPT81 ET-20, tread MPT81, width 1197 mm, height + 37.0 mm
- Tires turned

Loading system

- High lift height (2700 mm)
- High lift height (2900 mm)

Quick change plates

- Weidemann HV/HT - C (hydraulic)
- Weidemann HV/HT - C - ECS (hydraulic - easy coupler system)
- Euro (hydraulic - ISO23206 EURO HV) (incl. two couplers SVK size 3)
- SMS (hydraulic)
- Lowering brake valve (pipe breakage protection lifting and tipping cylinder)
- Load swing damping

Hydraulics

- Shell PANOLIN S4 HLP Synth 46 (bio hydraulic oil)

Hydraulics in front

- 3rd Control circuit via lever (two clutches flatface size 2) incl. detent for single control lever
- 3rd Control circuit comfort, incl. single detent on lever for 3rd Control circuit (operation: Via button on joystick + tilt in and tilt out)
- 4th Control circuit comfort, incl. single detent on lever for 3rd Control circuit (operation: Via button on joystick + tilt in and tilt out), (3rd Control circuit, front, can not be operated simultaneously)
- 4th Additional control circuit via 4-way valve, incl. single detent on lever for 3rd Control circuit (operation: Via separate lever)
- Front pressureless return (1 x Flatface size 3, plug) incl. leakage oil line (1 x Flatface size 2, plug)

Electrical connections in front

- Socket front 13-pin (2x electric functions E1/ E2 and lighting), (Operation: Via 1 switch on the steering column; 1st Function latching, 2nd Function latching)

Electrical connections in rear

- Rear socket 7-pole for lighting of rear attachments

Safety options

- Reversing alarm (acoustic)

Custom-made paint finish

- Special painting RAL single color - instead of Weidemann red
- Special painting RAL multicolored

Other

- Floor plate counterweight (100 kg)
- Toolbox, including tool set and hand lever grease press
- Combination box (for combination envelope)
- Combination bag (warning triangle / first aid kit)

Warranty extension*

- Economy 24 months (2500 h)
- Economy 36 months (3000 h)
- Economy 48 months (3500 h)
- Economy 60 months (4000 h)
- Premium 24 months (3000 h)
- Premium 36 months (4000 h)
- Premium 48 months (5000 h)
- Premium 60 months (6000 h)

*The offers regarding the warranty extension in Germany are currently being revised - more information will follow as quickly as possible.

EquipCare (telematics)

- EquipCare 36 months (incl. App & Manager)

Trailer and recovery equipment

- Maneuvering hitch (Not approved for trailer operation!)