



2080LPT

Telescopic wheel loaders

Technical Data

■ Standard engine data

Engine manufacturer	Deutz
Motor type	TD 2.9 L4 S5
Cylinder	4
Drive output	45 kW
Drive output	61 PS
at max. rpm	2,300 U/min
Cylinder capacity	2,900 cm ³
Type of coolant	Water
Exhaust standard level	V
Exhaust aftertreatment	DOC/DPF
Average sound power level LwA (operator's canopy)	98.5 dB(A)
Guaranteed sound power level LwA (operator's canopy)	99 dB(A)
Specified sound pressure level LpA (operator's canopy)	82 dB(A)
Average sound power level LwA (cabin)	98.5 dB(A)
Guaranteed sound power level LwA (cabin)	99 dB(A)
Specified sound pressure level LpA (cabin)	77 dB(A)

■ Engine data Option 1

Engine manufacturer	Deutz
Motor type	TCD 2.9 L4 S5
Cylinder	4
Drive output	55.4 kW
Drive output	75 PS
at max. rpm	2,300 U/min
Cylinder capacity	2,900 cm ³
Type of coolant	Water/charge air
Exhaust standard level	V
Exhaust aftertreatment	DOC/DPF
Average sound power level LwA (operator's canopy)	100.1 dB(A)
Guaranteed sound power level LwA (operator's canopy)	101 dB(A)

Specified sound pressure level LpA (operator's canopy)	85 dB(A)
Average sound power level LwA (cabin)	100.1 dB(A)
Guaranteed sound power level LwA (cabin)	101 dB(A)
Specified sound pressure level LpA (cabin)	78 dB(A)

■ Electrical system

Operating voltage	12 V
Battery	100 Ah
Alternator	95 A

■ Weights

Operating weight	4,400 kg
Tipping load with bucket – machine straight, loading frame horizontal	2,437 - 2,556 kg
Tipping load with bucket – machine pivoted, loading frame horizontal	2,041 - 2,152 kg
Tipping load with bucket – machine straight (extended)	1,359 - 1,437 kg
Tipping load with bucket – machine pivoted (extended)	1,139 - 1,219 kg
Tipping load with pallet fork – machine straight, loading frame horizontal	2,177 - 2,266 kg
Tipping load with pallet fork – machine pivoted, loading frame horizontal	1,796 - 1,907 kg
Tipping load with pallet fork – machine straight (extended)	1,287 - 1,364 kg
Tipping load with pallet fork – machine pivoted (extended)	1,053 - 1,125 kg

■ Driver's cab

Driver's cab	FSD (cabin)
--------------	-------------

■ Filling levels

Tank capacity for fuel	65 l
Tank capacity for hydraulic oil	50 l

■ Drive system

Type of drive	hydrostatic
drive unit	Cardan shaft
Speed levels	2
Axle	PA 1200

Travel speed Standard	0-20 km/h
Travel speed Option 1	0-28 km/h
Operating brake	Hydrostatic drive acting on all 4 wheels (wear-free)
Parking brake	Service and parking brake in the drive train acting on all 4 wheels
Differential lock	100% front axle rear axle

■ Hydraulic system

Drive hydraulics working pressure (max.)	450 bar
Work hydraulics discharge volume (max.)	57,5 (74) l/min
Work hydraulics working pressure (max.)	235 bar

■ Kinematics

Lifting cylinder	1
------------------	---

Tipping cylinder	1
Quick change system	hydraulic

■ Steering

Steering type	Hydraulic articulated pendulum steering
Steering cylinder	1
Oscillating angle	±12 degree

■ Other information

FSD = overhead guard
 DPF = Diesel Particulate Filter
 DOC = Diesel oxidation catalyst
 SCR = Selective Catalytic Reduction
 Tipping load calculation according to ISO 14397

Dimensions

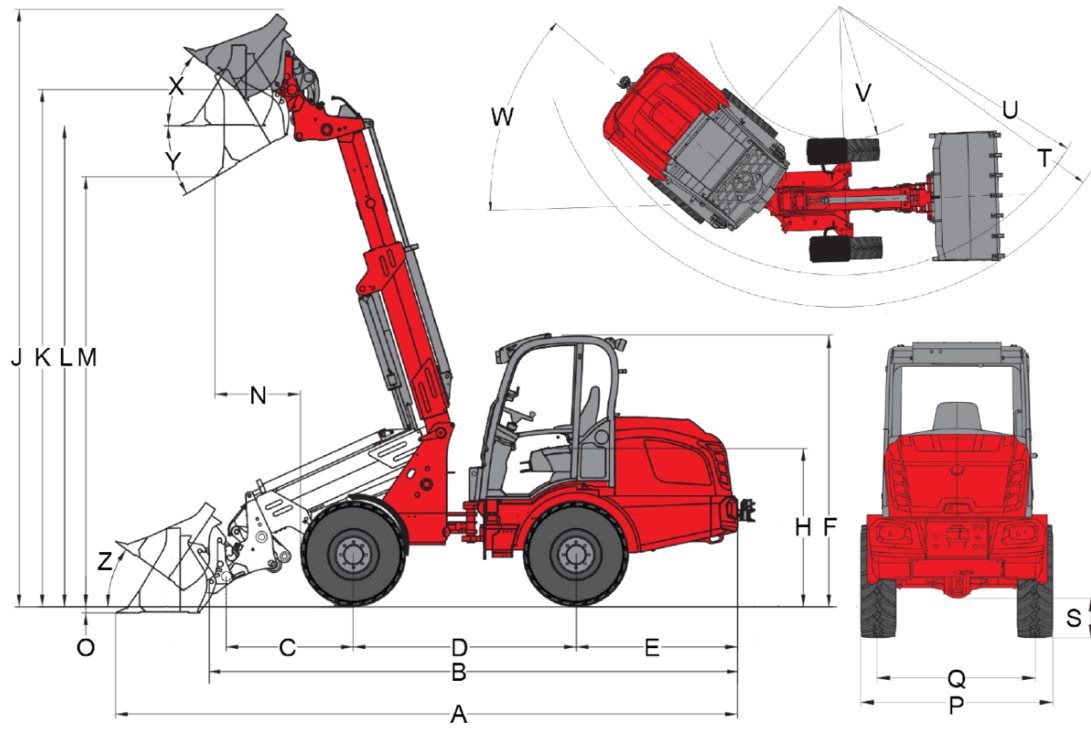

Telescopic arm (Z-kinematics)

	Standard components	11.5/80 - 15.3 AS ET40
A	Total length	5,420 mm
B	Total length without bucket	4,630 mm
C	Bucket pivot point (to center of axle)	875 mm
D	Wheel base	2,120 mm
E	Rear overhang	1,430 mm
F	Height with lowered operator's canopy	2,200 mm
	Height with operator's canopy raised	2,360 mm
	Height with cab lowered	2,200 mm
	Height with cab raised	2,400 mm
	Height with cab	
H	Seat height	1,250 mm
J	Total working height	5,020 mm
K	Bucket pivot point (max. lift height)	4,240 mm
L1	Load-over height telescopic arm retracted	
L	Load-over height telescopic arm extended	3,890 mm
	Load-over height	
M1	Dumping height telescopic arm retracted	
M	Dumping height	
	Dumping height telescopic arm extended	3,370 mm
N	Reach (at M)	878 mm
O	Digging depth	152 mm
P	Total width	1,410 mm
Q	Track width	1,120 mm
S	Ground clearance	296 mm
T	Maximum radius	3,820 mm
U	Radius on the outer edge	3,450 mm
V	Inner radius	1,860 mm
W	Articulation angle	43 °
X	Rollback angle at max. lift height	34 °
Y	Dumping angle	35 °
Z	Rollback angle on ground	32 °

The illustrations, equipment and data shown may deviate from the current delivery program of your country. Optional equipment subject to additional charge may be shown. Subject to changes.

Standard components

Engine

- Deutz TD 2.9 L4 S5, 45 kW / 61 hp, stage V

Tires

- 11.5/80-15.3 AS ET40, profile AS, width 1410 mm

Steering system

- Hydraulic articulated pendulum steering, pendulum angle $\pm 12^\circ$
- Steering cylinder: 1

Drive system & Axles

- Planetary axle PA1200
- 20 km/h
- Hydrostatic all-wheel drive, driving direction selectable via joystick
- Service brake: Hydrostatic drive acting on all 4 wheels (wear-free)
- Central service and parking brake in drive train acting on all 4 wheels
- Differential lock 100 %, electric-hydraulic switchable on front and rear axle

Hydraulics

- 3rd Control circuit, front DN12
- Hydraulic oil cooler
- Pressureless return in front
- Float position for lifting cylinder
- Locking device for control valve
- Discharge dampening in telescopic cylinder, both sides

Operator's cab

- Overhead guard with front and rear windows ROPS / FOPS tested
- Comfort seat with seat belt full suspension, weight, back and longitudinal adjustment
- Joystick with direction switch and integrated button for differential lock and telescopic function
- Worklights 2 front and 2 rear
- Operating hours meter
- Fuel gauge
- Adjustable steering column

Other

- Tool box in the rear of the vehicle
- Front socket 3-pin for double function (1st Function push-button, 2nd Function latching)

Loading system

- Lowering brake valve (pipe breakage protection lifting and tipping cylinder)

Quick change plates

- Weidemann hydraulic

EquipCare (telematics)

- EquipCare 36 months (incl. App & Manager)

Trailer and recovery equipment

- Self-recovery coupling (Not approved for trailer operation!)

Options

Operator's cab

- Low operator's canopy (work lights: 2x front and 2x rear)
- High operator's canopy (work lights: 2x front and 2x rear)
- Low, 2-door cabin, incl. heater and fan (work lights: 2x front and 2x rear)
- 2-door, high cabin, incl. heater and fan (2x front and 2x rear work lights)
- 1-door, high cabin, incl. heater and fan (2x front and 2x rear work lights)
- Radio DAB+-ready (aerial, speaker)
- Radio DAB+ complete
- Air-conditioning system

Operator's seat

- Leatherette seat (standard with overhead guard), (MSG 20)
- Leatherette seat; air suspension (MSG 75)
- Leatherette seat; air suspension; heated seats (MSG 75)
- Fabric seat (standard in cab), (MSG 20)
- Fabric seat; air suspension (MSG 75)
- Fabric seat; air suspension; heated seats (MSG 75)

Lighting

- Lighting according to StVZO
- LED working lights, 2 front 2 rear
- Rotating beacon (yellow), (National regulations must be observed!)

StVZO – equipment

- Individual operating permit > 25 km/h
- Individual operating permit > 25 km/h
- Registration plate mounting

Engine

- Deutz TCD 2.9 L4 S5, 55.4 kW / 75 hp, stage V
- Hand throttle
- Engine preheating (cooling water) + hydraulic oil preheating 230 V

Drive system & Axles

- 28 km/h (Speed increase)
- Hand inching (low-speed control)

Tires

- 15.0/55-17 AS ET0, profile AS, width 1600 mm
- 15.0/55-17 AS ET-40, profile AS, width 1660 mm
- 425/55 R 17 AS ET-40 Alliance 570, profile AS, width 1700 mm
- 15.5/55 R 18 EM ET0, profile EM, width 1570 mm
- 33x15.50-15 RP ET-37, profile RP, width 1680 mm
- 12-16.5 Sure Trax ET0 BKT, profile SureTrax, width 1530 mm

Water filling

- Water filling valves without filling (front wheels)
- Water filling valves without filling (rear wheels)
- Water filling valves without filling (front and rear wheels)
- Water filling valves with filling (front wheels)
- Water filling valves with filling (rear wheels)
- Water filling valves with filling (front and rear wheels)

Loading system

- Water filling valves with filling (front and rear wheels)

Quick change plates

- Euro hydraulic
- Matbro hydraulic
- Kramer hydraulic
- Volvo TPV hydraulic
- SMS hydraulic

Hydraulics in front

- Working hydraulics (74 l/min) Large pump
- Changeover valve at the front of the 3rd Control circuit (3rd Control circuit with 4 connections), (Operation: Selection via switch (0 - 1) in the joystick console)
- 3rd Control circuit proportional incl. double detent via switch (operation: Via control wheel at the front of the joystick)
- Quick coupling Faster 4-fold - machine side
- Quick coupling Faster 4-fold - attachment side

Hydraulics in rear

- Pressureless return in rear
- One hydraulic connection rear double-acting via changeover valve (l/min like 3rd Control circuit front), (3rd Control circuit front or rear), (Operation: Via switch (0 - 1) in joystick console + 3rd control circuit)

Bio-hydraulic oil

- Shell PANOLIN S4 HLP Synth 46 (Bio-hydraulic oil)

Electrical connections in front

- Front socket 3-pin for double function (operation: Via 2 buttons on the joystick; 1st Function latching, 2nd Function push-button)
- Front socket 3-pin for double function (operation: Via 2 buttons on the joystick; 1st Function push-button, 2nd Function push-button)
- Front socket 3-pin for double function (operation: Via 2 buttons on the joystick; 1st Function latching, 2nd Function latching)

Electrical connections in rear

- Rear 7-pin socket for lighting rear attachments
- Rear 3-pin socket (operation: Via switch (1 - 0 - 2) in joystick console)

Additional weight

- Ballast weight base plate (122 kg)

Safety options

- Reversing alarm (acoustic)

Other

- Reverse alarm (acoustic), (disconnection of the on-board power supply and the generator via 2 switching paths from the battery)
- Hand lever grease press
- Combination bag (warning triangle / first aid kit)
- Set of tools
- Fully automatic central lubrication unit

Warranty extension*

- Economy 24 months (2500 h)
- Economy 36 months (3000 h)
- Economy 48 months (3500 h)
- Economy 60 months (4000 h)
- Premium 24 months (3000 h)
- Premium 36 months (4000 h)
- Premium 48 months (5000 h)
- Premium 60 months (6000 h)

*The offers regarding the warranty extension in Germany are currently being revised - more information will follow as quickly as possible.

Custom-made paint finish

- Special painting RAL single color - instead of Weidemann red
- Special painting RAL multicolored

Trailer and recovery equipment

- Trailer hitch automatic

Self-propelled work machines with ball hitch

- Trailer hitch automatic