



2080T

Telescopic wheel loaders

Technical Data

■ Standard engine data

Engine manufacturer	Deutz
Motor type	TD 2.9 L4 S5
Cylinder	4
Drive output	45 kW
Drive output	61 PS
at max. rpm	2,300 U/min
Cylinder capacity	2,900 cm ³
Type of coolant	Water
Exhaust standard level	V
Exhaust aftertreatment	DOC/DPF

■ Engine data Option 1

Engine manufacturer	Deutz
Motor type	TCD 2.9 L4 S5
Cylinder	4
Drive output	55.4 kW
Drive output	75 PS
at max. rpm	2,300 U/min
Cylinder capacity	2,900 cm ³
Type of coolant	Water/charge air
Exhaust standard level	V
Exhaust aftertreatment	DOC/DPF

■ Electrical system

Operating voltage	12 V
Battery	100 Ah
Alternator	95 A

■ Weights

Operating weight	4,600 kg
Tipping load with bucket – machine straight, loading frame horizontal	2,714 kg
Tipping load with bucket – machine pivoted, loading frame horizontal	2,260 kg

Tipping load with bucket – machine straight (extended)	1,562 kg
Tipping load with bucket – machine pivoted (extended)	1,295 kg
Tipping load with pallet fork – machine straight, loading frame horizontal	2,383 kg
Tipping load with pallet fork – machine pivoted, loading frame horizontal	1,999 kg
Tipping load with pallet fork – machine straight (extended)	1,455 kg
Tipping load with pallet fork – machine pivoted (extended)	1,213 kg

■ Driver's cab

Driver's cab	Cab
--------------	-----

■ Filling levels

Tank capacity for fuel	75 l
Tank capacity for hydraulic oil	50 l

■ Drive system

Type of drive	Hydrostatic
drive unit	universal joint shaft
Speed levels	2
Axle	PA 1200
Travel speed Standard	0-20 km/h
Travel speed Option 1	0-28 km/h
Operating brake	Hydrostatic drive system acting on all 4 wheels (wear-free)
Parking brake	Service and parking brake in the drive train acts on all 4 wheels
Differential lock	100 % front axle + rear axle

■ Hydraulic system

Drive hydraulics working pressure (max.)	450 bar
Work hydraulics discharge volume (max.)	57,5 (74) l/min
Work hydraulics working pressure (max.)	235 bar

■ Kinematics

Lifting cylinder	1
Tipping cylinder	1

Quick change system	hydraulic
---------------------	-----------

■ **Steering**

Steering type	Hydraulically activated articulated pendulum steering
---------------	---

Steering cylinder	1
-------------------	---

Oscillating angle	±12 degree
-------------------	------------

■ **Noise characteristic values**

Average sound power level LwA (cabin)	99.9 dB(A)
---------------------------------------	------------

Guaranteed sound power level LwA (cabin)	101 dB(A)
Specified sound pressure level LpA (cabin)	74 dB(A)

■ **Other information**

FSD = operator's canopy
 DPF = diesel particulate filter
 DOC = diesel oxidation catalyst
 SCR = selective catalytic reduction
 Tipping load calculation according to ISO 14397

Dimensions

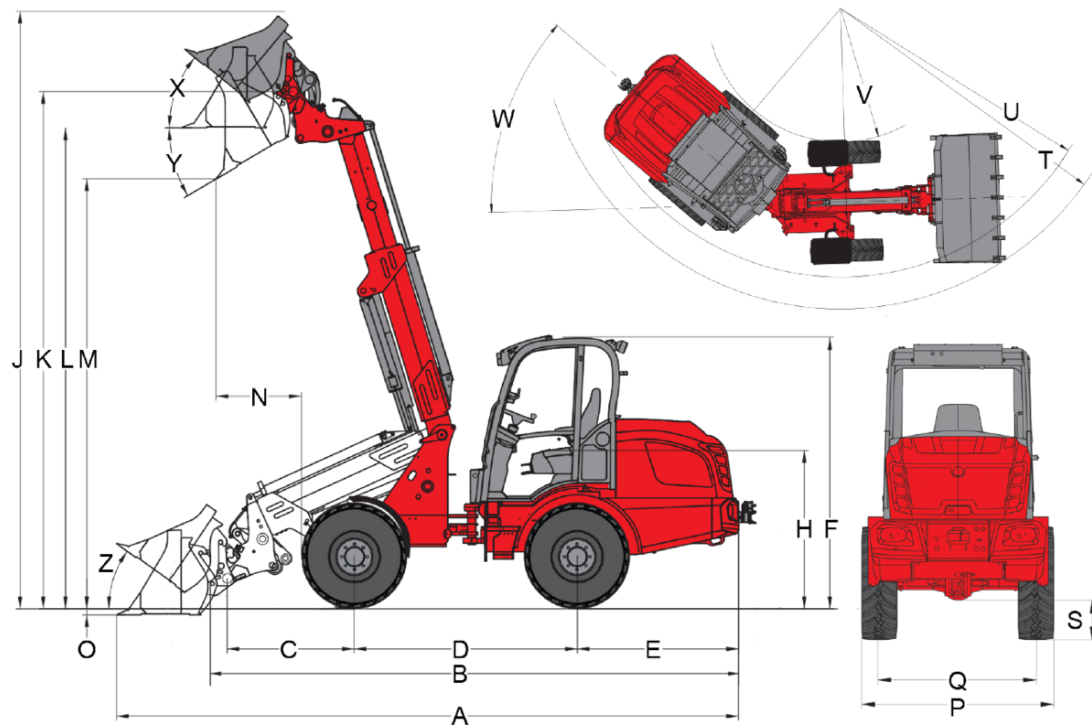

Telescopic arm (Z-kinematics)

	Standard components	11.5/80 - 15.3 AS ET40
A	Total length	5,500 mm
B	Total length without bucket	4,190 mm
C	Bucket pivot point (to center of axle)	680 mm
D	Wheel base	2,050 mm
E	Rear overhang	1,420 mm
F	Height with lowered operator's canopy	
	Height with operator's canopy raised	
	Height with cab lowered	2,360 mm
	Height with cab raised	2,540 mm
	Height with cab	
H	Seat height	1,430 mm
J	Total working height	5,080 mm
K	Bucket pivot point (max. lift height)	4,290 mm
L1	Load-over height telescopic arm retracted	
L	Load-over height telescopic arm extended	3,940 mm
	Load-over height	
M1	Dumping height telescopic arm retracted	
M	Dumping height	
	Dumping height telescopic arm extended	3,400 mm
N	Reach (at M)	890 mm
O	Digging depth	150 mm
P	Total width	1,410 mm
Q	Track width	1,120 mm
S	Ground clearance	300 mm
T	Maximum radius	3,830 mm
U	Radius on the outer edge	3,320 mm
V	Inner radius	1,730 mm
W	Articulation angle	45 °
X	Rollback angle at max. lift height	40 °
Y	Dumping angle	33 °
Z	Rollback angle on ground	32 °

The illustrations, equipment and data shown may deviate from the current delivery program of your country. Optional equipment subject to additional charge may be shown. Subject to changes.

Standard components

Engine

- Deutz TD 2.9 L4 S5, 45 kW / 61 hp, stage V

Tires

- 11.5/80 - 15.3 AS ET40, profile AS, width 1.410 mm

Steering system

- Hydraulic articulated pendulum steering, pendulum angle $\pm 12^\circ$
- Steering cylinder: 1

Drive system

- Hydrostatic all-wheel drive, driving direction selectable via joystick
- Service brake: Hydrostatic drive acting on all 4 wheels (wear-free)
- Central service and parking brake in drive train acting on all 4 wheels
- Differential lock 100 %, electric-hydraulic switchable on front and rear axle

Hydraulics

- 3rd Front control circuit proportional via joystick, incl. double detent
- Hydraulic oil cooler
- Pressureless return in front
- Float position for lifting cylinder
- Discharge dampening in telescopic cylinder (both sides)

Operator's cab

- Comfort cab 2-doors low
- Comfort cab with heating and ventilation
- Laterally tiltable
- ROPS / FOPS tested
- Comfort seat with seat belt full suspension, weight, back and longitudinal adjustment
- Hydraulically pilot-controlled joystick with direction switch and integrated pushbutton for differential lock and proportional telescopic function
- Worklights 2 front and 2 rear
- Operating hours meter
- Fuel gauge
- Adjustable steering wheel

Other

- Tool box in the rear of the vehicle
- Lighting system according to StVZO
- Front socket 3-pin for double function (1st Function push-button, 2nd Function latching)
- Self-recovery coupling

Loading system

- Lowering brake valve (pipe breakage protection lifting and tipping cylinder)

Quick change plates

- Weidemann hydraulic

EquipCare (telematics)

- EquipCare 36 months (incl. App & Manager)

Options

Operator's cab

- 2-door, comfort cabin, high
- Storage box with bottle holder (left next to the operator's seat)
- Radio DAB+-ready (aerial, speaker)
- Radio DAB+ complete
- Air-conditioning system
- Cabin outlet 230 V (connection power max. 2000 W), (Only works with connected engine pre-heating on the 230 V grid)

Operator's seat

- Fabric seat; heated seats (MSG 85)
- Fabric seat; air suspension (MSG 95AL/722)
- Fabric seat; air suspension; heated seats (MSG 95AL/732)

Lighting

- LED work lights, 2 in front, 2 in rear
- Rotating beacon (yellow) (National regulations must be observed!)

StVZO – equipment

- Individual operating permit > 25 km/h
- Individual operating permit > 25 km/h
- Registration plate mounting

Engine

- Turbo diesel engine Deutz / TCD 2.9 L4 S5 DPF / 55.4 kW (75 hp) / emission standard: Stage V
- Hand throttle
- Engine preheating (cooling water)
- Hydraulic oil preheating 230 V

Drive system & Axles

- 28 km/h (Speed increase)
- Hand inching (low-speed control)

Tires

- 15.0/55-17 AS ET0, profile AS, width 1600 mm
- 15.0/55-17 AS ET-40, profile AS, width 1660 mm
- 425/55 R 17 AS ET-40 Alliance 570, profile AS, width 1700 mm
- 15.5/55 R 18 EM ET0, profile EM, width 1570 mm
- 33x15.50-15 RP ET-37, profile Rasenprofil, width 1680 mm
- 12-16.5 Sure Trax ET0 BKT, profile SureTrax, width 1530 mm

Water filling

- Water filling valves without filling (front wheels)
- Water filling valves without filling (rear wheels)
- Water filling valves without filling (front and rear wheels)
- Water filling valves with filling (front wheels)
- Water filling valves with filling (rear wheels)
- Water filling valves with filling (front and rear wheels)

Loading system

- Load swing damping

Quick change plates

- Euro hydraulic
- Matbro hydraulic
- Kramer hydraulic
- Volvo TPV hydraulic
- SMS hydraulic

Hydraulics in front

- Working hydraulics (74 l/min) Large pump
- Changeover valve at the front of the 3rd Control circuit (3 Control circuit with 4 connections), (operation: Selection via switch (0 - 1))
- Quick coupling Faster 4-fold - machine side

- Quick coupling Faster 4-fold - attachment side
- Additional hydraulic oil cooler

Hydraulics in rear

- Pressureless return in rear
- One hydraulic connection rear double-acting via changeover valve (l/min like 3rd Control circuit front), (3rd Control circuit front or rear), (Operation: Via switch (0 - 1) in joystick console + 3rd control circuit)
- One rear hydraulic connection (51 l/min) double-acting (two couplings) incl. separate control valve (Operation: Via switch (1 - 0 - 2) in joystick console)
- Two rear hydraulic connections (51 l/min) double-acting (four couplings) incl. separate control valve, (operation: 1 DW connection via switch (1 - 0 - 2), 1 DW connection via pushbutton (1 - 0 - 2)), (connections can be operated simultaneously)

Bio-hydraulic oil

- Shell PANOLIN S4 HLP Synth 46 (Bio-hydraulic oil)

Electrical connections in front

- Front socket 3-pin for double function (operation: Via 2 buttons on the joystick; 1st Function latching, 2nd Function push-button)
- Front socket 3-pin for double function (operation: Via 2 buttons on the joystick; 1st Function push-button, 2nd Function push-button)
- Front socket 3-pin for double function (operation: Via 2 buttons on the joystick; 1st Function latching, 2nd Function latching)

Electrical connections in rear

- Rear 7-pin socket for lighting rear attachments
- Rear 3-pin socket (operation: Via switch (1 - 0 - 2) in joystick console)

Additional weight

- Ballast weight base plate (122 kg)

Safety options

- Reversing warning device (acoustic)
- Immobilizer (operation via coded ignition key)

Other

- Battery disconnect switch 2 circuits (disconnection of the on-board power supply and the generator via 2 switching paths from the battery)
- Hand lever grease press
- Combination bag (warning triangle / first aid kit)
- Set of tools
- Fully automatic central lubrication unit

Warranty extension*

Economy 24 months (2500 h)

Economy 36 months (3000 h)

Economy 48 months (3500 h)

Economy 60 months (4000 h)

Premium 24 months (3000 h)

Premium 36 months (4000 h)

Premium 48 months (5000 h)

Premium 60 months (6000 h)

*The offers regarding the warranty extension in Germany are currently being revised - more information will follow as quickly as possible.

Custom-made paint finish

- Special painting RAL single color - instead of Weidemann red
- Special painting RAL multicolored

Trailer and recovery equipment

- Trailer hitch automatic

Self-propelled work machines with ball hitch

- Trailer hitch automatic