



## 5080T

### Telescopic wheel loaders

#### Technical Data

##### ■ Standard engine data

Engine manufacturer	Perkins
Motor type	904J-E36TA
Cylinder	4
Drive output	100 kW
Drive output	136 PS
at max. rpm	2,200 U/min
Cylinder capacity	3,621 cm <sup>3</sup>
Type of coolant	Water
Exhaust standard level	V
Exhaust aftertreatment	DOC/DPF/SCR

##### ■ Electrical system

Operating voltage	12 V
Battery	135 Ah
Alternator	85 A

##### ■ Weights

Operating weight	7,200 kg
Tipping load with bucket – machine straight, loading frame horizontal	4,365 kg
Tipping load with bucket – machine pivoted, loading frame horizontal	3,659 kg
Tipping load with bucket – machine straight (extended)	2,561 kg
Tipping load with bucket – machine pivoted (extended)	2,133 kg
Tipping load with pallet fork – machine straight, loading frame horizontal	4,103 kg
Tipping load with pallet fork – machine pivoted, loading frame horizontal	3,448 kg
Tipping load with pallet fork – machine straight (extended)	2,560 kg
Tipping load with pallet fork – machine pivoted (extended)	2,128 kg

##### ■ Driver's cab

Driver's cab	Cab
--------------	-----

##### ■ Filling levels

Tank capacity for fuel	105 l
------------------------	-------

Tank capacity for hydraulic oil	95 l
Tank capacity for urea solution	19 l

##### ■ Drive system

Type of drive	Hydrostatic
drive unit	universal joint shaft
Speed levels	2
Axle	PA 1422/2
Travel speed Standard	0-20 km/h
Travel speed Option 1	0-30 km/h
Travel speed Option 2	0-40 km/h
Operating brake	Disc brake (combined with parking brake)
Parking brake	Service and parking brake in the drive train acts on all 4 wheels
Differential lock	100 % front axle + rear axle

##### ■ Hydraulic system

Drive hydraulics working pressure (max.)	455 bar
Work hydraulics discharge volume (max.)	100 (115-150) l/min
Work hydraulics working pressure (max.)	235 bar

##### ■ Kinematics

Lifting cylinder	1
Tipping cylinder	1
Quick change system	hydraulic

##### ■ Steering

Steering type	Hydraulically activated articulated pendulum steering
Steering cylinder	2
Oscillating angle	±12 degree

##### ■ Noise characteristic values

Average sound power level L <sub>wA</sub> (cabin)	101.4 dB(A)
Guaranteed sound power level L <sub>wA</sub> (cabin)	103 dB(A)
Specified sound pressure level L <sub>pA</sub> (cabin)	74 dB(A)

■ **Other information**

FSD = operator's canopy  
DPF = diesel particulate filter

DOC = diesel oxidation catalyst  
SCR = selective catalytic reduction  
Tipping load calculation according to ISO 14397

## Dimensions

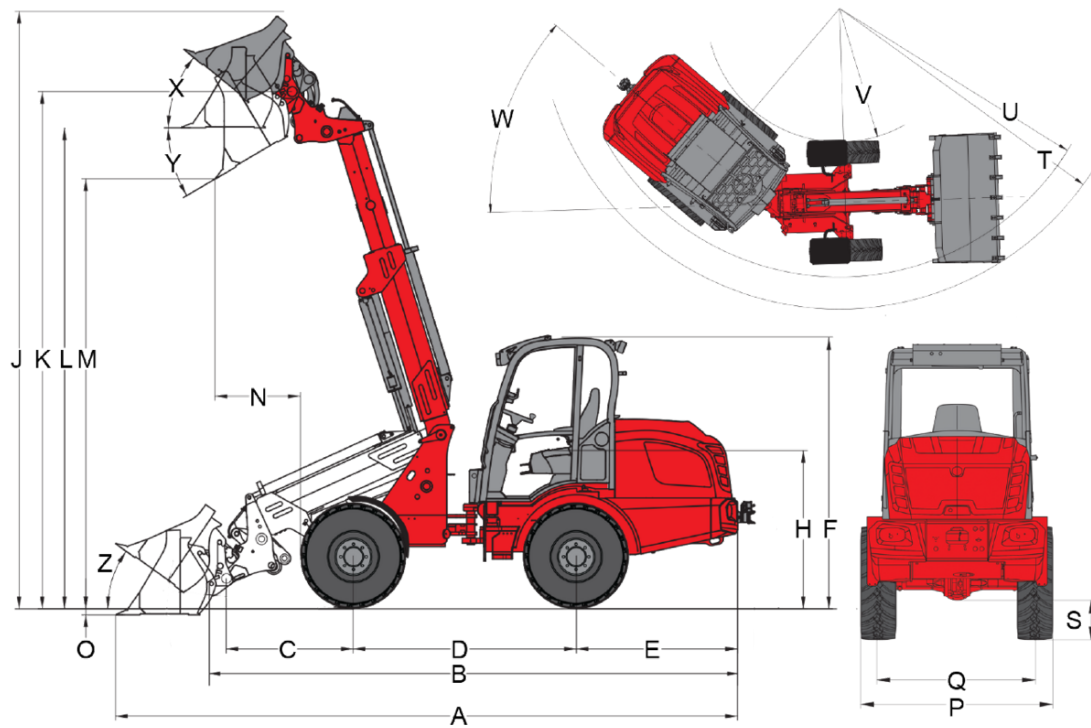

### Telescopic arm (Z-kinematics)

	Standard components	550/45-22.5 AS ET0
<b>A</b>	Total length	6,200 mm
<b>B</b>	Total length without bucket	5,230 mm
<b>C</b>	Bucket pivot point (to center of axle)	1,250 mm
<b>D</b>	Wheel base	2,190 mm
<b>E</b>	Rear overhang	1,580 mm
<b>F</b>	Height with lowered operator's canopy	
	Height with operator's canopy raised	
	Height with cab lowered	
	Height with cab raised	
	Height with cab	2,690 mm
<b>H</b>	Seat height	1,620 mm
<b>J</b>	Total working height	5,890 mm
<b>K</b>	Bucket pivot point (max. lift height)	5,090 mm
<b>L1</b>	Load-over height telescopic arm retracted	
<b>L</b>	Load-over height telescopic arm extended	4,720 mm
	Load-over height	
<b>M1</b>	Dumping height telescopic arm retracted	
<b>M</b>	Dumping height	
	Dumping height telescopic arm extended	4,090 mm
<b>N</b>	Reach (at M)	800 mm
<b>O</b>	Digging depth	60 mm
<b>P</b>	Total width	1,972 mm
<b>Q</b>	Track width	1,422 mm
<b>S</b>	Ground clearance	380 mm
<b>T</b>	Maximum radius	4,470 mm
<b>U</b>	Radius on the outer edge	3,930 mm
<b>V</b>	Inner radius	1,850 mm
<b>W</b>	Articulation angle	42 °
<b>X</b>	Rollback angle at max. lift height	37 °
<b>Y</b>	Dumping angle	36 °
<b>Z</b>	Rollback angle on ground	36 °

The illustrations, equipment and data shown may deviate from the current delivery program of your country. Optional equipment subject to additional charge may be shown. Subject to changes.

# Standard components

## Engine

- Perkins 904J-E36TA, 100 kW / 136 hp, stage V

## Tires

- 550/45-22.5 AS ET0, profile AS, width 1990 mm

## Steering system

- Hydraulic articulated pendulum steering, pendulum angle  $\pm 12^\circ$
- Steering cylinder: 2

## Drive system & Axles

- Axle PA1422/2
- 20 km/h
- Hydrostatic all-wheel drive, driving direction selectable via joystick
- Service brake: Disc brake (combined with parking brake)
- Central service and parking brake in drive train acting on all 4 wheels
- Differential lock 100% electric-hydraulic engageable on front and rear axles

## Hydraulics

- 3rd Front control circuit electrically proportional parallel via joystick, incl. double detent
- Hydraulic oil cooler
- Float position for lifting cylinder
- Pressureless return in front
- Oil quantity adjustment via jog dial
- Pressure relief of hydraulic connections on loading swing arm
- Discharge dampening in telescopic cylinder, both sides

## Operator's cab

- Comfort cab with heating and ventilation, laterally tiltable, ROPS / FOPS tested
- Comfort seat with seat belt full suspension, weight, back and longitudinal adjustment
- Adjustable steering wheel (inclination)
- Right armrest
- Hydraulically pilot-controlled joystick with direction switch and integrated pushbutton for differential lock and proportional telescopic function
- Worklights 2 front and 2 rear
- Operating hours meter
- Fuel gauge

## Other

- Lighting system according to StVZO
- Front socket 3-pin for double function (1st Function push-button, 2nd Function latching)

## Loading system

- Lowering brake valve (pipe breakage protection lifting and tipping cylinder)

## Quick change plates

- Weidemann hydraulic

## EquipCare (telematics)

- EquipCare 36 months (incl. App & Manager)

## Trailer and recovery equipment

- Self-recovery coupling (Not approved for trailer operation!)

# Options

## Operator's cab

- Front window protective grating
- Storage box with bottle holder (left next to the operator's seat)
- Radio DAB+-ready (aerial, speaker)
- Radio DAB+ complete
- Air-conditioning system (height +25 mm)
- Cabin outlet 230 V (connection power max. 2000 W), (Only works with connected engine pre-heating on the 230 V grid)

## Operator's seat

- Fabric seat; heated seats (MSG 85)
- Fabric seat; air suspension (MSG 95AL/722)
- Fabric seat; air suspension; heated seats (MSG 95AL/732)

## Lighting

- LED working lights, 2 front 2 rear
- Rotating beacon (yellow), The national regulations must be observed!

## StVZO – equipment

- Individual operating permit > 25 km/h
- Individual operating permit > 25 km/h
- Registration plate mounting

## Engine

- Manual throttle
- Engine pre-heating (coolant) + hydraulic oil pre-heating 230 V

## Drive system & Axles

- 30 km/h (speed increase)
- 40 km/h (speed increase)
- Manual inching (slow speed device)
- Front mudflap (mounted on the fender)

## Tires

- 400/70-20 AS ET0 AS504, tread AS, width 1840 mm
- 400/70-20 AS ET-50 AS504, tread AS, width 1930 mm
- 500/45-20 AS ET0, tread AS, width 1920 mm
- 550/45-22.5 AS ET-50, tread AS, width 2080 mm
- 600/40-22.5 AS ET-50, tread AS, width 2120 mm
- 405/70 R 18 EM Alliance 608 ET0, tread EM, width 1815 mm
- 405/70 R 20 EM Alliance 608 ET0, tread EM, width 1829 mm
- 340/80 R 18 ET0 Alliance Multiuse 550, tread Multiuse, width 1770 mm
- 400/70 R 20 ET0 Alliance Multiuse 550, tread Multiuse, width 1830 mm
- 400/70 R 20 ET-60 Alliance Multiuse 550, tread Multiuse, width 1950 mm
- 400/70 R 20 ET-50 Michelin Bibload, tread Bibload, width 1944 mm

## Loading system

- Load swing damping

## Quick change plates

- Euro hydraulic
- Matbro hydraulic
- Kramer hydraulic
- Volvo TPV hydraulic
- SMS hydraulic

## Hydraulics in front

- 3rd Control circuit Flow Sharing 100 l/min (Charging swing arm can be operated together with 3rd Control circuit)
- 3rd Control circuit Flow Sharing 115 l/min (Loading swing arm can be operated together with 3rd Control circuit)
- 3rd Control circuit Flow Sharing Load-Sensing 150 l/min (machine height +30 mm!), (loading swing arm can be operated together with 3rd Control circuit)
- Changeover valve at the front of the 3rd Control circuit (3rd Control circuit with 4 connections), (Operation: Selection via switch (0 - 1))
- Additional hydraulic oil cooler
- Quick coupling Faster 4-fold - machine side
- Quick coupling Faster 4-fold - attachment side

### Hydraulics in rear

- Pressureless return in rear
- One hydraulic connection rear double-acting via changeover valve (l/min like 3rd Control circuit front), (3rd Control circuit front or rear), (Operation: Via switch (0 - 1) in joystick console + 3rd control circuit)
- One rear hydraulic connection (63 l/min) double-acting (two couplings) incl. separate control valve (Operation: Via switch (1 - 0 - 2) in joystick console)
- Two rear hydraulic connections (63 l/min) double-acting (four couplings) incl. separate control valve, operation: 1 DW connection via switch (1 - 0 - 2), 1 DW connection via pushbutton (1 - 0 - 2), (connections can be operated simultaneously)

### Bio-hydraulic oil

- Shell PANOLIN S4 HLP Synth 46 (Bio-hydraulic oil)

### Electrical connections in front

- Front socket 3-pin for double function (operation: Via 2 buttons on the joystick; 1st Function latching, 2nd Function push-button)
- Front socket 3-pin for double function (operation: Via 2 buttons on the joystick; 1st Function push-button, 2nd Function push-button)
- Front socket 3-pin for double function (operation: Via 2 buttons on the joystick; 1st Function latching, 2nd Function latching)

### Electrical connections in rear

- Rear 7-pin socket for lighting rear attachments
- Rear 3-pin socket, operation: Via switch (1 - 0 - 2) in joystick console

### Safety options

- Reversing warning device (acoustic)
- Immobilizer (operation via coded ignition key)
- Lockable DEF tank cap

### Other

- Battery disconnect switch 2 circuits (disconnection of the on-board power supply and the generator via 2 switching paths from the battery)
- Hand lever grease press
- Combination bag (warning triangle / first aid kit)
- Tool box
- Set of tools
- Drive shaft protection
- Fully automatic central lubrication unit

### Warranty extension\*

- Economy 24 months (2500 h)
- Economy 36 months (3000 h)
- Economy 48 months (3500 h)
- Economy 60 months (4000 h)
- Premium 24 months (3000 h)
- Premium 36 months (4000 h)
- Premium 48 months (5000 h)
- Premium 60 months (6000 h)

\*The offers regarding the warranty extension in Germany are currently being revised - more information will follow as quickly as possible.

### Custom-made paint finish

- Special painting RAL single color - instead of Weidemann red
- Special painting RAL multicolored

### Trailer and recovery equipment

- Trailer hitch automatic
- Trailer hitch height adjustable, automatic
- Trailer hitch height adjustable, ball head
- Trailer Hitch

### Self-propelled work machines with ball hitch

- Trailer hitch automatic