



ET65

Tracked Conventional Excavator

the most powerful in its class

The ET65 is an excavator that users want. A high-performance machine that surprises with its compact design and maneuverability. The strong excavation performance thanks to high digging forces and the powerful engine are additional plus points that make the excavator an all-rounder on the construction site.

Highlights

- Powerful drive system with LUDV
- Triple boom
- 3-point kinematics
- More cab comfort
- Up to four additional factory-installed control circuits

Technical Data

Hydraulic

Operating pressure hydraulics	240.0 bar
Hydraulic pump	Variable displacement and gear pump
flow rate	144.0 l/min
flow rate max.	144.0 l/min
tank capacity	92.0 l

Mechanical - Output Details

Travel speed	5.2 km/h
--------------	----------

Mechanical Details

Length	6,137.0 mm
Width	1,950.0 mm
Height	2,478.0 mm
Operating weight (min.-max.)	6,078.0 - 7,358.0 kg
Digging depth (max.)	4,184.0 mm

Engine

Cooling	Water-cooling
Engine type	Turbodiesel engine

Cylinder	4.0
Cylinder capacity	2,216.0 cm ³
Inclined position max.	30.0 °
Kraftstofftyp	Diesel EN 590
Effective power	42.0 KW
Nominal Engine speed	2,000.0 1/min
Exhaust-gas limit	EU Stage V
Battery capacity (nom. value)	100.0 Ah
Engine Manufacturer	Perkins
Engine Designation	404J-E22T

Environment Data

Sound level LpA	77.0 dB(A)
Sound power LWA, guaranteed	97.0 dB(A)

Chassis

operating pressure	240.0 bar
--------------------	-----------

Shipping and Storage

Shipping weight	5,806.0 kg
-----------------	------------

Dimensions

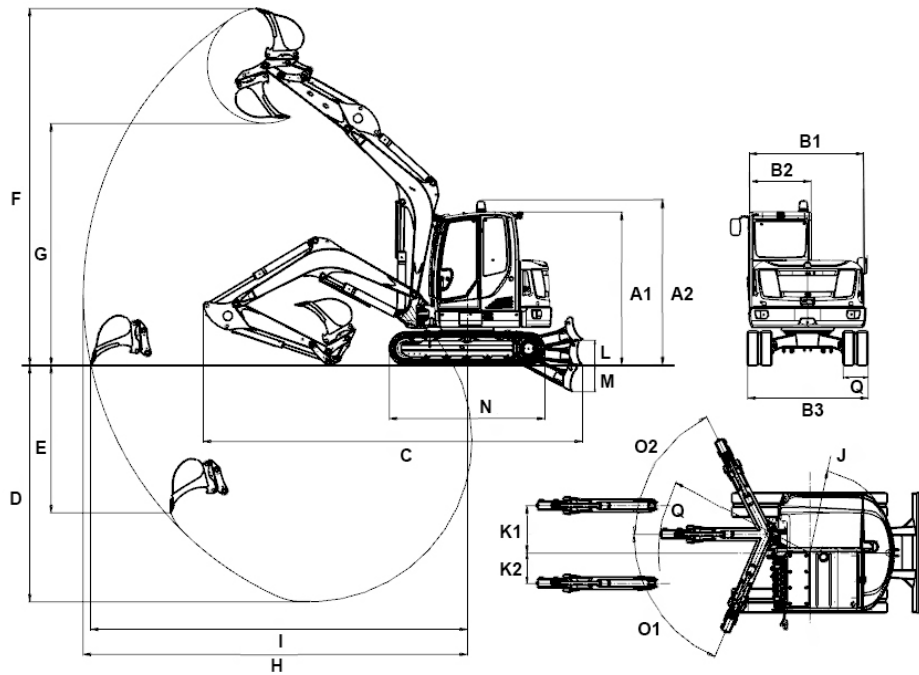

A1	Height with cab	2,478 mm
A3	Height of dozer blade	423 mm
A2	Total height with rotating beacon	2,654 mm
B1	Width of upper carriage	1,902 mm
B2	Width of cab	1,000 mm
B3	Width travel gear	1,950 mm
B5	Width of dozer blade	1,950 mm
C	Transport length short shovel arm	6,137 mm
	Transport length long shovel arm	6,128 mm
D	Digging depth max., short shovel arm	3,826 mm
	Digging depth max., long shovel arm	4,126 mm
E	Piercing depth max., short shovel arm	2,383 mm
	Piercing depth max., long shovel arm	2,656 mm
F	Piercing height max., short shovel arm	5,773 mm
	Piercing height max., long shovel arm	5,955 mm
G	Dumping height max., short shovel arm	3,912 mm
	Dumping height max., long shovel arm	4,094 mm
H	Digging radius max., short shovel arm	6,220 mm
	Digging radius max., long shovel arm	6,504 mm
I	Max. reach at ground level (short shovel arm)	6,097 mm
	Max. reach at ground level (long shovel arm)	6,387 mm
J	Tail swing radius	1,363 mm
	Tail swing radius with tail weight	1,481 mm
K1	Boom offset max. (to center of bucket right side)	766 mm
K2	Boom offset max. (to center of bucket left side)	492 mm
L	Stacking height max. (dozer blade above surface)	403 mm
M	Digging depth max. (dozer blade below surface)	427 mm
N	Length travel drive	2,516 mm
O1	Max. swivel angle (arm system to the left)	67 °
O2	Max. swivel angle (arm system to the right)	63 °
P1	Track width	400 mm
Q1	Boom swing radius center	2,453 mm
Q2	Boom swing radius right	2,372 mm
Q3	Boom swing radius left	1,902 mm