



## TH412

### Telehandler

#### Compact and powerful

All wheel steering, low centre of gravity and excellent stability distinguish the TH412 telehandler. The integrated driver assistance system VLS (Vertical Lift System) ensures safety, while also increasing the operator comfort. The electronically regulated drive system with various operator modes enables an externally productive work operation with the machine. Thanks to its low operating weight and very compact dimensions, the TH412 can be transported on a car trailer without any problems. This makes its flexible for use in many different areas.

## Highlights

- Electronically controlled drive system
- Electric parking brake
- VLS (Vertical Lift System)
- Colour-oriented operating concept
- Compact and powerful

## Technical Data

### ■ Standard engine data

Engine manufacturer	Yanmar
Motor type	3TNV80FT
Cylinder	3
Drive output	18.4 kW
Drive output	25 PS
at max. rpm	2,600 U/min
Cylinder capacity	1,226 cm <sup>3</sup>
Type of coolant	Water
Exhaust standard level	V
Exhaust aftertreatment	-
Average sound power level LwA (cabin)	99.5 dB(A)
Guaranteed sound power level LwA (cabin)	101 dB(A)
Specified sound pressure level LpA (cabin)	84 dB(A)

### ■ Engine data Option 1

Engine manufacturer	Yanmar
Motor type	3TNV86CHT
Cylinder	3
Drive output	33.3 kW
Drive output	45.3 PS
at max. rpm	2,600 U/min

Cylinder capacity	1,568 cm <sup>3</sup>
Type of coolant	Water
Exhaust standard level	V
Exhaust aftertreatment	DOC/DPF
Average sound power level LwA (cabin)	101.2 dB(A)
Guaranteed sound power level LwA (cabin)	102 dB(A)
Specified sound pressure level LpA (cabin)	84 dB(A)

### ■ Electrical system

Operating voltage	12 V
Battery	77 Ah
Alternator	80 A

### ■ Weights

Payload (max.)	1,250 kg
Operating weight	2,750 - 2,900 kg

### ■ Driver's cab

Driver's cab	Cab
--------------	-----

### ■ Filling levels

Tank capacity for fuel	33 l
Tank capacity for hydraulic oil	36 l

### ■ Drive system

Type of drive	Electronically controlled
---------------	---------------------------

drive unit	Hydrostatic via transfer gearbox and universal joint shaft
Speed levels	2
Axle	PAL 1155
Travel speed Standard	0-20 km/h
Travel speed Option 1	0-30 km/h
Differential lock	100 % front axle + rear axle

#### ■ Hydraulic system

Drive hydraulics working pressure (max.)	380 bar
Work hydraulics discharge volume (max.)	36,4 (41,6-70) l/min
Work hydraulics working pressure (max.)	220 bar

#### ■ Kinematics

Lifting cylinder	1
Tipping cylinder	1
Quick change system	hydraulic

#### ■ Steering

Steering type	Hydrostatic all-wheel steering with end position synchronization
Steering cylinder	2
Steering angle max.	2x38 degree
Oscillating angle of the rear axle	± 7 degree

#### ■ Other information

DPF = diesel particulate filter  
 DOC = diesel oxidation catalyst  
 SCR = selective catalytic reduction

## Dimensions

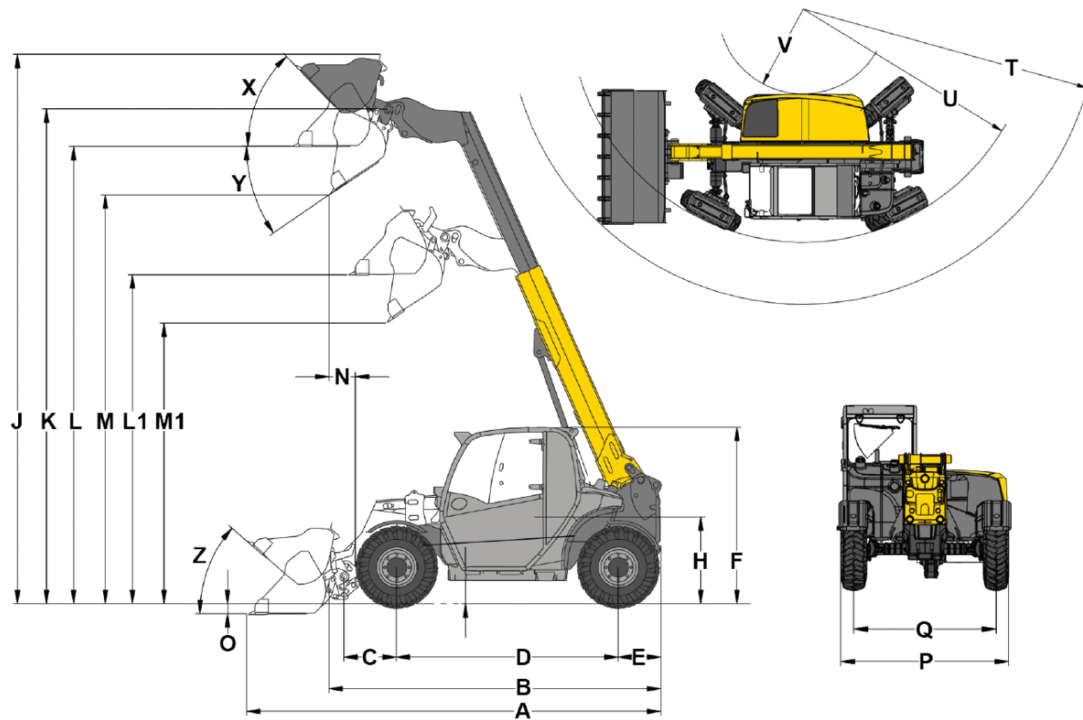

A	Total length	3,944 mm
B	Total length without bucket	2,991 mm
C	Bucket pivot point (to center of axle)	450 mm
D	Wheel base	1,922 mm
E	Rear overhang	427 mm
F	Height with cab	1,995 mm
H	Seat height	978 mm
J	Total working height	5,280 mm
K	Bucket pivot point (max. lift height)	4,537 mm
L1	Load-over height telescopic arm retracted	2,949 mm
L	Load-over height telescopic arm extended	4,163 mm
M1	Dumping height telescopic arm retracted	2,415 mm
M	Dumping height telescopic arm extended	3,630 mm
N	Reach (at M)	557 mm
O	Digging depth	96 mm
P	Total width	1,564 mm
Q	Track width	1,235 mm
S	Ground clearance	294 mm
T	Maximum radius	3,506 mm
U	Radius on the outer edge	2,695 mm
V	Inner radius	951 mm
X	Rollback angle at max. lift height	52 °
Y	Dumping angle	31 °
Z	Rollback angle on ground	44 °