



## WL28

### Wheel Loader

#### Compact and Powerful

Transporting heavy loads through tight spaces is the ideal operational area for the WL28 wheel loader. It can easily handle pallets of paving stones or other material up to 1.6 metric tons. The electronically-controlled travel drive with various travel modes enables extremely productive work using the machine. The low-designed cab ensures excellent visibility and high tipping loads. Because of the outstanding visibility, the machine offers exceptional safety during operation. The low operating weight also allows the WL28 to be transported on a car trailer.

### Highlights

- Comfort cab
- Electronically regulated drive system
- Electric parking brake
- High productivity thanks to the low front carriage
- The wheel loader as an attachment carrier

### Technical Data

#### ■ Standard engine data

Engine manufacturer	Yanmar
Motor type	3TNV80FT
Cylinder	3
Drive output	18.4 kW
Drive output	25 PS
at max. rpm	2,600 U/min
Cylinder capacity	1,226 cm <sup>3</sup>
Type of coolant	Water
Exhaust standard level	V
Exhaust aftertreatment	-
Average sound power level LwA (operator's canopy)	99.3 dB(A)
Guaranteed sound power level LwA (operator's canopy)	101 dB(A)
Specified sound pressure level LpA (operator's canopy)	84 dB(A)
Average sound power level LwA (cabin)	99.3 dB(A)
Guaranteed sound power level LwA (cabin)	101 dB(A)
Specified sound pressure level LpA (cabin)	80 dB(A)

#### ■ Engine data Option 1

Engine manufacturer	Yanmar
Motor type	3TNV86CHT
Cylinder	3

Drive output	33.3 kW
Drive output	45.3 PS
at max. rpm	2,600 U/min
Cylinder capacity	1,568 cm <sup>3</sup>
Type of coolant	Water
Exhaust standard level	V
Exhaust aftertreatment	DOC/DPF
Average sound power level LwA (operator's canopy)	98.1 dB(A)
Guaranteed sound power level LwA (operator's canopy)	100 dB(A)
Specified sound pressure level LpA (operator's canopy)	84 dB(A)
Average sound power level LwA (cabin)	98.1 dB(A)
Guaranteed sound power level LwA (cabin)	100 dB(A)
Specified sound pressure level LpA (cabin)	80 dB(A)

#### ■ Engine data Option 2

Engine manufacturer	Yanmar
Motor type	3TNV86CHT
Cylinder	3
Drive output	40.1 kW
Drive output	54.5 PS
at max. rpm	2,600 U/min
Cylinder capacity	1,568 cm <sup>3</sup>

Type of coolant	Water
Exhaust standard level	V
Exhaust aftertreatment	DOC/DPF
Average sound power level LwA (cabin)	97.7 dB(A)
Guaranteed sound power level LwA (cabin)	100 dB(A)
Specified sound pressure level LpA (cabin)	76 dB(A)

#### ■ Electrical system

Operating voltage	12 V
Battery	77 Ah
Alternator	80 A

#### ■ Weights

Bucket capacity (standard bucket)	0.42 m <sup>3</sup>
Operating weight	2,800 - 3,300 kg
Tipping load with bucket – machine straight, loading frame horizontal	1,910 - 2,640 kg
Tipping load with bucket – machine pivoted, loading frame horizontal	1,600 - 2,200 kg
Tipping load with pallet fork – machine straight, loading frame horizontal	1,550 - 2,140 kg
Tipping load with pallet fork – machine pivoted, loading frame horizontal	1,310 - 1,800 kg

#### ■ Driver's cab

Driver's cab	FSD (EPS, cabin)
--------------	------------------

#### ■ Filling levels

Tank capacity for fuel	50 l
Tank capacity for hydraulic oil	30 l

#### ■ Drive system

Type of drive	electronically controlled
---------------	---------------------------

drive unit	Hydrostatic via transfer gearbox and universal joint shaft
Speed levels	2
Axle	PA940
Travel speed Standard	0-20 km/h
Travel speed Option 1	0-30 km/h
Operating brake	Multi-disc brake on front axle acting on rear axle via universal joint shaft Electro-hydraulic multi-disc brakes with spring suspension in the front axle acting on rear axle via articulated universal joint shaft
Parking brake	
Differential lock	100 % front axle + rear axle

#### ■ Hydraulic system

Drive hydraulics working pressure (max.)	400 (470) bar
Work hydraulics discharge volume (max.)	41,6 (49,5-84) l/min
Work hydraulics working pressure (max.)	210 bar

#### ■ Kinematics

Kinematics type	P
Lifting cylinder	2
Tipping cylinder	1
Quick change system	hydraulic

#### ■ Steering

Steering type	hydraulically activated articulated pendulum steering
Steering cylinder	1
Oscillating angle	± 8 degree

#### ■ Other information

FSD = overhead guard  
 EPS = Easy Protection System (fold-down overhead guard)  
 DPF = diesel particulate filter  
 DOC = diesel oxidation catalyst  
 Tipping load calculation pursuant to ISO 14397

## Dimensions

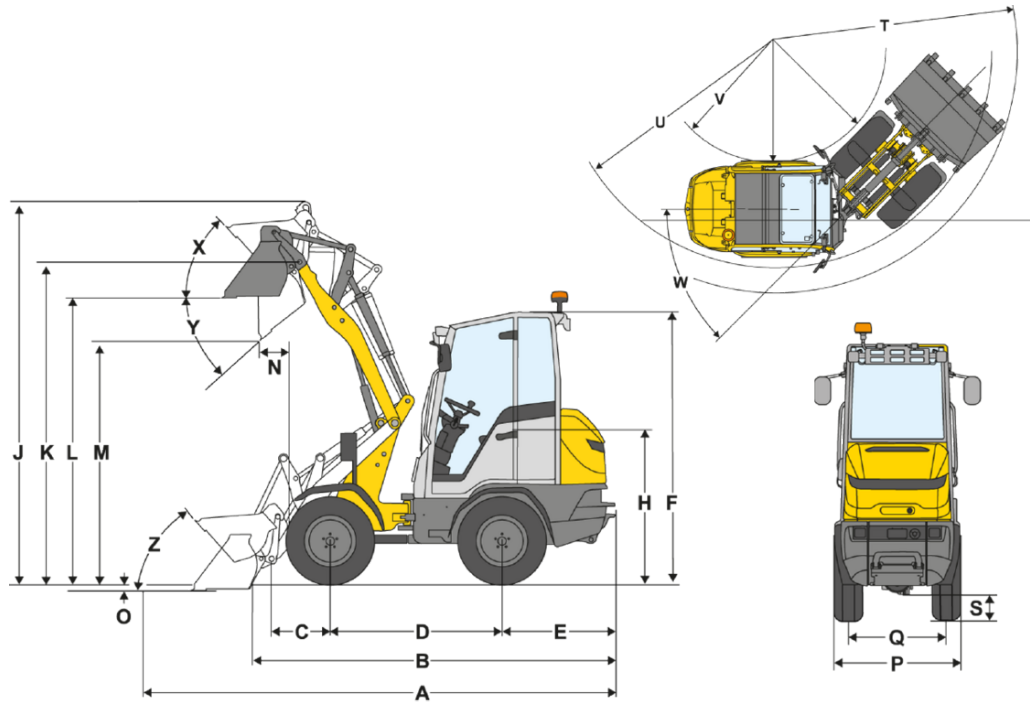

A	Total length	4,520 mm
B	Total length without bucket	3,710 mm
C	Bucket pivot point (to center of axle)	670 mm
D	Wheel base	1,760 mm
E	Rear overhang	1,230 mm
F	Height with operator's canopy (fixed)	2,340 mm
	Height with fold-down operator's canopy (EPS)	2,395 mm
	Height with fold-down operator's canopy (EPS), folded down	1,890 mm
	Height with cab	2,350 mm
H	Seat height	1,350 mm
J	Total working height	3,210 mm
K	Bucket pivot point (max. lift height)	2,560 mm
L	Load-over height	2,240 mm
M	Dumping height	1,700 mm
N	Reach (at M)	520 mm
O	Digging depth	130 mm
P	Total width	1,250 mm
Q	Track width	940 mm
S	Ground clearance	270 mm
T	Maximum radius	3,200 mm
U	Radius on the outer edge	2,800 mm
V	Inner radius	1,510 mm
W	Articulation angle	45 °
X	Rollback angle at max. lift height	47 °
Y	Dumping angle	41 °
Z	Rollback angle on ground	50 °