



WL52

Wheel Loader

Strong machine performance

Beside powerful hydraulics, the WL52 wheel loader offers extremely easy-to-use joystick pilot control. The cab is characterized by outstanding ergonomics, clear arrangement and comfort. This makes fatigue-free work possible for the operator even on long workdays. The WL52 is a powerhouse, impressive with high breakout forces and large tipping cylinders. Ideally suited for frequent material transport and many loading cycles.

Highlights

- High productivity thanks to the low front carriage
- Ergonomic cockpit
- The wheel loader as an attachment carrier
- Variety of equipment
- Joystick console spring-mounted on the operator's seat

Technical Data

Standard engine data

Engine manufacturer	Deutz
Motor type	TCD 2.9 L4 S5
Cylinder	4
Drive output	55.4 kW
Drive output	75 PS
at max. rpm	2,300 U/min
Cylinder capacity	2,900 cm ³
Type of coolant	Water/charge air
Exhaust standard level	V
Exhaust aftertreatment	DOC/DPF

Electrical system

Operating voltage	12 V
Battery	100 Ah
Alternator	85 A

Weights

Bucket capacity (standard bucket)	0.85 m ³
Operating weight	5,100 kg
Tipping load with bucket – machine straight, loading frame horizontal	3,949 kg
Tipping load with bucket – machine pivoted, loading frame horizontal	3,416 kg
Tipping load with pallet fork – machine straight, loading frame horizontal	3,055 kg

Tipping load with pallet fork – machine pivoted, loading frame horizontal 2,555 kg

Driver's cab

Driver's cab	Cab
--------------	-----

Filling levels

Tank capacity for fuel	82 l
Tank capacity for hydraulic oil	66 l

Drive system

Type of drive	Hydrostatic
drive unit	universal joint shaft
Speed levels	2
Axle	PA 1400 (PA 1422)
Travel speed Standard	0-20 km/h
Travel speed Option 1	0-30 km/h
Operating brake	Hydrostatic drive system acting on all 4 wheels (wear-free)
Parking brake	Service and parking brake in the drive train acts on all 4 wheels
Differential lock	100 % front axle + rear axle

Hydraulic system

Drive hydraulics working pressure (max.)	450 bar
Work hydraulics discharge volume (max.)	73,6 (83-115) l/min
Work hydraulics working pressure (max.)	220 bar

■ Kinematics

Kinematics type	Z
Lifting cylinder	2
Tipping cylinder	1
Quick change system	hydraulic

■ Steering

Steering type	hydraulically activated articulated pendulum steering
Steering cylinder	1

Oscillating angle	±12 degree
-------------------	------------

■ Noise characteristic values

Average sound power level L _{wA} (cabin)	99.9 dB(A)
Guaranteed sound power level L _{wA} (cabin)	101 dB(A)
Specified sound pressure level L _{pA} (cabin)	74 dB(A)

■ Other information

FSD = overhead guard
DPF = diesel particulate filter
DOC = diesel oxidation catalyst
SCR = selective catalytic reduction
Tipping load calculation pursuant to ISO 14397

Dimensions

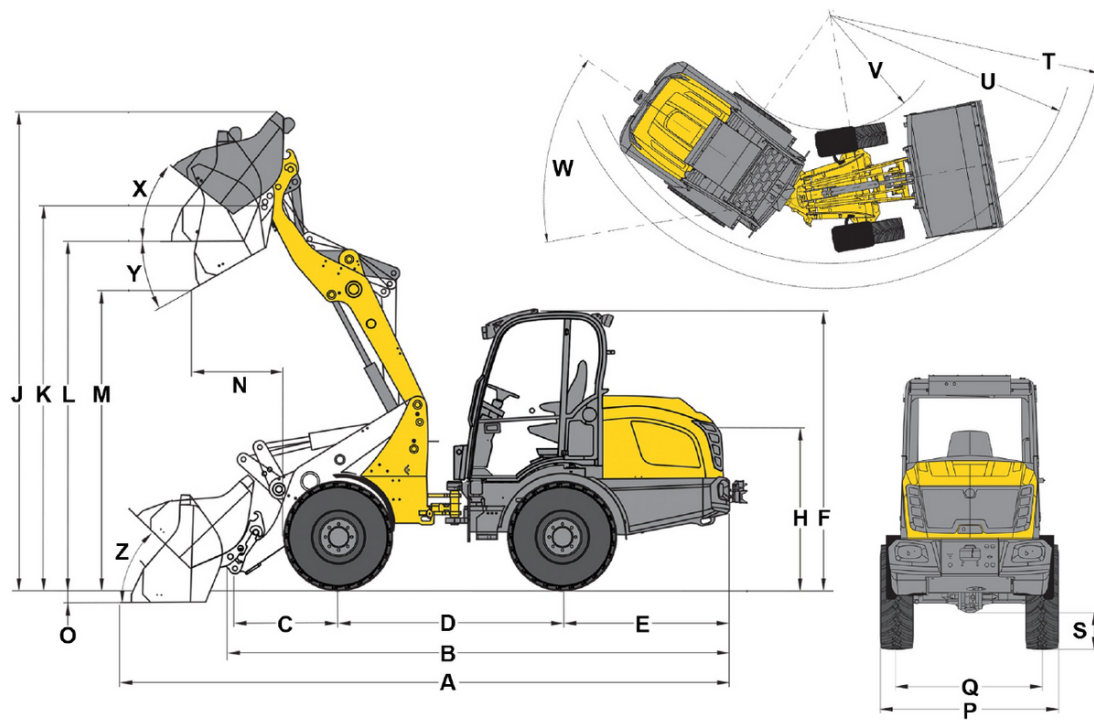

A	Total length	5,420 mm
B	Total length without bucket	4,760 mm
C	Bucket pivot point (to center of axle)	1,040 mm
D	Wheel base	2,110 mm
E	Rear overhang	1,530 mm
F	Height with cab lowered	2,498 mm
	Height with cab raised	2,680 mm
H	Seat height	1,590 mm
J	Total working height	3,930 mm
K	Bucket pivot point (max. lift height)	3,240 mm
L	Load-over height	2,980 mm
M	Dumping height	2,470 mm
N	Reach (at M)	626 mm
O	Digging depth	96 mm
P	Total width	1,810 mm
Q	Track width	1,400 mm
S	Ground clearance	370 mm
T	Maximum radius	4,240 mm
U	Radius on the outer edge	3,850 mm
V	Inner radius	1,910 mm
W	Articulation angle	40 °
X	Rollback angle at max. lift height	71 °
Y	Dumping angle	45 °
Z	Rollback angle on ground	43 °