

FERRI[®]

Offset/in-line slope mowers
for agriculture and green areas

ZMLE

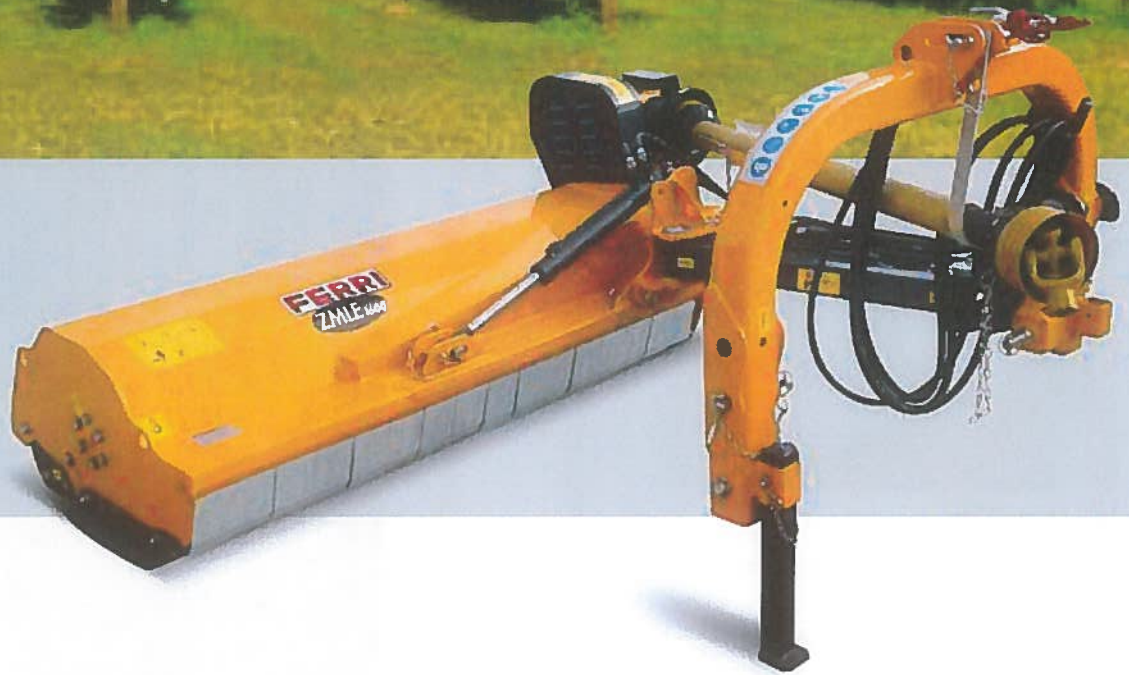



Offset/in-line slope mowers for agriculture and green areas

The innovative and patented design places the flail head axially with respect to the tractor even if the gearbox is external to the transmission. This system utilizes a three point headstock attachment with a double linkage. One machine is able to perform the work which required use of two slope mowers: you have a bigger offset and at the same time, with a simple manual operation, you can set the flail head rear and centrally to operate along the rows.

Two in one!

One machine = two slope mowers

FERRI PATENT on DOUBLE LINKAGE



RIGHT HAND LINKAGE

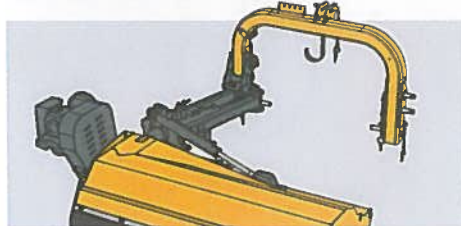

LEFT HAND LINKAGE



Gearbox unit outside the transmission cover (more offset and less PTO angle).

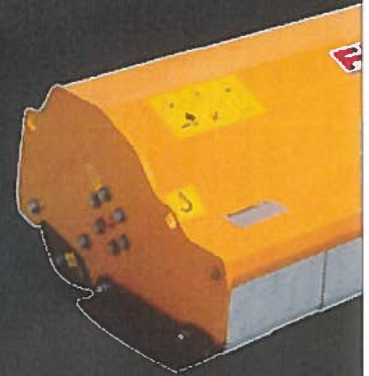

SAFETY



Hydraulic block tap for transport with manual activation (no chains or holders).



Mechanical block pin for transport (no chains or holders).



FERRI®

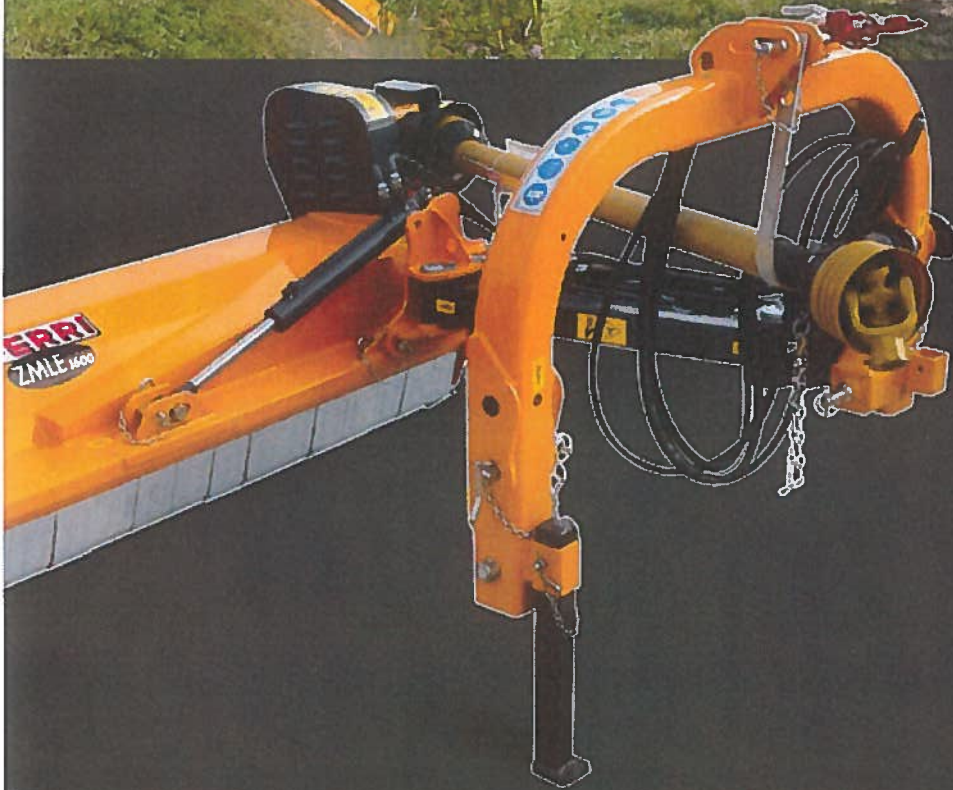

ZMLE1400

ZMLE1600

TECHNICAL



Floating frame following the ground contours.

RELIABILITY



Three point headstock attachment with a double linkage: one machine is able to perform the work which required use of two slope mowers.



Hydraulic side shift cylinder fitted within the parallel arms for better protection during work.

PERFORMANCE



Adjustable Rear Roller \varnothing 5.5".



Rotor internal sealed bearings.





Rotation joint on self lubricating bushing.



Offset/in-line slope mowers for agriculture and green areas

Technical data	ZMLE	
Model	1400	1600
Cutting width	ft 4' 8"	5' 4"
Max Sidesliding*	ft 7' 10"	8' 6"
Flail head angle	48°/90°	48°/90°
Weight	lbs 961	1005
Tractor	HP/PS 40/70	40/70
Min. Tractor weight	lbs 2886	3086
Min. Tractor width	ft 5' 11"	7' 3"
Pto	MAX Rpm 540	540
Blade tip speed	ft/sec 47	47

* Reach measured from tractor centre line to head edge

Flails	ZMLE	
Interchangeable on the same rotor	1400	1600
"Y" blades for grass, shrubs, bushes Ø max 1 1/4"	 N° 54	66
Forged hammer-blades for woods, grass, twigs Ø max 1 3/4"	 N° 18	22

Working positions (ft): right hand linkage		ZMLE1400	ZMLE1600
A	ft 7'10"	8'6"	
B	ft 5'7"	5'7"	
C	ft 4'8"	5'4"	
D	ft 0'1.6"	0'1.6"	
E	ft 5'5"	5'5"	
F	ft 4'11"	4'11"	
G	ft 3'4"	4'	
H	ft 1'4"	1'4"	

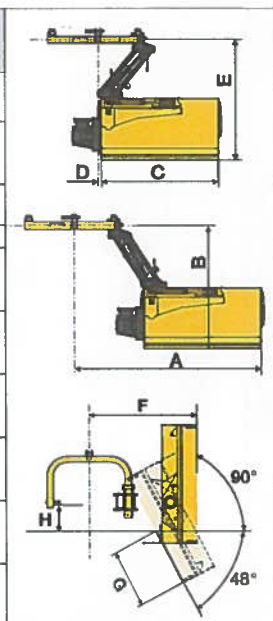

Working positions (ft): left hand linkage		ZMLE1400	ZMLE1600
A	ft 3'12"	4'8"	
B	ft 5'7"	5'7"	
C	ft 2'8"	2'8"	
D	ft 2'	2'8"	
E	ft 5'11"	5'11"	

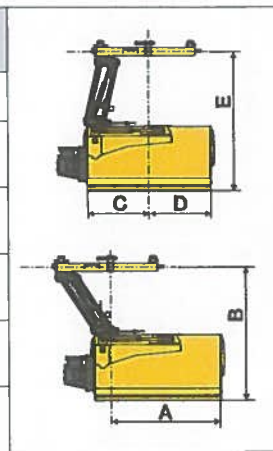

Rev.0 - 1230
campbellnh.com 61216 ZMLE - USA - EN
All data subject to change

www.ferri-america.com



FERRI srl
Via Govoni, 30
44034 Tamara (FE) Italy
Tel. +39 0532 866866
Fax +39 0532 866851
info@ferri.it - www.ferri.it



North America Sales and Marketing Manager / FERRI
Ronald E. Roglis - Glenarm, Illinois 62536
Cell (314) 422-9460 - Fax (217) 483-4123
ron.roglis@gmail.com

Parts Stock / FERRI:
J.S. Woodhouse Co., Inc. - 1314 Union Street
P.O. Box 1169 - West Springfield, Ma. 01090 U.S.A.
tel. 413-736-5462 - fax 413-732-3786
info@jswoodhouse.com



OFFSET/IN-LINE SLOPE MOWERS FOR AGRICULTURE AND GREEN AREAS

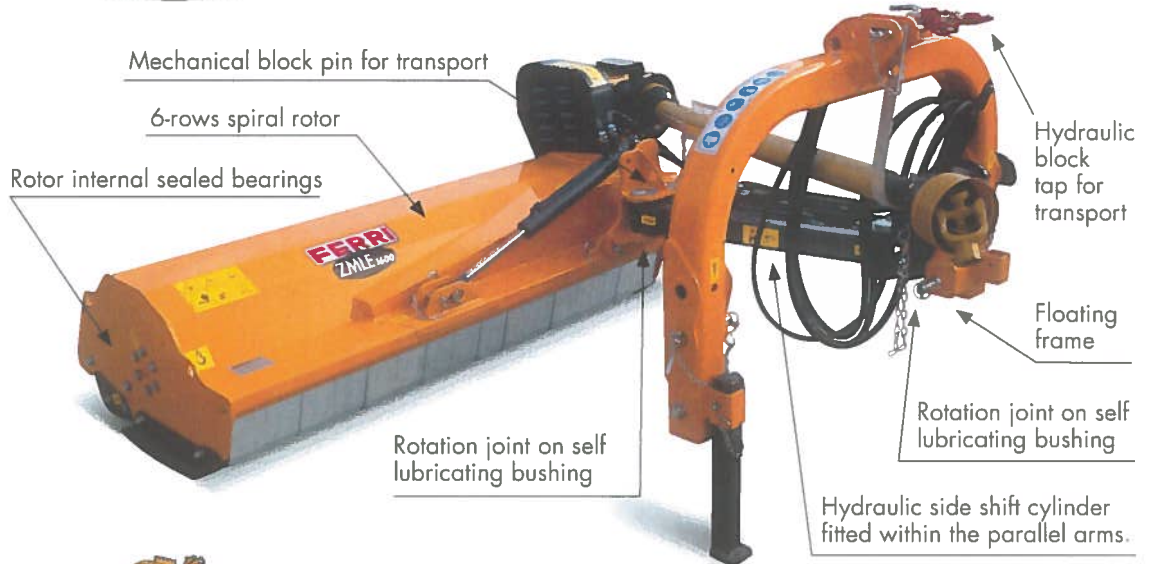

Hydraulic block tap for transport with manual activation (no chains or holders)



Mechanical block pin for transport (no chains or holders)

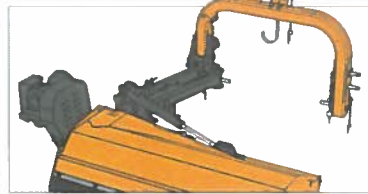
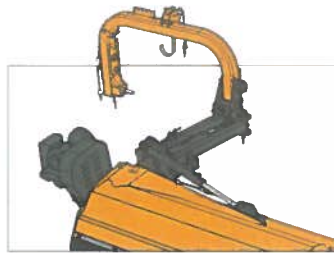

FERRI PATENT on DOUBLE LINKAGE This system utilizes a three point headstock attachment with a double linkage. One machine is able to perform the work which required use of two slope mowers.



Gearbox unit outside the transmission cover (more offset and less PTO angle).

HP Tractor	40	50	60	70	Min. tractor weight lbs	Min. tractor width ft.
ZMLE 1400	[Green bar]				2886	5'11"
ZMLE 1600	[Green bar]				3086	7'3"

Working positions: right hand linkage

	ZMLE1400	ZMLE1600
A ft	7'10"	8'6"
B ft	5'7"	5'7"
C ft	4'8"	5'4"
D ft	0'1.6"	0'1.6"
E ft	5'5"	5'5"
F ft	4'11"	4'11"
G ft	3'4"	4'
H ft	1'4"	1'4"

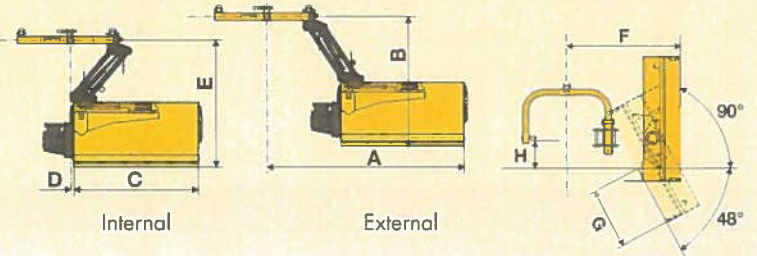

Floating frame following the ground contours



Rotation joint on self lubricating bushing



Rotor internal sealed bearings

Working positions: left hand linkage

	ZMLE1400	ZMLE1600
A ft	3'12"	4'8"
B ft	5'7"	5'7"
C ft	2'8"	2'8"
D ft	2'	2'8"
E ft	5'11"	5'11"

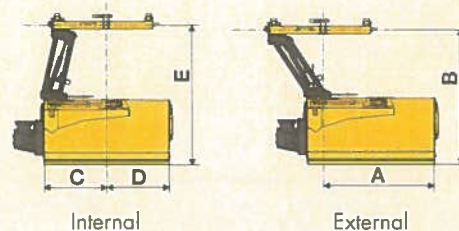

Technical data

Model	Cutting width	Max side-sliding*	Flail head angle		Weight	Three point linkage	Pto	Belts	Blade tip speed
	ft.		degrees						
ZMLE1400	4'8"	7'10"	↓ 48°	90° ↑	961	II	540	3	47
ZMLE1600	5'4"	8'6"	↓ 48°	90° ↑	1005	II	540	3	47

* Reach measured from tractor centre line to head edge.

Machines

Model	Flails	Net Distributor - \$	Suggested Retail - \$
ZMLE1400	A 54 "Y" blades	5951	10293
	B 18 Hammer blades	5913	10227
ZMLE1600	A 66 "Y" blades	6277	10857
	B 22 Hammer blades	6234	10782

Accessories at extra charge

	Net Distributor - \$	Suggested Retail - \$
Kit distributor with 2 levers and floating position	636	1100

Equipped with:

- Gearbox is fitted outside the transmission cover (more reach and less pto shaft angle)
- Double locking system for transport (this avoids accidental tilting or side movement of the flail head) no need for chains or holders
- Floating frame (the joint pin on the tractor side allows the head system to follow the ground, protecting the arm structure)
- Gearbox with free wheel
- Hydraulic side shift cylinder fitted within the parallel arms for better protection during work
- Hydraulic cylinder for head positioning
- Rotation joint and parallel arms on self lubricating bushings
- Heat treated pins
- Rotor internal sealed bearing
- Adjustable Rear Roller ø 5.5"
- Front guard with metal flaps
- Reinforced Pto Shaft
- Packing (pallet)
- Adjustable side skids

Warning:

- Suitable for tractors equipped with 1 distributor with 2 double acting sections, one of which with floating. In case the tractor has only one acting, it will be necessary to fit the kit distributor with floating (see option.)

Flails

Interchangeable on the same rotor

"Y" blades for:
grass, shrubs, bushes
Ø max 1 1/4"



A

Cod. 0901158

Forged hammer-blades for:
woods, grass, twigs
Ø max 1 3/4"



B

Cod. 0901194

- Any Ferri offset mower ZME-ZTE-ZMLE-ZMTE-ZLE-ZHE will be supplied with parallel arms partially dismantled. Reassembling as per Ferri owner's manual will be at dealer's charge
- Attachment to the tractor 3 point hitch, including PTO shaft fitting, also at dealer's charge
- Side skid kits will be supplied separately. Relevant mounting as per instructions will be at dealer's charge



ASSOCIATE MEMBER



FERRI srl

Via Govoni, 30
44034 Tamara (FE) Italy
Tel. 011 39 0532 866866
Fax 011 39 0532 866851
info@ferrisrl.it - www.ferrisrl.it



North America Sales and
Marketing Manager/FERRI

Ronald E. Roglis
Glenarm, Illinois 62536
Cell (314) 422-9460
Fax (217) 483-4123
E-mail: ron.roglis@gmail.com



J.S. Woodhouse Co., Inc.

1314 Union Street
P.O. Box 1169
West Springfield, Ma. 01090 U.S.A.
Tel. 413-736-5462
Fax 413-732-3786
E-mail: info@jswoodhouse.com