

SPECIFICATIONS

HW250MH

Tier 4 Final Engine

Net Power

SAE J1349 / 174 HP
(129.4 kW) at 2,000 rpm

Mono Boom

6.5 m (21' 4")
Arm
4.5 m (14' 9")

Operating Weight

26,100 kg (57,540 lb)

ENGINE			
Maker / Model		Cummins QSB6.7	
Type		4-cycle turbocharged, charged air, cooled diesel engine	
Rated flywheel horse power	SAE	J1995 (gross)	183 HP (136.8kW) at 2,000 rpm
		J1349 (net)	174 HP (129.4kW) at 2,000 rpm
	DIN	6271/1 (gross)	186 PS (136.8kW) at 2,000 rpm
		6271/1 (net)	176 PS (129.4kW) at 2,000 rpm
Max. torque		85.7 kg fm (620 lbf ft) / 1,500 rpm	
Bore x stroke		107 x 124 mm (4.2" x 4.9")	
Piston displacement		6700 cc (409 in ³)	
Batteries		2 x 12 V x 100 Ah	
Starting motor		Denso 24 V - 4.8 kW	
Alternator		Denso 24 V - 95 Amp	

HYDRAULIC SYSTEM	
MAIN PUMP	
Type	Variable displacement tandem axis piston pumps
Max. flow	2 x 234 l/min (61.8 gpm)
Sub-pump for pilot circuit (Gear Pump)	25.5 l/min (6.7 gpm)

CROSS-SENSING AND FUEL-SAVING PUMP SYSTEM	
HYDRAULIC MOTORS	
Travel	Two speed axial pistons motor with brake valve and parking brake
Swing	Axial piston motor with automatic brake

RELIEF VALVE SETTING	
Implement circuits	350 kgf/cm ² (4,980 psi)
Travel	380 kgf/cm ² (5,400 psi)
Power boost (boom, arm, bucket)	380 kgf/cm ² (5,400 psi)
Swing circuit	265 kgf/cm ² (3,770 psi)
Pilot circuit	40 kgf/cm ² (570 psi)
Service valve	Installed

HYDRAULIC CYLINDERS	
No. of cylinder bore X stroke	Boom: 120 x 1,290 mm
	Arm: 140 x 1,510 mm
	Outrigger: 130 x 427 mm

DRIVES & BRAKES	
Drive method	Fully hydrostatic type
Drive motor	Axial piston motor, in-shoe design
Reduction system	Planetary reduction gear
Max. drawbar pull	11,600 kgf (25,570 lbf)
Max. travel speed (high / low)	35 km/h (21.7 mph) / 9.1 km/h (5.65 mph)
Gradeability	33° (65%)

Service Brake :

- Independent dual brake, front and rear axle full hydraulic power brake.
- Spring released and hydraulic applied wet type multiple disc brake.

Parking Brake :

- Spring applied and hydraulic released wet disc brake type in transmission.



CONTROL	
Pilot pressure operated joysticks and pedals with detachable lever provide almost effortless and fatigueless operation.	
Pilot control	Two joysticks with one safety lever (LH): Swing and arm, Boom and bucket (RH): Boom and bucket (ISO)
Traveling and steering	Two levers with pedals
Engine throttle	Electric, Dial type

OPERATING WEIGHT (APPROXIMATE)	
Operating weight including 6.5 m (21' 4") Straight boom, 4.5 m (14' 9") Gooseneck arm, 0.60 m ³ (0.78 yd ³), Lubricant, Coolant, Full Fuel Tank and Hydraulic Tank and etc.	

OPERATING WEIGHT	
Front and rear outrigger	26,100 kg (57,540 lb)
Front and rear outrigger with orange grappler	27,500 kg (60,630 lb)

SWING SYSTEM	
Swing motor	Fixed displacement axial piston motor
Swing reduction	Planetary gear reduction
Swing bearing lubrication	Grease-bathed
Swing brake	Multi wet disc
Swing speed	9.7 rpm

SERVICE REFILL CAPACITIES			
Re-filling	liter	US gal	
Fuel tank	310.0	81.9	
Engine coolant	40	10.6	
Engine oil	23.7	6.3	
Swing device	6.2	1.6	
Axle	Front	14.6	3.9
	Rear	18.5	4.9
Hydraulic system (including tank)	340.0	89.8	
Hydraulic tank	165.0	43.6	
DEF/AdBlue®	27	7.1	

UNDERCARRIAGE	
Reinforced box-section frame is all-welded, low-stress.	
Front and Rear Outriggers	Indicated for max. operation stability when digging and lifting.

SPECIFICATIONS HW250 MH

Tier 4 Final Engine

HW250 MH DIMENSIONS

Unit: mm (ft-in)

6.5 m (21' 4") Mono boom, 4.5 m (14' 9") Gooseneck Arm

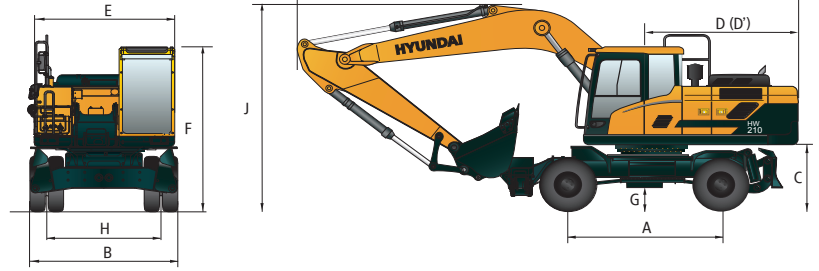

A	Wheel base	2,800	(9' 2")
B	Short Axle	2,530	(8' 4")
	Wide Axle (Standard)	2,700	(8' 10")
C	Ground clearance of counterweight	1,300	(4' 3")
D	Rear-end distance	2,840	(9' 4")
D'	Rear-end swing radius	2,913	(9' 7")
E	Upperstructure width	2,530	(8' 4")
F	Overall height of cab	3,245	(10' 8")
G	Min. ground clearance	353	(1' 2")
H	Tread	1,914	(6' 3")

	Boom length	6,500	(21' 4")
	Arm length	4,500	(14' 9")
I	Overall length (Shipping position)	9,730	(31' 11")
J	Overall height of boom (Traveling position)	3,200	(10' 6")
K	Overall height of guardrail	3,460	(11' 4")

HW250 MH WORKING RANGE

Unit : mm (ft-in)

	Boom length	6,500 (21' 4")	
	Arm length	Gooseneck Arm	Straight Arm (Optional)
		4,500 (14' 9")	4,000 (13' 1")
A	Max. digging reach	10,700 (35' 1")	10,400 (34' 1")
B	Max. digging depth	4,700 (15' 5")	4,200 (13' 9")
D	Max. digging height	12,000 (39' 4")	12,000 (39' 4")
F	Min. swing radius (without grappler)	2,700 (8' 10")	2,700 (8' 10")
F'	Min. swing radius (without grappler)	3,000 (9' 10")	3,000 (9' 10")

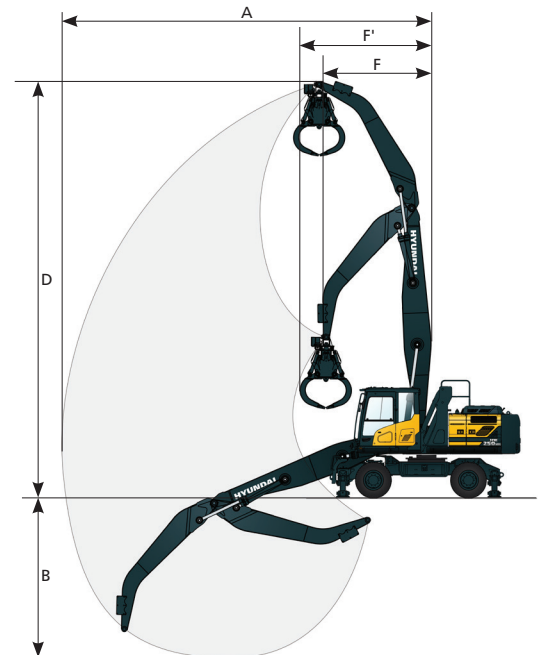

SPECIFICATIONS HW250 MH

Tier 4 Final Engine

- RATING OVER FRONT
- () RATING OVER SIDE

HW250 MH GOOSENECK ARM													
6.5 m (21' 4") Mono boom, 4.5 m (14' 9") Arm													
	12 m (39.3 ft)	11 m (36 ft)	10 m (32.8 ft)	9 m (29.5 ft)	8 m (32.8 ft)	7 m (22.9 ft)	6 m (19.6 ft)	5 m (16.4 ft)	4 m (13.1 ft)	3 m (9.8 ft)	2 m (6.5 ft)	1 m (3.2 ft)	0 m/ft
13 m (42.6 ft)													
12 m (39.3 ft)													
11 m (36 ft)								12,873 (12,873)					
10 m (32.8 ft)					9,360 (9,360)	11,331 (11,331)	12,213 (12,213)						
9 m (29.5 ft)				8,840 (8,840)	10,280 (10,280)	10,928 (10,928)	11,775 (11,775)						
8 m (26.2 ft)					9,581 (9,581)	10,152 (10,152)	10,857 (10,857)	11,735 (11,735)					
7 m (22.9 ft)				9,014 (9,014)	9,576 (9,576)	10,251 (10,251)	11,069 (11,069)	12,075 (12,075)					
6 m (19.6 ft)		7,186 (7,186)	9,041 (9,041)	9,722 (9,722)	10,535 (10,535)	11,539 (11,539)	12,802 (12,802)						
5 m (16.4 ft)		8,441 (7,552)	9,157 (9,078)	9,971 (9,971)	10,979 (10,979)	12,220 (12,220)	13,894 (13,894)	16,207 (16,207)					
4 m (13.1 ft)		8,478 (7,455)	9,314 (8,092)	10,280 (10,280)	11,481 (11,481)	13,054 (13,054)	15,243 (15,243)	18,548 (18,548)	24,092 (24,092)				
3 m (9.8 ft)		8,505 (7,334)	9,470 (8,710)	10,591 (10,505)	12,011 (12,011)	13,920 (13,920)	16,670 (16,670)	21,042 (21,042)					
2 m (6.5 ft)		8,478 (7,213)	9,574 (8,516)	10,842 (10,218)	12,454 (12,454)	14,641 (14,641)	17,861 (17,861)	23,003 (23,003)					
1 m (3.2 ft)		8,346 (7,105)	9,570 (8,339)	10,965 (9,958)	12,721 (12,154)	15,091 (15,091)	18,529 (18,529)	22,134 (22,134)					
0 Line		8,037 (7,023)	9,400 (8,198)	10,893 (9,746)	12,734 (11,858)	15,159 (14,886)	18,632 (18,632)	22,134 (22,134)	18,632 (18,632)	11,062 (11,062)			
-1 m (-3.2 ft)		7,457 (6,985)	8,990 (6,985)	10,555 (9,601)	12,416 (11,653)	14,785 (14,624)	17,949 (17,949)	18,264 (18,264)	12,469 (12,469)				
-2 m (-6.5 ft)			8,251 (8,079)	9,887 (9,532)	11,704 (11,543)	13,922 (13,922)	16,721 (16,721)	18,963 (18,963)	14,006 (14,006)				
-3 m (-9.8 ft)													
-4 m (-13.1 ft)													
-5 m (-16.4 ft)													

NOTES:

- Lifting capacity is based on SAE J1097, ISO 10567. *Without Grappler.*
- Load point is the end pin point of front attachment.
- Lifting capacity does not exceed 75% of tipping load or 87% of hydraulic capacity.
- Lifting capacity is based on 350k system pressure therefore boost condition may have more lifting force.

SPECIFICATIONS HW250 MH

Tier 4 Final Engine

ENGINE	STD	OPT
Cummins QSB 6.7 engine	•	
HYDRAULIC SYSTEM	STD	OPT
Intelligent Power Control (IPC)		
3-power mode, 2-work mode, user mode	•	
Variable Power Control	•	
Pump Flow Control	•	
Attachment Mode Flow Control	•	
Engine Auto Idle	•	
Engine Auto Shutdown Control		•
Electronic Fan Control	•	
CAB & INTERIOR	STD	OPT
ISO Standard cabin		
Rise-up type windshield wiper	•	
Radio / USB player	•	
Handsfree mobile phone system with USB	•	
12 volt power outlet (24V DC to 12V DC converter)	•	
Electric horn	•	
All-weather steel cab with 360°visibility	•	
Safety glass windows	•	
Sliding fold-in front window	•	
Sliding side window(LH)	•	
Lockable door	•	
Hot & cool box	•	
Storage compartment & Ashtray	•	
Transparent cabin roof-cover	•	
Sun visor	•	
Door and cab locks, one key	•	
Mechanical suspension seat with heater	•	
Pilot-operated slidable joystick	•	
Console box height adjust system	•	
Automatic climate control		
Air conditioner & heater	•	
Defroster	•	
Starting Aid (air grid heater) for cold weather	•	
Centralized monitoring		
8" LCD display	•	
Engine speed or Trip meter/Accel.	•	
Engine coolant temperature gauge	•	
Max power	•	
Low speed/High speed	•	
Auto idle	•	
Overload	•	
Check Engine	•	
Air cleaner clogging	•	
Indicators	•	
ECO Gauges	•	
Fuel level gauge	•	
Hyd. oil temperature gauge	•	
Fuel warmer	•	
Warnings	•	
Communication error	•	
Low battery	•	
Clock	•	
Cabin lights		•
Cabin front window rain guard		•
Cabin roof-steel cover		•

CAB & INTERIOR	STD	OPT
Seat		
Adjustable air suspension seat with heater	•	
Cabin FOPS/FOG		
FOPS (Falling Object Protective Structures)ISO 3449 Level 2		•
FOG (Falling Object Guard)		•
Cabin ROPS		
ROPS (Roll Over Protective Structures)	•	
SAFETY	STD	OPT
Battery master switch	•	
Rearview camera		•
AAVM (Advanced Around View Monitoring)		•
Four front working lights (2 boom mounted, 2 front frame mounted)	•	
Travel alarm		•
Rear work lamp		•
Beacon lamp		•
Automatic swing brake	•	
Boom holding system		•
Arm holding system		•
Safety lock valve for boom cylinder with overload warning device		•
Safety lock valve for arm cylinder		•
Swing Lock System		•
Four outside rearview mirror	•	
OTHER	STD	OPT
Booms		
6.5 m (21' 4") Mono boom	•	
Arms		
4.0 m (13' 1") Straight		•
4.5 m (14' 9") Gooseneck	•	
Removable clean-out dust net for cooler	•	
Removable reservoir tank	•	
Fuel pre-filter	•	
Fuel warmer	single	•
	dual	•
Self-diagnostics system	•	
Hi-mate (Remote Management System)	Mobile	•
	Satellite	•
Batteries (2 x 12V x 100 AH)	•	
Fuel filler pump (50 L/min)		•
Double-acting piping kit (clamshell, etc.)	•	
Rotating Piping Kit	•	
Quick coupler piping		•
Quick coupler		•
Accumulator for lowering work equipment	•	
Pattern change valve (2 patterns)	•	
Fine Swing Control System		•
Tool kit		•
Travel pedal (2way)		•
UNDERCARRIAGE	STD	OPT
Front and rear outrigger	•	
Tires-dual (10.00-20-16PR tube)	•	
Tires-dual (10.00-20 solid)		•

* Standard and optional equipment may vary. Contact your Hyundai dealer for more information.
 The machine may vary according to International standards.
 * The photos may include attachments and optional equipment that are not available in your area.
 * Materials and specifications are subject to change without advance notice.
 * All imperial measurements rounded off to the nearest pound or inch.



www.hceamericas.com
 6100 Atlantic Blvd., Norcross, GA 30071
 TEL (678) 823 7777 FAX (678) 823 7778

PLEASE CONTACT