

SPECIFICATIONS

HX300LR

Tier 4 Final Engine

Net Power

SAE J1349 / 230 HP
(171 kW) at 1,950 rpm

Bucket Range

0.52 m³ (0.68 yd³)

Operating Weight

33,070 kg / 72,910 lb

ENGINE	
Make / model	Cummins QSB6.7
Type	4-cycle turbocharged, charge air-cooled, diesel engine
Rated flywheel horsepower	J1995 (gross) 242 HP (180 kW) at 1,950 rpm SAE J1349 (net) 230 HP (171 kW) at 1,950 rpm
Max. torque	100.9 kgf-m (729.8 lbf-ft) at 1,500 rpm
Bore X stroke	107 x 124 mm (4.21" x 4.88")
Piston displacement	6,700 cc (409 in ³)
Batteries	2 x 12 V x 160 Ah
Starting motor	24 V - 4.8 kW
Alternator	24 V - 95 A

HYDRAULIC SYSTEM	
MAIN PUMP	
Type	Variable-displacement tandem axis piston pumps
Max. flow	2 x 273 ℓ/min (72.1 gpm)
Sub-pump for pilot circuit	Gear pump

CROSS-SENSING AND FUEL-SAVING PUMP SYSTEM	
HYDRAULIC MOTORS	
Travel	Variable-displacement axial piston motor
Swing	Axial piston motor

RELIEF VALVE SETTING	
Implement circuits	350 kgf/cm ² (4,980 psi)
Travel	350 kgf/cm ² (4,980 psi)
Boom	400 kgf/cm ² (5,690 psi)
Arm	250 kgf/cm ² (3,560 psi)
Bucket	270 kgf/cm ² (3,840 psi)
Swing circuit	300 kgf/cm ² (4,270 psi)
Pilot circuit	40 kgf/cm ² (570 psi)
Service valve	Installed

HYDRAULIC CYLINDERS	
No. of cylinders bore X stroke	Boom: 140 x 1,465 mm (5.5" x 57.7") Arm: 150 x 1,765 mm (5.9" x 69.5") Bucket: 135 x 1,185 mm (5.3" x 46.7")

DRIVES & BRAKES	
Drive method	Fully hydrostatic type
Drive motor	Axial piston motor, in-shoe design
Reduction system	Planetary reduction gear
Max. drawbar pull	26,500 kgf (58,420 lbf)
Max. travel speed (high / low)	5.9 km/hr (3.67 mph) / 3.3 km/hr (2.05 mph)
Gradeability	35° (70%)
Parking brake	Multi wet disc brake

CONTROL	
Pilot pressure operated joysticks and pedals provide very-low-effort operation.	
Pilot control	Two joysticks with one safety lever (LH): Swing and arm (RH): Boom and bucket (ISO)
Traveling and steering	Two levers with pedals
Engine throttle	Electric, dial type



OPERATING WEIGHT (APPROXIMATE)
Operating weight, including 10.2 m (33' 6") boom, 7.85 m (25' 9") arm, SAE heaped 0.52 m³ (0.68 yd³) bucket, lubricant, coolant, full fuel tank, full hydraulic tank, 7,000 kg (15,450 lb) counterweight and all standard equipment.

OPERATING WEIGHT				
Shoes	Operating weight		Ground pressure	
Type	Width mm (in)		kg (lb)	kgf/cm ² (psi)
Triple grouser	800 (32")	HX300LR	33,070 (72,910)	0.48 (6.83)

SWING SYSTEM	
Swing motor	Fixed displacement axial piston motor
Swing reduction	Planetary gear reduction
Swing bearing lubrication	Grease-bathed
Swing brake	Multi wet disc brake
Swing speed	10.2 rpm

SERVICE REFILL CAPACITIES		
Refilling	liters	US gal
Fuel tank	500	132
Engine coolant	40	10.6
Engine oil	23	6.1
Swing device	11	2.9
Final drive (each)	7.8	2.06
Hydraulic system (including tank)	330	87
Hydraulic tank	190	50
DEF/AdBlue®	42.5	11.2

UNDERCARRIAGE	
Center frame	X-leg type
Track frame	Pentagonal box type
No. of shoes on each side	48 EA
No. of carrier rollers on each side	2 EA
No. of track rollers on each side	9 EA
No. of rail guards on each side	2 EA

SPECIFICATIONS HX300LR

Tier 4 Final Engine

HX300LR DIMENSIONS

Unit: mm (ft-in)

10.2 m (33' 6") boom and 7.85 m (25' 9") arm

A	Overall length	14,560 (47' 9")
B	Overall width, with 800 mm shoe	3,400 (11' 2")
C	Overall height of boom	3,560 (11' 8")
D	Superstructure width	2,980 (9' 9")
E	Overall height of cab	3,030 (9' 11")
F	Ground clearance of counterweight	1,190 (3' 11")
G	Overall height of engine hood	2,600 (8' 6")
G'	Overall height of handrail	3,340 (10' 11")
H	Minimum ground clearance	500 (1' 8")

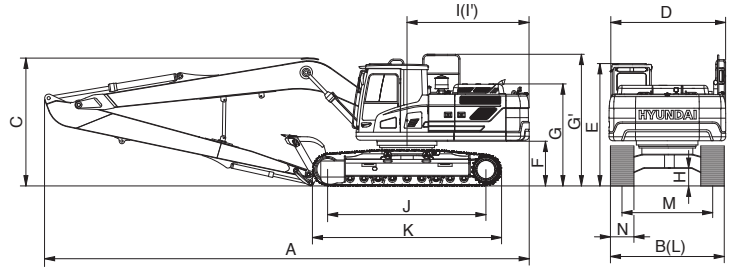

290F2SP04

I	Rear-end distance	3,120 (10' 3")
I'	Rear-end swing radius	3,200 (10' 6")
J	Distance between tumblers	4,030 (13' 3")
K	Undercarriage length	4,885 (16' 8")
L	Undercarriage width	3,400 (11' 2")
M	Track gauge	2,600 (8' 6")
N	Track shoe width, standard	800 (31' 5")

HX300LR WORKING RANGE

Unit : mm (ft-in)

A	Max. digging reach	18,510 (60' 9")
A'	Max. digging reach on ground	18,400 (60' 4")
B	Max. digging depth	14,820 (48' 7")
B'	Max. digging depth (8' level)	14,690 (48' 2")
C	Max. vertical wall digging depth	12,020 (39' 5")
D	Max. digging height	14,500 (47' 7")
E	Max. dumping height	12,190 (40' 0")
F	Min. swing radius	6,250 (20' 6")

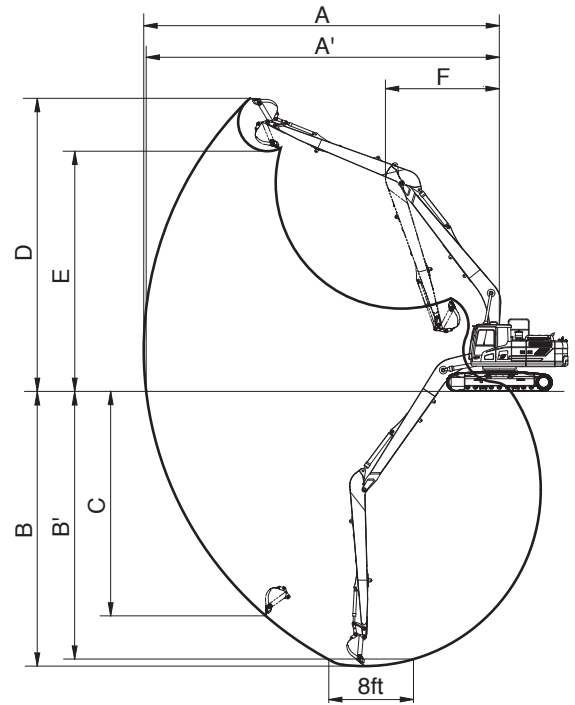

DIGGING FORCE

Boom	Length	mm (ft-in)	10,200 (33' 5")
	Weight	kg (lb)	2,980 (6,570)
Arm	Length	mm (ft-in)	7,850 (25' 9")
	Weight	kg (lb)	1,340 (2,960)
Bucket digging force	SAE	kN	70
		kgf	7,100
		lbf	15,650
	ISO	kN	80
		kgf	8,200
		lbf	18,080
Arm crowd force	SAE	kN	47.1
		kgf	4,800
		lbf	10,580
	ISO	kN	48.1
		kgf	4,900
		lbf	10,800

Note : Boom weight includes arm cylinder, piping, and pin
Arm weight includes bucket cylinder, linkage, and pin

SPECIFICATIONS HX300LR

Tier 4 Final Engine

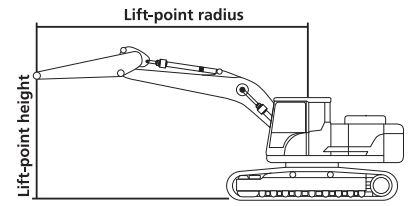

Lifting Capacity

Boom: 10.2 m (33' 6")

Arm: 7.85 m (25' 9")

Bucket: 0.52 m³ (0.68 yd³) SAE heaped

Shoe 800 mm (32") triple grouser, CWT 5,600 kg (12,350 lb)

Capacities based on North American Standard Configuration in accordance with ISO condition 2 standard.



Rating over-front



Rating over side or 360 degree

Load point height (m / ft)		Lift-point radius												At max. reach		
		1.0 m (3.3 ft)		4.0 m (13.1 ft)		7.0 m (23.0 ft)		10.0 m (32.8 ft)		13.0 m (42.7 ft)		16.0 m (52.5 ft)		Capacity		Reach
																m (ft)
12.0 m	kg													*1,320	*1,320	14.10
39.4 ft	lb													*2,910	*2,910	(46.2)
10.5 m	kg													*1,280	*1,280	15.05
34.4 ft	lb													*2,820	*2,820	(49.4)
9.0 m	kg													*1,260	*1,260	15.81
29.5 ft	lb													*2,780	*2,780	(51.9)
7.5 m	kg									*2,410	*2,410	*1,630	*1,630	*1,260	*1,260	16.39
24.6 ft	lb									*5,310	*5,310	*3,590	*3,590	*2,780	*2,780	(53.8)
6.0 m	kg									*2,590	*2,590	*2,000	1,970	*1,270	*1,270	16.82
19.7 ft	lb									*5,710	*5,710	*4,410	4,340	*2,800	*2,800	(55.2)
4.5 m	kg									*2,810	*2,810	*2,290	1,920	*1,300	*1,300	17.10
14.8 ft	lb									*6,190	*6,190	*5,050	4,230	*2,870	*2,870	(56.1)
3.0 m	kg			*9,450	*9,450	*4,950	*4,950	*3,640	*3,640	*3,050	2,730	*2,540	1,850	*1,350	*1,350	17.25
9.8 ft	lb			*20,830	*20,830	*10,910	*10,910	*8,020	*8,020	*6,720	6,020	*5,600	4,080	*2,980	*2,980	(56.6)
1.5 m	kg			*4,140	*4,140	*6,000	*6,000	*4,120	3,900	*3,300	2,590	*2,740	1,780	*1,410	*1,410	17.27
4.9 ft	lb			*9,130	*9,130	*13,230	*13,230	*9,080	8,600	*7,280	5,710	*6,040	3,920	*3,110	*3,110	(56.7)
0.0 m	kg			*3,500	*3,500	*6,900	5,860	*4,570	3,640	*3,550	2,460	2,840	1,720	*1,500	*1,500	17.15
0.0 ft	lb			*7,720	*7,720	*15,210	12,920	*10,080	8,020	*7,830	5,420	6,260	3,790	*3,310	*3,310	(56.3)
-1.5 m	kg	*2,140	*2,140	*3,890	*3,890	*7,580	5,470	*4,970	3,430	*3,780	2,340	2,790	1,670	*1,620	1,510	16.90
-4.9 ft	lb	*4,720	*4,720	*8,580	*8,580	*16,710	12,060	*10,960	7,560	*8,330	5,160	6,150	3,680	*3,570	3,330	(55.4)
-3.0 m	kg	*2,960	*2,960	*4,630	*4,630	*8,050	5,240	*5,280	3,270	3,710	2,250	*2,610	1,630	*1,770	1,550	16.51
-9.8 ft	lb	*6,530	*6,530	*10,210	*10,210	*17,750	11,550	*11,640	7,210	8,180	4,960	*5,750	3,590	*3,900	3,420	(54.2)
-4.5 m	kg	*3,830	*3,830	*5,570	*5,570	*8,320	5,110	5,240	3,170	3,650	2,200			*1,970	1,620	15.96
-14.8 ft	lb	*8,440	*8,440	*12,280	*12,280	*18,340	11,270	11,550	6,990	8,050	4,850			*4,340	3,570	(52.4)
-6.0 m	kg	*4,750	*4,750	*6,670	*6,670	*8,400	5,080	5,190	3,120	3,620	2,170			*2,250	1,740	15.25
-19.7 ft	lb	*10,470	*10,470	*14,700	*14,700	*18,520	11,200	11,440	6,880	7,980	4,780			*4,960	3,840	(50.0)
-7.5 m	kg	*5,750	*5,750	*7,970	*7,970	*8,290	5,120	5,190	3,120	3,640	2,190			*2,660	1,930	14.34
-24.6 ft	lb	*12,680	*12,680	*17,570	*17,570	*18,280	11,290	11,440	6,880	8,020	4,830			*5,860	4,250	(47.1)
-9.0 m	kg	*6,850	*6,850	*9,520	*9,520	*7,980	5,220	5,250	3,180	3,720	2,260			*3,320	2,220	13.20
-29.5 ft	lb	*15,100	*15,100	*20,990	*20,990	*17,590	11,510	11,570	7,010	8,200	4,980			*7,320	4,890	(43.3)
-10.5 m	kg	*8,080	*8,080	*11,460	*11,460	*7,410	5,400	*5,040	3,300					*4,020	2,690	11.76
-34.4 ft	lb	*17,810	*17,810	*25,260	*25,260	*16,340	11,900	*11,110	7,280					*8,860	5,930	(38.6)
-12.0 m	kg			*10,540	*10,540	*6,430	5,670							*4,270	3,580	9.88
-39.4 ft	lb			*23,240	*23,240	*14,180	12,500							*9,410	7,890	(32.4)

NOTES:

- Lifting capacities are based on ISO 10567.
- Lifting capacity of the HX Series does not exceed 75% of tipping load with the machine on firm, level ground or 87% of full hydraulic capacity.
- The Lift-point is bucket pivot mounting pin on the arm (without bucket mass).
- (*) indicates load limited by hydraulic capacity.

SPECIFICATIONS HX300LR

Tier 4 Final Engine

ENGINE	STD	OPT
Cummins QSB 6.7 engine	•	
HYDRAULIC SYSTEM		
Intelligent Power Control (IPC)		
3-power mode, 2-work mode, user mode	•	
Variable power control	•	
Pump flow control	•	
Attachment mode flow control	•	
Engine auto idle	•	
Engine auto shutdown control		•
Electronic fan control	•	
CAB & INTERIOR		
ISO standard cabin		
Rise-up type windshield wiper	•	
Radio / USB player	•	
Bluetooth / hands-free mobile phone system with USB	•	
Miracast	•	
12-volt power outlet (24 V DC to 12 V DC converter)	•	
Electric horn	•	
All-weather steel cab with 360° visibility	•	
Safety glass windows	•	
Sliding fold-in front window	•	
Sliding side window (LH)	•	
Lockable door	•	
Hot and cool box	•	
Storage compartment and ashtray	•	
Transparent cabin roof-cover	•	
Sun visor	•	
Door and cab locks, one key	•	
Mechanical suspension seat with heater	•	
Pilot-operated adjustable joystick	•	
Console box height adjust system	•	
Cabin lights	•	
Cabin front window rain guard		•
Cabin roof-steel cover		•
Automatic climate control		
Air conditioner and heater	•	
Defroster	•	
Starting aid (air grid heater) for cold weather	•	
Centralized monitoring		
8" LCD display	•	
Engine speed or trip meter / accel.	•	
Engine coolant temperature gauge	•	
Max. power	•	
Low speed / high speed	•	
Auto idle	•	
Overload		•
Check engine	•	
Air cleaner clogging	•	
Indicators	•	
ECO gauges	•	
Fuel level gauge	•	
Hydraulic oil temperature gauge	•	
Fuel warmer	•	
Warnings	•	
Communication error	•	
Low battery	•	
Clock	•	

CAB & INTERIOR	STD	OPT
Seat		
Adjustable air suspension seat with heater	•	
Cabin FOPS/FOG		
FOG ISO 10262 Level 2	Front and top guard	•
(FOPS ISO 3449 Level 2)	Top guard	•
Cabin ROPS		
ROPS ISO 12117-2	•	
SAFETY		
Battery master switch	•	
Rearview camera	•	
AAVM (All-Around View Monitoring)		•
Six front working lights (4 boom mounted, 2 front frame mounted)	•	
Dual boom working lights	•	
Travel alarm	•	
Rear work lamp		•
Beacon lamp - LED		•
Automatic swing brake	•	
Boom holding system	•	
Arm holding system	•	
Safety lock valve for boom cylinder with overload warning device		•
Safety lock valve for arm cylinder		•
Swing lock system		•
Three outside rearview mirrors	•	
OTHER		
Booms		
10.2 m, 33' 6" Long reach	•	
Arms		
7.85 m, 25' 9" Long reach	•	
Removable clean-out dust net for cooler	•	
Removable reservoir tank	•	
Fuel pre-filter	•	
Duel fuel warmer		•
Self-diagnostics system	•	
Hi-mate remote management system	Mobile Satellite	•
Batteries (2 x 12 V x 160 Ah)	•	
Fuel-filler pump (50 ℓ/min / 13 gpm)		•
One-pedal straight travel system		•
Pilot accumulator	•	
Pattern-change valve (SAE and ISO)	•	
UNDERCARRIAGE		
Lower frame under cover (normal)	•	
Track shoes		
Triple grouser shoes (800 mm, 32")	•	
Triple grouser shoes (900 mm, 36")		•
Track rail guard	•	

NOTE: Standard and optional equipment may vary. Materials and specifications are subject to change without advance notice. Contact your Hyundai dealer for more information.

PLEASE CONTACT



www.hceamericas.com
6100 Atlantic Blvd., Norcross, GA 30071
TEL (678) 823 7777 FAX (678) 823 7778