

SPECIFICATIONS

HX350AL

Powered By Cummins Performance Series Engine

Net Power
304 HP (227 kW)
at 2,100 rpm

Standard Bucket
1.44 m³(1.88 yd³)

Operating Weight
35,010 kg (77,184 lb) -
37,800 kg (83,330 lb)



ENGINE	
Maker / Model	Cummins L9
Type	Tier 4F/ Stage V Emission Certified, 6 cylinder diesel engine with No Manual Regeneration.
Gross Power (SAE J1995)	310 HP (231 kW) at 2,100 rpm
Net Power (SAE J1349)	304 HP (227 kW) at 2,100 rpm
Max. Power	325 HP (242 kW) at 1,800 rpm
Peak Torque	1126 lb-ft (1,526 N-m) at 1,400 rpm
Displacement	8,900 cc (543 cu in)

HYDRAULIC SYSTEM	
MAIN PUMP	
Type	Variable displacement piston pumps
Max. Flow	2 × 277.2 l/min (73.2 U.S. gpm)
Sub-Pump For Pilot Circuit	Gear pump
Cross-sensing and fuel saving pump system	

AUXILIARY PRESSURE		
2 Way	Flow (l/min)	26.4 gpm / (100 lpm)
	Pressure (bar)	2,611 psi / (180 bar)
Rotating	Flow (l/min)	15.9 gpm / (60 lpm)
	Pressure (bar)	4,062 psi / (280 bar)

HYDRAULIC MOTORS	
Travel	Two speed axial piston motor
Swing	Axial piston motor

RELIEF VALVE SETTING	
Implement Circuits	350 kgf/cm ² (4,980 psi)
Travel	350 kgf/cm ² (4,980 psi)
Power Boost (Boom, Arm, Bucket)	380 kgf/cm ² (5,400 psi)
Swing Circuit	300 kgf/cm ² (4,270 psi)
Pilot Circuit	40 kgf/cm ² (569 psi)
Service Valve	Installed

HYDRAULIC CYLINDERS	
No. of Cylinder Bore X Stroke	Boom: Ø 150 × 1,480 ST
	Arm: Ø 160 × 1,685 ST
	Bucket: Ø 140 × 1,285 ST

* Hyundai Bio Hydraulic Oil (HBHO) available.

DRIVES & BRAKES	
Drive Method	Fully hydrostatic type
Drive Motor	Axial piston motor, in-shoe design
Reduction System	Planetary reduction gear
Max. Drawbar Pull	27,404 kgf (60,415 lbf)
Max. Travel Speed (High / Low)	6.4 km/hr (3.98 mph) / 3.5 km/hr (2.17 mph)
Gradeability	35° (70%)
Parking Brake	Multi wet disc

CONTROL	
Pilot pressure operated joysticks and pedals with detachable lever provide almost effortless and fatigueless operation.	
Pilot Control	Two joysticks with one safety lever (LH): Swing and arm, (RH): Boom and bucket (ISO)
Traveling And Steering	Two levers with pedals
Engine Throttle	Electric, Dial type

OPERATING WEIGHT (APPROXIMATE)

Operating weight, including 6,450 mm (21' 2") boom, 3,200 mm (10' 6") arm, SAE heaped 1.44 m³(1.88 yd³) bucket, lubricant, coolant, full fuel tank, full hydraulic tank, and all standard equipments.

OPERATING WEIGHT				
Shoes		Operating Weight		Ground Pressure
Type	Width mm (in)		kg (lb)	kgf/cm ² (psi)
Triple Grouser	600 (24")	HX350AL	35,010 (77,184)	0.65 (9.22)
	700 (28")	HX350AL	35,530 (78,330)	0.57 (8.04)
	800 (32")	HX350AL	35,910 (79,670)	0.50 (7.11)
	900 (36")	HX350AL	36,300 (80,027)	0.45 (6.39)
Double Grouser	700 (28")	HX350A HW	37,800 (83,330)	0.62 (8.85)

SWING SYSTEM	
Swing Motor	Fixed Displacement Axial Piston Motor
Swing Reduction	Planetary Gear Reduction
Swing Bearing Lubrication	Grease-Bathed
Swing Brake	Multi Wet Disc
Swing Speed	10.2 rpm

COOLANT & LUBRICANT CAPACITY		
	LITER	US gal
Fuel Tank	600	154.7
Engine Coolant	55	14.5
Engine Oil	30	7.9
Swing Device	11	2.91
Final Drive (Each)	7.8	2.06
Hydraulic System (Including Tank)	414	106.7
Hydraulic Tank	210	54.1
DEF/AdBlue [®]	70	18.5

UNDERCARRIAGE	
The X-leg type center frame is integrally welded with reinforced box-section track frames. The undercarriage includes lubricated rollers, idlers, track adjusters with shock absorbing springs and sprockets, and a track chain with double or triple grouser shoes.	
Center Frame	X - Leg Type
Track Frame	Pentagonal Box Type
No. of Shoes on Each Side	48 EA
No. of Carrier Roller on Each Side	2 EA
No. of Track Roller on Each Side	9 EA
No. of Rail Guard on Each Side	2 EA

CAB NOISE LEVEL	
Guaranteed noise level presented below can be differed depending on a range of factors such as operating condition, speed of a cooling fan, types of engine and so forth. Hearing protection shall be necessary if an operator is working in the improperly aintained cabin or exposed to a noisy environment by leaving doors and/or windows open. With cooling fan speed at maximum value:	
With cooling fan speed at maximum value:	
Operator sound pressure level (ISO 6396:2008)	70 dB(A)
Exterior sound power level (ISO 6395:2008)	98 dB(A)
* Distance of 15 m (49.2 ft), moving forward in second gear ratio	

SPECIFICATIONS HX350AL

Powered By Cummins Performance Series Engine

HX350L DIMENSIONS

Unit: mm (ft-in)

6.45 m (21' 2"), 6.15 m (20' 2") boom and 2.2 m (7' 3"), 2.5 m (8' 2"), 3.2 m (10' 6"), 4.05 m (13' 3") arm

A	Tumbler distance	4,030 (13' 3")
B	Overall length of crawler	4,940 (16' 2")
C	Ground clearance of counterweight	1,200 (3' 11")
D	Tail-swing radius	3,570 (11' 7")
D'	Rear-end length	3,505 (11' 5")
E	Overall width of upper structure	2,980 (9' 9")
F	Overall height of cab	3,160 (10' 4")
G	Min. ground clearance	500 (1' 8")
H	Track gauge	2,680 (8' 10")
I	Overall height of guardrail	3,350 (11' 0")

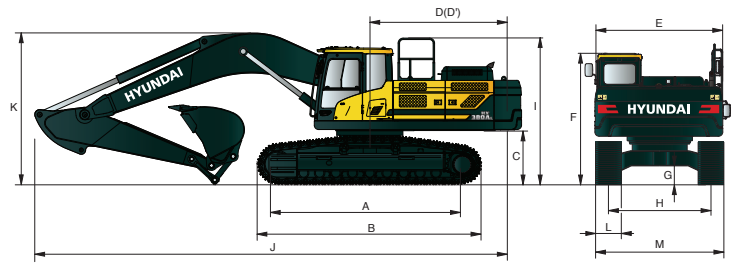

Boom length	6,150 (20' 2")	6,450 (21' 2")			
Arm length	2,200 (7' 3")	2,200 (7' 3")	2,500 (8' 2")	3,200 (10' 6")	4,050 (13' 3")
J Overall length	11,170 (36' 8")	11,470 (37' 8")	11,340 (37' 2")	11,220 (36' 10")	11,220 (36' 10")
K Overall height of boom	3,680 (12' 1")	3,740 (11' 11")	3,760 (12' 0")	3,380 (11' 1")	3,860 (12' 8")
L Track shoe width	600 (24")	700 (28")	800 (32")	900 (36")	
M Overall width	3,280 (10' 9")	3,380 (11' 1")	3,480 (11' 5")	3,580 (11' 5")	

HX350L WORKING RANGE

Unit : mm (ft-in)

Boom length	6,150 (20' 2")	6,450 (21' 2")			
Arm length	2,200 (7' 3")	2,200 (7' 3")	2,500 (8' 2")	3,200 (10' 6")	4,050 (13' 3")
A Max. digging reach	10,020 (32' 10")	10,330 (33' 11")	10,550 (34' 7")	11,140 (36' 7")	11,950 (39' 2")
A' Max. digging reach on ground	9,800 (32' 2")	10,110 (33' 2")	10,330 (33' 11")	10,940 (35' 11")	11,760 (38' 7")
B Max. digging depth	6,160 (20' 3")	6,370 (20' 11")	6,670 (21' 11")	7,370 (24' 2")	8,220 (26' 12")
B' Max. digging depth (8' level)	5,950 (19' 6")	6,160 (20' 3")	6,470 (21' 3")	7,210 (23' 8")	8,080 (26' 6")
C Max. vertical wall digging depth	5,710 (18' 9")	5,980 (19' 7")	5,920 (19' 5")	6,360 (20' 10")	7,260 (23' 10")
D Max. digging height	9,940 (32' 7")	10,220 (33' 6")	10,170 (33' 4")	10,310 (33' 10")	10,710 (35' 2")
E Max. dumping height	6,780 (22' 3")	7,050 (23' 2")	7,050 (23' 2")	7,240 (23' 9")	7,630 (25' 0")
F Min. swing radius	4,520 (14' 10")	4,700 (15' 5")	4,550 (14' 11")	4,460 (14' 8")	4,470 (14' 8")

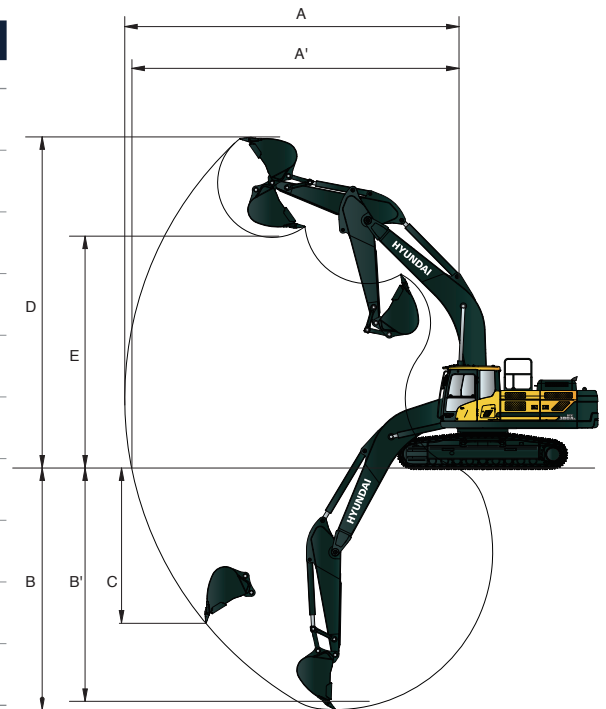

HX350L DIGGING FORCE

Boom	Length	mm (ft-in)	6,150 (20' 2")		6,450 (21' 2")] : Power Boost
	Weight	kg (lb)	2,950 (6,500)		3,030 (6,680)			
Arm	Length	mm (ft-in)	2,200 (7' 3")	2,200 (7' 3")	2,500 (8' 2")	3,200 (10' 6")	4,050 (13' 3")	
	Weight	kg (lb)	1,560 (3,440)	1,560 (3,440)	1,650 (3,640)	1,770 (3,900)	1,870 (4,120)	
Bucket digging force	SAE	kN	186.3 [203.3]	186.3 [203.3]	187.3 [204.4]	188.3 [205.5]	189.3 [206.4]	
		kgf	19,000 [20,730]	19,000 [20,730]	19,100 [20,840]	19,200 [20,950]	19,300 [21,050]	
		lbf	41,890 [45,700]	41,890 [45,700]	42,110 [45,940]	42,330 [46,190]	42,550 [46,410]	
	ISO	kN	214.8 [234.3]	214.8 [234.3]	215.7 [235.4]	216.7 [236.4]	217.7 [237.5]	
		kgf	21,900 [23,890]	21,900 [23,890]	22,000 [24,000]	22,100 [24,110]	22,200 [24,220]	
		lbf	48,280 [52,670]	48,280 [52,670]	48,500 [52,910]	48,720 [53,150]	48,940 [53,400]	
Arm crowd force	SAE	kN	195.2 [212.9]	195.2 [212.9]	175.5 [191.5]	140.2 [153.0]	118.7 [129.4]	
		kgf	19,900 [21,710]	19,900 [21,710]	17,900 [19,530]	14,300 [15,600]	12,100 [13,200]	
		lbf	43,870 [47,860]	43,870 [47,860]	39,460 [43,060]	31,530 [34,390]	26,680 [29,100]	
	ISO	kN	205.0 [223.6]	205.0 [223.6]	184.4 [201.1]	145.1 [158.4]	123.6 [134.8]	
		kgf	20,900 [22,800]	20,900 [22,800]	18,800 [20,510]	14,800 [16,150]	12,600 [13,750]	
		lbf	46,080 [50,270]	46,080 [50,270]	41,450 [45,220]	32,630 [35,600]	27,780 [30,310]	

SPECIFICATIONS HX350AL

Powered By Cummins Performance Series Engine

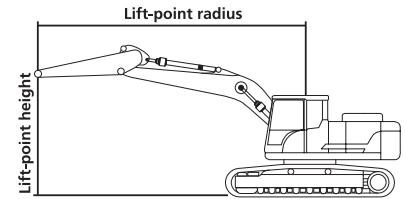

Lifting Capacity

Boom: 6.45 m (21' 2")

Arm: 3.2 m (10' 6")

Bucket: 1.44 m³ (1.88 yd³) SAE heaped

Shoe 800 mm (32") triple grouser, CWT 6,600 kg (14,550 lb)

Capacities based on North American Standard Configuration in accordance with ISO condition 2 standard.



Rating over front



Rating over side or 360 degree

Lift-point height m (ft)		Lift-point radius										At max. reach		
		3.0 m (9.8 ft)		4.5 m (14.8 ft)		6.0 m (19.7 ft)		7.5 m (24.6 ft)		9.0 m (29.5 ft)		Capacity		Reach
														m (ft)
7.5 m	kg							*6830	*6830			*5610	*5610	7.74
24.6 ft	lb							*15060	*15060			*12370	*12370	(25.4)
6.0 m	kg							*7900	7580			*5430	*5430	8.62
19.7 ft	lb							*17420	16710			*11970	*11970	(28.3)
4.5 m	kg		*12020	*12020	*9700	*9700	*8550	7370	*6670	5510	*5450	5340	9.17	
14.8 ft	lb		*26500	*26500	*21380	*21380	*18850	16250	*14700	12150	*12020	11770	(30.1)	
3.0 m	kg		*15600	14970	*11400	9830	*9430	7110	7970	5400	*5650	5000	9.44	
9.8 ft	lb		*34390	33000	*25130	21670	*20790	15670	17570	11900	*12460	11020	(31.0)	
1.5 m	kg		*17450	14110	*12910	9380	*10290	6860	7840	5280	*6050	4890	9.47	
4.9 ft	lb		*38470	31110	*28460	20680	*22690	15120	17280	11640	*13340	10780	(31.1)	
Ground Line	kg		*17260	13760	*13850	9090	10090	6680	7750	5190	*6720	5000	9.25	
	lb		*38050	30340	*30530	20040	22240	14730	17090	11440	*14820	11020	(30.4)	
-1.5 m	kg	*10800	*10800	*18990	13700	14000	8970	10000	6600		*7860	5360	8.77	
-4.9 ft	lb	*23810	*23810	*41870	30200	30860	19780	22050	14550		*17330	11820	(28.8)	
-3.0 m	kg	*17470	*17470	*17780	13820	*13420	9010	10050	6640		9230	6140	7.98	
-9.8 ft	lb	*38510	*38510	*39200	30470	*29590	19860	22160	14640		20350	13540	(26.2)	
-4.5 m	kg	*20720	*20720	*15280	14130	*11480	9230				*9660	7880	6.76	
-14.8 ft	lb	*45680	*45680	*33690	31150	*25310	20350				*21300	17370	(22.2)	

NOTES:

- Lifting capacities are based on ISO 10567.
- Lifting capacity of the HX Series does not exceed 75% of tipping load with the machine on firm, level ground or 87% of full hydraulic capacity.
- The Lift-point is bucket pivot mounting pin on the arm (without bucket mass).
- (*) indicates load limited by hydraulic capacity.



ENGINE	STD	OPT
Cummins L9 Engine	•	
HYDRAULIC SYSTEM	STD	OPT
INTELLIGENT POWER CONTROL (IPC)		
3-Power Mode, 2-Work Mode, User Mode	•	
Variable Power Control	•	
Pump Flow Control (Upgraded IPC)	•	
Attachment Mode Flow Control		•
Engine Auto Idle	•	
Engine Auto Shutdown Control	•	
Hyundai Bio Hydraulic Oil (HBHO)		•
CAB & INTERIOR	STD	OPT
ISO STANDARD CABIN		
Cabin Lights (LED)		•
LED Room Lamp	•	
Cabin Front Window Rain Guard		•
Cabin Roof-Steel Cover		•
Low Wiper		•
Rise-Up Type Windshield Wiper	•	
Radio / USB Player	•	
Handsfree Mobile Phone System with USB	•	
12 Volt Power Outlet (24V DC to 12V DC Converter)	•	
Electric Horn	•	
All-Weather Steel Cab with 360° Visibility	•	
Safety glass - Tempered glass	•	
Safety glass - Tempered glass with front laminated glass		•
Sliding Fold-In Front Window	•	
Sliding Side Window(LH)	•	
Hot & Cool Box	•	
Storage Compartment and Ashtray	•	
Transparent Cabin Roof-Cover	•	
Sun Visor	•	
Door and Cab Locks, One Key	•	
Smart Key & Start		•
Mechanical Suspension Seat With Heater	•	
Pilot-Operated Slidable Joystick	•	
Console Box Height Adjust System	•	
AUTOMATIC CLIMATE CONTROL		
Air Conditioner & Heater	•	
Defroster	•	
AUTOMATIC STARTING AID(AIR GRID HEATER) FOR WEATHER		
Starting Aid (Air grid heater) for Cold Weather	•	
CENTRALIZED MONITORING		
8" LCD Display	•	
Engine Speed or Trip Meter/Accel.	•	
Engine Coolant Temperature Gauge	•	
Max Power	•	
Low Speed/High Speed	•	
Auto Idle	•	
Overload warning with alarm		•
Check Engine	•	
Air Cleaner Clogging	•	
Indicators	•	
ECO Gauges	•	
Fuel Level Gauge	•	
Hyd. Oil Temperature Gauge	•	
Fuel Warmer	•	
Warnings	•	
Communication Error	•	
Low Battery	•	
Clock	•	
SEAT		
Adjustable Air Suspension Seat with Heater		•

CAB & INTERIOR	STD	OPT
CABIN FOPS/FOG (ISO 10262) LEVEL 2		
FOPS (Falling Object Protective Structure)-ISO 10262 Level 2		•
CAB & INTERIOR	STD	OPT
CABIN ROPS (ISO 12117-2)		
ROPS (Roll Over Protective Structure)	•	
SAFETY	STD	OPT
Battery Master Switch	•	
Rearview Camera		•
AAVM (Advanced Around View Monitoring)		•
Six Front Working Lights (4 Boom Mounted, 2 Front Frame Mounted)	•	
Travel Alarm	•	
Rear Work Lamp		•
Beacon Lamp		•
Automatic Swing Brake	•	
Boom Holding System	•	
Arm Holding System	•	
Safety Lock Valve for Boom Cylinder with Overload Warning Device		•
Safety Lock Valve for Arm Cylinder		•
Swing Lock System		•
Three Outside Rearview Mirror	•	
OTHERS	STD	OPT
Removable Clean-Out Dust Net for Cooler	•	
Removable Reservoir Tank	•	
Fuel Pre-Filter(1,000hr)	•	
Fuel Warmer	•	
Self-Diagnostics System	•	
Hi-Mate (Remote Management System)		•
Batteries (2 x 12V x 160 AH)	•	
Fuel Filler Pump (50 L/min)		•
Single-Acting Piping Kit (Breaker, etc.)		•
Double-Acting Piping Kit (Clamshell, etc.)		•
Rotating Piping Kit		•
Quick Coupler Piping		•
Quick Coupler		•
Boom Floating Control		•
One Pedal Straight Travel System		•
Accumulator for Lowering Work Equipment	•	
Pattern Change Valve (2 Patterns)		•
Tool Kit		•
BOOMS		
6.15m, 20' 2"		•
6.45m, 21' 2"	•	
ARMS		
2.2m, 7' 3"		•
2.5m, 8' 2"		•
3.2m, 10' 6"	•	
4.05m, 13' 3"		•
UNDERCARRIAGE	STD	OPT
Lower Frame Under Cover (Additional)		•
Lower Frame Under Cover (Normal)	•	
TRACK SHOES		
Triple Grousers Shoe (600mm, 24")	•	
Triple Grousers Shoe (700mm, 28")		•
Triple Grousers Shoe (800mm, 32")	•	
Triple Grousers Shoe (900mm, 36")		•
Double Grousers Shoe (700mm, 28")		•
Track Rail Guard	•	
Full Track Rail Guard		•



www.hceamericas.com
6100 Atlantic Blvd., Norcross, GA 30071
TEL (678) 823-7777 FAX (678) 823-7778

Printed in U.S.A.

PLEASE CONTACT

1097-EX-SP 9/2020v6