

WOODS BATWING[®] ROTARY CUTTER BW240HD, BW240HDQ

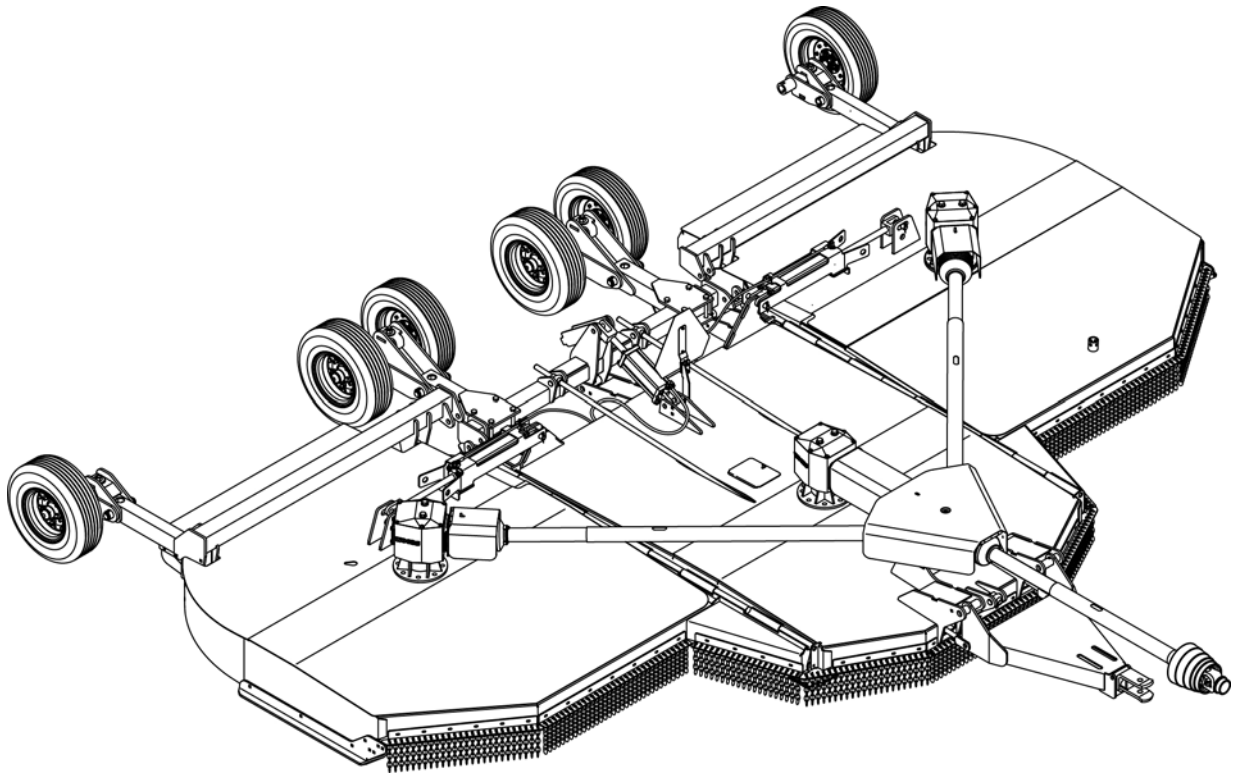

MAN0763

(Rev. 9/11/2013)

WOODS[®]
Woods Equipment Company

OPERATOR'S MANUAL

TO THE DEALER:

Assembly and proper installation of this product is the responsibility of the Woods® dealer. Read manual instructions and safety rules. Make sure all items on the Dealer's Pre-Delivery and Delivery Check Lists in the Operator's Manual are completed before releasing equipment to the owner.

The dealer must complete the online Product Registration form at the Woods Dealer Website which certifies that all Dealer Check List items have been completed. Dealers can register all Woods product at dealer.WoodsEquipment.com under Product Registration.

Failure to register the product does not diminish customer's warranty rights.

TO THE OWNER:

Read this manual before operating your Woods equipment. The information presented will prepare you to do a better and safer job. Keep this manual handy for ready reference. Require all operators to read this manual carefully and become acquainted with all adjustment and operating procedures before attempting to operate. Replacement manuals can be obtained from your dealer. To locate your nearest dealer, check the Dealer Locator at www.WoodsEquipment.com, or in the United States and Canada call 1-800-319-6637.

The equipment you have purchased has been carefully engineered and manufactured to provide dependable and satisfactory use. Like all mechanical products, it will require cleaning and upkeep. Lubricate the unit as specified. Observe all safety information in this manual and safety decals on the equipment.

For service, your authorized Woods dealer has trained mechanics, genuine Woods service parts, and the necessary tools and equipment to handle all your needs.

Use only genuine Woods service parts. Substitute parts will void the warranty and may not meet standards required for safe and satisfactory operation. Record the model number and serial number of your equipment in the spaces provided:

Model: _____ **Date of Purchase:** _____

Serial Number: (see Safety Decal section for location) _____

Provide this information to your dealer to obtain correct repair parts.

Throughout this manual, the term **NOTICE** is used to indicate that failure to observe can cause damage to equipment. The terms **CAUTION**, **WARNING**, and **DANGER** are used in conjunction with the Safety-Alert Symbol (a triangle with an exclamation mark) to indicate the degree of hazard for items of personal safety.



This is the safety alert symbol. It is used to alert you to potential physical injury hazards. Obey all safety messages that follow this symbol to avoid possible injury or death.



Indicates a hazardous situation that, if not avoided, will result in death or serious injury.



Indicates a hazardous situation that, if not avoided, could result in death or serious injury.



Indicates a hazardous situation that, if not avoided, could result in minor or moderate injury.

**IMPORTANT
or NOTICE**

Is used to address practices not related to physical injury.

NOTE

Indicates helpful information.

WOODS
Woods Equipment Company

ALITEC™
BMP®
CENTRAL FABRICATORS®
GANNON®
GILL®
WAIN-ROY®
WOODS®

2 Introduction

Gen'1 (Rev. 3/28/2012)

TABLE OF CONTENTS

INTRODUCTION	2
SPECIFICATIONS	4
GENERAL INFORMATION	4
SAFETY VIDEO ORDER FORM	5
SAFETY RULES	7
SAFETY DECALS	11
OPERATION	14
OWNER SERVICE	20
TROUBLE SHOOTING	25
DEALER SERVICE	26
ASSEMBLY INSTRUCTIONS	34
DEALER CHECK LIST	47
INDEX TO PARTS LISTS	49
BOLT TORQUE CHART	77
BOLT SIZE CHART & ABBREVIATIONS	78
INDEX	79
PRODUCT WARRANTY	80
REPLACEMENT PARTS WARRANTY	INSIDE BACK COVER

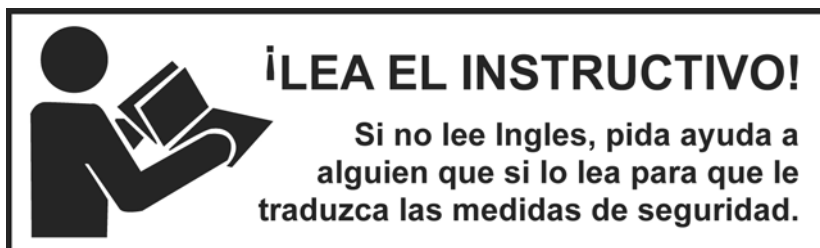

NOTICE:

If you would like to receive a free Spanish language translation of the Safety Rules section of this manual, plus a set of Spanish language safety decals, please contact your local Woods dealer.

AVISO:

Si desea recibir una traducción al español gratuita de la sección Reglas de seguridad de este manual y un juego de etiquetas de seguridad en español, por favor comuníquese con su concesionario local de Woods.



**Ce manuel fait partie de la machine. Conserver le
manuel avec la machine lorsqu'elle est vendue.**

SPECIFICATIONS

BW240HD / BW240HDQ

Cutting Height (Varies with tire selection)	2" - 15"
Cutting Width	240" (20')
Overall Width249"
Transport Width123"
Tractor HP70 - 300
Blade Spindle	3
Blade Overlap6"
Number of Blades	6
Blade Rotation	Left Spindle: CW; Right Spindle & Center: CCW
Input Driveline	Cat 5 Heavy
CV	Cat 6
Side Frame Thickness	1/4"
Weight (approximate lbs. with 8 large aircraft tires, single chain shielding & CV drive).	6435
Wheel Size	15" Rims; 24" Aircraft, 29" Aircraft, 21" Solid
Torsion Protection	Slip Clutch

	BW240HD	BW240HDQ
Tractor PTO rpm	540	1000
Blade Speed (Feet per minute)	15,450	16,300

GENERAL INFORMATION

WARNING

■ Some illustrations in this manual show the equipment with safety shields removed to provide a better view. This equipment should never be operated with any necessary safety shielding removed.

The purpose of this manual is to assist you in operating and maintaining your cutter. Read it carefully. It furnishes information and instructions that will help you achieve years of dependable performance. These instructions have been compiled from extensive field experience and engineering data. Some information may be general in nature due to unknown and varying

operating conditions. However, through experience and these instructions, you should be able to develop procedures suitable to your particular situation.

The illustrations and data used in this manual were current at the time of printing but, due to possible inline production changes, your machine may vary slightly in detail. We reserve the right to redesign and change the machines as may be necessary without notification.

Throughout this manual, references are made to right and left directions. These are determined by standing behind the equipment facing the direction of forward travel. Blade rotation is clockwise (left wing) and counterclockwise (right wing and center section) as viewed from the top of the cutter.

BE SAFE!

BE ALERT!

BE ALIVE!

BE TRAINED

Before Operating Mowers!



ASSOCIATION OF
EQUIPMENT
MANUFACTURERS

*Safety Training
Does Make a Difference.*

Free Mower Safety Video

Fill out and return the order form and we will send you a FREE VHS or DVD video outlining ***Industrial and Agricultural Mower Safety Practices***. The 22 minute video, developed in cooperation with AEM (Association of Equipment Manufacturers), reinforces the proper procedures to follow while operating your mowing equipment. The video does not replace the information contained in the Operator's Manual, so please review this manual thoroughly before operating your new mowing equipment.

Also, available from the Association of Equipment Manufacturers:

A large variety of training materials (ideal for groups) are available for a nominal charge from AEM. Following is a partial list:

- **Training Package for Rotary Mowers/Cutters-English**
Contains: DVD & VHS (English)
 Guidebook for Rotary Mowers/Cutters (English)
 AEM Industrial/Agricultural Mower Safety Manual (English)
 AEM Agricultural Tractor Safety Manual (English)

- **Training Package for Rotary Mowers/Cutters-English/Spanish**
Contains: DVD & VHS (English/Spanish)
 Guidebook for Rotary Mowers/Cutters (English/Spanish)
 AEM Industrial/Agricultural Mower Safety Manual (English/Spanish)
 AEM Agricultural Tractor Safety Manual (English/Spanish)

AEM training packages are available through:

AEM at: www.aem.org

or

Universal Lithographers, Inc.

Email: aem@ulilitho.com

800-369-2310 tel

866-541-1668 fax



Free Mower/Cutter Safety Video Order Form

✓ (Select one)

Please send me

VHS Format - VHS01052 Safety Video

DVD Format - DVD01052 Safety Video

Name: _____ Phone: _____

Address: _____

Mower/Cutter Model: _____ Serial #: _____

Send to: ATTENTION: DEALER SERVICES
 WOODS EQUIPMENT COMPANY
 PO BOX 1000
 OREGON IL 61061-1000
 USA

SAFETY RULES



ATTENTION! BECOME ALERT! YOUR SAFETY IS INVOLVED!



Safety is a primary concern in the design and manufacture of our products. Unfortunately, our efforts to provide safe equipment can be wiped out by an operator's single careless act.

In addition to the design and configuration of equipment, hazard control and accident prevention are dependent upon the awareness, concern, judgement, and proper training of personnel involved in the operation, transport, maintenance, and storage of equipment.

It has been said, "The best safety device is an informed, careful operator." We ask you to be that kind of operator.

INSTALLATION

■ **Hydraulics must be connected as instructed in this manual. Do not substitute parts, modify, or connect in any other way.**

TRAINING

■ **Safety instructions are important! Read all attachment and power unit manuals; follow all safety rules and safety decal information. (Replacement manuals and safety decals are available from your dealer. To locate your nearest dealer, check the Dealer Locator at www.WoodsEquipment.com, or in the United States and Canada call 1-800-319-6637.) Failure to follow instructions or safety rules can result in serious injury or death.**

■ **If you do not understand any part of this manual and need assistance, see your dealer.**

■ **Know your controls and how to stop engine and attachment quickly in an emergency.**

■ **Operators must be instructed in and be capable of the safe operation of the equipment, its attachments, and all controls. Do not allow anyone to operate this equipment without proper instructions.**

■ **Keep hands and body away from pressurized lines. Use paper or cardboard, not hands or other body parts to check for leaks. Wear safety goggles. Hydraulic fluid under pressure can easily penetrate skin and will cause serious injury or death.**

■ **Make sure that all operating and service personnel know that if hydraulic fluid penetrates skin, it must be surgically removed as soon as possible by a doctor familiar with this form of injury or gangrene, serious injury, or death will result. CON-**

TACT A PHYSICIAN IMMEDIATELY IF FLUID ENTERS SKIN OR EYES. DO NOT DELAY.

■ **Never allow children or untrained persons to operate equipment.**

PREPARATION

■ **Check that all hardware is properly installed. Always tighten to torque chart specifications unless instructed otherwise in this manual.**

■ **Air in hydraulic systems can cause erratic operation and allows loads or equipment components to drop unexpectedly. When connecting equipment or hoses or performing any hydraulic maintenance, purge any air in hydraulic system by operating all hydraulic functions several times. Do this before putting into service or allowing anyone to approach the equipment.**

■ **Make sure all hydraulic hoses, fittings, and valves are in good condition and not leaking before starting power unit or using equipment. Check and route hoses carefully to prevent damage. Hoses must not be twisted, bent sharply, kinked, frayed, pinched, or come into contact with any moving parts. Operate moveable components through full operational range to check clearances. Replace any damaged hoses immediately.**

■ **After connecting hoses, check that all control lever positions function as instructed in the Operator's Manual. Do not put into service until control lever and equipment movements are correct.**

■ **Set tractor hydraulic relief valve at 2500 psi (170 bars) (17,000 kPa) to prevent injury and equipment damage due to hydraulic system failure.**

■ **Your dealer can supply original equipment hydraulic accessories and repair parts. Substitute parts may not meet original equipment specifications and may be dangerous.**

■ **Always wear relatively tight and belted clothing to avoid getting caught in moving parts. Wear sturdy, rough-soled work shoes and protective equipment for eyes, hair, hands, hearing, and head; and respirator or filter mask where appropriate.**

■ **Make sure attachment is properly secured, adjusted, and in good operating condition.**

■ **Make sure spring-activated locking pin or collar slides freely and is seated firmly in tractor PTO spline groove.**

(Safety Rules continued on next page)



SAFETY RULES

ATTENTION! BECOME ALERT! YOUR SAFETY IS INVOLVED!



(Safety Rules continued from previous page)

- Make sure driveline guard tether chains are attached to the tractor and equipment as shown in the pamphlet that accompanies the driveline. Replace if damaged or broken. Check that driveline guards rotate freely on driveline before putting equipment into service.
- Connect PTO driveline directly to power unit PTO shaft. Never use adapter sleeves or adapter shafts. Adapters can cause driveline failures due to incorrect spline or incorrect operating length and can result in personal injury or death.
- Before starting power unit, check all equipment driveline guards for damage. Replace any damaged guards. Make sure all guards rotate freely on all drivelines. If guards do not rotate freely on drivelines, repair and replace bearings before putting equipment into service.
- Power unit must be equipped with ROPS or ROPS cab and seat belt. Keep seat belt securely fastened. Falling off power unit can result in death from being run over or crushed. Keep foldable ROPS system in “locked up” position at all times.
- Remove accumulated debris from this equipment, power unit, and engine to avoid fire hazard.
- Make sure all safety decals are installed. Replace if damaged. (See Safety Decals section for location.)
- Make sure shields and guards are properly installed and in good condition. Replace if damaged.
- Do not put this equipment into service unless all side skids are properly installed and in good condition. Replace if damaged.
- A minimum 20% of tractor and equipment weight must be on the tractor front wheels when attachments are in transport position. Without this weight, front tractor wheels could raise up resulting in loss of steering. The weight may be attained with front wheel weights, ballast in tires or front tractor weights. Weigh the tractor and equipment. Do not estimate.
- The offset model is unstable without adequate counterweight. Use counterweight box loaded with 1190 lbs (539.8 kg) of steel.

TRANSPORTATION

- Power unit must be equipped with ROPS or ROPS cab and seat belt. Keep seat belt securely fastened. Falling off power unit can result in death from being run over or crushed. Keep foldable ROPS system in “locked up” position at all times.
- Always raise unit and install transport locks before transporting. Leak down or failure of mechanical or hydraulic system can cause equipment to drop.
- Always attach safety chain to tractor drawbar when transporting unit.
- Always comply with all state and local lighting and marking requirements.
- Never allow riders on power unit or attachment.
- Do not operate PTO during transport.
- Do not operate or transport on steep slopes.
- Do not operate or transport equipment while under the influence of alcohol or drugs.
- The maximum transport speed for towed and semi-mounted machines is 20 mph (32 km/h). Regardless of the maximum speed capability of the towing tractor, do not exceed the implement’s maximum transport speed. Doing so could result in:
 - Loss of control of the implement and tractor
 - Reduced or no ability to stop during braking
 - Implement tire failure
 - Damage to the implement or its components.
- Use additional caution and reduce speed when under adverse surface conditions, turning, or on inclines.
- Never tow this implement with a motor vehicle.

OPERATION

- Do not allow bystanders in the area when operating, attaching, removing, assembling, or servicing equipment.
- Never walk, stand, or place yourself or others under a raised wing or in the path of a lowering wing. Hydraulic system leak-down, hydraulic system failures, mechanical failures, or movement of control levers can cause wings to drop unexpectedly and cause severe injury or death.

(Safety Rules continued on next page)



SAFETY RULES

ATTENTION! BECOME ALERT! YOUR SAFETY IS INVOLVED!



(Safety Rules continued from previous page)

■ Full chain or rubber shielding must be installed when operating in populated areas or other areas where thrown objects could injure people or damage property.

- If this machine is not equipped with full chain or rubber shielding, operation must be stopped when anyone comes within 300 feet (92 m).
- This shielding is designed to reduce the risk of thrown objects. The mower deck and protective devices cannot prevent all objects from escaping the blade enclosure in every mowing condition. It is possible for objects to ricochet and escape, traveling as much as 300 feet (92 m).

■ Never direct discharge toward people, animals, or property.

■ Do not operate or transport equipment while under the influence of alcohol or drugs.

■ Operate only in daylight or good artificial light.

■ Keep hands, feet, hair, and clothing away from equipment while engine is running. Stay clear of all moving parts.

■ Always comply with all state and local lighting and marking requirements.

■ Never allow riders on power unit or attachment.

■ Power unit must be equipped with ROPS or ROPS cab and seat belt. Keep seat belt securely fastened. Falling off power unit can result in death from being run over or crushed. Keep foldable ROPS system in “locked up” position at all times.

■ Always sit in power unit seat when operating controls or starting engine. Securely fasten seat belt, place transmission in neutral, engage brake, and ensure all other controls are disengaged before starting power unit engine.

■ Operate tractor PTO at 540 RPM (1000 RPM on Q Series cutters). Do not exceed.

■ Raise or lower wings slowly to prevent personal injury or damage to cutter.

■ Look down and to the rear and make sure area is clear before operating in reverse.

■ Do not operate or transport on steep slopes.

■ Do not stop, start, or change directions suddenly on slopes.

■ Watch for hidden hazards on the terrain during operation.

■ Stop power unit and equipment immediately upon striking an obstruction. Turn off engine, remove key, inspect, and repair any damage before resuming operation.

■ Continuous operation while the clutch is slipping could cause heat build-up resulting in fire. Adjust slip clutch pressure by tightening springs to the dimension shown in the “Owner Service” section. If clutch is set to minimum spring length, replace the friction disks as shown.

■ On pull-type or semi-mounted units with optional hydraulic cutting height adjustment, use a single-acting cylinder with a maximum extended length of 28-1/4" (718 mm) from attaching point center to center.

MAINTENANCE

■ Before servicing, adjusting, repairing or unplugging, stop tractor engine, place all controls in neutral, set park brake, remove ignition key, and wait for all moving parts to stop.

■ Before dismounting power unit or performing any service or maintenance, follow these steps: disengage power to equipment, lower the 3-point hitch and all raised components to the ground, operate valve levers to release any hydraulic pressure, set parking brake, stop engine, remove key, and unfasten seat belt.

■ Do not modify or alter or permit anyone else to modify or alter the equipment or any of its components in any way.

■ Your dealer can supply original equipment hydraulic accessories and repair parts. Substitute parts may not meet original equipment specifications and may be dangerous.

■ To prevent contamination during maintenance and storage, clean and then cover hose ends, fittings, and hydraulic ports with tape.

■ Do not allow bystanders in the area when operating, attaching, removing, assembling, or servicing equipment.

(Safety Rules continued on next page)



SAFETY RULES

ATTENTION! BECOME ALERT! YOUR SAFETY IS INVOLVED!



(Safety Rules continued from previous page)

- Never go underneath equipment (lowered to the ground or raised) unless it is properly blocked and secured. Never place any part of the body underneath equipment or between moveable parts even when the engine has been turned off. Hydraulic system leak down, hydraulic system failures, mechanical failures, or movement of control levers can cause equipment to drop or rotate unexpectedly and cause severe injury or death. Follow Operator's Manual instructions for working underneath and blocking requirements or have work done by a qualified dealer.
- Keep all persons away from operator control area while performing adjustments, service, or maintenance.
- Make certain all movement of equipment components has stopped before approaching for service.
- Frequently check blades. They should be sharp, free of nicks and cracks, and securely fastened.
- Do not handle blades with bare hands. Careless or improper handling may result in serious injury.
- Your dealer can supply genuine replacement blades. Substitute blades may not meet original equipment specifications and may be dangerous.
- Tighten all bolts, nuts, and screws to torque chart specifications. Check that all cotter pins are installed securely to ensure equipment is in a safe condition before putting unit into service.
- Make sure all safety decals are installed. Replace if damaged. (See Safety Decals section for location.)
- Make sure shields and guards are properly installed and in good condition. Replace if damaged.

- Never perform service or maintenance with engine running.
- Do not disconnect hydraulic lines until machine is securely blocked or placed in lowest position and system pressure is released by operating valve levers.
- Service and maintenance work not covered in OWNER SERVICE must be done by a qualified dealership. Special skills, tools, and safety procedures may be required. Failure to follow these instructions can result in serious injury or death.
- Explosive separation of tire and rim parts can cause serious injury or death. Release all air pressure before loosening bolts on wheel.

STORAGE

- Before disconnecting and storing, follow these instructions:
 - Store on level, solid ground.
 - Disconnect driveline and secure up off the ground.
 - Lower wings to ground.
 - Raise cutter center section and pin transport bar in raised position.
 - Attach parking jack and raise tongue weight off tractor drawbar.
 - Place wedge blocks at front and rear of wheels on center section and each wing to prevent wheel rotation.
 - Securely block all four corners of center section and each wing with jackstands.
 - Remove hydraulic hoses after tractor is turned off and all system pressure is released by operating valve levers several times.
 - Remove safety tow chain.
 - Remove retainer pin and high strength drawbar pin.
- Keep children and bystanders away from storage area.





SAFETY & INSTRUCTIONAL DECALS

ATTENTION! BECOME ALERT! YOUR SAFETY IS INVOLVED!
Replace Immediately If Damaged!



Model#
Serial#
(BAR CODE)
WOODS Woods Equipment Company Oregon, Illinois 61061 USA

1 - SERIAL NUMBER PLATE

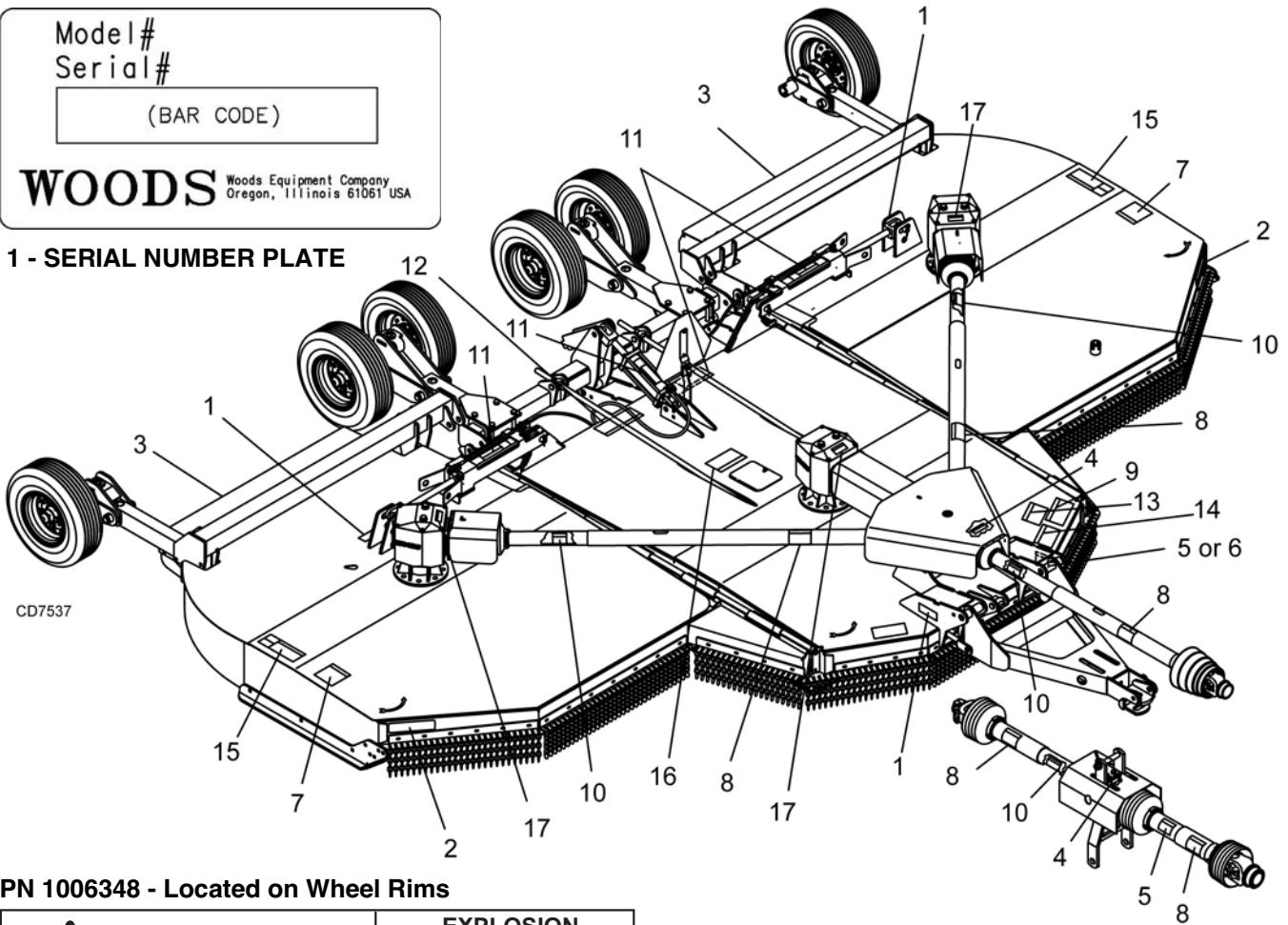

PN 1006348 - Located on Wheel Rims

WARNING	EXPLOSION HAZARD
<small>RELEASE ALL AIR PRESSURE BEFORE LOOSENING BOLTS. FAILURE TO DO SO COULD RESULT IN SERIOUS INJURY OR DEATH. MAX. SPEED: 20 MPH, MAX. WEIGHT: 4000 LBS., MAX. AIR PRESSURE: 40 PSI.</small>	

BE CAREFUL!

Use a clean, damp cloth to clean safety decals.

Avoid spraying too close to decals when using a pressure washer; high-pressure water can enter through very small scratches or under edges of decals causing them to peel or come off.

Replacement safety decals can be ordered free from your Woods dealer. To locate your nearest dealer, check the Dealer Locator at www.WoodsEquipment.com, or in the United States and Canada call 1-800-319-6637.

2 - FRONT AMBER REFLECTOR (PN 1002940)

3 - REAR RED REFLECTOR (PN 57123)

4 - PN 18869

DANGER
SHIELD MISSING
DO NOT OPERATE - PUT SHIELD ON

17 - PN 1004114

DANGER
If shaft connection is visible, shield is missing. Replace shield before operating equipment.

SAFETY & INSTRUCTIONAL DECALS



ATTENTION! BECOME ALERT! YOUR SAFETY IS INVOLVED!



Replace Immediately If Damaged!

! WARNING

**DO NOT EXCEED PTO SPEED OF
1000 RPM**

PTO speeds higher than 1000 RPM can cause equipment failure and personal injury.

15922-C

5 - PN 15922

! WARNING

**DO NOT EXCEED PTO SPEED OF
540 RPM**

PTO speeds higher than 540 RPM can cause equipment failure and personal injury.

18866-D

OR

6 - PN 18866

7 - PN 15503

! DANGER



**ROTATING BLADES AND
THROWN OBJECTS**

- Do not put hands or feet under or into mower when engine is running.
- Before mowing, clear area of objects that may be thrown by blade.
- Keep bystanders away.
- Keep guards in place and in good condition.

**BLADE CONTACT OR THROWN OBJECTS CAN
CAUSE SERIOUS INJURY OR DEATH.**

15503-C

8 - PN 18864

! DANGER



**ROTATING DRIVELINE
CONTACT CAN CAUSE DEATH
KEEP AWAY!**

DO NOT OPERATE WITHOUT -

- All driveline guards, tractor and equipment shields in place
- Drivelines securely attached at both ends
- Driveline guards that turn freely on driveline

18864-C

9 - PN 18865

! WARNING



FALLING OFF CAN RESULT IN BEING RUN OVER.

- Tractor must be equipped with ROPS (or ROPS CAB) and seat belt. Keep foldable ROPS systems in "locked up" position at all times.
- Buckle Up! Keep seat belt securely fastened.
- Allow no riders.

RAISED EQUIPMENT CAN DROP AND CRUSH.

- Before working underneath, follow all instructions and safety rules in operator's manual and securely block up all corners of equipment with jack stands.
- Securely blocking prevents equipment dropping from hydraulic leak-down, hydraulic system failures or mechanical component failures.

**FALLING OFF OR FAILING TO BLOCK SECURELY CAN
RESULT IN SERIOUS INJURY OR DEATH.**

18865-C

11 - PN 19924

! WARNING



**HIGH-PRESSURE HYDRAULIC OIL LEAKS CAN PENETRATE SKIN
RESULTING IN SERIOUS INJURY, GANGRENE OR DEATH.**

- Check for leaks with cardboard; never use hand.
- Before loosening fittings: lower load, release pressure, and be sure oil is cool.
- Consult physician immediately if skin penetration occurs.



19924-B

SAFETY & INSTRUCTIONAL DECALS

ATTENTION! BECOME ALERT! YOUR SAFETY IS INVOLVED!

Replace Immediately If Damaged!

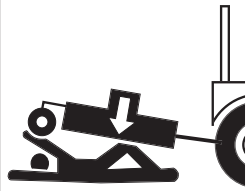
12 - PN 1004991

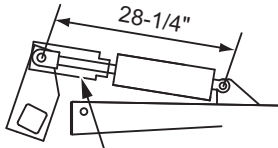
 <p>1004991</p>	 WARNING	TRANSPORT LOCK AND CYLINDER REQUIREMENTS SINGLE-ACTING FULL EXTENSION  <p>TRANSPORT LOCK</p>
	<p align="center">RAISED CUTTER CAN DROP AND CRUSH</p> <ul style="list-style-type: none"> ■ Cutters must be equipped with transport lock. ■ Before working underneath, transport lock must be in the raised position. All corners of cutter must be securely blocked with jack stands. ■ All transport components must be functional, kept in good condition, and stored on equipment. ■ Blocking up prevents cutter dropping from hydraulic leak down, hydraulic system failures, or mechanical component failures. <p align="center">FAILURE TO FOLLOW INSTRUCTIONS CAN RESULT IN SERIOUS INJURY OR DEATH.</p>	

10 - PN 33347

DANGER



GUARD MISSING. DO NOT OPERATE.

DANGER



GUARD MISSING. DO NOT OPERATE.

33347E

DANGER

13 - PN 1003751

WARNING



CRUSHING AND PINCHING HAZARD

- Be extremely careful handling various parts of the machine. They are heavy and hands, fingers, feet, and other body parts could be crushed or pinched between tractor and implement.
- Operate tractor controls from tractor seat only.
- Do not stand between tractor and implement when tractor is in gear.
- Make sure parking brake is engaged before going between tractor and implement.
- Stand clear of machine while in operation or when it is being raised or lowered.

FAILURE TO FOLLOW THESE INSTRUCTIONS COULD RESULT IN SERIOUS INJURY OR DEATH.

1003751-A

14 - PN 18877

WARNING

TO AVOID SERIOUS INJURY OR DEATH:

- Read Operator's Manual (available from dealer) and follow all safety precautions.
- Keep all shields in place and in good condition.
- Operate mower from tractor seat only.
- Lower mower, stop engine and remove key before dismounting tractor.
- Allow no children or untrained persons to operate equipment.
- Do not transport towed or semi-mounted units over 20 mph.

FAILURE TO OPERATE SAFELY CAN RESULT IN INJURY OR DEATH.

18877-C

15 - PN 18964

WARNING

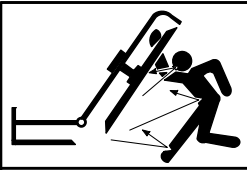

RAISED WING EXPOSES BLADE AND INCREASES THROWN OBJECT HAZARDS.

- Only raise for transport. Stop cutter and lock wing(s) up.



RAISED WING CAN FALL AND CRUSH.

- Keep away.
- Lock up with wing transport bars.
- Lower wing(s) after transport and for storage.

FAILURE TO FOLLOW INSTRUCTIONS CAN RESULT IN SERIOUS INJURY OR DEATH.

18964-A

16 - PN 15502

WARNING

ROTATING COMPONENTS

Do not operate without cover in place. Look and listen for rotation. Do not open cover until all components have stopped.

CONTACT WITH ROTATING PARTS CAN CAUSE SERIOUS INJURY.

15502-B

OPERATION

The designed and tested safety of this machine depends on it being operated within the limitations as explained in this manual. Be familiar with and follow all safety rules in the manual, on the cutter and on the tractor.

The safe operation of this cutter is the responsibility of the operator, who must be properly trained. The operator should be familiar with the equipment and all safety practices before starting operation. Read the safety information on page 7 through page 13.

Recommended tractor ground speed for most conditions is from 1 to 6 mph.

Always operate tractor PTO at 540 rpm on BW240HD and 1,000 rpm for the BW240HDQ.

⚠ DANGER

■ Full chain or rubber shielding must be installed when operating in populated areas or other areas where thrown objects could injure people or damage property.

- If this machine is not equipped with full chain or rubber shielding, operation must be stopped when anyone comes within 300 feet (92 m).
- This shielding is designed to reduce the risk of thrown objects. The mower deck and protective devices cannot prevent all objects from escaping the blade enclosure in every mowing condition. It is possible for objects to ricochet and escape, traveling as much as 300 feet (92 m).

⚠ WARNING

■ Never allow children or untrained persons to operate equipment.

■ Do not allow bystanders in the area when operating, attaching, removing, assembling, or servicing equipment.

■ Make sure spring-activated locking pin or collar slides freely and is seated firmly in tractor PTO spline groove.

⚠ CAUTION

■ Stop power unit and equipment immediately upon striking an obstruction. Turn off engine, remove key, inspect, and repair any damage before resuming operation.

■ Always wear relatively tight and belted clothing to avoid getting caught in moving parts. Wear sturdy, rough-soled work shoes and protective

equipment for eyes, hair, hands, hearing, and head; and respirator or filter mask where appropriate.

CONNECTING CUTTER TO TRACTOR

NOTICE

■ For tractors with a 1-3/8" diameter PTO shaft, the horizontal distance from the end of the tractor PTO shaft to the center of drawbar pin should be 14" for the 540 rpm cutter and 16" for the 1000 rpm cutter. Tractors with 1-3/4 20-spline PTO shaft should be set to 20". This will minimize joint knock and damage to drive components.

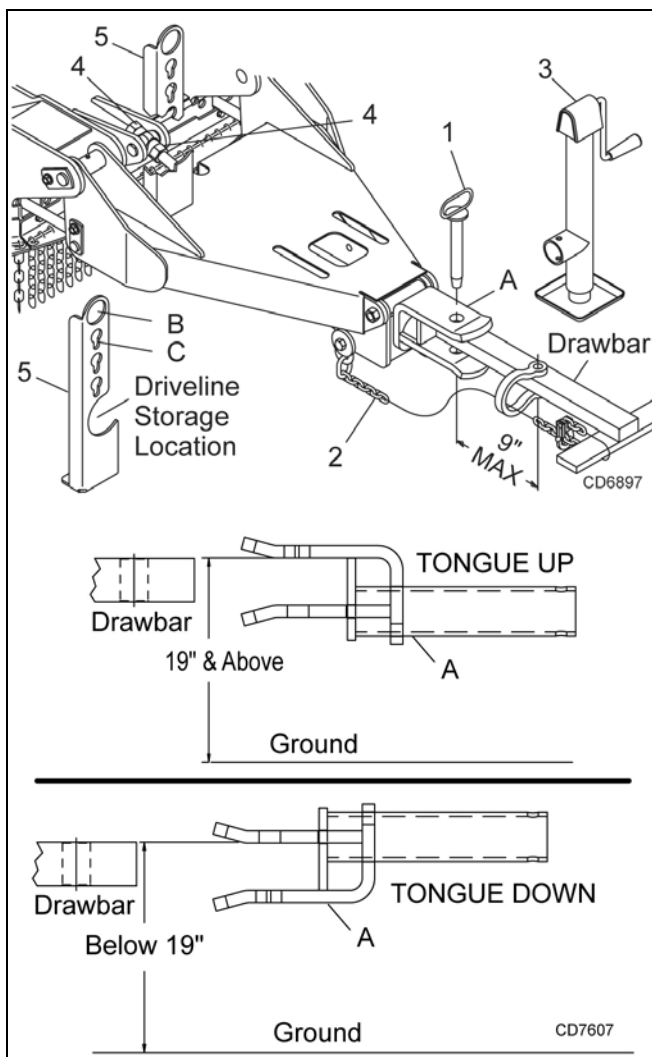

Figure 1. Cutter to Tractor Connection

1. Check tongue clevis to make sure it is adjusted to match your tractor PTO speed.
2. Position tongue clevis (A) up or down based on tractor drawbar height.
3. Attach cutter using a 1-1/8" clevis pin (1) and clip.

4. Attach safety tow chain (2) to drawbar support. Leave enough slack for turning.
5. Connect cutter driveline to tractor PTO shaft, making sure the spring-activated lock pin slides freely and is seated in tractor PTO splined groove.
6. Attach driveline shield tether chain to tractor drawbar to prevent rotation.

NOTE: CV driveline does not require a tether chain.

7. Remove parking jack (3) from the tongue and attach it to the storage post on the front of the left wing.

NOTE: Equal Angle Drive Only: With cutting height established, adjust the 3-joint H-frame bearing height so that the front driveline is parallel to the ground.

8. Adjust nuts (4) so tongue clevis (A) is parallel with the tractor drawbar.
9. Place driveline in storage position on the hose holder (5) when not in use.

Hydraulic Connection

1. Inspect hydraulic hoses to ensure they are in good condition.
2. Clean the fittings before connecting them to the tractor hydraulic ports.
3. Route the hose through the hose holder at the hitch and be sure the hose can slide freely in the holder. Do not allow hose slack to drag on the ground or become caught on tractor protrusions.
4. Attach the hydraulic hose to the tractor.
5. From the operator position, start tractor and raise and lower deck several times to purge trapped air from the hydraulic cylinder.

Interference Check

1. Be sure that tractor 3-point lift links do not interfere with hydraulic hoses, cutter driveline, or cutter frame.
2. Check for straight-ahead operation and at full turning angles. If there is any interference, remove the lower lift links.
3. Contact between tractor lift links and cutter parts can cause damage, especially when turning.

CV Driveline Turning Limits

NOTICE

- You must not exceed a turning angle of 80 degrees at the head of the Constant Velocity driveline or damage will occur.

1. To check for potential excessive turn angle, disconnect the driveline from tractor.
2. Start engine and turn as far right or left as possible.
3. Shut engine off and try to connect CV driveline to tractor. If it cannot be connected, the turn angle is too severe.
4. Restart engine and straighten angle slightly, shut off engine and try to connect CV driveline to tractor.
5. Repeat the process until the driveline can be connected. The point at which the driveline can be connected is the maximum turn that should be made.

Cutting Height Adjustment

NOTICE

- Avoid ground contact with blades. Striking ground with blades produces one of the most damaging shock loads a cutter can encounter. If this occurs repeatedly, the cutter, driveline, and gearboxes will be damaged.

 **WARNING**

- On pull-type or semi-mounted units with optional hydraulic cutting height adjustment, use a single-acting cylinder with a maximum extended length of 28-1/4" (718 mm) from attaching point center to center.

Cutting height range is from 2" to 15". A hydraulic cylinder or ratchet jack is available for cutting height adjustment.

When selecting a cutting height, you should consider the area of operation. If the ground is rolling and has mounds the blades could contact, set the cutting height accordingly. The cutting height (blade edge) is approximately 1" above the bottom of the side skid.

Cutting Height (Normal Mowing) - Center Section

1. Position the cutter on a hard level surface and select an approximate cutting height, Example 6".
2. Raise wings and lock them in the UP position.
3. Use the hydraulic cylinder or ratchet jack to raise or lower the center section to obtain a distance of 5" from bottom edge of skid shoe to the ground.
4. Place jackstands under the four corners of the center section. See illustration on page 21. Lower center section to relieve pressure on attitude rod nuts.
5. Loosen outer jam nut on the attitude rods.
6. Adjust inner nuts in or out until the rear of the cutter is approximately 1/2" higher than the front. See

Figure 1A. It's used as a starting point for adjusting the attitude rod, based on different tongue height and wheel options.

7. Raise cutter, remove jackstands and check deck height. Tighten jam nuts against sleeve.

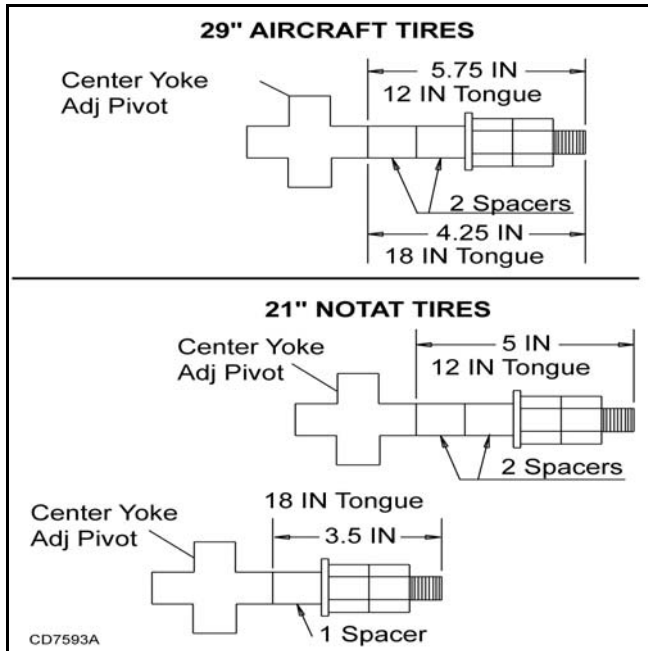

Figure 1A. Attitude Rod Adjustment

Cutting Height (Normal Mowing) - Wings

1. Lower wings to normal mowing position.
2. Loosen the jam nut on the adjustable link (turn buckle).
3. Lengthening the link will raise the wing, shortening the link will lower the wing. The rear edge of the wing should be parallel to the ground.
4. Make sure jam nuts are tightened once wing is leveled.

When using the cutter to shred, the rear of the cutter deck should be approximately 1/2" to 1" lower than the front.

NOTE: Equal Angle Drive Only: With the cutting height established, adjust the driveline carrier bearing in the H-frame to ensure the front driveline is parallel to the ground with cutter in cutting position.

TRACTOR OPERATION

WARNING

■ Power unit must be equipped with ROPS or ROPS cab and seat belt. Keep seat belt securely fastened. Falling off power unit can result in death

from being run over or crushed. Keep foldable ROPS system in "locked up" position at all times.

Use care when operating around tree limbs and other low objects. Avoid being knocked off tractor and being injured.

The cutter is operated with tractor controls. Engage the PTO at a low rpm to prevent excessive loads on the cutter drive system. Increase throttle to recommended PTO operating RPM.

Be sure operator is familiar with all controls and can stop tractor and cutter quickly in an emergency. The operator should give complete, undivided attention to operating tractor and cutter.

CUTTER OPERATION

When beginning operation of the cutter, make sure that all persons are in a safe location.

Power for operating the cutter is supplied by the tractor PTO. Operate PTO at 540 (1000 RPM for "Q" models).

Know how to stop the tractor and cutter quickly in an emergency.

Engage PTO at a low engine rpm to minimize stress on the drive system and gearbox.

With PTO engaged, raise PTO speed to 540 or 1000 RPM depending on model and maintain throughout cutting operation.

Gearbox protection is provided by a slip clutch with replacement fiber disc. The slip clutch is designed to slip when excessive torsional loads occur.

Move slowly into material. Adjust tractor ground speed to provide a clean cut without lugging the tractor engine.

Use a slow ground speed for better shredding.

Proper ground speed will depend on the terrain and the material's height, type, and density.

Normally, ground speed will range from 2 to 5 mph. Tall, dense material should be cut at a low speed; thin, medium-height material can be cut at a faster ground speed.

Always operate tractor PTO at proper RPM (540 or 1000 depending on model) to maintain blade speed and to produce a clean cut.

Under certain conditions tractor tires may roll down some grass and prevent cutting at the same height as the surrounding area. When this occurs, reduce your ground speed but maintain PTO at 540 or 1000 RPM. The lower ground speed will permit grass to rebound partially.

Mowing Tips

⚠ WARNING

- Look down and to the rear and make sure area is clear before operating in reverse.
- Do not operate or transport on steep slopes.
- Do not stop, start, or change directions suddenly on slopes.
- Use extreme care and reduce ground speed on slopes and rough terrain.
- Watch for hidden hazards on the terrain during operation.

⚠ CAUTION

- Stop power unit and equipment immediately upon striking an obstruction. Turn off engine, remove key, inspect, and repair any damage before resuming operation.

Maximum recommended ground speed for cutting or shredding is 6 miles per hour. Adjust tractor ground speed by using higher or lower gears to provide a clean cut without lugging tractor engine.

Tall material should be cut twice. Cut material higher the first pass. Cut at desired height at 90 degrees the second pass.

Remember, sharp blades produce cleaner cuts and use less power.

Before entering an area, analyze it to determine the best procedure. Consider the height and type of material to be cut and the terrain type (hilly, level or rough, etc.).

Shredding

The cutter may be used to shred various crops including green manure, straw, stubble, asparagus residue, corn stalks and similar crops in preparation for tilling. It may also be used to shred pruning in orchards, groves and vineyards.

Each shredding operation may require a different set-up. Start with front edge of cutter high. Adjust up or down as necessary with attitude rod. Experiment until you obtain the results you want.

When shredding attitude is set, check that the distance from the bottom rear edge of the wing to the ground matches the bottom edge of the rear center section to the ground. With the cutting height and attitude established, adjust the driveline carrier bearing in the H-frame to ensure the front driveline is parallel to the ground.

TRANSPORTING

⚠ WARNING

- Always raise unit and install transport locks before transporting. Leak down or failure of mechanical or hydraulic system can cause equipment to drop.
- Always attach safety chain to tractor drawbar when transporting unit.
- Never exceed 20 mph (32.2 km/h) during transport.
- Never allow riders on power unit or attachment.
- Do not operate PTO during transport.
- Do not operate or transport on steep slopes.
- Do not operate or transport equipment while under the influence of alcohol or drugs.

⚠ CAUTION

- Always comply with all state and local lighting and marking requirements.

Lock-Up

Always transport with wings and center frame in the raised, locked position. Place equipment on a level surface before raising wings.

Wing Lock-Up

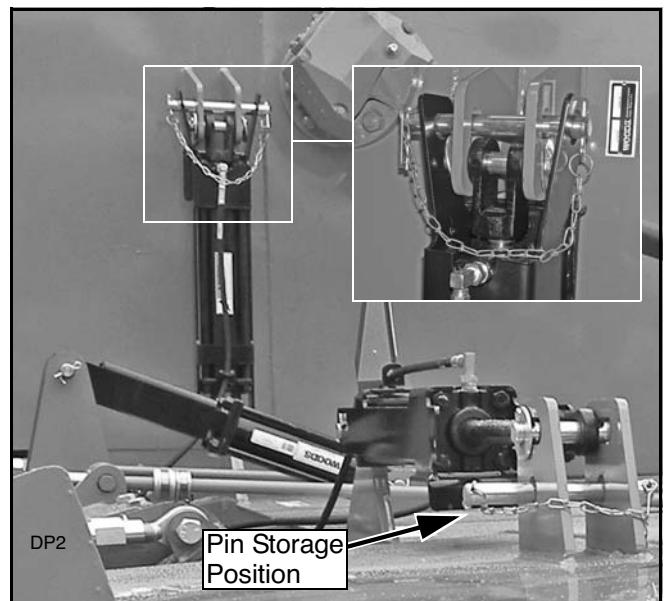

Figure 2. Transport Lock-Up
Wing and Center Section Shown

1. Remove safety pin and lock-up pin from storage position.

2. Raise wing and align wing transport lock with slotted holes in the cylinder lugs.
3. Insert lock-up pin above cylinder pin and secure with klik pin.
4. Repeat steps 1 to 3 for opposite wing.
5. Relieve hydraulic pressure from wing cylinders and lower wing against wing transport lock.

Center Section Lock-Up

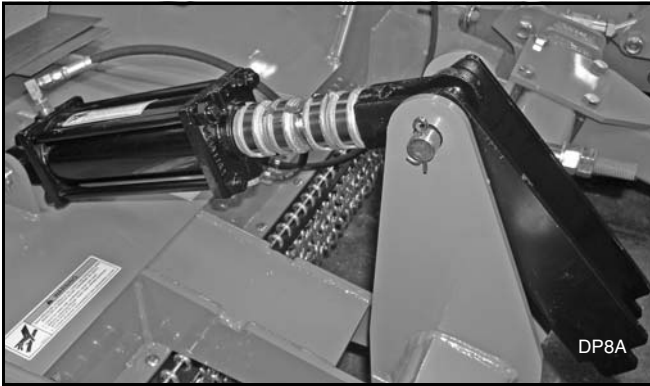

Figure 3. Transport Lock In Operation Position

1. Raise cutter with hydraulic cylinder to maximum height.
2. Rotate transport lock into position over cylinder rod (Figure 2).
3. Lower cutter against transport lock.
4. To lower cutter for operation, extend hydraulic cylinder to raise cutter. Rotate transport lock back away from cylinder rod (Figure 3).
5. Lower cutter to cutting height. Use cylinder stops (stroke control kit) to set desired cutting height.

STORAGE

Follow these steps when storing your cutter:

1. Clean cutter before storing. See page 24 for cleaning instructions. Store on level, solid ground.
2. Disconnect driveline and secure up off the ground.
3. Lower wings to ground.
4. Raise cutter center section and rotate transport lock into position over cylinder. Relieve hydraulic pressure.
5. Attach parking jack and raise tongue weight off tractor drawbar.
6. Place wedge blocks at front and rear of wheels on center section and each wing to prevent wheel rotation.
7. Securely block all four corners of center section and each wing with jack stands.

8. Remove hydraulic hoses after tractor is turned off and all system pressure is released by operating valve levers several times.
9. Remove safety tow chain from tractor.
10. Remove retainer pin and high strength drawbar pin.
11. Keep children and bystanders away from storage area.

PRE-OPERATION CHECK LIST

(OWNER'S RESPONSIBILITY)

- ___ Review and follow all safety rules and safety decal instructions on page 7 through page 13.
- ___ Check that all safety decals are installed and in good condition. Replace if damaged.
- ___ Check that equipment is properly and securely attached to tractor.
- ___ Make sure driveline spring-activated locking pin or collar slides freely and is seated firmly in tractor PTO spline groove.
- ___ Check all lubrication points and grease as instructed in lubrication information. Make sure the PTO slip joint is lubricated and that the gear-box fluid levels are correct.
- ___ Set tractor PTO at correct rpm for your equipment.
- ___ Check that all hydraulic hoses and fittings are in good condition and not leaking before starting tractor. Check that hoses are not twisted, bent sharply, kinked, frayed, or pulled tight. Replace any damaged hoses immediately.
- ___ Check that all hardware is properly installed and secured.
- ___ Check cutting height and attitude adjustment.
- ___ Raise and lower equipment to make sure air is purged from hydraulic cylinders and hoses.
- ___ Check that blades are sharp and secure and cutting edge is positioned to lead with correct rotation.
- ___ Make sure tractor ROPS or ROPS cab and seat belt are in good condition. Keep seat belt securely fastened during operation.
- ___ Check that shields and guards are properly installed and in good condition. Replace if damaged.
- ___ Before starting engine, operator must be in tractor seat with seat belt fastened. Place transmission in neutral or park, engage brake and disengage tractor PTO.

- ___ Inspect area to be cut and remove stones, branches, or other hard objects that might be thrown and cause injury or damage.
- ___ Inspect rubber or chain shielding and replace any damaged rubber shield or missing links.
- ___ Make sure tractor 3-point lift links do not interfere with hydraulic hoses or driveline throughout full turning range.
- ___ Check the tire pressure for pneumatic tires. The maximum pressure allowed is 40 psi.

OWNER SERVICE

The information in this section is written for operators who possess basic mechanical skills. If you need help, your dealer has trained service technicians available. For your protection, read and follow the safety information in this manual.

WARNING

- Keep all persons away from operator control area while performing adjustments, service, or maintenance.
- Before working underneath, disconnect driveline from tractor, lower wings to the ground, raise cutter, and engage transport lock-up in the locked position. Attach parking jack and lower to the ground. Securely block all four corners of the center section and each wing with jackstands. Blocking up prevents the cutter from dropping due to hydraulic leak down, hydraulic system failure, or mechanical component failure.
- Service and maintenance work not covered in **OWNER SERVICE** must be done by a qualified dealership. Special skills, tools, and safety procedures may be required. Failure to follow these instructions can result in serious injury or death.
- Before servicing, adjusting, repairing or unplugging, stop tractor engine, place all controls in neutral, set park brake, remove ignition key, and wait for all moving parts to stop.
- Never perform service or maintenance with engine running.

CAUTION

- If you do not understand any part of this manual and need assistance, see your dealer.
- Always wear relatively tight and belted clothing to avoid entanglement in moving parts. Wear sturdy, rough-soled work shoes and protective equipment for eyes, hair, hands, hearing, and head; and respirator or filter mask where appropriate.

BLOCKING METHOD

To minimize the potential hazards of working underneath the cutter, follow these procedures:

WARNING

- Before performing any service or maintenance, lower equipment to ground or block securely, turn off engine, remove key, and disconnect driveline from tractor PTO.
- Never go underneath equipment (lowered to the ground or raised) unless it is properly blocked and secured. Never place any part of the body underneath equipment or between moveable parts even when the engine has been turned off. Hydraulic system leak down, hydraulic system failures, mechanical failures, or movement of control levers can cause equipment to drop or rotate unexpectedly and cause severe injury or death. Follow Operator's Manual instructions for working underneath and blocking requirements or have work done by a qualified dealer.

Do not position jackstands under wheels, axles, or wheel supports. Components can rotate and cause cutter to fall.

1. Jackstands with a load rating of 1000 lbs. or more are the only approved blocking device for this cutter. Install jackstands (shown by Xs in Figure 4) under the cutter before working underneath unit.
2. Consider the overall stability of the blocked unit. Just placing jackstands underneath will not ensure your safety.

The working surface must be level and solid to support the weight on the jackstands. Make sure jackstands are stable, both top and bottom. Make sure cutter is approximately level.

3. With full cutter weight lowered onto jackstands, test blocking stability before working underneath.
4. If cutter is attached to tractor when blocking, set the brakes, remove key, and block cutter before working underneath.
5. Securely block rear tractor wheels, in front and behind. Tighten tractor lower 3-point arm anti-sway mechanism to prevent side-to-side movement.

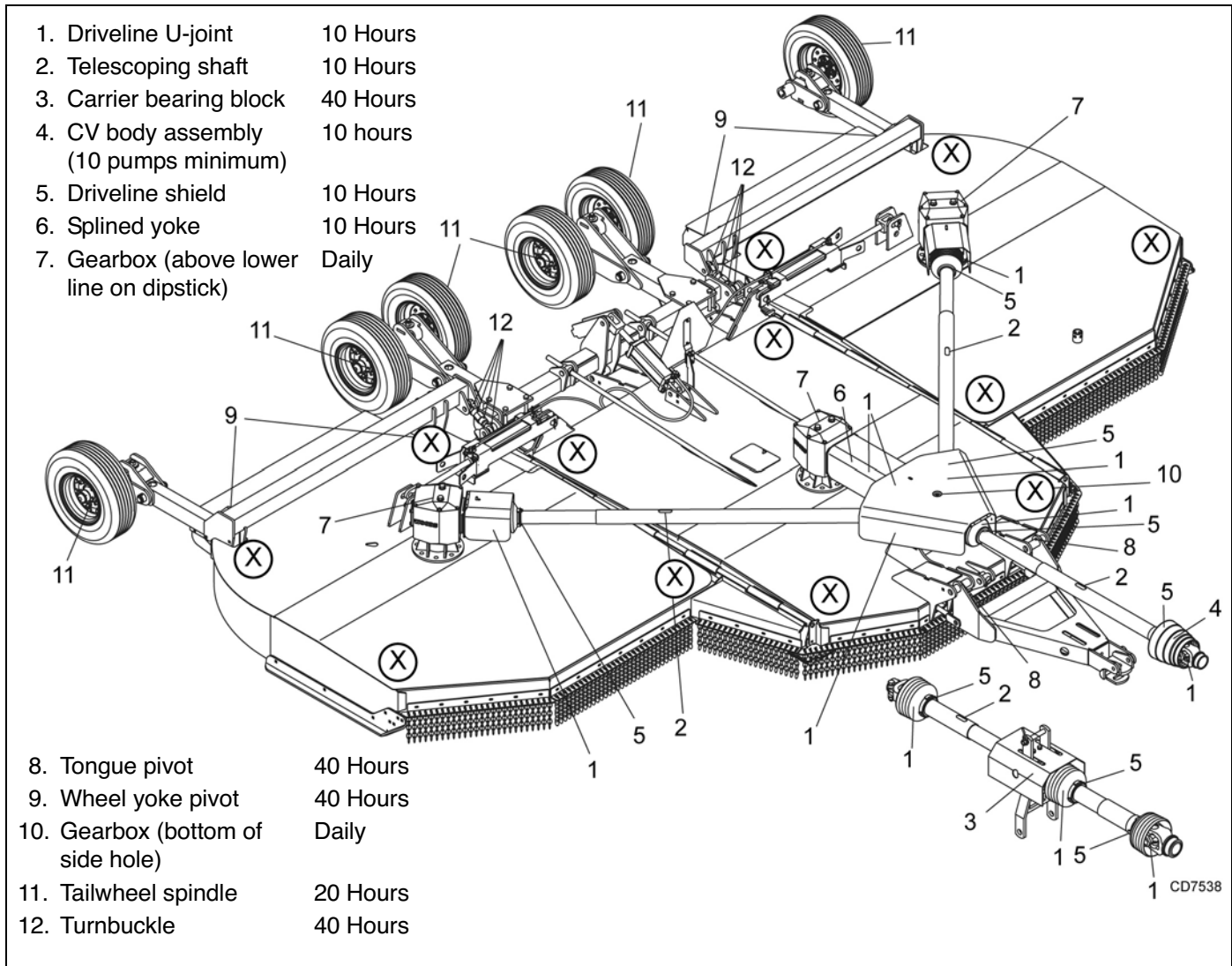

Figure 4. Jackstand Placement and Lubrication Points

LUBRICATION

Do not let excess grease collect on or around parts, particularly when operating in sandy areas.

See Figure 4 for lubrication points and frequency or lubrication based on normal operating conditions. Severe or unusual conditions may require more frequent lubrication.

Use a lithium grease of #2 consistency with a MOLY (molybdenum disulfide) additive for all locations unless otherwise noted. Be sure to clean fittings thoroughly before attaching grease gun. One good pump of most guns is sufficient when the lubrication schedule is followed.

Gearbox Lubrication

For gearbox, use a high quality gear oil with a viscosity index of 80W or 90W and an API service rating of GL-4 or -5 in gearboxes. **Splitter Gearbox;** Fill gearbox

until oil runs out the side plug on gearbox. **Wing Gearbox;** Fill gearbox until oil is just above lower line on dipstick. Check gearbox daily for evidence of leakage, and contact your dealer if leakage occurs. Use sealant on vent plug threads during installation. Check vent plug periodically and clean if it does not relieve pressure.

Driveline Lubrication

1. Lubricate the driveline slip joint every eight operating hours. Failure to maintain proper lubrication could result in damage to U-joints, gearbox, and driveline.
2. Lower cutter to ground, disconnect driveline from tractor PTO shaft, and slide halves apart but do not disconnect from each other.
3. Apply a bead of grease completely around male half where it meets female half. Slide drive halves over each other several times to distribute grease.

Seasonal Lubrication

In addition to the daily recommended lubrication, a more extensive application is recommended seasonally.

1. Fill CV double yokes with 20 pumps of grease with the joints in a straight line.
2. Articulate CV body to maximum angle several times to ensure full coverage of joints.
3. Place joints in the straight position and add 10 additional pumps of grease to both joints.
4. Wipe telescoping drive clean of all old grease and contaminants.
5. Add a thin layer of new grease over telescoping drive.

BLADES

WARNING

■ Before working underneath, read manual instructions, securely block up, and check stability. Secure blocking prevents equipment from dropping due to hydraulic leak down, hydraulic system failure, or mechanical component failure.

Blade Removal (Figure 5)

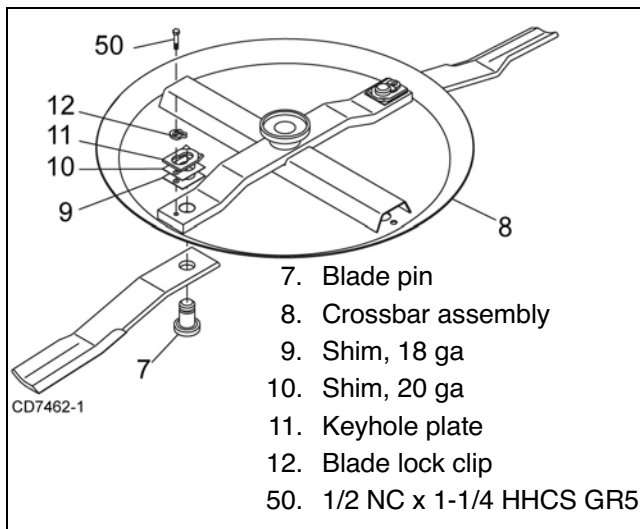

Figure 5. Blade Assembly

1. Disconnect driveline from tractor PTO.
2. Raise cutter and block securely (see Figure 4).
3. Align crossbar (8) with blade access hole in the cutter frame. Remove cap screw (50), blade pin

lock clip (12), keyhole plate (11), and shims (9 & 10). Carefully drive blade pin (7) out of crossbar.

4. Rotate crossbar and repeat for opposite blade.

NOTICE

■ If blade pin (7) is seized in crossbar and extreme force will be needed to remove it, support crossbar from below to prevent gearbox damage.

Blade Installation (Figure 5)

CAUTION

■ Your dealer can supply genuine replacement blades. Substitute blades may not meet original equipment specifications and may be dangerous.

NOTICE

■ Crossbar rotation has clockwise rotation on left gearbox and counterclockwise rotation on the right and center gearboxes when looking down on cutter. Be sure to install blade cutting edge to lead in correct rotation.

NOTE: Always replace or sharpen both blades at the same time.

1. Inspect blade pin (7) for nicks or gouges, and if you find any, replace the blade pin.
2. Insert blade pin through the blade. Blade should swivel on blade pin; if it doesn't, determine the cause and correct.
3. Align crossbar (8) with blade access hole in cutter frame. Apply a liberal coating of Never-Seez[®] or equivalent to blade pin and crossbar hole. Make sure blade offset is down away from cutter.
4. Insert blade pin (7) through blade. Push blade pin through crossbar.
5. Install shims (9 & 10) over blade pin.

NOTE: Only use enough shims to allow keyhole plate (11) to slide into blade pin groove.

6. Install blade clip (12) over keyhole plate and into blade pin groove.
7. Secure into position with cap screw (50). Torque cap screw to 85 lbs-ft.
8. Repeat steps for opposite side.

NOTE: Blade should be snug but should swivel on pin without having to exert excessive force. Blade should not move more than a 1/4 inch up or down at the tip. Keep any spacers not used in the installation as replacements or for future installation.

Blade Sharpening

NOTICE

■ When sharpening blades, grind the same amount on each blade to maintain balance. Replace blades in pairs. Unbalanced blades will cause excessive vibration, which can damage gearbox bearings. Vibration may also cause structural cracks to cutter.

1. Sharpen both blades at the same time to maintain balance. Follow original sharpening pattern.
2. Do not sharpen blade to a razor edge—leave at least a 1/16" blunt edge.
3. Do not sharpen back side of blade.

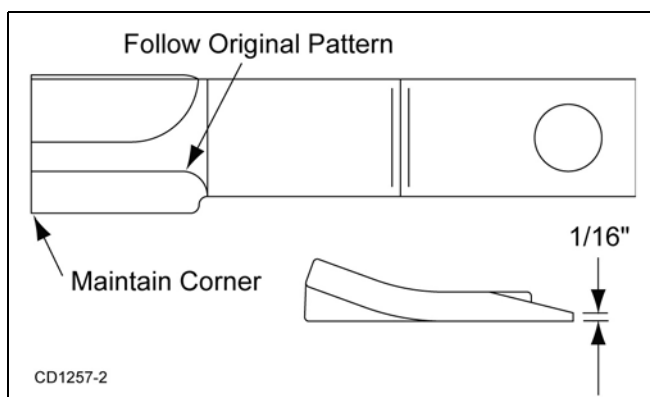

Figure 6. Blade Sharpening

SLIP CLUTCH ADJUSTMENT (Figure 7)

The slip clutch is designed to slip so that the gearbox and driveline are protected if the cutter strikes an obstruction.

A new slip clutch or one that has been in storage over the winter may seize. Before operating the cutter, make sure it will slip by performing the following operation:

1. Turn off tractor engine and remove key.
2. Remove driveline from tractor PTO.
3. Loosen six 10 mm cap screws (6) to remove all tension from Belleville spring plate (5).
4. Hold clutch hub (3) solid and turn shaft to make sure clutch slips.
5. If clutch does not slip freely, disassemble and clean the thrust plate faces (4), flange yoke (1), and clutch hub (3).
6. Reassemble clutch.
7. Tighten Belleville spring plate (5) until it is against the thrust plate (4) of the clutch, and then back off each of the six nuts by 2 full revolutions. The gap between Belleville spring plate and thrust plate should be 1/8" as shown in Figure 7.
8. If a clutch continues to slip when the spring is compressed to 1/8" gap, check friction discs (2) for excessive wear. Discs are 1/8" when new. Replace discs after 1/16" wear. Minimum disc thickness is 1/16".

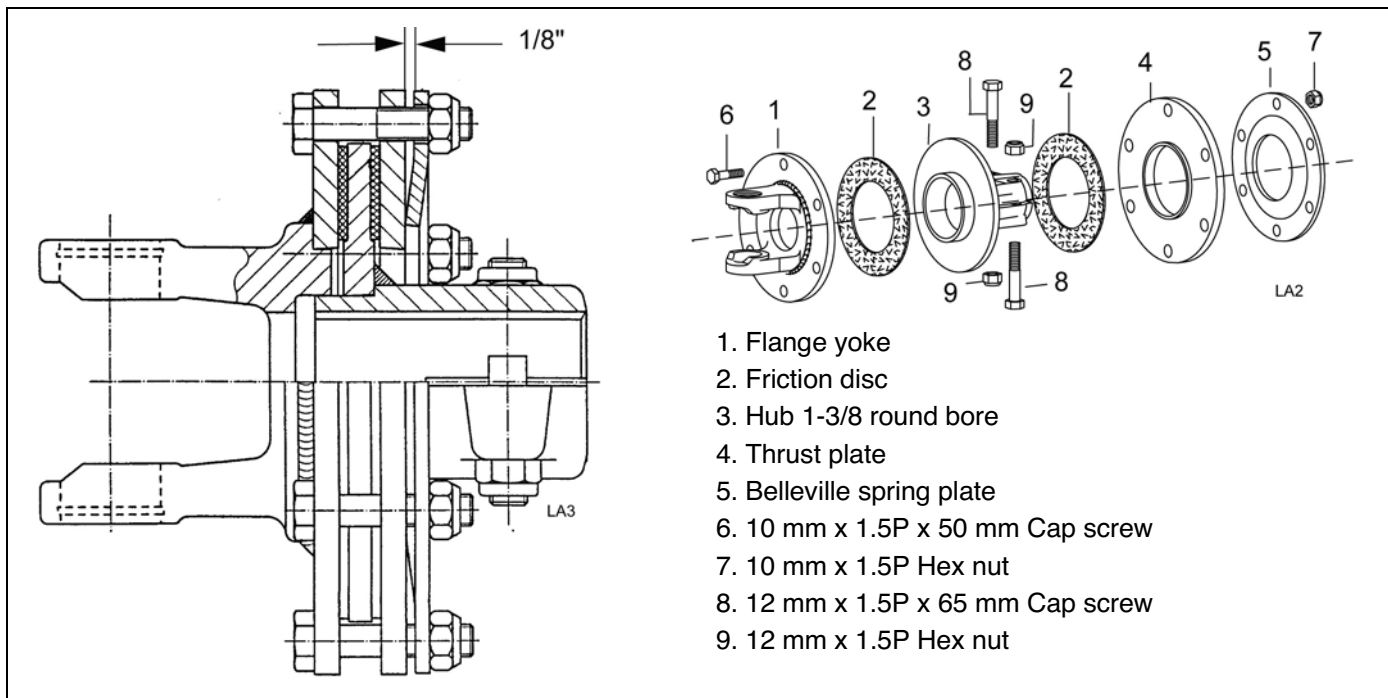

Figure 7. Slip Clutch Assembly

SHIELDING REPAIR

DANGER

■ Full chain or rubber shielding must be installed when operating in populated areas or other areas where thrown objects could injure people or damage property.

- If this machine is not equipped with full chain or rubber shielding, operation must be stopped when anyone comes within 300 feet (92 m).
- This shielding is designed to reduce the risk of thrown objects. The mower deck and protective devices cannot prevent all objects from escaping the blade enclosure in every mowing condition. It is possible for objects to ricochet and escape, traveling as much as 300 feet (92 m).

Repairing Rubber Shielding

1. Inspect belting and rear bands each day of operation.
2. Replace if bent, cracked, or broken.
3. Replace any missing hardware.

Repairing Optional Chain Shielding:

1. Inspect chain shielding each day of operation and replace any broken or missing chains as required.
2. Replace any missing hardware.

SERVICE TIRES SAFELY

Used Aircraft Tires (Figure 8)

WARNING



■ Explosive separation of tire and rim parts can cause serious injury or death. Release all air pressure before loosening bolts.

Do not attempt to mount a tire unless you have the proper equipment and experience to perform the job.

Always maintain the correct tire pressure. Do not inflate tires above the recommended pressure. Never weld or heat a wheel and tire assembly. The heat can cause an increase in air pressure and result in a tire explosion. Welding can structurally weaken or deform the wheel.

When inflating tires, use a clip-on chuck and an extension hose long enough to allow you to stand to the side — not in front of or over the tire assembly. Use a safety cage if available.

Check wheels for low pressure, cuts, bubbles, damaged rims, or missing lug bolts and nuts.

Never remove split rim assembly hardware (A) with the tire inflated.



Figure 8. Split Rim Tire Servicing

CLEANING

After Each Use

- Remove large debris such as clumps of dirt, grass, crop residue, etc. from machine.
- Inspect machine and replace worn or damaged parts.
- Replace any safety decals that are missing or not readable.

Periodically or Before Extended Storage

- Clean large debris such as clumps of dirt, grass, crop residue, etc. from machine.
- Remove the remainder using a low-pressure water spray.
 1. Be careful when spraying near scratched or torn safety decals or near edges of decals as water spray can peel decal off surface.
 2. Be careful when spraying near chipped or scratched paint as water spray can lift paint.
 3. If a pressure washer is used, follow the advice of the pressure washer manufacturer.
- Inspect machine and replace worn or damaged parts.
- Sand down scratches and the edges of areas of missing paint and coat with Woods spray paint of matching color (purchase from your Woods dealer).
- Replace any safety decals that are missing or not readable (supplied free by your Woods dealer). See Safety Decals section for location drawing.

TROUBLESHOOTING

PROBLEM	POSSIBLE CAUSE	SOLUTION
Does not cut	Dull blades Worn or broken blades Incorrect PTO speed Ground speed too fast Drive not functioning (blades do not turn when PTO is running) Gearbox malfunction Excessive clutch slippage Incorrect blade direction	Sharpen blades. Replace blades. (Replace in pairs only.) Set at rated PTO speed. Reduce ground speed. Check drive shaft connection. Check gearbox. Repair gearbox. Adjust clutch. Check to be sure blade edge is correct for direction of rotation.
Streaks or ragged cut	Broken or worn blades Attitude incorrect Ground speed too fast Excessive cutting height Excessive lush and tall vegetation	Replace or sharpen blades. Level machine. Reduce ground speed. Lower cutting height. (Note: Set height so blades do not frequently hit ground.) Recut at 90° to first pass.
Excessive side skid wear	Running with skids continuously on ground	Raise cutting height or adjust.
Excessive clutch slippage	Clutch out of adjustment Clutch discs worn; wear stops contacting opposite plate Blades hitting ground	Adjust clutch. Replace discs. Raise cutting height.
Vibration	Broken blade Bearing failure Hitch length incorrect Universal drive	Replace blades in pairs. Check gearbox shafts for side play. Reset hitch length. Adjust pedestal bearing height to be parallel to ground.
Blades hitting deck	Bent blades or crossbar	Replace bent blades or crossbar.
Unit will not raise	Low oil	Add hydraulic oil.
Unit doesn't cut level	Wing section cuts lower than center Wing section cuts higher than center	Lengthen turnbuckle connecting center yoke to wing wheel yoke. Shorten turnbuckle connecting center yoke to wing wheel yoke.

DEALER SERVICE

The information in this section is written for dealer service personnel. The repair described here requires special skills and tools. If your shop is not properly equipped or your mechanics are not properly trained in this type of repair, you may be time and money ahead to replace complete assemblies.

WARNING

- Before working underneath, read manual instructions, securely block up, and check stability. Secure blocking prevents equipment from dropping due to hydraulic leak down, hydraulic system failure, or mechanical component failure.
- Keep all persons away from operator control area while performing adjustments, service, or maintenance.

CAUTION

- Always wear relatively tight and belted clothing to avoid getting caught in moving parts. Wear sturdy, rough-soled work shoes and protective equipment for eyes, hair, hands, hearing, and head; and respirator or filter mask where appropriate.

GEARBOX MAINTENANCE

NOTE: Read this entire section before starting any repair. Many steps are dependent on each other.

1. Fill gearbox with SAE 80W or 90W gear lube. Proper oil level is between lowest ring and end of dipstick.

NOTE: Repair to this gearbox is limited to replacing bearings, seals, and gaskets. Replacing gears, shafts, and a housing is not cost effective. Purchasing a complete gearbox is more economical.

2. Inspect gearbox for leakage and bad bearings. Leakage is a very serious problem and must be corrected immediately.

NOTE: Bearing failure is indicated by excessive noise and side-to-side or end-play in gear shafts.

Seal Replacement (Figure 9)

Recommended sealant for gearbox repair is Permatex® Aviation 3D Form-A-Gasket or equivalent.

Leakage can occur at the vertical or horizontal gaskets and shaft seals.

Leakage at the horizontal gasket or seal can be repaired without removing the gearbox from the cutter.

Seal Installation

NOTE: Proper seal installation is important. An improperly installed seal will leak.

1. Clean area in housing where seal outer diameter (OD) seats. Apply a thin coat of Permatex.
2. Inspect area of shaft where seal seats. Remove any burrs or nicks with an emery cloth.
3. Lubricate gear shaft and seal lips.
4. Place seal squarely on housing, spring-loaded lip toward housing. Select a piece of pipe or tubing with an OD that will sit on the outside edge of the seal but will clear the housing. Tubing with an OD that is too small will bow seal cage and ruin seal.
5. Carefully press seal into housing, avoiding distortion to the metal seal cage.

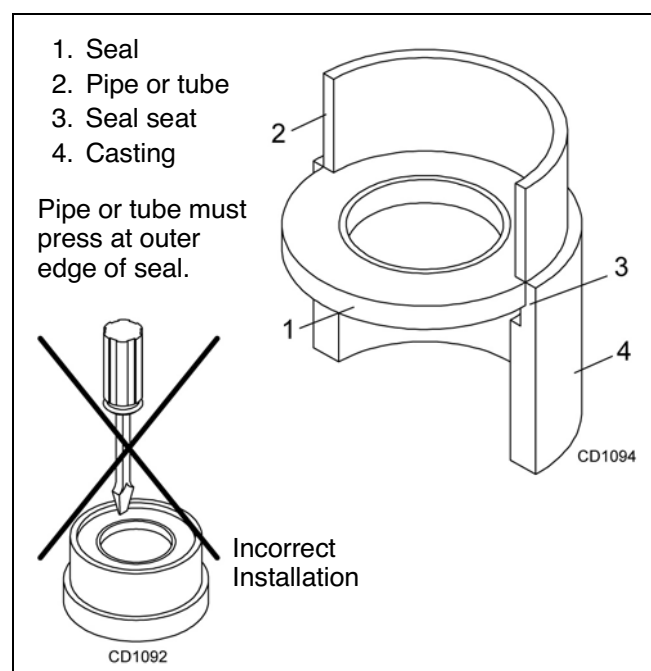

Figure 9. Seal Installation

Vertical Shaft Seal Replacement (Figure 10)

1. Disconnect and remove the rear driveline from the gearbox.
2. Remove vent plug (24) and siphon gear lube from housing through this opening.
3. Remove crossbar (see page 31).
4. Remove protective seal (8) and vertical shaft seal (18). Replace seal (18) with new seal.

Vertical seal should be recessed in housing. Horizontal seal (19) should be pressed flush with outside of housing.

NOTE: Distortion to seal cage or damage to seal lip will cause seal to leak.

5. Fill gearbox with SAE 80W or 90W gear lube until it runs out the level plug.
6. Remove and replace any seal damaged in installation.

Horizontal Shaft Seal Replacement (Figure 10)

1. Disconnect and remove the rear driveline from the gearbox.
2. Remove vent plug (24) and siphon gear lube from housing through this opening.
3. If the leak occurred at either end of horizontal shaft, remove oil cap (20) and/or oil seal (19). Replace with new one.
4. Fill gearbox with SAE 80W or 90W gear lube until it runs out the level plug.

GEARBOX REPAIR

Removal from Cutter (Figure 10)

NOTE: Gearbox is heavy: do not attempt to move without mechanical assistance.

1. Disconnect and remove the rear driveline from the gearbox.
2. Remove cotter pin and nut from vertical shaft and remove crossbar (see page 31).
3. Remove the six bolts that attach gearbox to cutter and remove gearbox.

Disassembly (Figure 10)

1. Remove top cover (22) from gearbox and pour out gear oil.
2. Remove oil cap (20) (to be replaced).
3. Remove snap ring (10) and shim (13) from input shaft (3).
4. Support gearbox in hand press and push on input shaft (3) to remove bearing (7).

5. Remove six cap screws (23) and top cover (22) from housing. Remove gear (1) from inside housing.
6. Remove oil seal (19) from front of housing (to be replaced).
7. Remove snap ring (10) and shim (13) from front of housing (2).
8. Remove input bearing (7) by using a punch and hammer from outside of housing.
9. Support housing in vise in a horizontal position.
10. The castle nut (15), cotter pin (25), and hub are already removed with the stump jumper/crossbar. Remove the protective seal (8), and oil seal (18).
11. Remove cotter pin (9), castle nut (14), and shim (17) from output shaft (4).
12. Remove output shaft (4) by using a punch and hammer and tap on top to drive down. Remove gear (5) and shim (16) from inside housing.
13. Remove bottom bearing (26) by using a punch and hammer from the top, outside the housing.
14. Support housing upside down (top cover surface) and remove bearing (6) by using a punch and hammer from the bottom side of the housing.
15. Inspect gears for broken teeth and wear. Some wear is normal and will show on loaded side. Forged gear surfaces are rough when new. Check that wear pattern is smooth.
16. Inspect vertical and horizontal shafts for grooves, nicks, or bumps in the areas where the seals seat. Resurface any damage with emery cloth.
17. Inspect housing and caps for cracks or other damage.

Assembly (Figure 10)

1. Clean housing, paying specific attention to areas where gaskets will be installed.
2. Wash housing and all components thoroughly. Select a clean area for gearbox assembly. Replace all seals, bearings, and gaskets. All parts must be clean and lightly oiled before reassembling.
3. Insert both output bearings (6) in the housing, using a round tube of the correct diameter and a hand press.
4. Slide output shaft (4) through both bearings (26 & 6) until it rests against bearing (6).
5. Slide shim (16) over output shaft (4).
6. Press gear (5) onto output shaft (4) and secure with shim (17), castle nut (14), and cotter pin (9).
7. Apply grease to lower seal lips (18) and press seal (18) over output shaft (4), using a tube of the

correct diameter. Be sure not to damage the seal lip.

8. Press in housing so that seal is recessed. Press protective seal (8) until seated flush with housing. Verify that the seal (8) is seated correctly.
9. Press bearing (7) into the housing, using a round tube of the correct diameter and a hand press. Secure with shim (13) and snap ring (10).
10. Secure snap ring (11) on input shaft (3) if not already secure.
11. Place gear (1) through top of housing and align gear (1) and gear (5) so that gear teeth are a match.
12. While holding gear (1) in place, slide input shaft (3) through gear (1) and bearing (7). Align splines on shaft (3) and gear (1).
13. Slide shim (12) over input shaft (3) and press bearing (7) onto input shaft (3), using a round tube of the correct diameter and a hand press.
14. Slide shim (13) over input shaft (3) and secure with snap ring (10).
15. Check input shaft end float by moving the input shaft (3) by hand. If end float is higher than 0.012", insert shim between input shaft (3) and rear bearing (7). Repeat until end float is less than

0.012". Check rotational torque by hand. The torque should be less than 2.2 lbs-inch.

16. Check that the gear backlash is between 0.006" and 0.016". You should not have to adjust the backlash.
17. Press in input oil seal (19), using tube of correct diameter. Be careful not to damage seal lip.
18. Press oil cap (20) on to cover the rear of housing, using a tube of the correct diameter.
19. Place top cover (22) on top of housing and secure with six cap screw (23).
20. Check gearbox housing for leaks by plugging all holes except one. Apply 4 psi compressed air and immerse the gearbox in water to verify that there are no leaks.
21. Remove gearbox from water and dry off with compressed air. Add SAE 80W or 90W EP oil until it runs out of side level hole. Tighten all plugs.

Reinstallation

NOTE: Gearbox is heavy: do not attempt to move without mechanical assistance.

1. Set gearbox on cutter and fasten with bolts and nuts. Torque bolts to 300 lbs-ft.
2. Attach crossbar (Crossbar Installation, page 32).

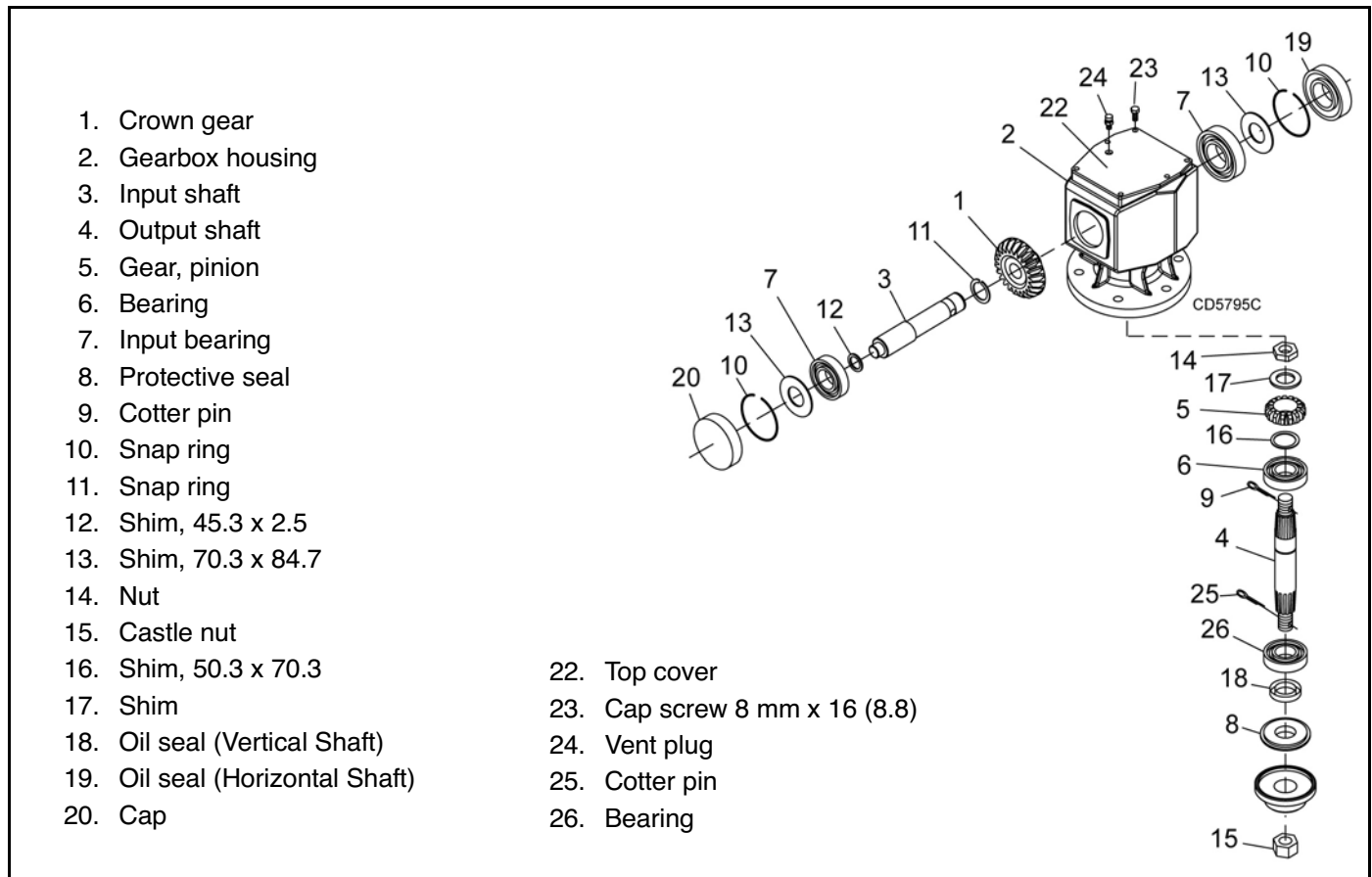

Figure 10. Gearbox

SPLITTER GEARBOX REPAIR (Figure 11)

Removal from Cutter

1. Disconnect and remove all drivelines from gearbox.
2. Remove the four cap screw and lock washers that secure gearbox to cutter, and remove gearbox.

NOTE: Gearbox is heavy: do not attempt to move it without mechanical assistance.

Disassembly

Center Shaft

1. Remove plug from side of gearbox and pour out the gear oil.
2. Remove seal (6, to be replaced) from the front and rear of the center shaft (5).
3. Remove front cap (4) and gaskets (8, 9, 10) from the front and rear of the center shaft (5).
4. Support gearbox in a hand press and push on the rear of the center shaft.
5. Remove bearing cones (7), and gear (18) from center shaft (5).
6. Remove bearing cups (7) from housing and cap using a punch and hammer.

Side Shaft

7. Remove seal (12, to be replaced) from the output shaft (13).
8. Remove 8 cap screws (3) and side shaft assembly.
9. Remove cotter pin (21), bearing adjustment nut (20), and gear (19).
10. Support side shaft assembly in hand press. Press shaft (13) through the cap (11) from the threaded end of the shaft.
11. Repeat steps 10 through 12 for opposite side shaft.

Inspect Components

12. Inspect gears for broken teeth and wear. Some wear is normal and will show on the loaded side of the teeth. Forged gear surfaces are rough when new. Check that wear pattern is smooth.
13. Inspect shafts for grooves, nicks, or bumps in the areas where seals seat. Resurface any damage with emery cloth or replace shaft.
14. Inspect housing and caps for cracks or other damage.

Assembly

1. Clean housing, pay specific attention to areas where gaskets are installed.
2. Wash housing and all components thoroughly.
3. Select a clean work area to assemble gearbox.
4. Replace all seals, bearings, and gaskets.
5. All parts must be clean and lightly oiled before assembly.

Side Shaft

6. Insert bearing cups (7) in hub cap (11) using a round tube of the same size diameter and a hand press.
7. Press bearing cone (7) on to output shaft (13), slide output shaft (13) through hub cap (11) and press bearing cone (7) on to output shaft (13).
8. Slide gear (19) over output shaft (13) and secure with nut (20) and cotter pin (21).
9. Check end play of shaft by moving it in and out. If end play is more than 0.012", tighten nut (20). Repeat process until end play is less than 0.012".
10. Check rotational torque. Torque should be less than 2.2 lbs-inch gear.
11. Place seal (12) over shaft and press into housing using a tube of the same diameter. Seal should be flush with housing when properly installed.
12. Repeat steps 6 through 10 for opposite side shaft.

Center Shaft

13. Insert bearing cups (7) in housing and front cap (4) using a round tube of the same size diameter and a hand press.
14. Press spacer (14), gear (18), shims (15, 16, 17) and bearing cones (7) on to input shaft (5).
15. Slide input shaft (5) through housing and install gaskets (8, 9, 10) and cap (4).
16. Check end play of shaft by moving it in and out. If end play is more than 0.012", remove a gasket (8, 9, or 10). Repeat process until end play is less than 0.012".
17. Check rotational torque. Torque should be less than 2.2 lbs-inch gear.
18. Check gear backlash, backlash should be between 0.006" and 0.016". Adjust the backlash by adding or removing shims (15, 16, 17) from the input shaft (5).
19. Place seal (6) over shaft and press into housing using a tube of the same diameter. Seal should be flush with housing when properly installed. Repeat process for opposite end shaft.

Gearbox Inspection

1. Check gearbox for leaks by: plugging all holes except one, applying 4 psi of compressed air, and immersing gearbox in water. Verify gearbox does not leak.

NOTE: Excessive air pressure will damage seals.

2. Remove gearbox from water and dry off.
3. Remove upper plug on right side of housing. Add SAE 80W or 90W EP oil until it runs out side level hole. Replace plug.

4. Install breather (24) in top cover.

Gearbox Installation

NOTE: Gearbox is heavy: do not attempt to move it without mechanical assistance.

1. Place gearbox on cutter and secure into position using four cap screws and lock washers.
2. Torque hardware to 300 lbs-ft.
3. Attach all drivelines to gearbox.
4. Install all shields.

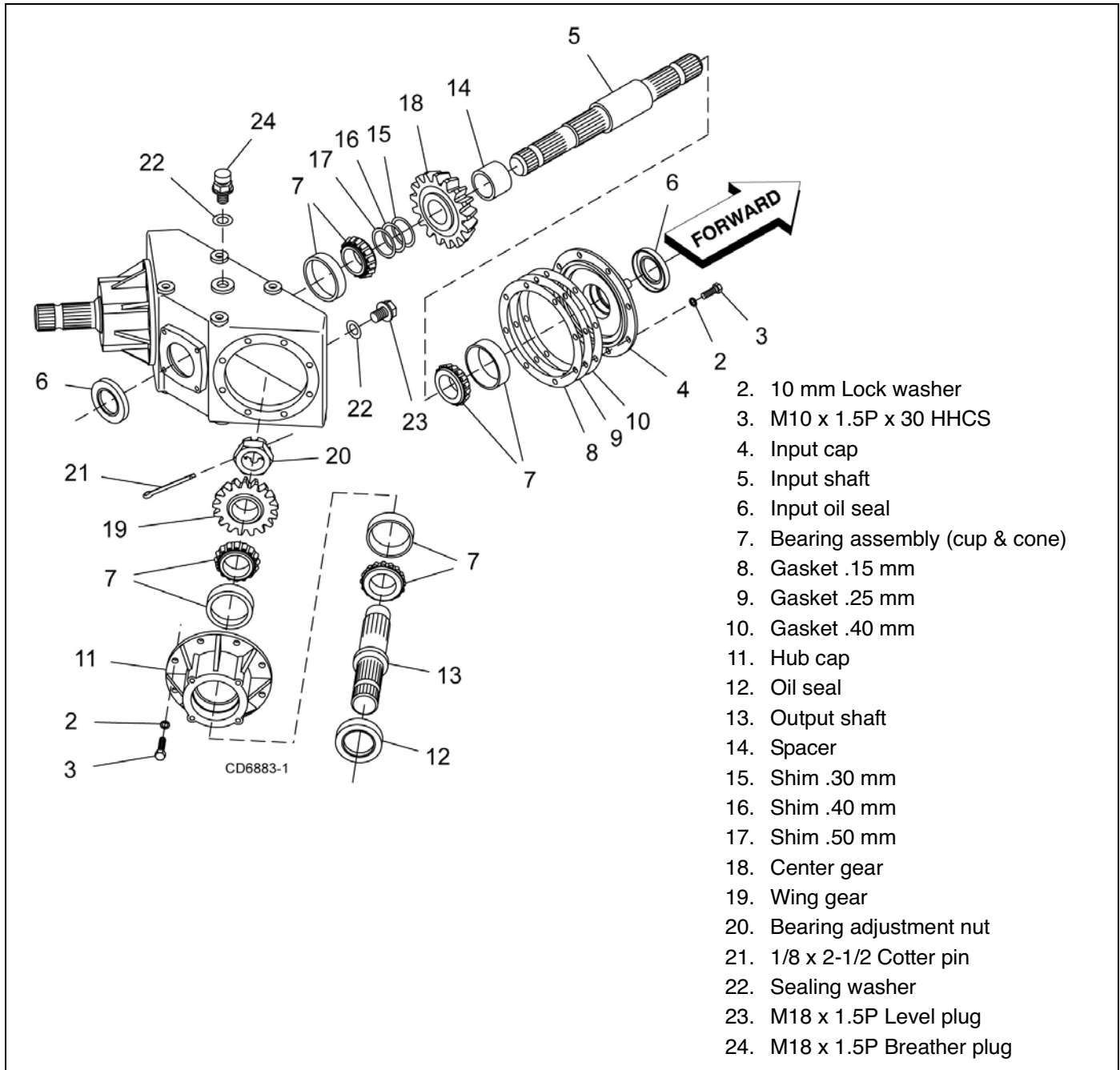

Figure 11. Splitter Gearbox Assembly

CROSSBAR REMOVAL

1. It is necessary to gain access to bottom side of cutter for crossbar removal. See Blocking Method page 20.

NOTE: You will need to use either the puller screw (Item 6, Figure 13) or a small hydraulic jack to remove the crossbar.

2. Remove blades from crossbar as shown in Figure 12.

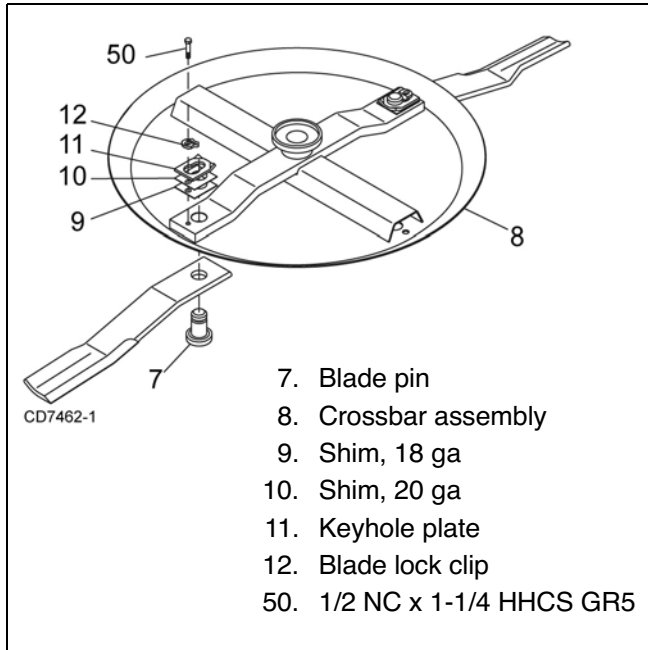

Figure 12. Blade Removal

3. Remove cotter pin from bottom of crossbar and remove nut and washer.

4. Refer to Figure 13. Attach a clevis (1) to each end of crossbar, using blade pins, spacers, keyhole plates, and blade pin clips.

5. Position tube assembly (5) with threaded nut (4) toward crossbar for puller screw removal or down for hydraulic jack removal.

6. For removal with puller screw, attach tube (5) to each clevis with bolts (2) and nuts (3). Place pad (4) in nut and thread puller screw (6) into nut from bottom. Tighten until pad is solid against gearbox shaft. For best results, strike head of puller screw with a hammer while tightening with a wrench.

7. For removal with a jack, attach tube to each clevis with puller links (7), bolts (2), and nuts (3). Place jack on tube with end of jack pressing against gearbox shaft. Slowly apply force with jack.

NOTE: Hydraulic jack will not operate if tipped more than 90°. Use care to prevent bending crossbar during removal.

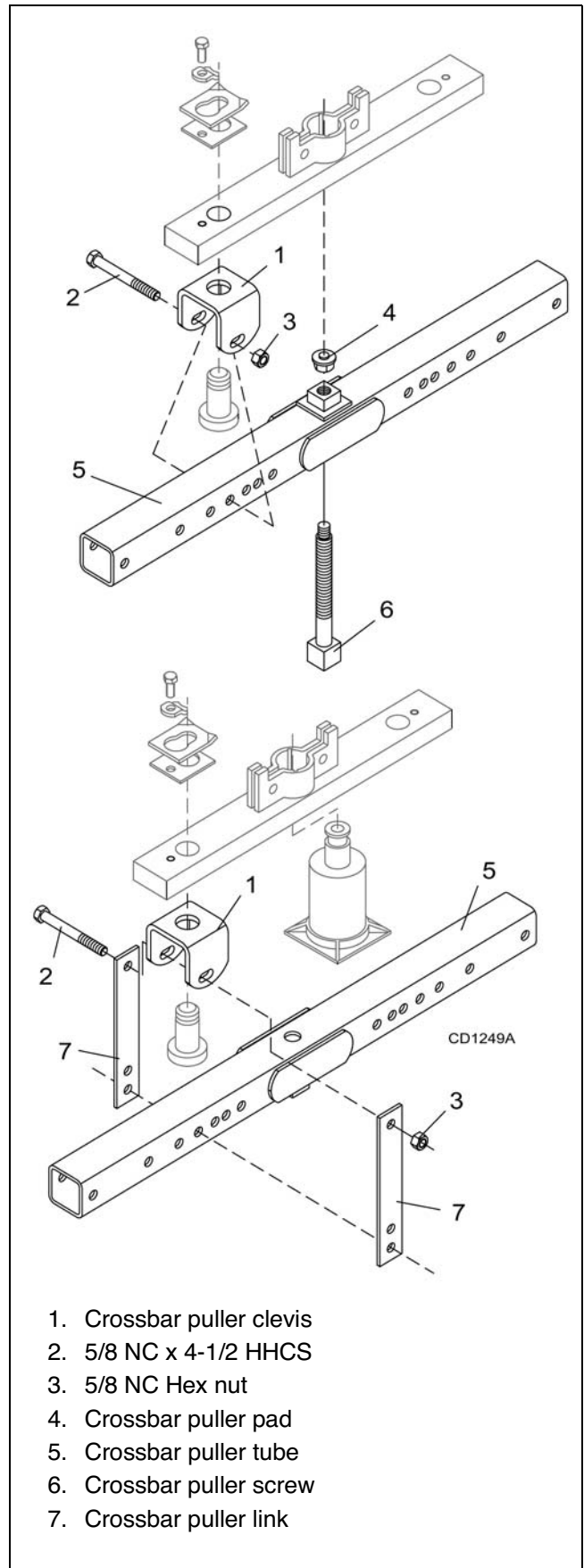

Figure 13. Crossbar Removal

CROSSBAR INSTALLATION

1. Using emery cloth (220 or finer), remove surface rust, Loctite® and foreign material from hub, splined gearbox vertical shaft, and crossbar assembly.
2. Slide crossbar assembly (8) onto splined shaft. Install nut (69) and align a slot with hole in splined shaft. Torque nut to 800 lbs-ft.
3. Install cotter pin (70) through slot in nut and bend ends over.

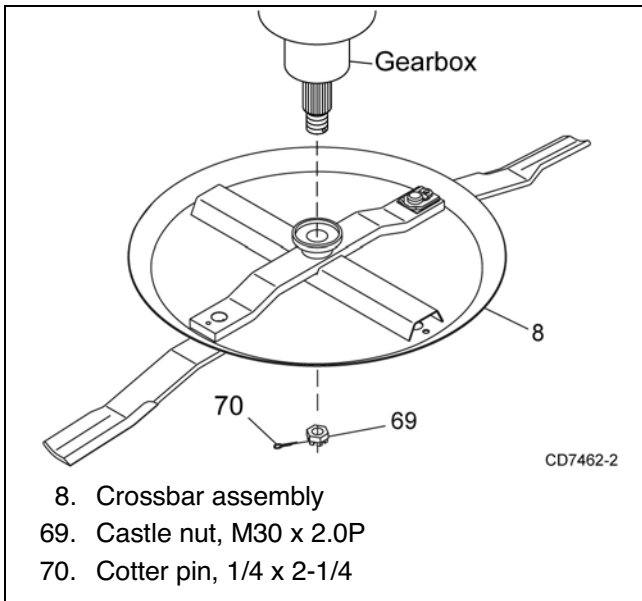

Figure 14. Crossbar Assembly Installation

UNIVERSAL JOINT REPAIR

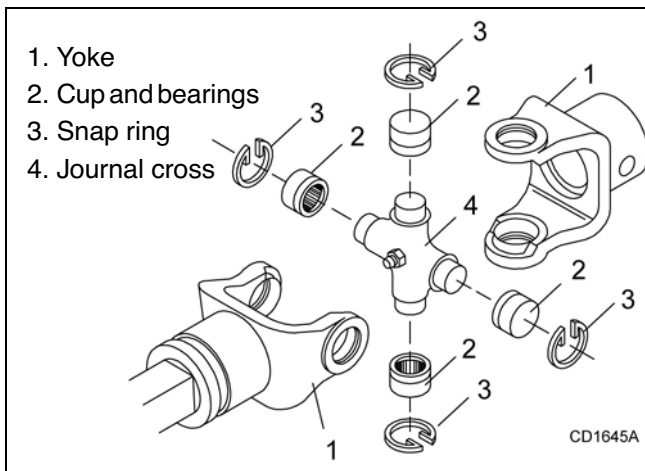

Figure 15. U-Joint Exploded View

U-Joint Disassembly

1. Remove external snap rings from yokes in four locations as shown in Figure 16.

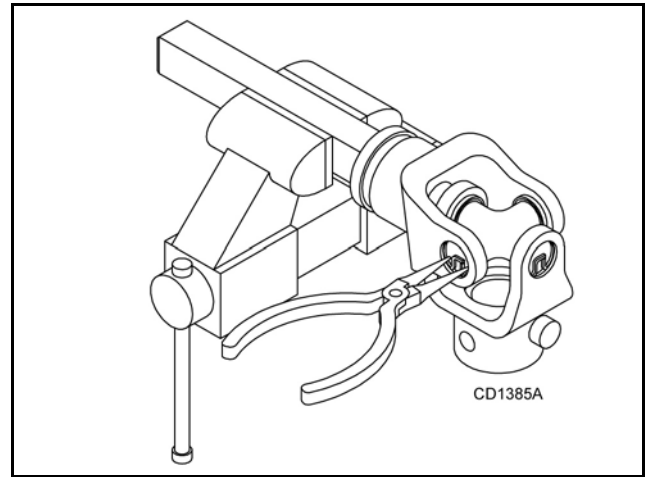

Figure 16

2. With snap rings removed, support drive in vise, hold yoke in hand and tap on yoke to drive cup up out of yoke. See Figure 17.

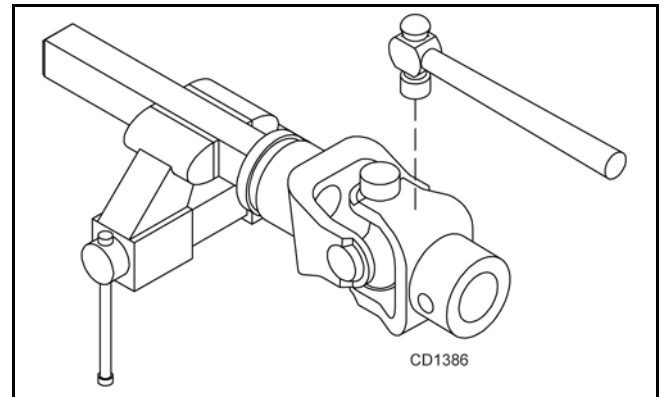

Figure 17

3. Clamp cup in vise as shown in Figure 18 and tap on yoke to completely remove cup from yoke. Repeat step 2 and step 3 for opposite cup.

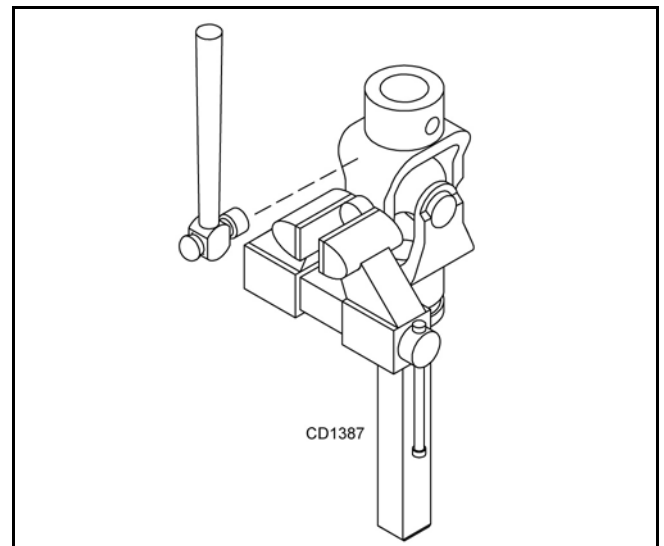

Figure 18

- Place universal cross in vise as shown in Figure 19 and tap on yoke to remove cup. Repeat Step 3 for final removal. Drive remaining cup out with a drift and hammer.

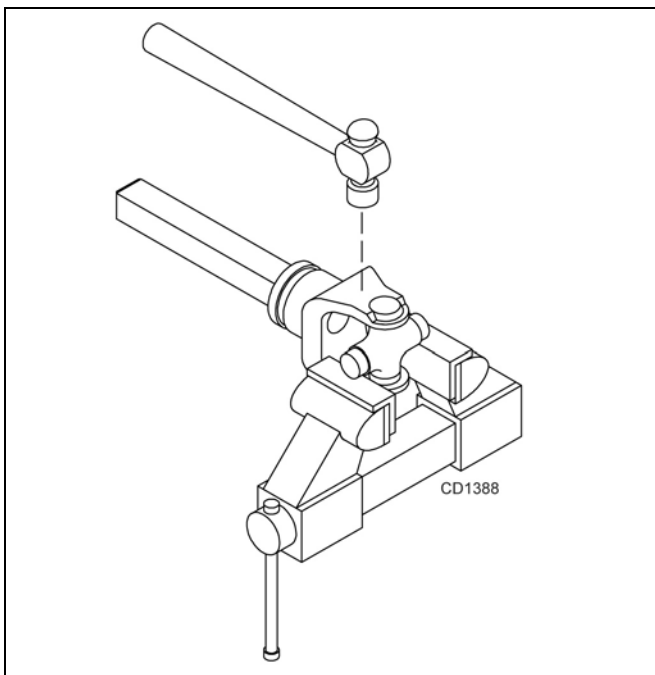

Figure 19

U-Joint Assembly

- Place seals securely on bearing cups. Insert cup into yoke from outside and press in with hand pressure as far as possible. Insert journal cross into bearing cup with grease fitting away from shaft. Be careful not to disturb needle bearings. Insert another bearing cup directly across from first cup and press in as far as possible with hand pressure.
- Trap cups in vise and apply pressure. Be sure journal cross is started into bearings and continue pressure with vise, squeezing in as far as possible. Tapping the yoke will help.
- Seat cups by placing a drift or socket (slightly smaller than the cup) on cup and rap with a hammer. Install snap ring and repeat on opposite cup.
- Repeat Step 1 and Step 2 to install remaining cups in remaining yoke.
- Move both yokes in all directions to check for free movement. If movement is restricted, rap on yokes sharply with a hammer to relieve any tension. Repeat until both yokes move in all directions without restriction.

SERVICE TIRES SAFELY

Used Aircraft Tires (Figure 20)

⚠ WARNING



Do not attempt to mount a tire unless you have the proper equipment and experience to perform the job.

Always maintain the correct tire pressure. Do not inflate tires above the recommended pressure. Never weld or heat a wheel and tire assembly. The heat can cause an increase in air pressure and result in a tire explosion. Welding can structurally weaken or deform the wheel.

When inflating tires, use a clip-on chuck and an extension hose long enough to allow you to stand to the side — not in front of or over the tire assembly. Use a safety cage if available.

Check wheels for low pressure, cuts, bubbles, damaged rims, or missing lug bolts and nuts.

Never remove split rim assembly hardware (A) with the tire inflated.

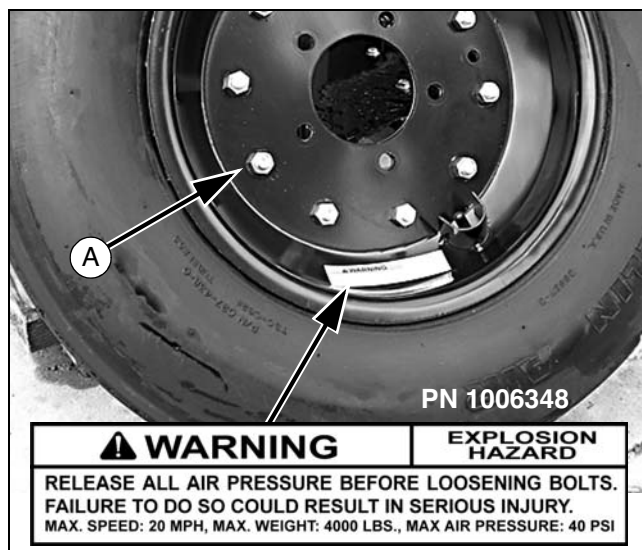

Figure 20. Split Rim Tire Servicing

ASSEMBLY INSTRUCTIONS

DEALER SET-UP INSTRUCTIONS

Assembly of this cutter is the responsibility of the WOODS dealer. It should be delivered to the owner completely assembled, lubricated and adjusted for normal cutting conditions.

The cutter is shipped partially assembled. Assembly will be easier if components are aligned and loosely assembled before tightening hardware. Recommended torque values for hardware are located on page 77.

Select a suitable working area. A smooth hard surface, such as concrete, will make assembly much quicker. Open parts boxes and lay out parts and hardware to make location easy. Refer to illustrations, accompanying text, parts lists and exploded view drawings.

Complete the check list on page 47 when assembly is complete and cutter is delivered to the customer.

WARNING

■ Before working underneath, carefully read Operator's Manual instructions, disconnect driveline, raise mower, securely block up all corners with jackstands, and check stability. Secure blocking prevents equipment from dropping due to hydraulic leak down, hydraulic system failures, or mechanical component failures.

■ Do not disconnect hydraulic lines until machine is securely blocked or placed in lowest position and system pressure is released by operating valve levers.

CAUTION

■ Always wear relatively tight and belted clothing to avoid entanglement in moving parts. Wear sturdy, rough-soled work shoes and protective equipment for eyes, hair, hands, hearing, and head; and respirator or filter mask where appropriate.

CENTER SECTION ASSEMBLY

Install Hydraulic Hoses

1. Insert one 264 inch (wing cylinder) hose and one 230 inch (center cylinder) hose into the right tube in the center section. Insert one 264 inch hose into the left tube.
2. Extend the 264" hoses approximately 52 inches past the back of the center section. Extend the 230" hose approximately 22 inches past the back of the center section.

3. Secure hose to center section using hose clamps (12), carriage bolts (59) and lock nuts (32). Clamps are used at the both front and at the rear of the deck.
4. Do not tighten clamps at this time. Hoses lengths may need to be adjusted once assembly is complete.

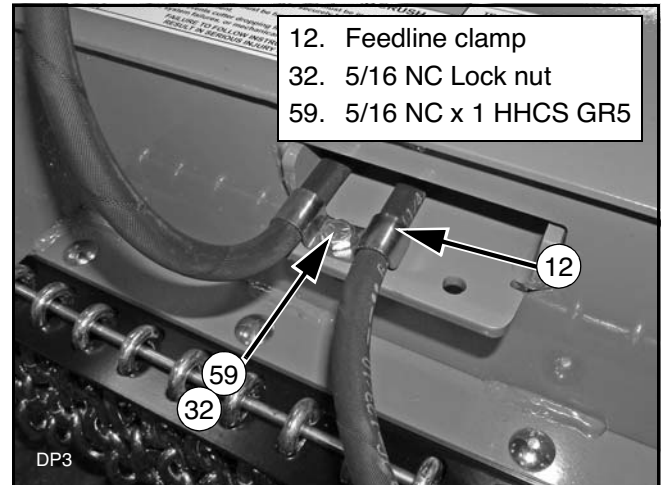

Figure 21. Hoses Clamped to Deck, Rear Right Side

Install Attitude Rods

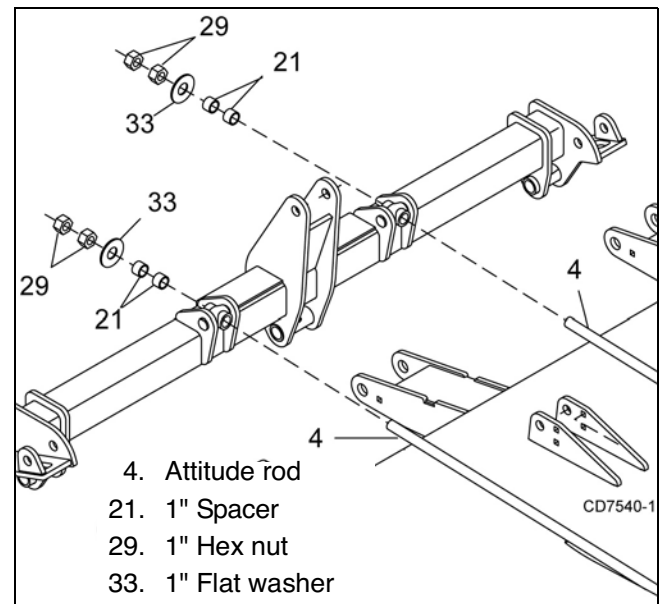

Figure 22. Attitude Rods Attached to Wheel Yoke

1. Insert attitude rods (4) through front of center section frame, out the center of the deck and through pivot casting in wheel yoke arm assembly. The rod is a very tight fit; use care to prevent thread damage during installation.
2. Slide spacers (21) over rods and install washers (33) and two nuts (34) per rod.

3. Tighten nuts until there is approximately 1 inches of thread exposed past the nuts. Further adjustment will be needed once cutter is attached to tractor drawbar. See Cutting Height Adjustment, page 15.

Install Height Adjustment Cylinder

Refer to Figure 23.

1. Attach base end of cylinder (3) to the cylinder lugs on the rear of the deck using clevis pin (18) and two cotter pins (63).
2. Extend cylinder rod and place transport lock bracket (5) over cylinder rod clevis.
3. Position cylinder rod and transport lock bracket between lugs on the wheel yoke tube and align holes.
4. Secure cylinder rod and transport lock bracket to the wheel yoke tube using clevis pin (19) and two cotter pins (63).
5. Install cylinder spacers (6) over cylinder rod as needed. Spacers are used to set cutting height.

6. Install bushing (24), elbow, (23) and hose (22) to the base end of cylinder (3).

NOTE: Make sure a breather fitting is installed in the rod end port of the wheel yoke cylinder.

7. An optional ratchet (7) is available, and replaces the hydraulic cylinder. Install ratchet jack using the same procedure and hardware used for the installation of the hydraulic cylinder.

Install SMV Emblem

Refer to Figure 23.

1. Attach SMV mounting bracket (8) to outside of left cylinder lug. Secure using two carriage bolts (67) and flange lock nuts (23).
2. Attach SMV socket (9) to mounting bracket (8) using two carriage bolts (36) and lock nuts (35).
3. Attach SMV emblem (11) to SMV bracket (10) using two round head cap screws (38) and hex nuts (39).

Insert SMV bracket (10) with emblem (11) into socket (9).

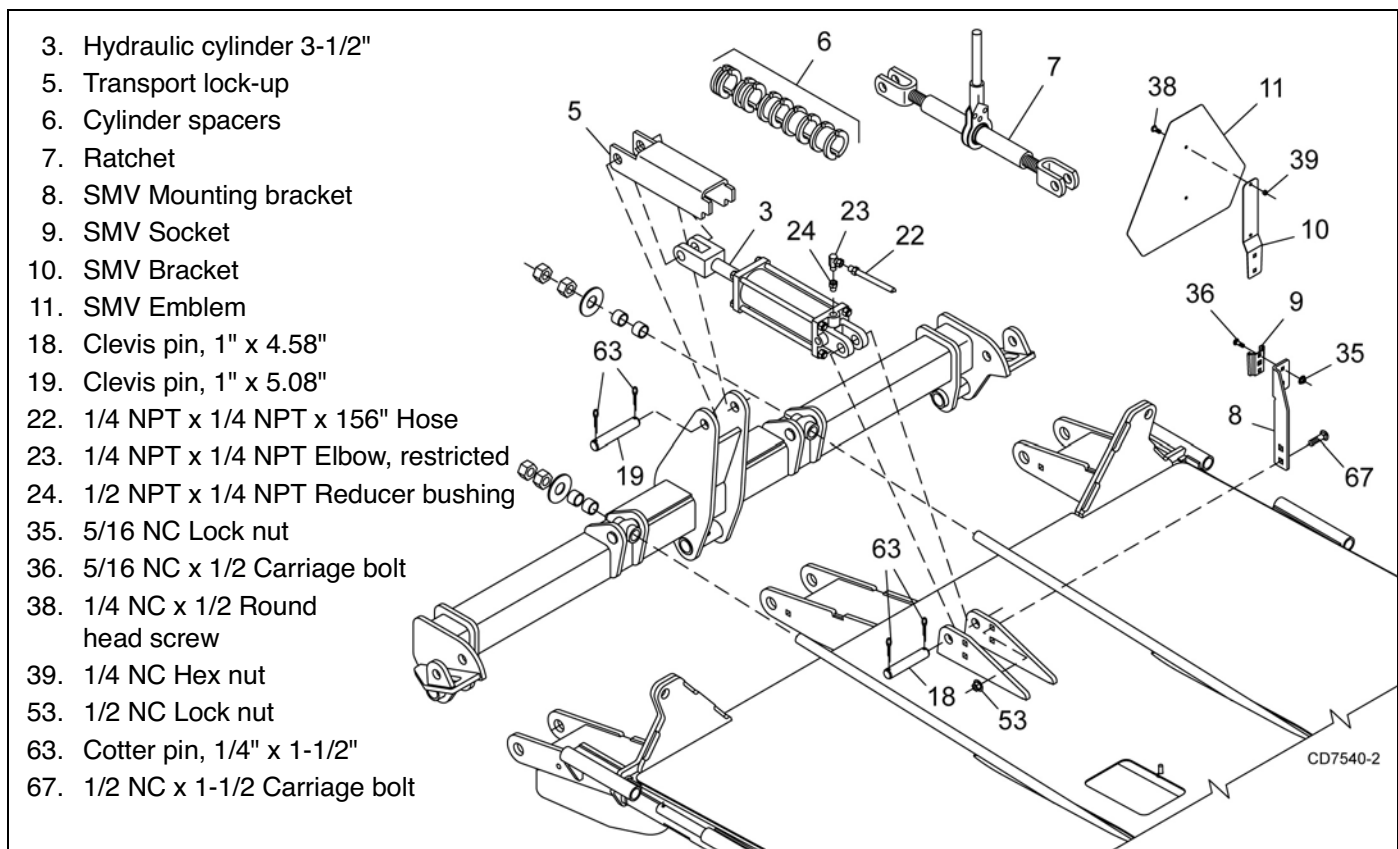

Figure 23. Spring Arm and Cylinder Installation

Install Spring Wheel Arms

1. Slide right spring wheel arm assembly (14) over center wheel yoke tube and secure into position using four cap screw (28) and flanged lock nut (37). Repeat step to install left spring wheel arm assembly. Keep spacing as wide as possible for greater stability.
2. Attach wheels to hubs using five lug nuts. Install the chamfered side of the lug nut toward the inside for steel rim for pneumatic tires and rims. Tighten to 75 lbs-ft. Check that tire air pressure is a maximum of 40 psi.

NOTE: Install the flat side of the nut toward the inside for solid tires and aircraft tires (shown).

NOTE: Pneumatic, notat, and airplane tires are available for this cutter. See page 67 for parts list.

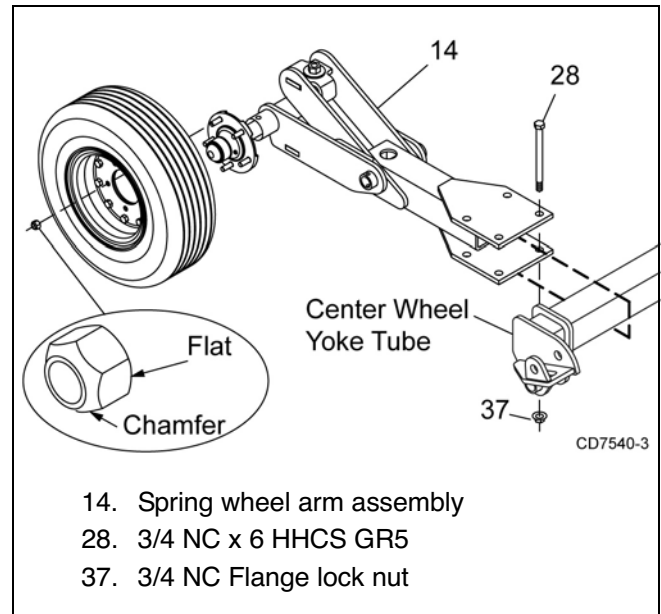

Figure 24. Right Spring Wheel Arm Installation

Install Tongue

1. Attach tongue (28) to the center section using two 1-1/4 pivot pins (4), carriage screws (75), and hex nuts (50).
2. thread hex nut (73) onto tongue level link (26). Raise tongue and insert level link through center pivot casting.

3. Attach each attitude rod (6) between the lugs on tongue and secure with spacer (83), clevis pin (5), carriage screw (75), and lock nut (50).
4. Attach parking jack (29) to the side of the tongue.
5. Attach second hex nut (73) to tongue level link (26) on the back side of center pivot casting.
6. Attach hose holder (31) to the top of the tongue using two cap screws (53) and lock nuts (50).

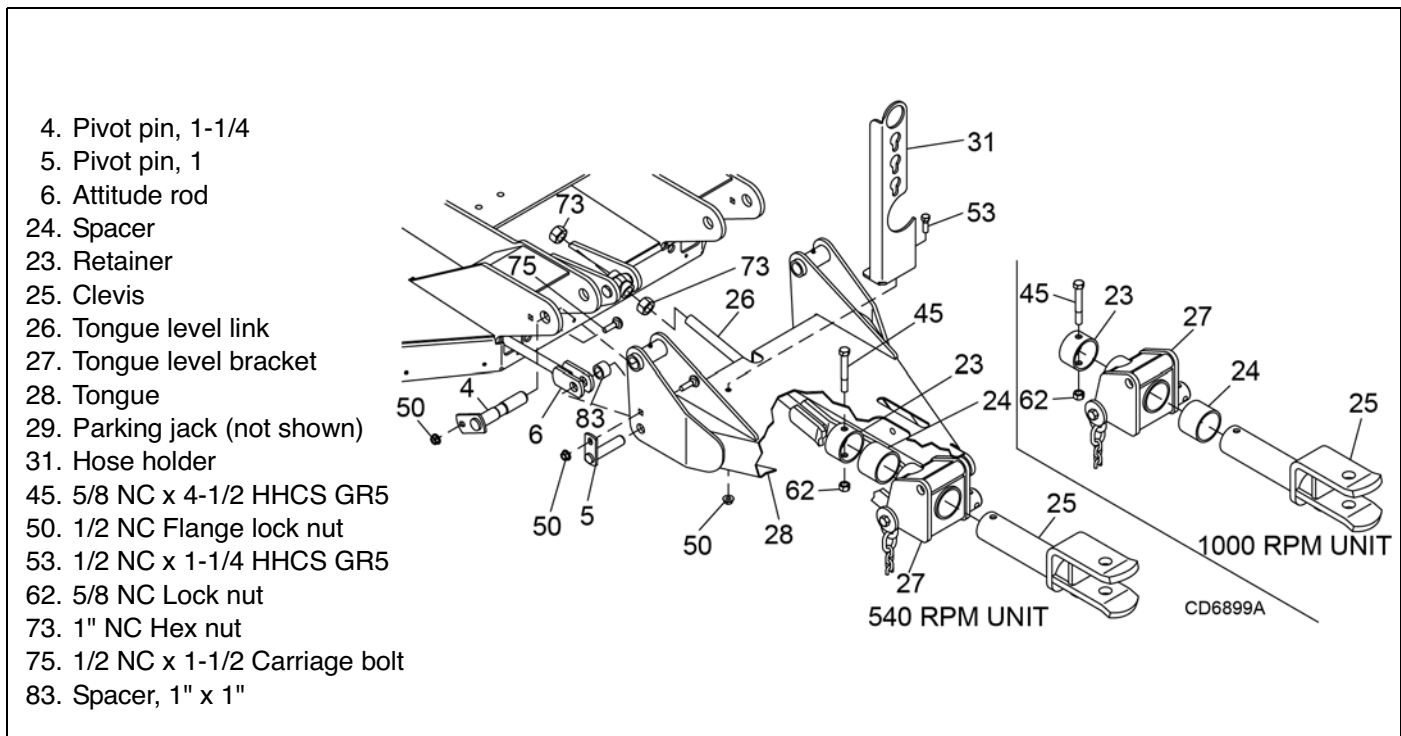

Figure 25. Tongue Installation

Install 3-Joint Drive (540 RPM Only)

Before installing cutter input driveline to gearbox, check the tag wired to the driveline and the tag wired to the input shaft of gearbox. Ensure the tag rpm speeds match the rpm speed decal on front of cutter. After confirming all speeds match, remove and discard tags and then complete driveline assembly.

1. Attach H-frame (30) to tongue with two bolts (77), sleeves (47), cup washers (60), and nuts (62).
2. Coat splined end of gearbox input shaft with grease.
3. Slide drive (33) onto shaft and align hole in drive yoke with groove on gearbox input shaft.
4. Secure with bolt and nut supplied with drive.

5. Secure driveline carrier bearing to H-frame with pin (69) and cotter pin (70).
6. Attach front driveline (32) to rear driveline (33) and tighten clamp bolt and nut supplied with drive.

NOTE: When cutting height is established, adjust the 3-joint H-frame bearing height so that the front driveline is parallel to the ground.

7. Attach shield (19) to driveline carrier bearing with two cap screws (68) and flange lock nuts (50).
8. Attach spacer (71) to the top hole of the H-frame using cap screw (68) and flanged lock nut (50).

NOTE: See Figure 27 for optional CV drive installation.

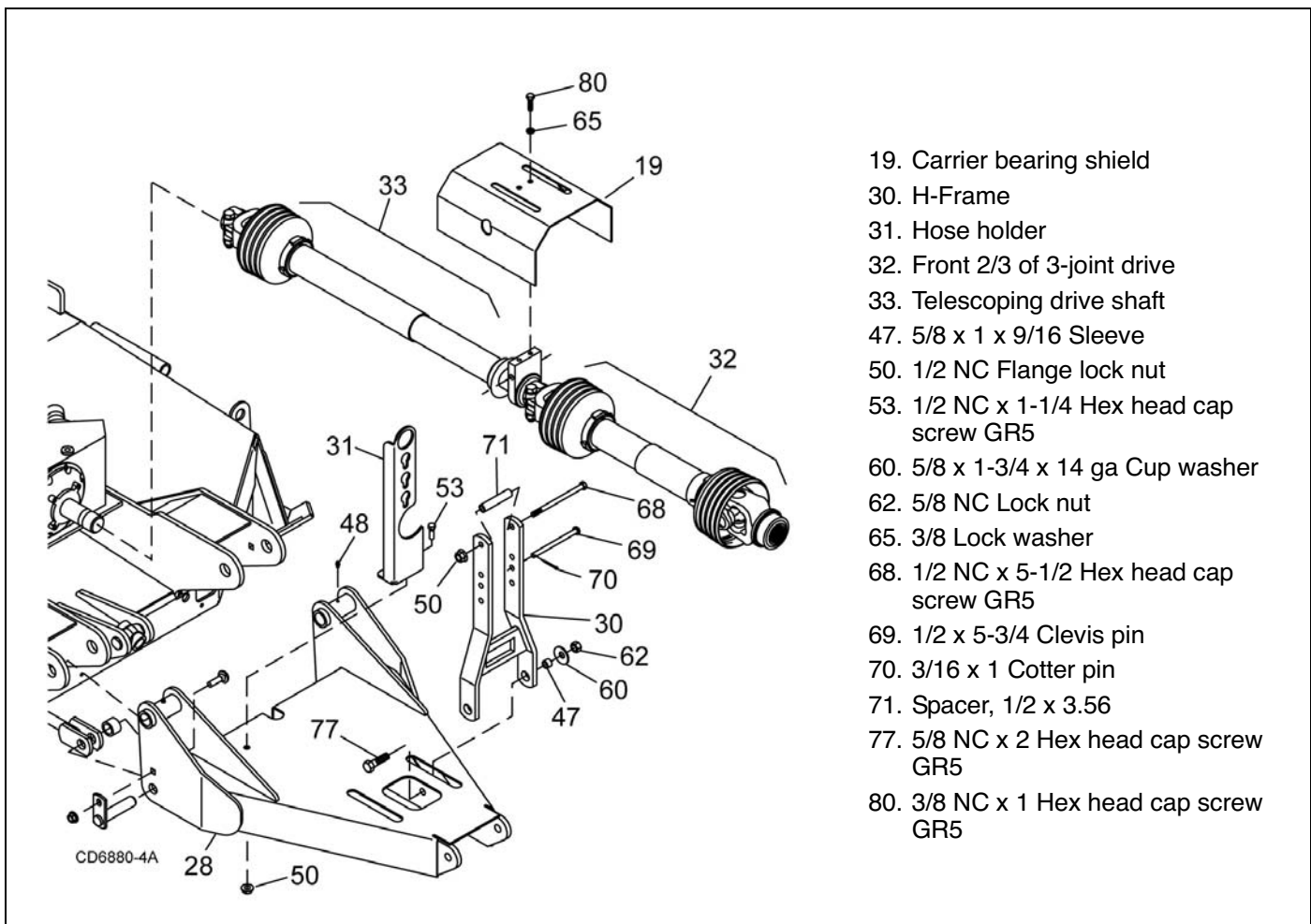

Figure 26. 3-Joint Drive Installation

Install CV Drive (Optional)

Before installing cutter input driveline to gearbox, check the tag wired to the driveline and the tag wired to the input shaft of gearbox. Ensure the tag rpm speeds match the rpm speed decal on front of cutter. After confirming all speeds match, remove and discard tags and then complete driveline assembly.

1. Align hole in drive yoke with groove on gearbox input shaft and slide rear half of drive (23) onto shaft.
2. Secure with bolt and nut supplied with drive.

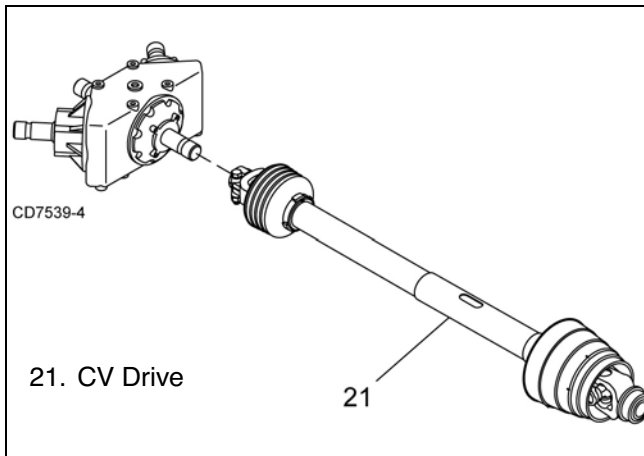

Figure 27. CV Drive Installation

WING ASSEMBLY

Install Wing

CAUTION

■ Use a suitable lifting device of sufficient capacity. Use adequate personnel to handle heavy components.

The wing must be installed in the following sequence and will require at least two people. A floor jack or a suitable lifting device will be helpful to align decks when installing the hinge pin.

1. Remove hinge pin (13) from center section.
2. Place wing assembly adjacent to the center section and align hinge sections.
3. Insert hinge pin through the hinge sections and secure with spring pin (67) and washer (35) on both ends.

4. Repeat procedure of opposite wing.

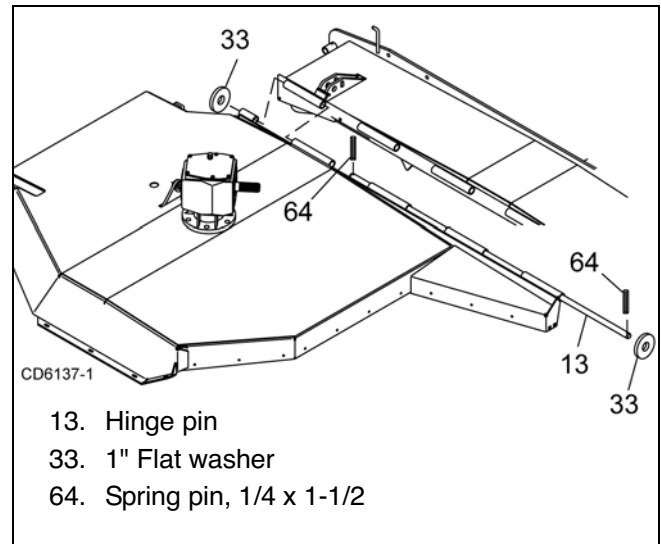

Figure 28. Right Wing Installation (Typical)

Install Wing Cylinder & Transport lock

Refer to Figure 29.

1. Slide rod end of wing cylinder (5) through box end of wing transport lock bracket (20).
2. Place base end of cylinder and wing transport lock bracket over cylinder lug on center section and align holes. Secure to cylinder lug using clevis pin (19) and two cotter pins (63).
3. Remove plug from base end of hydraulic cylinder and rod end of cylinder.
4. Extend cylinder fully and replace plug in base end of cylinder. This trapped air will help push wing down.
5. Align cylinder rod end with slotted holes on wing cylinder lugs and secure using clevis pin (18) and two cotter pins (63).
6. Insert lock-up pin (29) in lower hole and secure using lynch pin (40).
7. Install bushing (24) and elbow (23) to the rod end of cylinder (5). Position elbow to point to the center section.
8. Insert hose (25) through hose guide on transport lock bracket and secure to elbow.
9. Repeat procedure for opposite wing.

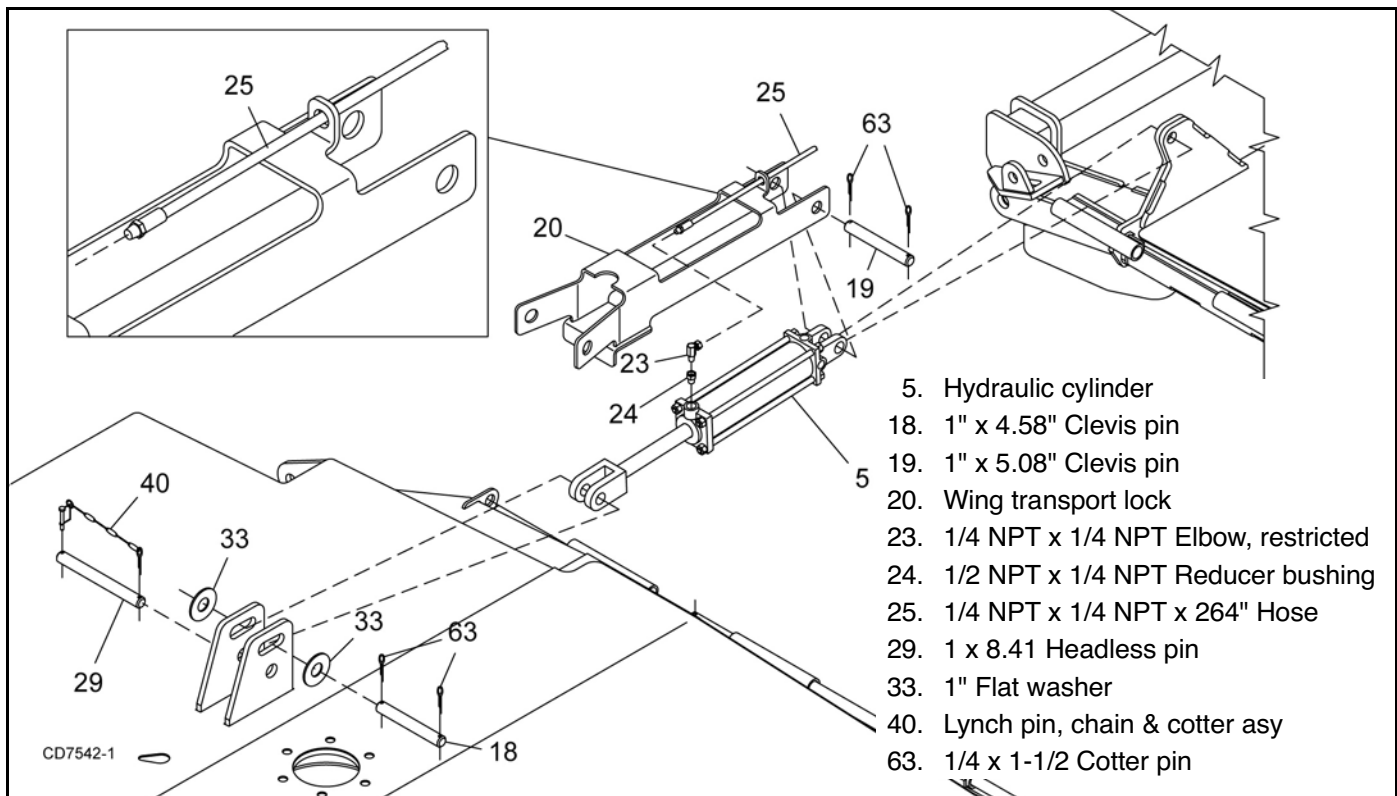

Figure 29. Wing Cylinder & Wing Transport Lock Installation

Install Wing Wheel Yoke

1. Attach wing wheel yoke (6) to the wing using pivot pins (31). Make sure pin flange is on the underside of the deck. See Figure 30.
2. Secure pivot pins to deck using carriage bolts (67) and flange lock nuts (53). Carriage bolts are on the outside, lock nuts on the underside.
3. Insert wheel hub (17) into wing wheel yoke arm (6) and align holes.

4. Secure into position using cap screw (30) and flanged lock nut (53).
5. Attach wheel to hub using five lug nuts. Install the chamfered side of the lug nut toward the inside for steel rim for pneumatic tires and rims. Tighten to 75 lbs-ft. Set tire pressure to a maximum of 40 psi.

NOTE: Install the flat side of the nut toward the inside for solid tires and aircraft tires (shown).

6. Install optional dual wheel and hub to inside of wheel yoke arm.

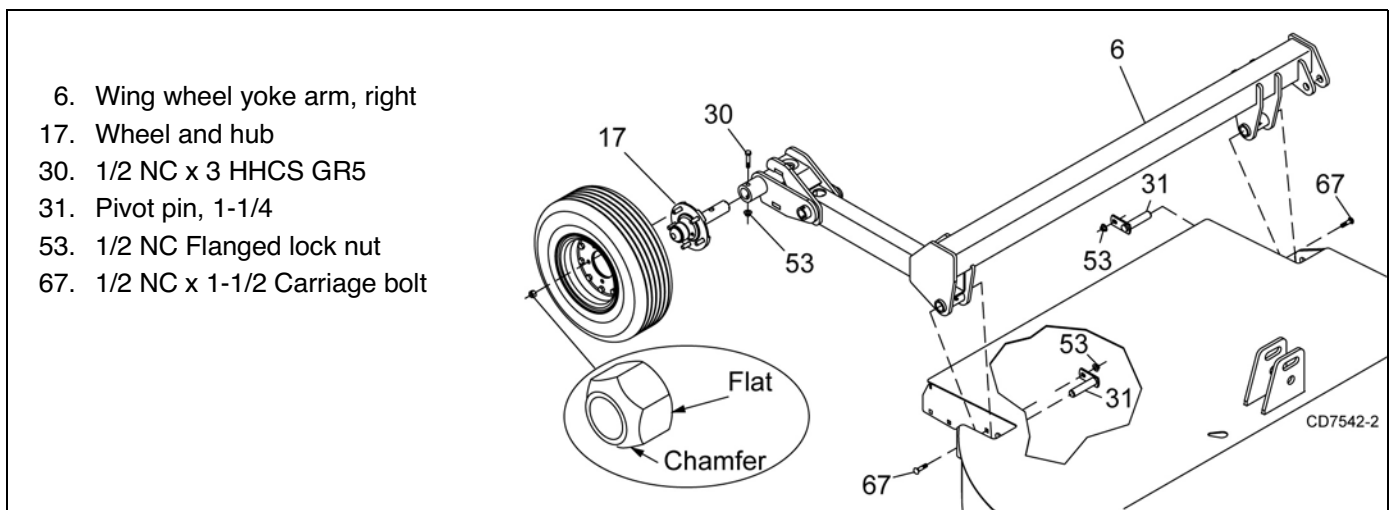

Figure 30. Wing Wheel and Hub Installation - Right

Install Wing Wheel Yoke Adjustment Link

CAUTION

■ Use a suitable lifting device of sufficient capacity. Use adequate personnel to handle heavy components.

1. With a lifting device raise right wing and lock in the up position using the wing lock-up bar. Leave lifting device attached for added support.
2. Attach adjustable link (turnbuckle, 22) to right side of center wheel yoke arm and secure with cap screw (32) and lock nut (26).
3. Attach opposite end of adjustable link (22) to wing wheel yoke arm and secure with cap screw (32) and lock nut (26).
4. Remove lock-up bar and carefully lower wing using lifting device.
5. Repeat process for left wing.
6. See Cutting Height (Normal Mowing) - Wings, page 16 to level wings.

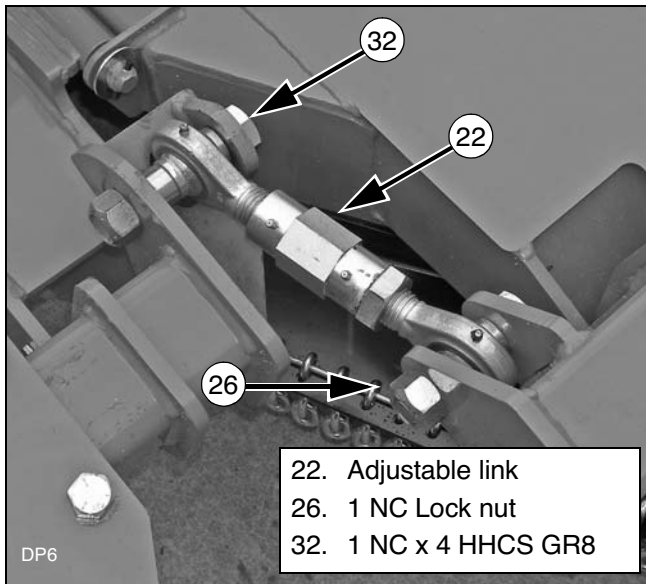

Figure 31. Right Wing Wheel Yoke Adjustment Link Installed

Install Wing Driveline

1. Remove knob on top of clutch shield (3) and raise shield.
2. Slide clutch of driveline (4) over wing gearbox shaft and align holes with groove.
3. Secure driveline to shaft using cap screws and lock nuts supplied with driveline.
4. Slide opposite end of driveline over splitter gearbox and secure using cap screws and lock nuts supplied with driveline.
5. Repeat process for left driveline.

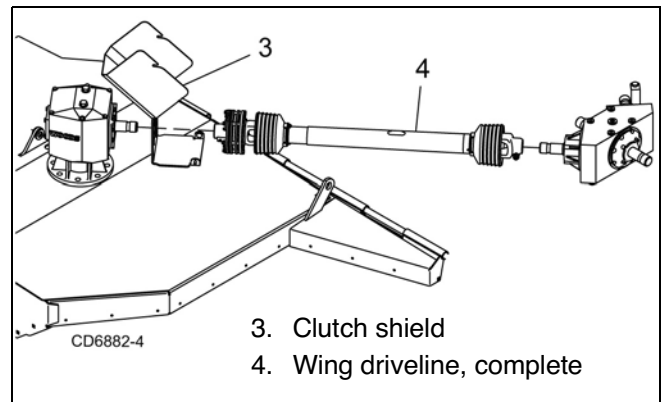

Figure 32. Right Driveline Installation

FILL GEARBOXES

1. Remove top and side plugs from gearbox.
2. Fill gearbox with SAE 80W or 90W EP oil until it runs out of side level hole. Install plug in the side hole and vented dipstick in the top.
3. Allow oil to drain into the lower bearings and recheck oil level.
4. Fill all gearboxes.
5. Attach hose to each elbow.

OPTIONAL EQUIPMENT

Install Tandem Wheel Assembly (Center)

1. Slide spring wheel arm assembly (1) over right side of center wheel yoke tube and secure into position using four cap screw (22) and flanged lock nut (23). Repeat step to install spring wheel arm assembly on left side of center wheel yoke tube.
2. Place tandem wheel bracket (16) around lower lower spring arm (13) and insert flange pin (17). Secure flange pin to tandem wheel bracket using cap screw (18) and flat washer (19).
3. Insert wheel hubs (15) into both sides of tandem wheel bracket (16) and align holes.
4. Secure into position using cap screws (20) and flanged lock nuts (21).
5. Attach wheel to hub using five lug nuts. Install the chamfered side of the lug nut toward the inside for steel rim for pneumatic tires and rims. Tighten to 75 lbs-ft. Check that tire air pressure is a maximum of 40 psi.

NOTE: Install the flat side of the nut toward the inside for solid tires and aircraft tires (shown).

Install Tandem Wheel Assembly (Wing)

1. Attach wing wheel yoke (2) to the wing using pivot pins (31). See Figure 30 for pin and hardware installation. Make sure pin flange is on the underside of the deck.
2. Secure pivot pins to deck using carriage bolts (67) and flange lock nuts (53). See Figure 30 for pin and hardware installation. Carriage bolts are on the outside, lock nuts on the underside.
3. Place tandem wheel bracket (16) around lower lower spring arm (3) and insert flange pin (17). Secure flange pin to tandem wheel bracket using cap screw (18) and flat washer (19).
4. Insert wheel hubs (15) into both sides of tandem wheel bracket (16) and align holes. Secure using cap screws (20) and flanged lock nuts (21).
5. Attach wheel to hub using five lug nuts. Install the chamfered side of the lug nut toward the inside for steel rim for pneumatic tires and rims. Tighten to 75 lbs-ft. Set tire pressure to a maximum of 40 psi.
6. Install the flat side of the nut toward the inside for solid tires and aircraft tires (shown).

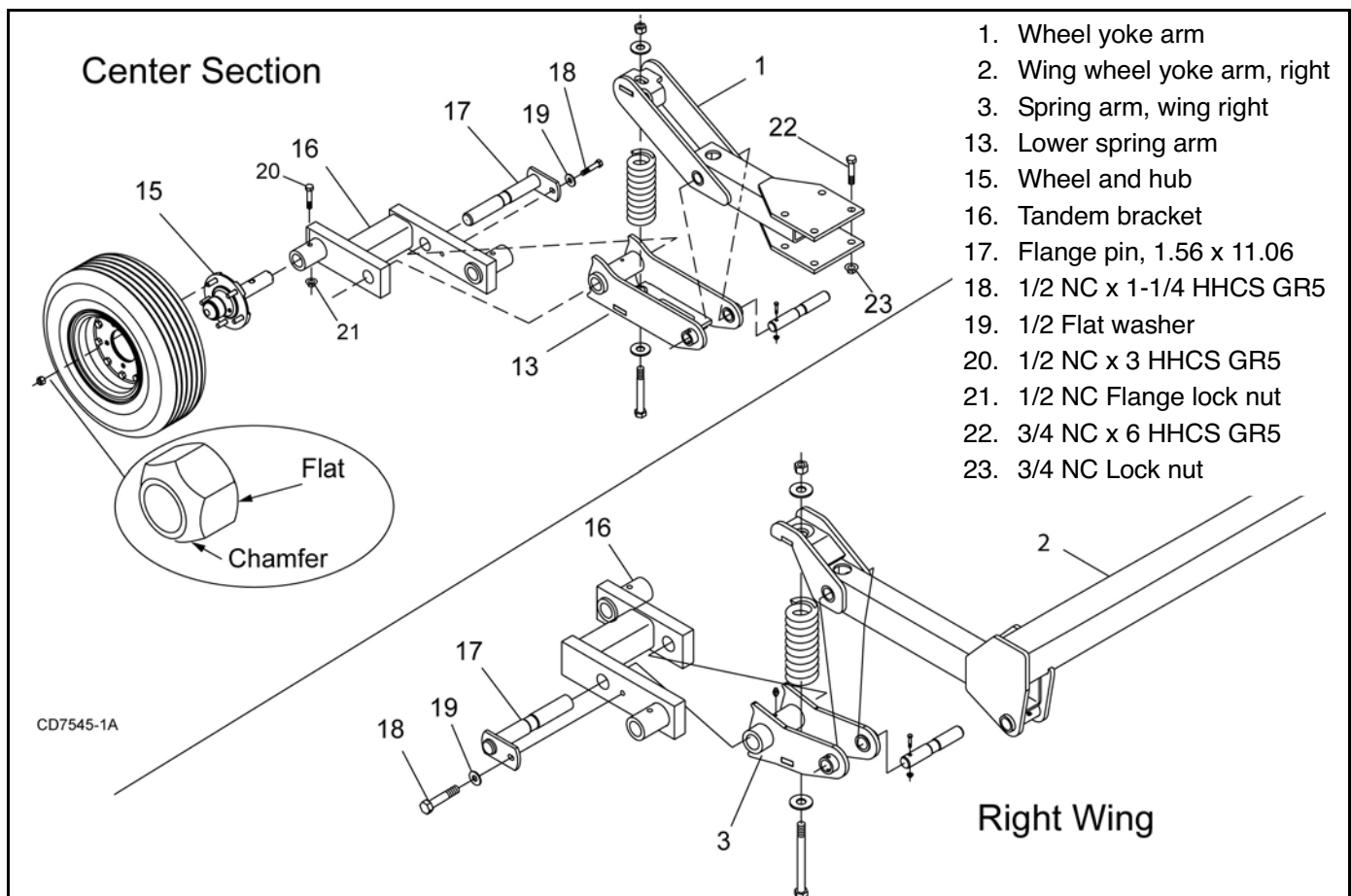

Figure 33. Tandem Wheel Assembly Installation

INSTALL CHAIN OR BELT SHIELDING

DANGER

■ Full chain shielding must be installed when operating in populated areas or other areas where thrown objects could injure people or damage property.

- If this machine is not equipped with full chain shielding, operation must be stopped when anyone comes within 300 feet (92 m).
- This shielding is designed to reduce the risk of thrown objects. The mower deck and protective devices cannot prevent all objects from escaping the blade enclosure in every mowing

condition. It is possible for objects to ricochet and escape, traveling as much as 300 feet (92 m).

Install chain and rubber shields with hardware as shown. (Refer to Figure 34 and Figure 35 for Chain Shielding Installation; Figure 36 and Figure 37 for Belt Shielding Installation.)

NOTE: CHAIN SHIELDING - Center Section: Attach rear chain plates (4) to the top of center section. Attach center chain plate (18) to the bottom of the center section. **Wing:** Install four (two per wing) 6-link chain sections (12) and four (two per wing) 4-link chain sections (13) to the wing skid shoes. Secure with carriage bolts (14) and flange lock nuts (15). See Figure 35.

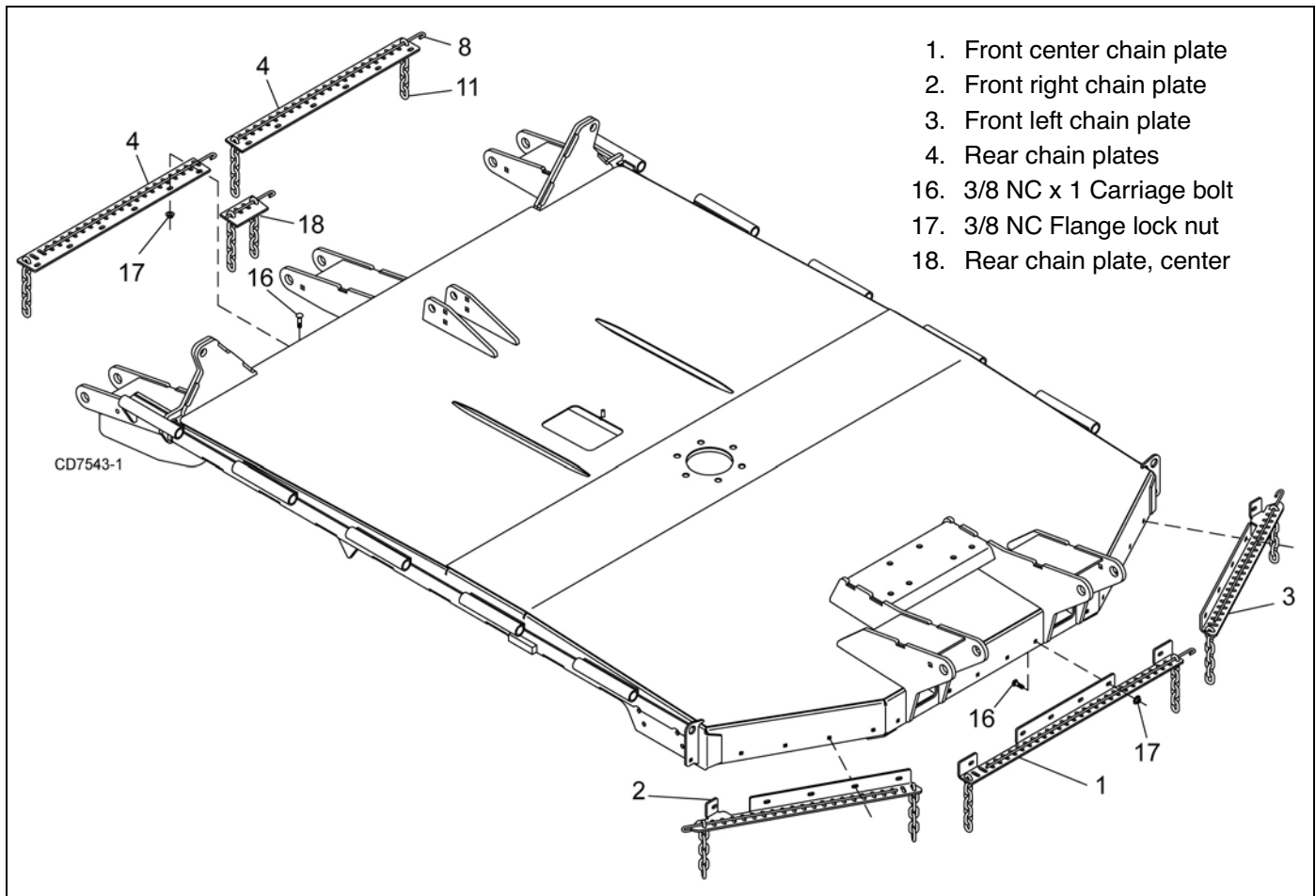

Figure 34. Chain Shielding Installation - Center Section

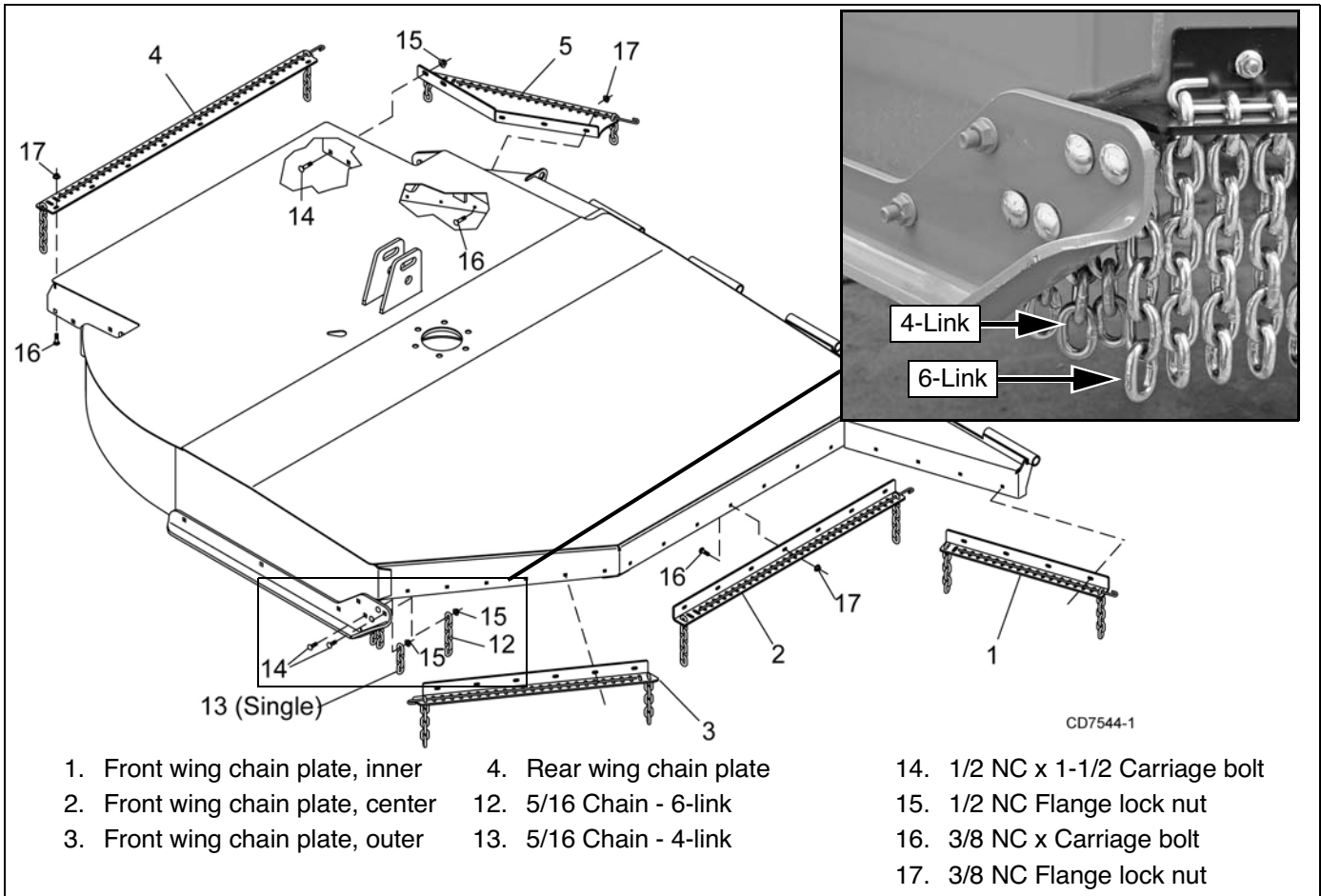

Figure 35. Chain Shielding Installation - Right Wing Shown

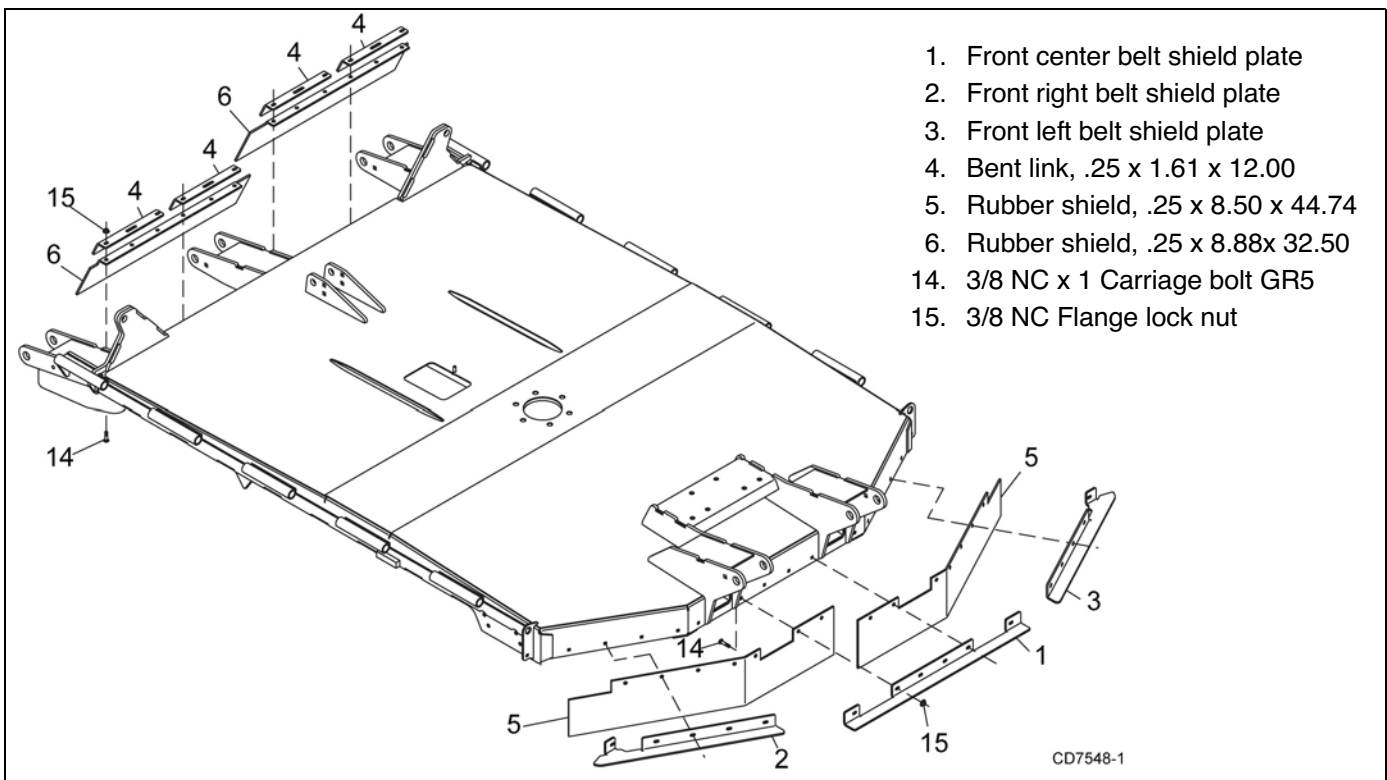

Figure 36. Belt Shielding Installation - Center Section

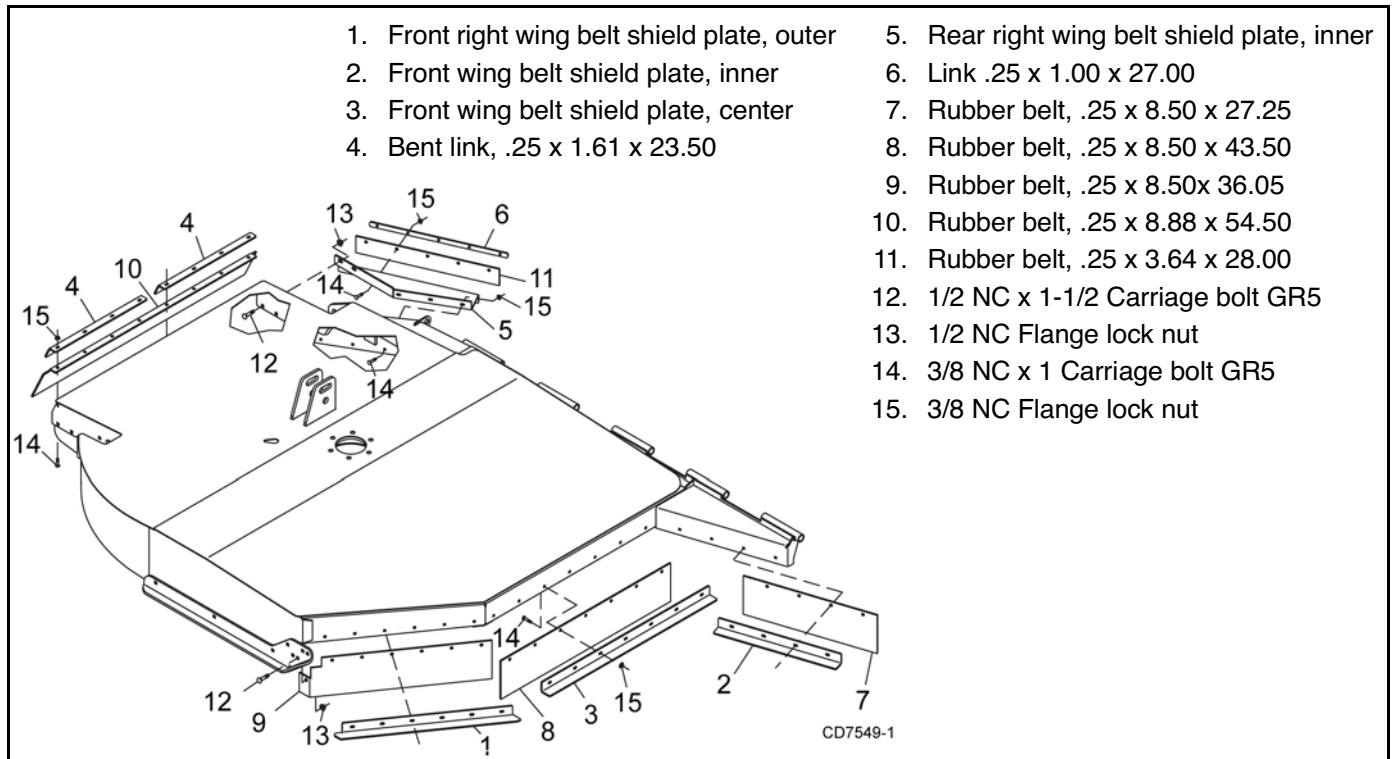

Figure 37. Belt Shielding Installation - Right Wing

Winch Kit Installation

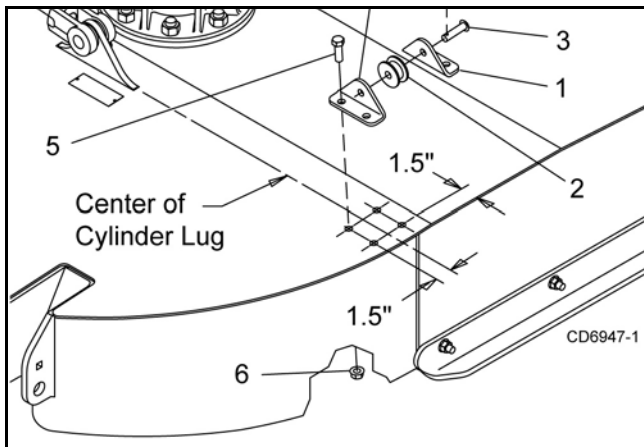

Figure 38. Roller Assembly Installation

1. Locate and drill one 9/16" hole in each wing using dimensions shown in Figure 38. Assemble items 1, 2, 3 and 4. Use assembly to locate and drill remaining holes.
2. Secure idler brackets (1) and rollers (2) to deck with bolts (5) and nuts (6).
3. Remove cylinder pin: Place channel (10) over cylinder and cylinder lug. Place wing lock-up bracket over channel and insert pin (8), washers (7), and cotter pins (9). NOTE: Washers (7) are used as spacers and are placed between lock-up bracket and channel (10) as needed.

4. Repeat step to install second channel (10) on opposite wing.
5. Attach winch assembly to channels (10) using bolts (5) and lock nuts (6).
6. Move SMV sign and hardware to channel as shown in the winch kit instructions.
7. Tighten all hardware. See Parts page 75 for complete diagram and part list.

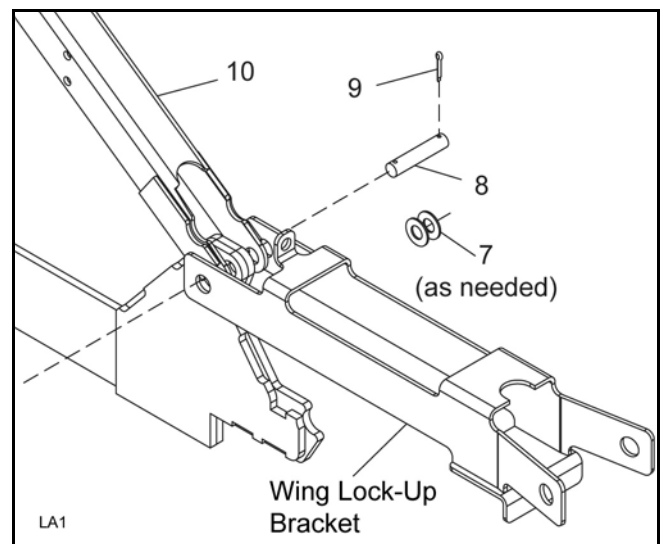

Figure 39. Winch Channel Installation

Shredder Installation (Optional)

Crossbar Installation - Right Wing (Figure 40 & Figure 43)

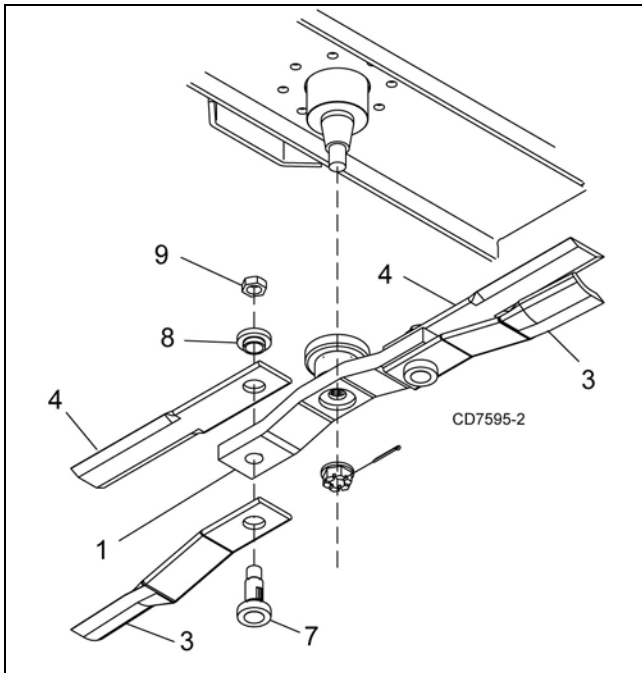

Figure 40. Right Crossbar and Blade Installation

1. Install wing crossbar (1) on splined shaft. Use flanged castle nut and cotter pin previously removed. Torque nut to 450 lbs-ft.
2. Place CCW blade (3) over blade pin (7) and insert blade pin through crossbar. Make sure blade offset is to the bottom.
3. Place blade (4) over blade pin with flat surface on the top.
4. Install bushing (8) over pin and blade and secure with jam nut (9). Torque nut to 664 lbs-ft.

Crossbar Installation - Left Wing

1. Repeat steps for left crossbar and blade installation.
2. Use wing crossbar (1) and offset CW blades (2) and flat blades (4).

Crossbar Installation - Center Section

1. Repeat steps for center crossbar and blade installation.
2. Use crossbar (1) and offset CCW blades (3) and flat blades (4).

Install Stationary Blades - Center Section

1. Remove left skid shoe if needed.

2. Place stationary blade mounting bracket (6) on the backside (outside) of the front left baffle. Mounting bracket leg should point to the outside.
3. Secure mounting bracket into position using four cap screws (12), eight hardened flat washers (14) and flange lock nuts (13).

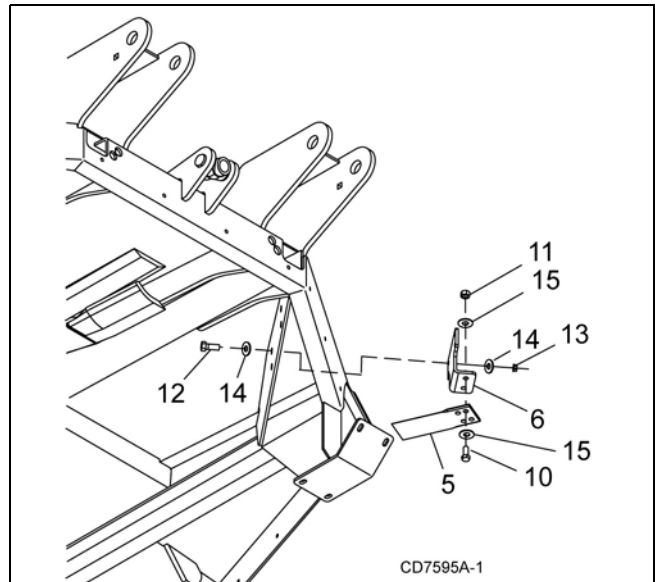

Figure 41. Blade Mounting Bracket Installation - Center Section

4. Attach stationary blade (5) to mounting bracket using two cap screws (10), four hardened flat washers (15) and lock nuts (11).

NOTE: Stationary blade should fit between the two rotating blades on the crossbar.

5. Replace skid shoe using existing hardware if removed.

Install Stationary Blades - Right and Left Wing

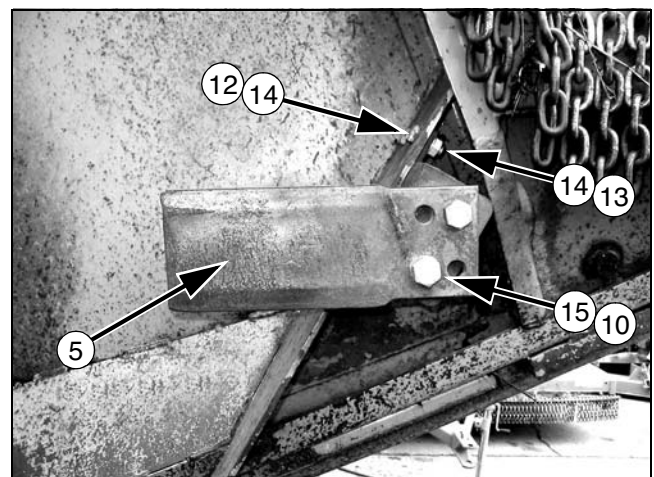

Figure 42. Stationary Blade Installed - Right Wing

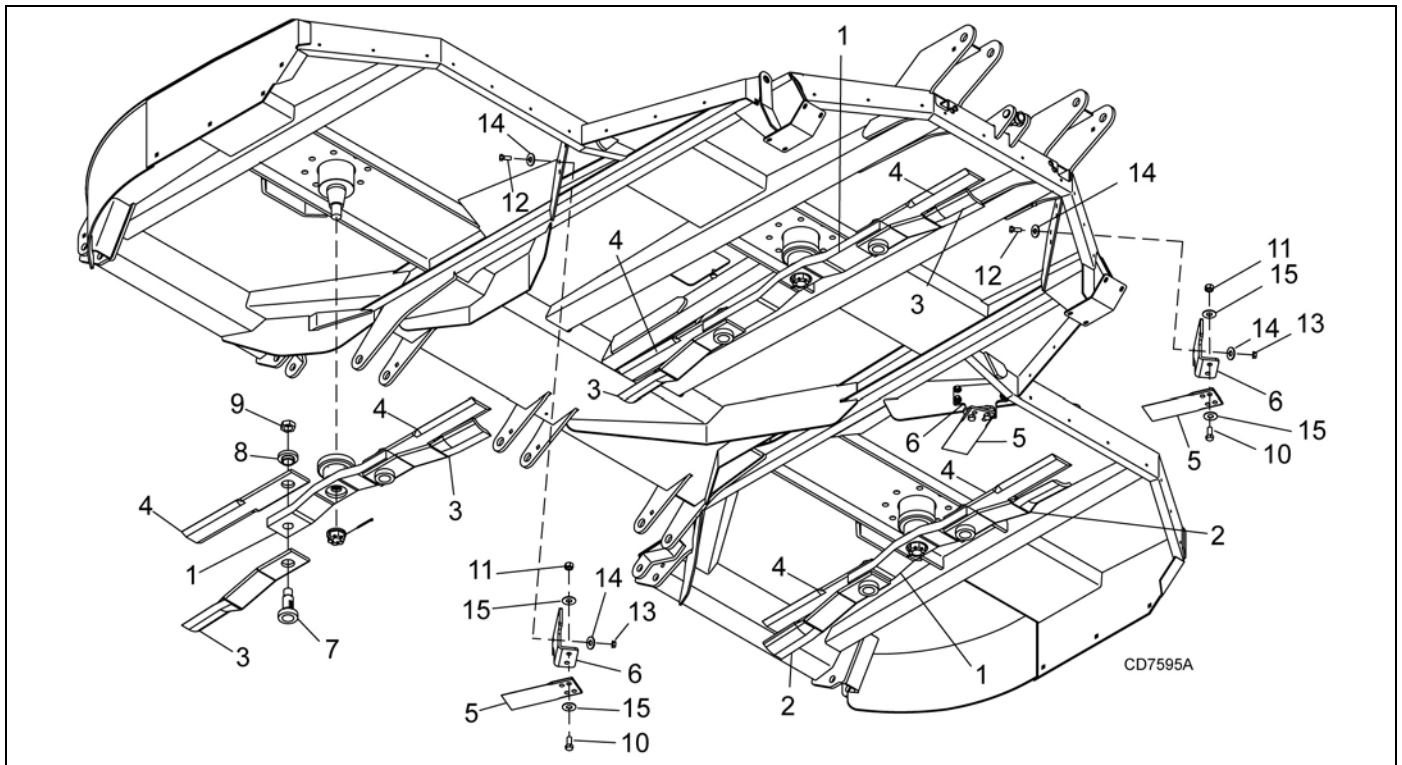

Figure 43. Shredder Kit Installation

1. Attach mounting bracket (6) to the front side of the front baffle and secure with cap screws (12), hardened flat washers (14) and lock nuts (13). Do not tighten hardware.
2. Attach stationary blade (5) to mounting bracket (6) using two cap screws (10), four hardened flat washers (15) and lock nuts (11). Blade should be angled by using the first hole on the left side and the second hole on the right side. Refer to Figure 42.

3. Rotate crossbar and blades so stationary blade fits between the two crossbar blades. Adjust mounting bracket (6) so the stationary blade (5) is 1" below flat blade (4), Tighten all hardware. See Figure 42.

NOTE: Stationary blade should be parallel to the rotating blades, point toward the center of the gear-box and rear of cutter, and overlap rotating blades approximately 4 inches.

4. Repeat steps to install stationary mounting bracket (6) and blade (5) to the opposite wing.

DEALER CHECK LISTS

PRE-DELIVERY CHECK LIST

(DEALER'S RESPONSIBILITY)

Inspect the equipment thoroughly after assembly to ensure it is set up properly before delivering it to the customer.

The following check lists are a reminder of points to inspect. Check off each item as it is found satisfactory or after proper adjustment is made.

NOTICE

■ **Gearboxes are not filled at the factory. Prior to delivery, make sure each gearbox is filled between lowest ring and end of dipstick with 80 or 90W API GL-4 or GL-5 gear lube.**

- ___ Check that all safety decals are installed and in good condition. Replace if damaged.
- ___ Check that shields and guards are properly installed and in good condition. Replace if damaged.
- ___ Check all bolts to be sure they are properly torqued.
- ___ Check wheel bolts for proper torque.
- ___ Check that all cotter pins and safety pins are properly installed. Replace if damaged.
- ___ Check that blades have been properly installed.
- ___ Check and grease all lubrication points as identified in lubrication information on page 21.
- ___ Check the level of gearbox fluids before delivery. Service, if required, as specified in the lubrication information on page 21.

DELIVERY CHECK LIST

(DEALER'S RESPONSIBILITY)

- ___ Show customer how to make adjustments and select proper PTO speed.
- ___ Show customer how to make sure driveline is properly installed and that spring-activated locking pin or collar slides freely and is seated in groove on tractor PTO shaft.
- ___ Show customer how to determine the turning limits of the CV PTO driveline.
- ___ Show customer the safe, proper procedures to be used when mounting, dismounting, and storing equipment.
- ___ Make customer aware of optional equipment available so that customer can make proper choices as required.

- ___ Instruct customer how to lubricate and explain importance of lubrication.
- ___ Point out the safety decals. Explain their meaning and the need to keep them in place and in good condition. Emphasize the increased safety hazards when instructions are not followed.
- ___ Explain to customer that when transporting the cutter, the wing and center sections should be raised and their respective transport bars installed and pinned in place.
- ___ Present Operator's Manual and request that customer and all operators read it before operating equipment. Point out the manual safety rules, explain their meanings and emphasize the increased safety hazards that exist when safety rules are not followed.
- ___ Explain to customer the potential crushing hazards of going underneath raised equipment. Instruct that before going underneath to disconnect the driveline, securely block up all corners with jack stands and to follow all instructions in the BLOCKING METHOD, page 20 of the operator's manual. Explain that blocking up prevents equipment dropping from hydraulic leak down, hydraulic system failures or mechanical component failures.
- ___ Point out all guards and shields. Explain their importance and the safety hazards that exist when not kept in place and in good condition.
- ___ Explain to customer that when towing on a public road to comply with all state and local lighting/marketing laws and to use a safety tow chain.

NOTES

BATWING® Rotary Cutter **BW240HD, BW240HDQ**

MAIN FRAME ASSEMBLY	(FRONT SECTION)	50-51
	(REAR SECTION)	52-53
WING ASSEMBLY		54-55
GEARBOX ASSEMBLY	WING & CENTER	56-57
	SPLITTER	58
DRIVE ASSEMBLY	CENTER DECK	59
	FRONT - 3-JOINT (EQUAL ANGLE)	60
	REAR - 3-JOINT (EQUAL ANGLE).....	61
	540 RPM CV DRIVE	62 - 63
	1000 RPM CV DRIVE	64 - 65
	WING	66
WHEEL & TIRE ASSEMBLY	5-BOLT	67
SHIELDING	RUBBER SHIELDING - CENTER SECTION	68
	RUBBER SHIELDING - WING	69
	CHAIN SHIELDING - CENTER SECTION (OPTIONAL).....	70
	CHAIN SHIELDING - WING (OPTIONAL).....	71
TANDEM AXLE WHEEL YOKE (OPTIONAL)		72
HYDRAULIC CYLINDERS		73
HYDRAULIC CYLINDER STROKE CONTROL KIT		74
CROSSBAR PULLER (OPTIONAL)		74
WINCH KIT (OPTIONAL).....		75
BW240HD SHREDDER KIT (OPTIONAL).....		76

MAIN FRAME ASSEMBLY (FRONT SECTION)

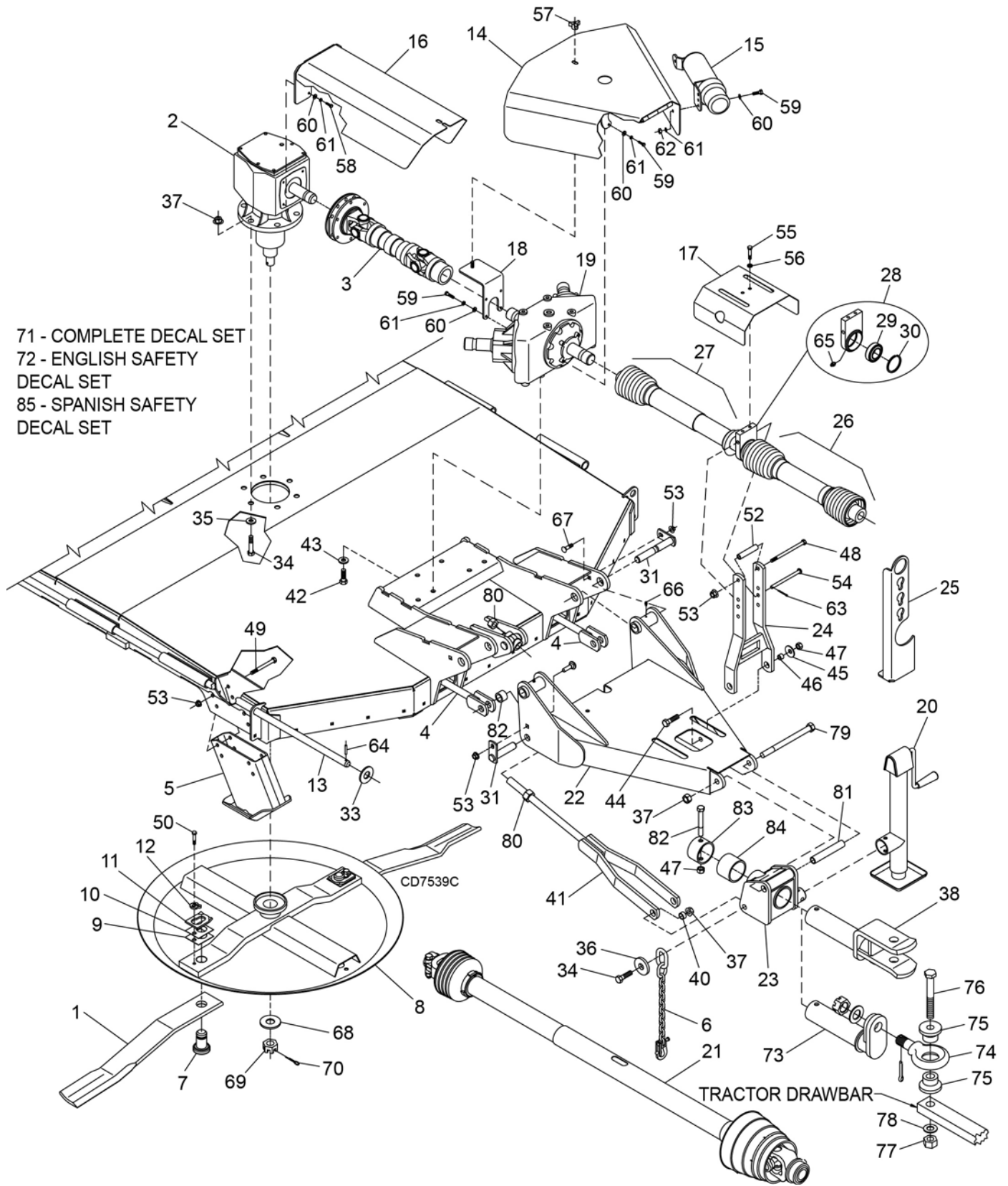

71 - COMPLETE DECAL SET
 72 - ENGLISH SAFETY
 DECAL SET
 85 - SPANISH SAFETY
 DECAL SET

50 Parts

(Rev. 9/11/2013)
 MAN0763 (10/10/2008)

MAIN FRAME ASSEMBLY (FRONT SECTION)

REF	PART	QTY	DESCRIPTION	REF	PART	QTY	DESCRIPTION
1	8825KT	1	Blade kit, CCW	45	10635		5/8 x 1-3/4 x 14 GA Cup washer
2	-----	1	Gearbox (see page 56)	46	1791		.625 x 1 x .563 HT Sleeve
3	1027297	1	Driveline complete, 1340, 1.75-20 12.6	47	6239	*	5/8 NC Hex lock nut
4	1027125	2	Attitude rod	48	12305	*	1/2 NC x 5-1/2 HHCS GR5
5	1027035	2	Front skid	49	3508	*	1/2 NC x 4-1/2 HHCS GR5
6	19407	1	Safety chain	50	6100	*	1/2 NC x 1-1/4 HHCS GR5
7	1008190	2	1-1/2 Blade pin kit (includes 11 & 12)	51	3598	*	1/2 Flat washer
8	1029895	1	Crossbar assembly	52	7035	1	Pipe, 1/2 Schedule 40 x 3.56
9	10520	2	Shim, 18 GA, 1-1/2 blade pin	53	11900	*	1/2 NC Flange lock nut
10	13946	2	Shim, 20 GA, 1-1/2 blade pin	54	404		1/2 x 5-3/4 Clevis pin, HT
11	32603	2	Keyhole plate - special	55	839	*	3/8 NC x 1 HHCS GR5
12	32604	2	Blade pin lock clip - special	56	838	*	3/8 Lock washer
13	1027123	2	Hinge pin	57	66840		3/8 NC 3-Prong knob
14	1027110	1	Front shield with hinge	58	24801	*	M8 x 1.25P x 20 mm HHCS
15	1003828	1	Manual tube	59	14562	*	5/16 NC x 1 HHCS GR5
16	1027115	1	Rear shield with hinge	60	35155	*	5/16 SAE Flat washer
17	1011760	1	Front drive shield	61	2472	*	5/16 Lock washer
18	1027113	1	Shield standoff	62	4529	*	5/16 Hex nut
19	-----	1	Splitter gearbox (see page 58)	63	1256	*	3/16 x 1 Cotter pin
20	52232	1	Parking jack	64	66016	*	Spring pin, 1/4 x 1-1/2
21	1021103	1	CV drive - 540 RPM (see page 62) -or-	65	2985	*	1/4-28 x 90° Grease fitting
21	1021104	1	CV drive - 1000 RPM (see page 64)	66	12296	*	1/4-28 Grease fitting
22	1017210	1	Tongue assembly	67	10284	*	1/2 NC x 2 Carriage bolt GR5
23	1017220	1	Tongue level hitch	69	57308		M36 x 3.0P Castle nut
24	51618	1	H-Frame	70	6185	*	1/4 x 2-1/4 Cotter pin
25	52442	2	Hydraulic hose holder	71	1029899		Complete decal set
26	57282	1	Front 2/3 of 3-joint drive - 540 RPM (see page 60)	72	1003679		English safety decal set
27	1004932	1	Telescoping shaft (see page 61)	73	1017250	1	Pintle Hitch (Optional)
28	32347	1	3-Joint bearing housing (includes 29, 30, 65)	74	11267	1	Pintle Ring ((Includes Washer, Nut & Cotter Pin)
29	13133	1	1-1/2 ID Ball bearing	75	1016969	2	Pintle Bushing
30	12128	1	.062 x 72 mm ID Snap ring	76	15278		1 NC x 7-1/2 HHCS GR5
31	1017055	2	Pivot pin 1-1/4	77	34279	*	1NC Lock Nut
32	46605	2	Clevis pin, 1 x 2.26	78	1863	*	1" SAE Flat washer
33	1863	*	1" Flat washer	79	39160	*	3/4 NC x 8 HHCS
34	30068	*	3/4 NC x 2-1/2 HHCS GR5	80	34279	2	1" NC Hex lock nut
35	57798		3/4 Hardened flat washer	81	1017232	1	Sleeve, .76 x 1 x 6.06 HT
36	8424		3/4 x 2 x 3/8 Flat washer	82	3097	*	5/8 NC x 4-1/2 HHCS GR5
37	2371	*	3/4 NC Lock nut	83	1017217	1	Spacer sleeve, 3.06 x 3.50 x 1.25
38	1017240	1	Clevis	84	1017218	1	Retainer sleeve
39	28873		3/4 ID x 1-1/2 OD 1/4 Thick washer	85	1036791		Spanish safety decal set
40	13087		3/4 x 1 x 9/16 HT Sleeve				
41	1017230	1	Tongue lever link		HHCS		Hex Head Cap Screw
42	300451	*	5/8 NC x 1-1/4 HHCS GR5		*		Standard hardware, obtain locally
43	57817		5/8 SAE Hardened flat washer				
44	902	*	5/8 NC x 2 HHCS GR5				

MAIN FRAME ASSEMBLY (REAR SECTION)

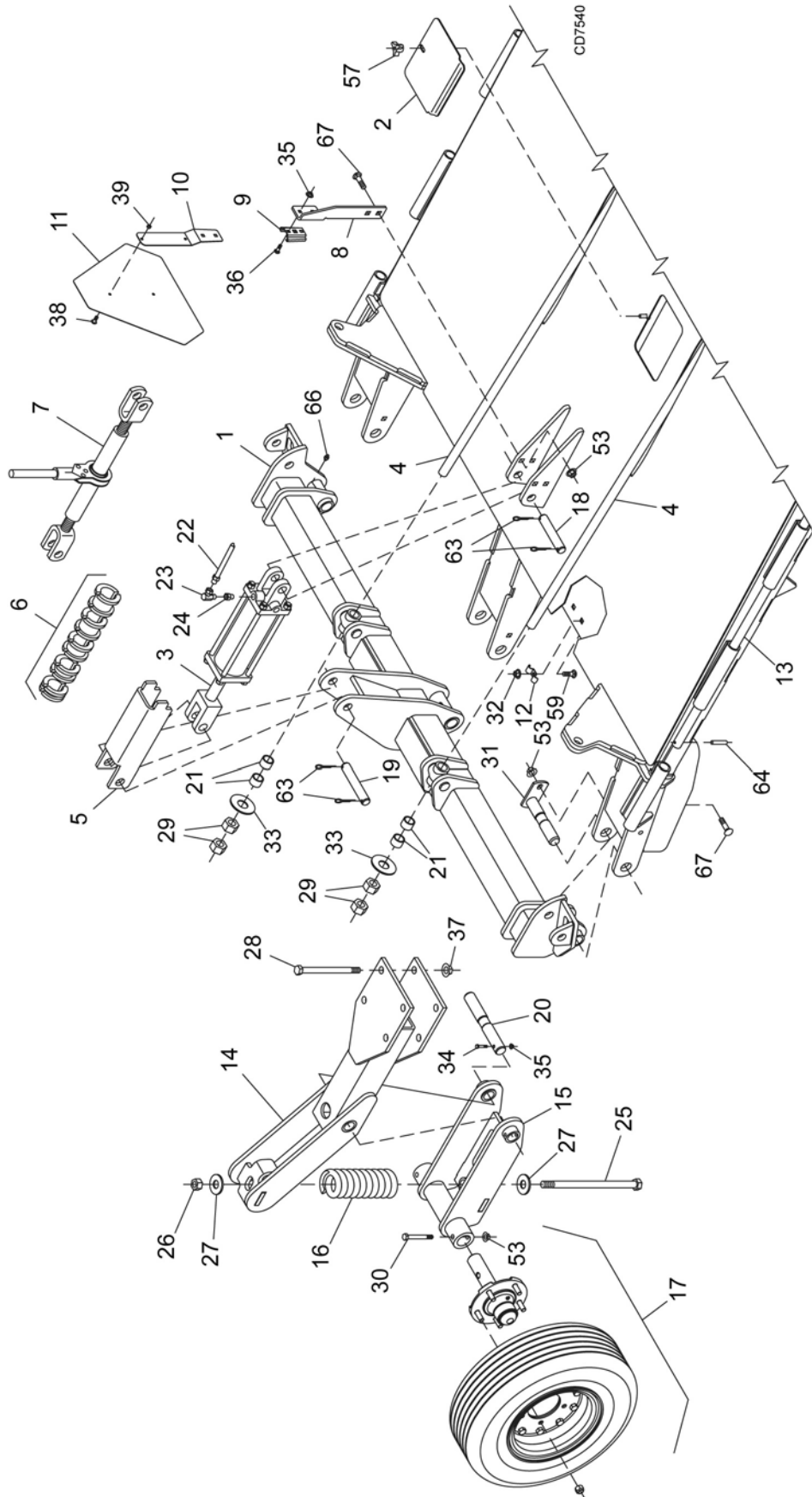

52 Parts

MAIN FRAME ASSEMBLY (REAR SECTION)

REF	PART	QTY	DESCRIPTION	REF	PART	QTY	DESCRIPTION
1	1027070	1	Center wheel yoke	24	11893	1	1/2 x 1/4 Pipe reducer bushing
2	57050	1	Access hole cover	25	1024122	1	NC x 13 HHCS GR5
3	10475	1	Hydraulic cylinder 3-1/2 (see page 73)	26	34279	*	1 NC Lock nut
4	1027125	2	Attitude rod	27	11920	1	x 1-7/8 x 1/4 Washer
5	1004814	1	Transport lock-up	28	2377	3/4	NC x 6 HHCS GR5
6	24098	1	1-1/4 Cylinder stroke control kit (optional)	29	3132	*	1 NC Hex nut
7	23650	1	Ratchet adjustable link bundle (optional)	30	3489	*	1/2 NC x 3 HHCS GR5
8	1017143	1	SMV Mounting link	31	1017055	3	Pivot pin, 1-1/4
9	62484	1	SMV Socket	32	6778	*	5/16 NC lock nut
10	1004251	1	SMV Bracket	33	1863	*	1" Flat washer
11	24611	1	SMV Emblem	34	10509	*	5/16 NC x 2-1/2 HHCS GR5
12	258	1	Feedline clamp - 1/2	35	14139	*	5/16 NC Flange lock nut
13	1027123	2	Hinge pin	36	62532	*	5/16 NC x 1/2 Carriage bolt
14	1024109	2	Spring wheel arm	37	2371	*	3/4 NC Lock nut
15	1017266	2	Lower spring arm	38	1282	*	1/4 NC x 1/2 Round head screw
16	19710	2	Compression spring 3.25 x .69 x 9.5	39	5288	*	1/4 NC Hex nut
17	-----	4	Tire & hub (see page 67)	53	11900	*	1/2 NC Flange lock nut
18	8346	1	1 x 4.58 Headless pin	57	66840		3/8 NC 3-Prong knob
19	8347	1	1 x 5.08 Headless pin	59	14562	*	5/16 NC x 1 HHCS GR5
20	1017149	2	1.25 x 8.85 Pivot pin	63	1285	*	1/4 x 1-1/2 Cotter pin
21	65130	4	Spacer, 1"	64	66016	*	Spring pin, 1/4 x 1-1/2
22	11817	1	1/4 x 1/4 x 230 Hose	66	12296	*	1/4-28 Grease fitting
23	10290	1	1/4 x 1/4 Elbow w/ 1/16 restricter	67	29893	*	1/2 NC x 1-1/2 Carriage bolt GR5
				HHCS			Hex Head Cap Screw
				*			Standard hardware, obtain locally

WING ASSEMBLY

REF	PART	QTY	DESCRIPTION	REF	PART	QTY	DESCRIPTION
1	8825KT	1	Blade kit, CCW (Right wing) - or -	26	34279	*	1 NC Lock nut
1	8820KT	1	Blade kit, CW (Left wing)	27	11920		1 x 1-7/8 x 1/4 Washer
2	-----	1	Gearbox (see page 56)	28	15087		1 NC x 9 HHCS GR5
3	1027120	1	Clutch shield with hinge	29	52329	1	1 x 8.41 Headless pin
4	1027296	1	Driveline complete 2400, 63.4 x 83.7	30	3489	*	1/2 NC x 3 HHCS GR5
5	52234	1	Hydraulic cylinder 3-1/2 x 16	31	1017055	2	Pivot pin, 1-1/4
6	1027080	1	Wing wheel yoke (Right wing) - or -	32	21594		1 NC x 4 HHCS GR8
6	1027081	1	Wing wheel yoke (Left wing)	33	1863	*	1" Flat washer
7	1008190	2	1-1/2 Blade pin kit (includes 11 & 12)	34	10509	*	5/16 NC x 2-1/2 HHCS GR5
8	1029895	1	Crossbar assembly	35	14139	*	5/16 NC Flange lock nut
9	10520	2	Shim, 18 GA, 1-1/2 blade pin	36	34278		1 NC x 5 HHCS GR5
10	13946	2	Shim, 20 GA, 1-1/2 blade pin	37	2371	*	3/4 NC Lock nut
11	32603	2	Keyhole plate - special	38	30068	*	3/4 NC x 2-1/2 HHCS GR5
12	32604	2	Blade pin lock clip - special	39	57798		3/4 Hardened flat washer
13	1027123	1	Hinge pin	40	52204		Lynch pin, chain and cotter assembly
14	1027160	1	Lower spring arm	41	52087		Pivot pin, 1.25 x 7.56
15	1032100	1	Spring, cmp 3.25x.56x7.3x1113	42	1027098		Right skid
16	1027246	1	Deflector plate (Right wing) - or -	43	1027099		Left skid (not shown)
16	1027247	1	Deflector plate (Left wing)	50	6100	*	1/2 NC x 1-1/4 HHCS GR5
17	-----	1	Tire & hub (see page 67)	53	11900	*	1/2 NC Flange lock nut
18	8346	1	1 x 4.58 Headless pin	57	66840		3/8 NC 3-Prong knob
19	8347	1	1 x 5.08 Headless pin	58	24801	*	M8 x 1.25P x 20 mm HHCS
20	1027127	1	Wing transport lock	60	35155	*	5/16 SAE Flat washer
21	65130	1	Spacer, 1"	61	2472	*	5/16 Lock washer
22	1003690	1	Adjustable link	63	1285	*	1/4 x 1-1/2 Cotter pin
23	10290	1	1/4 x 1/4 Elbow w/ 1/16 restricter	64	66016	*	Spring pin, 1/4 x 1-1/2
24	11893	1	1/2 x 1/4 Pipe reducer bushing	66	12296	*	1/4-28 Grease fitting
25	52201	1	1/4 x 1/4 x 264 Hose	67	29893	*	1/2 NC x 1-1/2 Carriage bolt GR5
				69	57308		M36 x 3.0P Castle nut
				70	6185	*	1/4 x 2-1/4 Cotter pin

HHCS Hex Head Cap Screw
 * Standard hardware, obtain locally

WING & CENTER GEARBOX ASSEMBLY

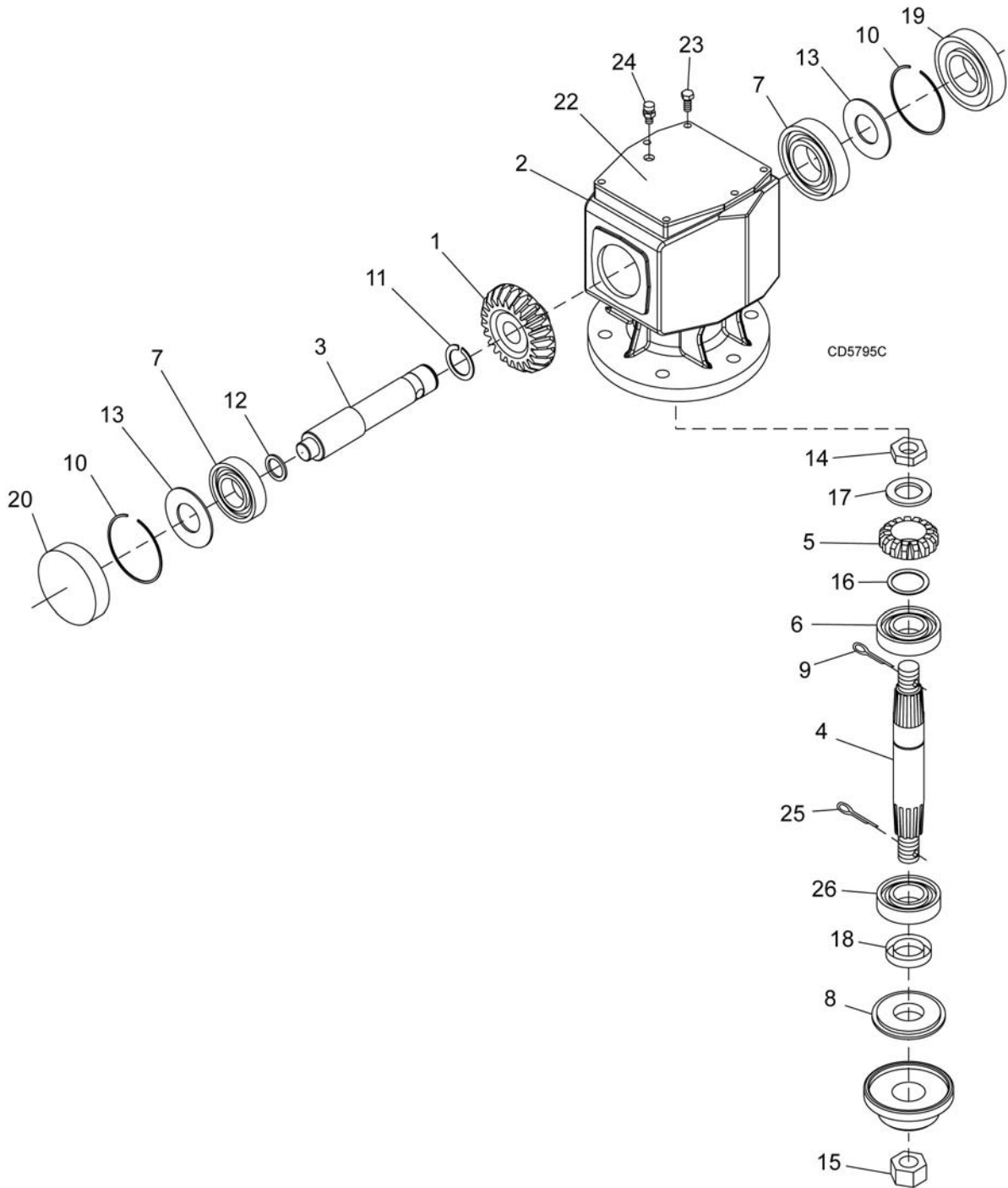

CD5795C

56 Parts

MAN0763 (10/10/2008)

WING & CENTER GEARBOX ASSEMBLY

REF	QTY	540 RPM			1000 RPM			DESCRIPTION
		Left Wing	Center	Right Wing	Left Wing	Center	Right Wing	
A	1	1024795	58808	1029848	1024795	58809	1029848	Complete gearbox
1	1	1025617	57446	1025617	1025617	57447	1025617	Gear crown
2	1	NS	NS	NS	NS	NS	NS	Gearbox housing
3	1	57450	57450	57450	57450	57450	57450	Input shaft
4	1	57454	57454	57454	57454	57454	57454	Output shaft
5	1	1025617	57447	1025617	1025617	57446	1025617	Gear pinion
6	2	39263	39263	39263	39263	39263	39263	Bearing cup & cone
7	2	39411	39411	39411	39411	39411	39411	Bearing cup & cone
8	1	57451	57451	57451	57451	57451	57451	Protective seal
9	1	*	*	*	*	*	*	Cotter pin 3/16 x 2
10	2	57320	57320	57320	57320	57320	57320	Snap ring 85 UNI7437
11	1	57321	57321	57321	57321	57321	57321	Snap ring 50 UNI7435
12	1	57456	57456	57456	57456	57456	57456	Shim 45.3 x 2.5
13	2	57471	57471	57471	57471	57471	57471	Shim 70.3 x 84.7
14	1	57329	57329	57329	57329	57329	57329	Castle nut M40 x 1.5P
15	1	57308	57308	57308	57308	57308	57308	Castle nut M36 x 3.0P
16	1	57471	57471	57471	57471	57471	57471	Shim 50.3 x 70.3
17	1	57471	57471	57471	57471	57471	57471	Shim 40.3 x 61.7 x 1
18	1	57452	57452	57452	57452	57452	57452	Oil seal 60 x 110 x 10
19	1	57318	57318	57318	57318	57318	57318	Oil seal 45 x 85 x 10
20	1	57371	57371	57371	57371	57371	57371	Cap
22	1	57457	57457	57457	57457	57457	57457	Top cover
23	6	*	*	*	*	*	*	M10 x 14 GR8.8 HHCS
24	1	57312	57312	57312	57312	57312	57312	Dipstick, 1/2 x 6.18
25	1	*	*	*	*	*	*	Cotter pin 1/4 x 2-1/4
26	1	57453	57453	57453	57453	57453	57453	Bearing cup & cone

** Crown gear placed on opposite end of input shaft

* Standard hardware, obtain locally

NS Not Serviced

SPLITTER GEARBOX ASSEMBLY

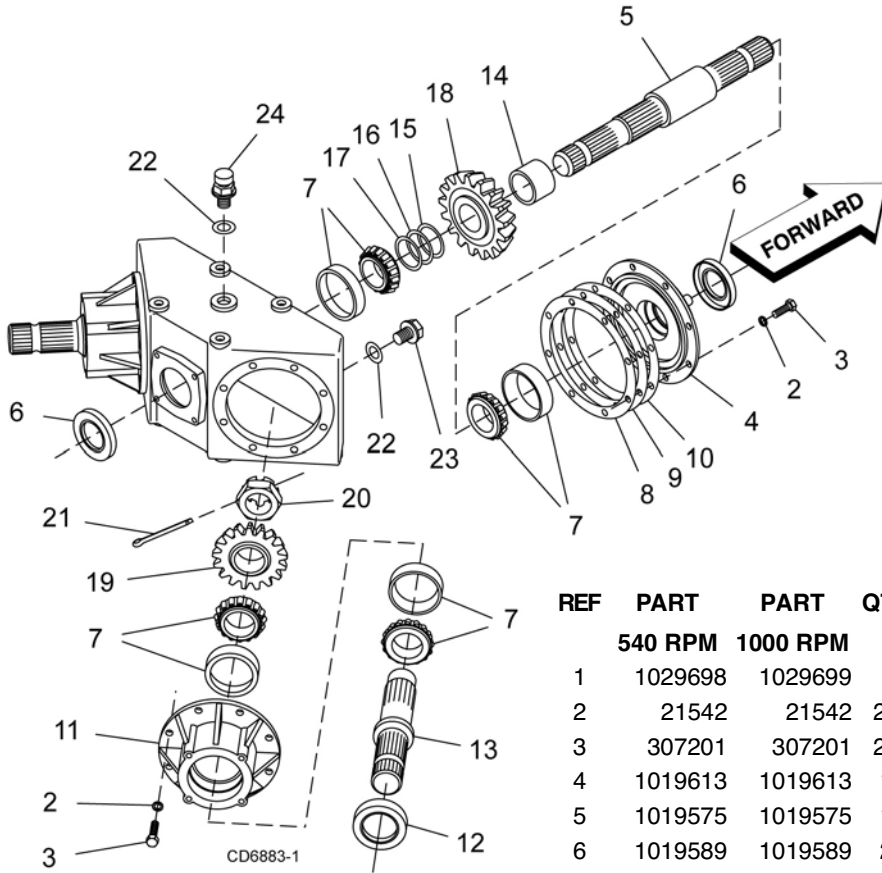

REF	PART	PART	QTY	DESCRIPTION
	540 RPM	1000 RPM		
1	1029698	1029699	-	Complete splitter gearbox
2	21542	21542	24	10 mm Lock washer
3	307201	307201	24	M10-1.5 x 30 HHCS
4	1019613	1019613	1	Input cap
5	1019575	1019575	1	Input shaft
6	1019589	1019589	2	Input oil seal
7	1019587	1019587	6	Bearing assembly (cup and cone)
8	1019592	1019592	A/S	Gasket .15 mm
9	1019593	1019593	A/S	Gasket .25 mm
10	1019594	1019594	A/S	Gasket .45 mm
11	1019612	1019612	2	Hub cap
12	1019590	1019590	2	Oil seal
13	1019576	1019576	2	Output shaft
14	1019603	1019603	1	Spacer
15	1019609	1019609		Shim .30 mm
16	1019608	1019608		Shim .40 mm
17	1019610	1019610		Shim .50 mm
18	1027170	1027184	1	Center gear
19	1027184	1027170	2	Wing gear
20	1019605	1019605	2	Bearing adjustment nut
21	-----	-----	2	1/8 x 2-1/2 Cotter pin
22	1009081	1009081	2	Sealing washer
23	1019601	1019601	1	M18 x 1.5 Level plug
24	1019600	1019600	1	M18 x 1.5 Breather plug

A/S As required

CENTER DECK DRIVE ASSEMBLY

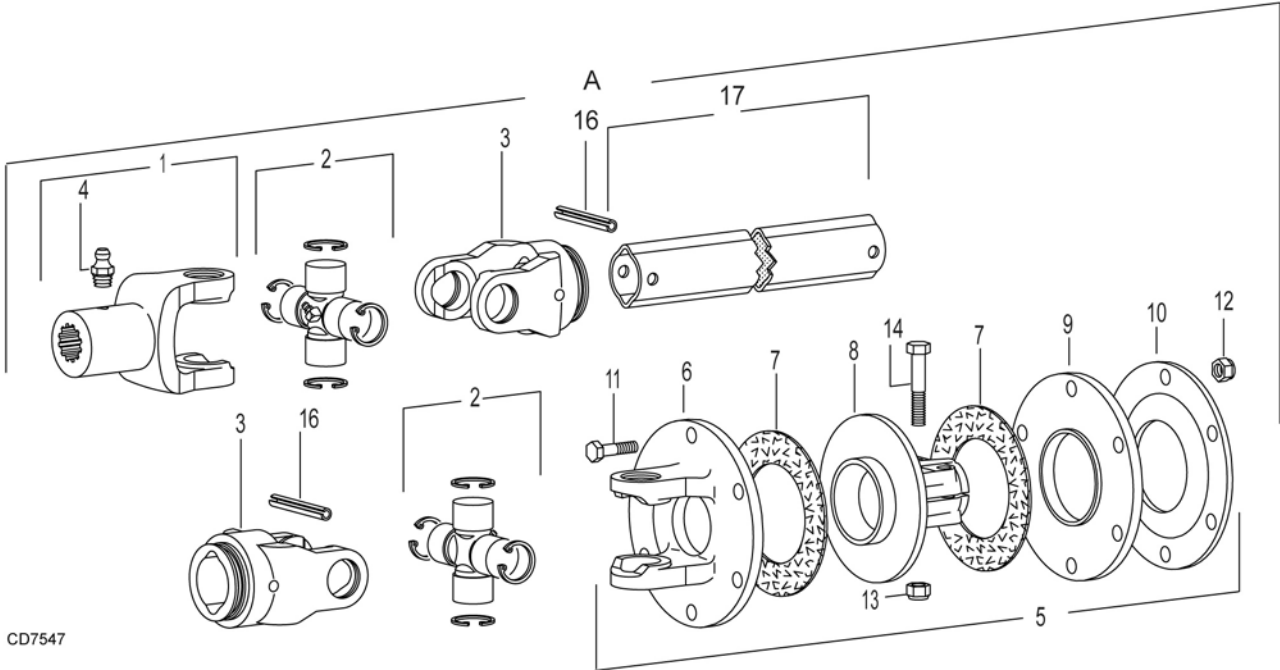

CD7547

REF	PART	QTY	DESCRIPTION
A	1027297	1	Complete center drive assembly
1	1004961	1	Yoke, 1-3/4, 20 spline
2	110	2	Cross & bearing kit
3	40576	1	Inboard yoke
4	1005521	1	Grease fitting
5	57416	1	Friction clutch 1340 1-3/4, 20 spline
6	57438	1	Flange yoke
7	57432	2	Friction disc
8	57440	1	Hub, 1-3/4, 20 spline

REF	PART	QTY	DESCRIPTION
9	57434	1	Thrust plate
10	57439	1	Belleville spring plate
11	57259	6	M10 x 1.5P x 55 mm Cap screw 8.8
12	57260	6	M10 x 1.5P Hex lock nut
13	57261	2	M12 x 1.75P Hex lock nut
14	57262	2	M12 x 1.75P x 65 mm Cap screw 8.8
15	1005508		Clutch repair kit
16	40764	2	Spring pin 10 x 60
17	1019110	1	Outer profile

FRONT 3-JOINT DRIVE ASSEMBLY (EQUAL ANGLE) 540 ONLY

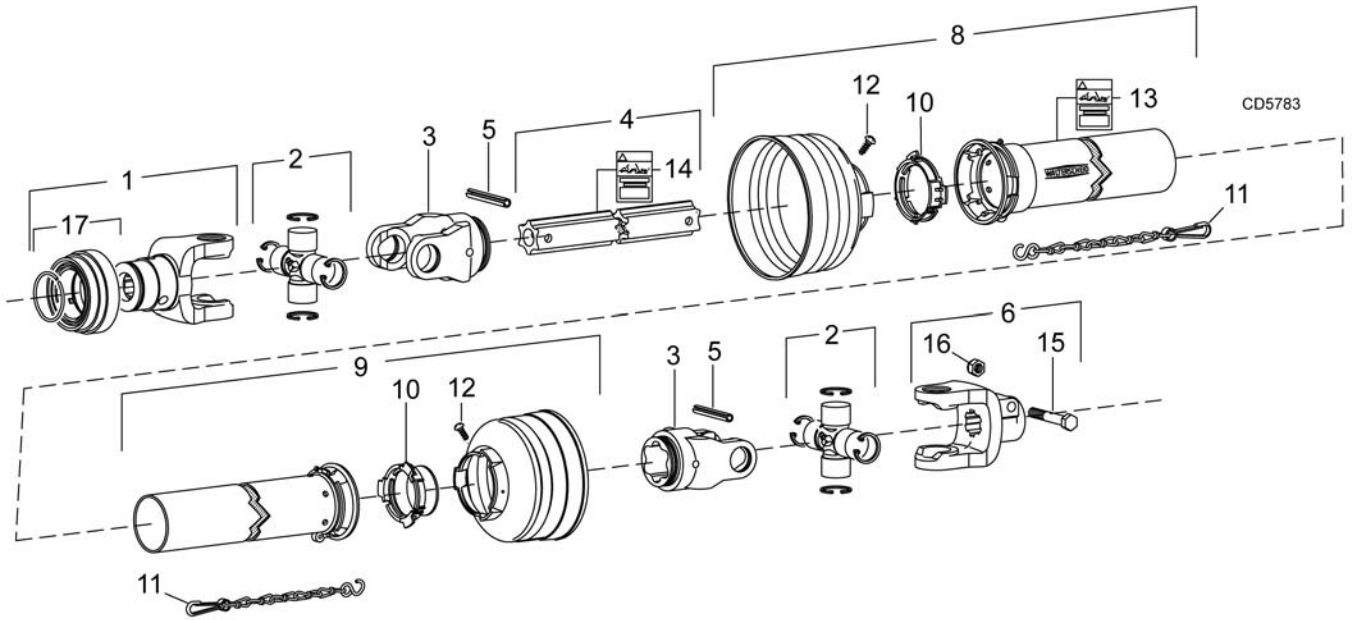

REF	PART	QTY	DESCRIPTION	REF	PART	QTY	DESCRIPTION
A	57282	1	Complete 540 RPM (6 spline)	9	40728	1	Inner shield
1	40563	1	Yoke 1-3/8 - 6 spline (540 RPM)	10	40766	2	Bearing ring SC25
2	40566	2	Cross & bearing	11	40777	2	Anti-rotation chain
3	40751	2	Inboard yoke	12	40778	2	Screw
4	40753	1	Outer profile	13	18864	1	Danger decal, rotating driveline
5	40765	2	Spring pin 10 x 90	14	33347	1	Danger decal, shield missing
6	57299	1	Yoke 1-1/2 - 23 spline I.C.	15	19811	1	1/2 NC x 2 HHCS GR8
8	40727	1	Outer shield	16	765	1	1/2 NC Lock nut
				17	40758	1	Lock collar kit (540 RPM 6 spline 1-3/8)

60 Parts

MAN0763 (10/10/2008)

REAR 3-JOINT DRIVE ASSEMBLY (EQUAL ANGLE)

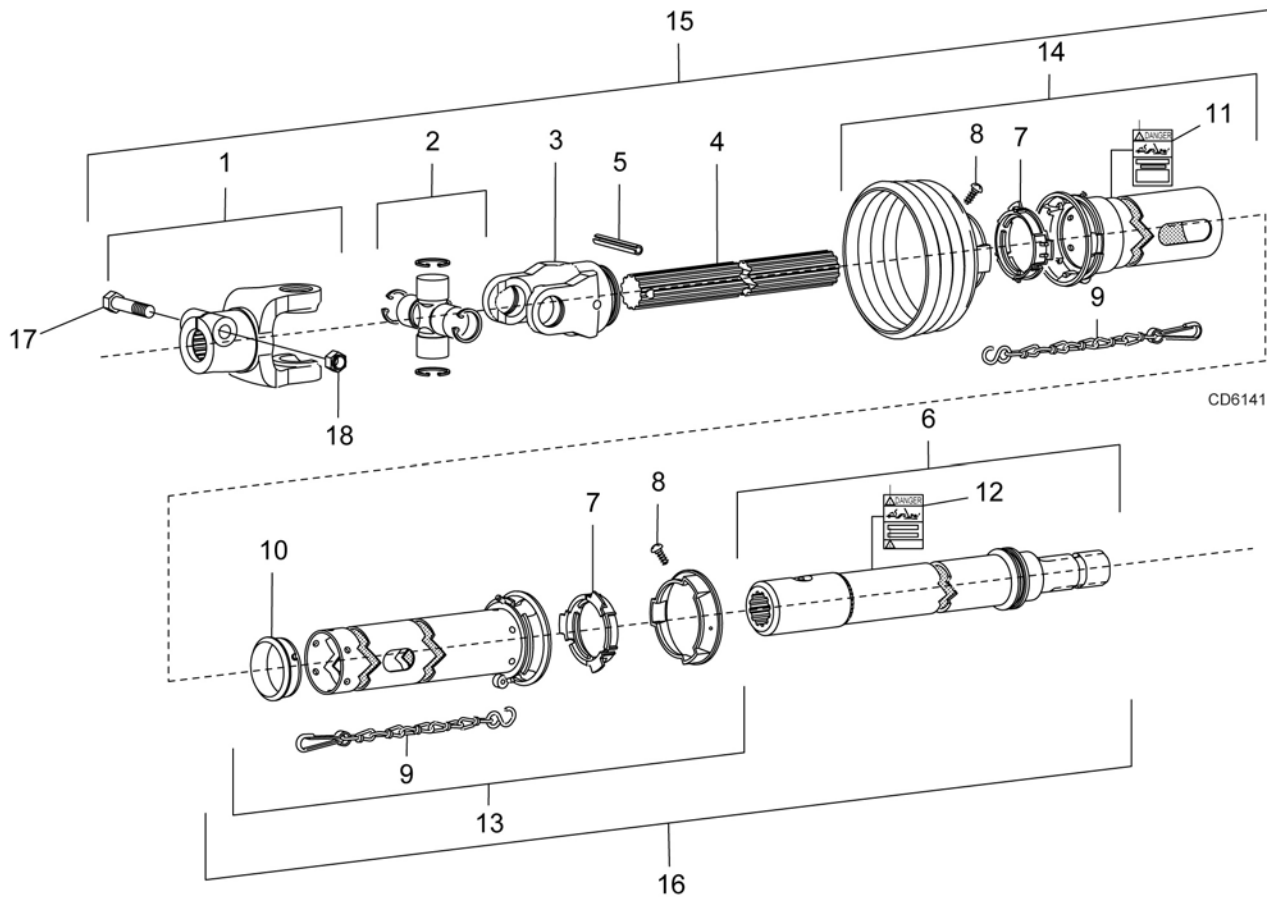

REF	PART	QTY	DESCRIPTION	REF	PART	QTY	DESCRIPTION
A	1004932	1	Complete rear drive assembly	9	40777	2	Anti-rotation chain
1	1004957	1	Yoke, 1-3/4, 20 spline	10	40767	1	Support bearing
2	40566	1	Cross and bearing	11	18864	1	Decal, danger rotating driveline
3	1003471	1	Inboard yoke	12	33347	1	Decal, danger guard missing
4	1004958	1	Inner profile	13	1004960	1	Inner guard half
5	40765	1	Spring pin 10 x 90	14	1004959	1	Outer guard half
6	1029936	1	Stub shaft	17	1001042	1	M16 x 2.0P x 90 mm HHCS 8.8
7	40766	2	Bearing ring SC25	18	1005522	1	M16 x 2.0P Hex lock nut
8	40778	2	Screw (package of 10)				

TYPE A - 540 RPM FRONT CV DRIVE

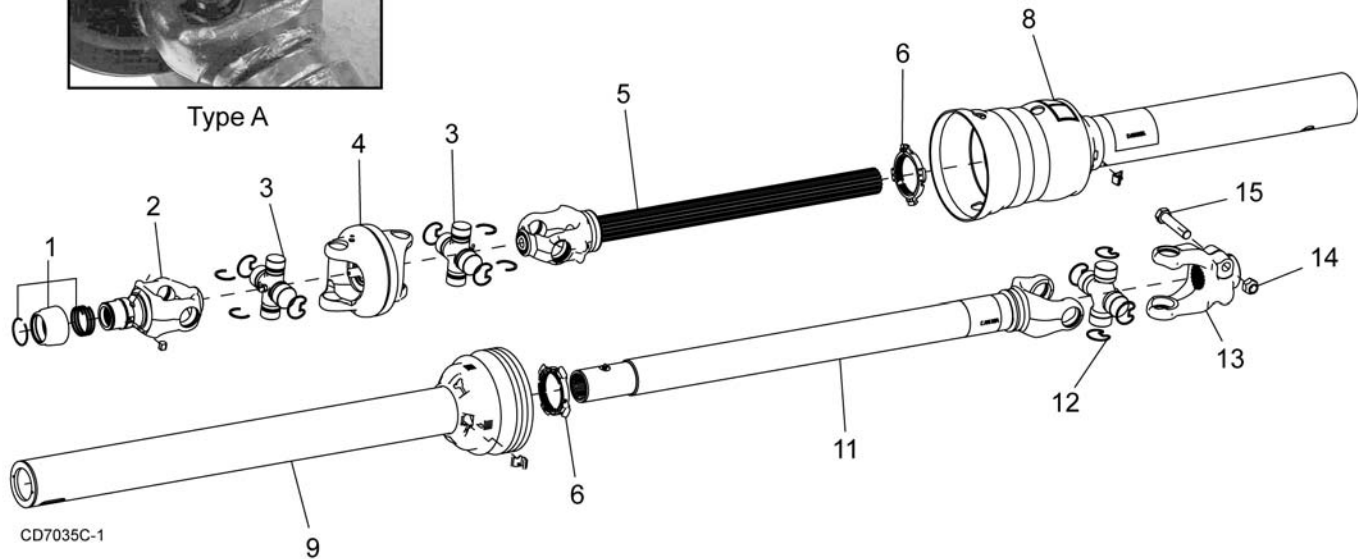

Note 1: Two types of Weasler drives are used on BW240HD's. See photo to determine type.

Note 2: Lube fitting in center of cross and bearing.

REF	PART	QTY	DESCRIPTION	REF	PART	QTY	DESCRIPTION
A	1021103	1	Complete CV drive (540 RPM)	9	1021315	1	CV shield inner (540 RPM)
1	19851	1	Slide lock repair kit	10	33347 †	1	Decal, danger guard missing (see page 13)
2	58774	1	Yoke QD CV 1.375 - 6 (540 RPM)	11	1021316	1	Yoke, tube & sleeve 55R x 36.4 x 1.69 - 20 (540 RPM)
3	58759	2	CV U-Joint repair kit Cat 6 55E	12	58765	1	U-Joint cross and bearing kit
4	58760	1	CV Body with fitting	13	1023058	1	Yoke, 55R x 5.06 x SP 1.75 - 20
5	1021313	1	Yoke and shaft CV splined 25.9 (540 RPM)	14	6239 *	1	5/8 NC Lock nut
6	1009065	2	Drive shield bearing kit	15	34473 *	1	5/8 NC x 3 HHCS GR5
7	18864 †	1	Decal, danger rotating driveline (see page 12)				
8	1021314	1	CV shield outer (540 RPM)				

† Not shown

HHCS Hex Head Cap Screw

* Standard hardware, obtain locally

TYPE B - 540 RPM FRONT CV DRIVE



Type B

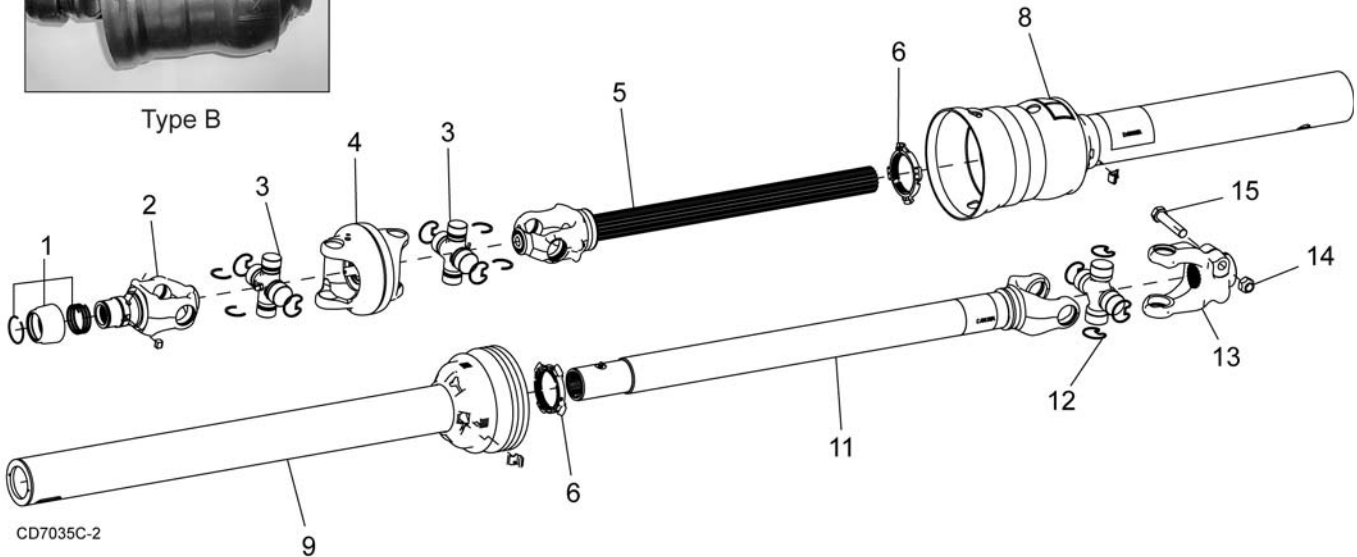

Note 1: Two types of Weasler drives are used on BW240HD's. See photo to determine type.

Note 2: Lube fitting at end of cross and bearing.

REF	PART	QTY	DESCRIPTION	REF	PART	QTY	DESCRIPTION
A	1021103	1	Complete CV drive (540 RPM)	9	1021315	1	CV shield inner (540 RPM)
1	19851	1	Slide lock repair kit	10	33347 †	1	Decal, danger guard missing (see page 13)
2	1033103	1	Yoke QD CV 1.375 - 6 (540 RPM)	11	1021316	1	Yoke, tube & sleeve 55R x 36.4 x 1.69 - 20 (540 RPM)
3	1033107	2	CV U-Joint repair kit Cat 6 55E	12	58765	1	U-Joint cross and bearing kit
4	1033106	1	CV Body with fitting	13	1023058	1	Yoke, 55R x 5.06 x SP 1.75 - 20
5	1033113	1	Yoke and shaft CV splined 25.9 (540 RPM)	14	6239 *	1	5/8 NC Lock nut
6	1009065	2	Drive shield bearing kit	15	34473 *	1	5/8 NC x 3 HHCS GR5
7	18864 †	1	Decal, danger rotating driveline (see page 12)				
8	1021314	1	CV shield outer (540 RPM)				

† Not shown

HHCS Hex Head Cap Screw

* Standard hardware, obtain locally

TYPE A - 1000 RPM FRONT CV DRIVE



Type A

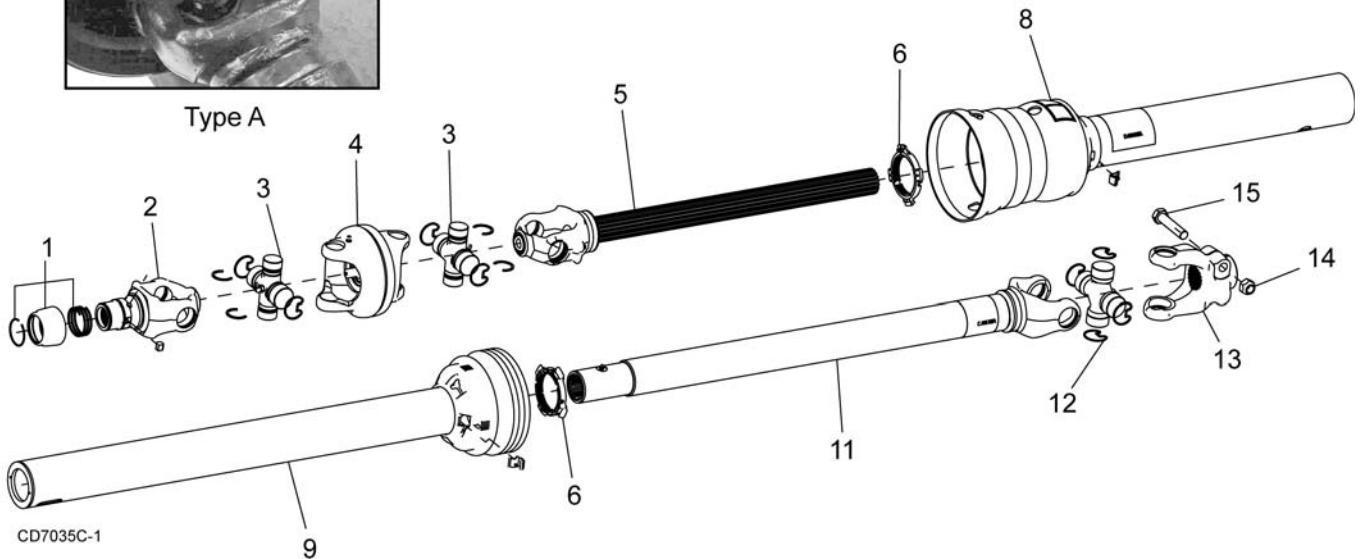

Note 1: Two types of Weasler drives are used on BW240HD's. See photo to determine type.

Note 2: Lube fitting in center of cross and bearing.

1000 RPM 1-3/8 21-Splined

REF	PART	QTY	DESCRIPTION
A	1021104	1	Complete CV drive assembly
1	19851	1	Slide lock repair kit
2	58770	1	Yoke QD CV 1.375 - 21
3	58759	2	CV U-Joint repair kit, cat 6 55E
4	58760	1	CV body with fitting
5	1021317	1	Yoke and shaft - CV splined 26.6
6	1009065	2	Drive shield bearing kit
7	18864 †	1	Decal, danger rotating driveline (see page 12)
8	1021318	1	CV shield outer
9	1021319	1	CV shield inner
10	33347 †	1	Decal, danger guard missing (see page 13)
11	1021320	1	Yoke, tube & sleeve 55R x 38.4 x 1.69 - 20
12	58765	1	U-Joint cross and bearing kit 55E
13	1023058	1	Yoke, 55R x 5.06 x SP 1.75 - 20
14	6239	1	Nut, lock 5/8 NC
15	34473	1	HHCS 5/8 NC x 3 GR5

† Not shown
 HHCS Hex Head Cap Screw
 * Standard hardware, obtain locally

1000 RPM 1-3/4 20-Splined

REF	PART	QTY	DESCRIPTION
A	1021105	1	Complete CV drive assembly
1	19837	1	Slide lock repair kit
2	58758	1	Yoke QD CV 1.75 - 20
3	58759	2	CV U-Joint repair kit, cat 6 55E
4	58760	1	CV body with fitting
5	1023154	1	Yoke and shaft - CV splined 30.9
6	1009065	2	Drive shield bearing kit
7	18864 †	1	Decal, danger rotating driveline (see page 12)
8	1023155	1	CV shield outer
9	1023156	1	CV shield inner
10	33347 †	1	Decal, danger guard missing (see page 13)
11	1023157	1	Yoke, tube & sleeve 55R x 39.8 x 1.69 - 20
12	58765	1	U-Joint cross and bearing kit 55E
13	1023058	1	Yoke, 55R x 5.06 x SP 1.75 - 20
14	6239	1	Nut, lock 5/8 NC
15	34473	1	HHCS 5/8 NC x 3 GR5

† Not shown
 HHCS Hex Head Cap Screw
 * Standard hardware, obtain locally

TYPE B - 1000 RPM FRONT CV DRIVE

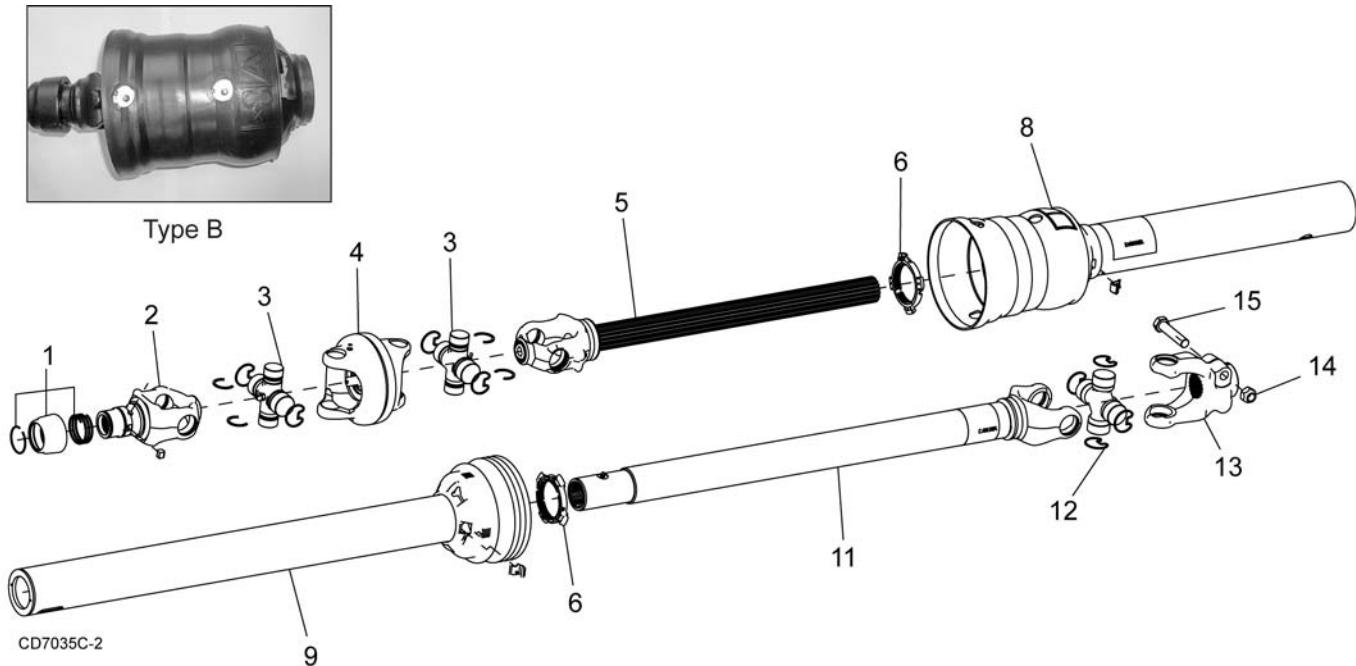

Note 1: Two types of Weasler drives are used on BW240HD's. See photo to determine type.

Note 2: Lube fitting at end of cross and bearing.

1000 RPM 1-3/8 21-Splined

REF	PART	QTY	DESCRIPTION
A	1021104	1	Complete CV drive assembly
1	19851	1	Slide lock repair kit
2	1033104	1	Yoke QD CV 1.375 - 21
3	1033107	2	CV U-Joint repair kit, cat 6 55E
4	1033106	1	CV body with fitting
5	1033111	1	Yoke and shaft - CV splined 26.6
6	1009065	2	Drive shield bearing kit
7	18864 †	1	Decal, danger rotating driveline (see page 12)
8	1021318	1	CV shield outer
9	1021319	1	CV shield inner
10	33347 †	1	Decal, danger guard missing (see page 13)
11	1021320	1	Yoke, tube & sleeve 55R x 38.4 x 1.69 - 20
12	58765	1	U-Joint cross and bearing kit 55E
13	1023058	1	Yoke, 55R x 5.06 x SP 1.75 - 20
14	6239	1	Nut, lock 5/8 NC
15	34473	1	HHCS 5/8 NC x 3 GR5

† Not shown
 HHCS Hex Head Cap Screw
 * Standard hardware, obtain locally

1000 RPM 1-3/4 20-Splined

REF	PART	QTY	DESCRIPTION
A	1021105	1	Complete CV drive assembly
1	19837	1	Slide lock repair kit
2	1033105	1	Yoke QD CV 1.75 - 20
3	1033107	2	CV U-Joint repair kit, cat 6 55E
4	1033106	1	CV body with fitting
5	1033116	1	Yoke and shaft - CV splined 30.9
6	1009065	2	Drive shield bearing kit
7	18864 †	1	Decal, danger rotating driveline (see page 12)
8	1023155	1	CV shield outer
9	1023156	1	CV shield inner
10	33347 †	1	Decal, danger guard missing (see page 13)
11	1023157	1	Yoke, tube & sleeve 55R x 39.8 x 1.69 - 20
12	58765	1	U-Joint cross and bearing kit 55E
13	1023058	1	Yoke, 55R x 5.06 x SP 1.75 - 20
14	6239	1	Nut, lock 5/8 NC
15	34473	1	HHCS 5/8 NC x 3 GR5

† Not shown
 HHCS Hex Head Cap Screw
 * Standard hardware, obtain locally

WING DRIVE ASSEMBLY

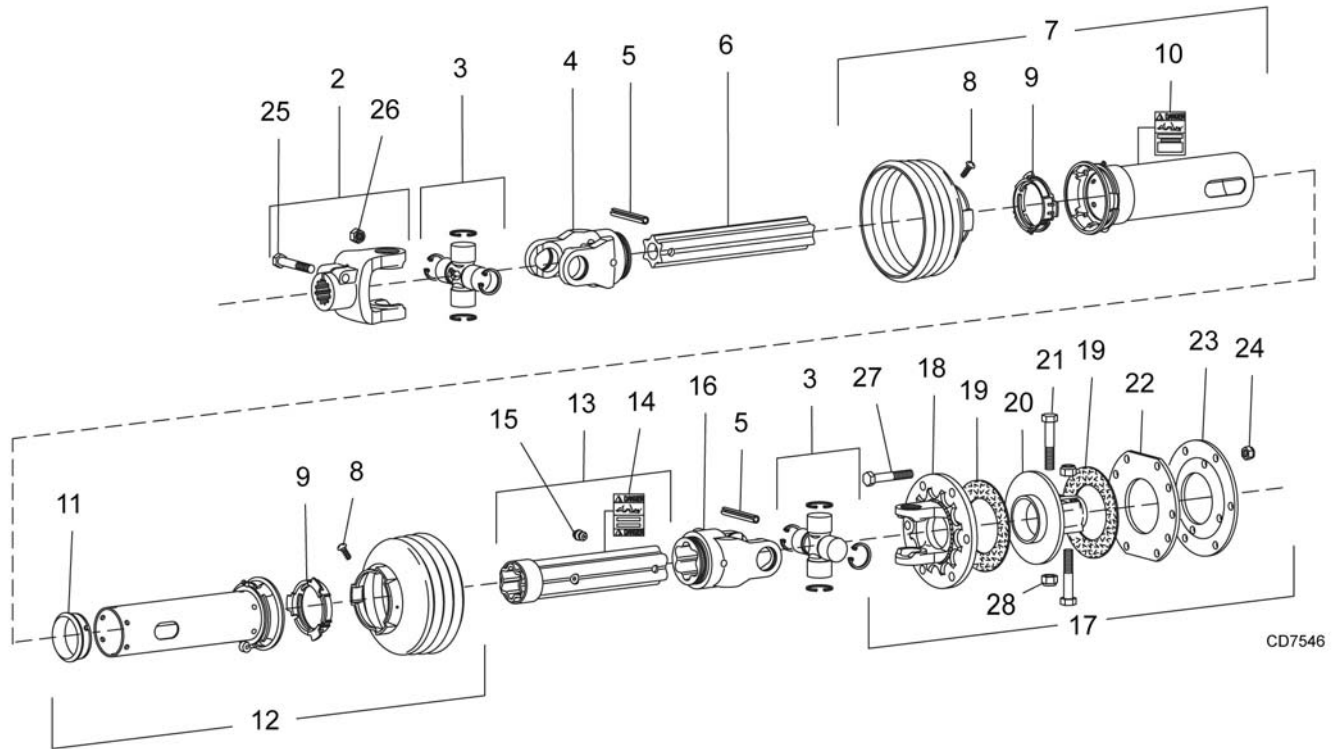

CD7546

REF	PART	QTY	DESCRIPTION	REF	PART	QTY	DESCRIPTION
1	1027296		Complete wing drive assembly	15	40779	1	Grease fitting
2	1019111	1	Yoke 1-3/4 20 special	16	44677	1	Inboard yoke S5
3	38352	2	Cross and bearing kit 2400	17	1019114	1	Clutch (includes 18 thru 24, 27,28)
4	90317352	1	Inboard yoke S4	18	1027217	1	Flange yoke
5	40764	2	Spring pin 10 x 80	19	57432	2	Friction disc
6	1019112	1	Inner profile S4L	20	57440	1	Hub 1-3/4 20
7	1019115	1	Outer shield	21	57262	2	M12 x 1.75P x 65 mm HHCS 8.8
8	40778	2	Screw (package of 10)	22	57434	1	Thrust plate
9	40766	1	Bearing ring	23	57439	1	Belleville spring plate
10	18864	1	Decal, Danger Rotating Driveline	24	57260	6	M10 x 1.5P Hex lock nut
11	40767	1	Support bearing	25	307309	2	M12 x 1.75P x 60 mm HHCS 8.8
12	1019116	1	Inner shield	26	58549	2	M12 x 1.75P Hex Lock nut
13	1019113	1	Profile and sleeve	27	57259	6	M10 x 1.5P x 55 mm HHCS 8.8
14	33347	1	Decal, Danger Guard Missing	28	57261	2	M12 x 1.75P Hex lock nut

HHCS Hex Head Cap Screw

66 Parts

MAN0763 (10/10/2008)

5-BOLT WHEEL & TIRE ASSEMBLY

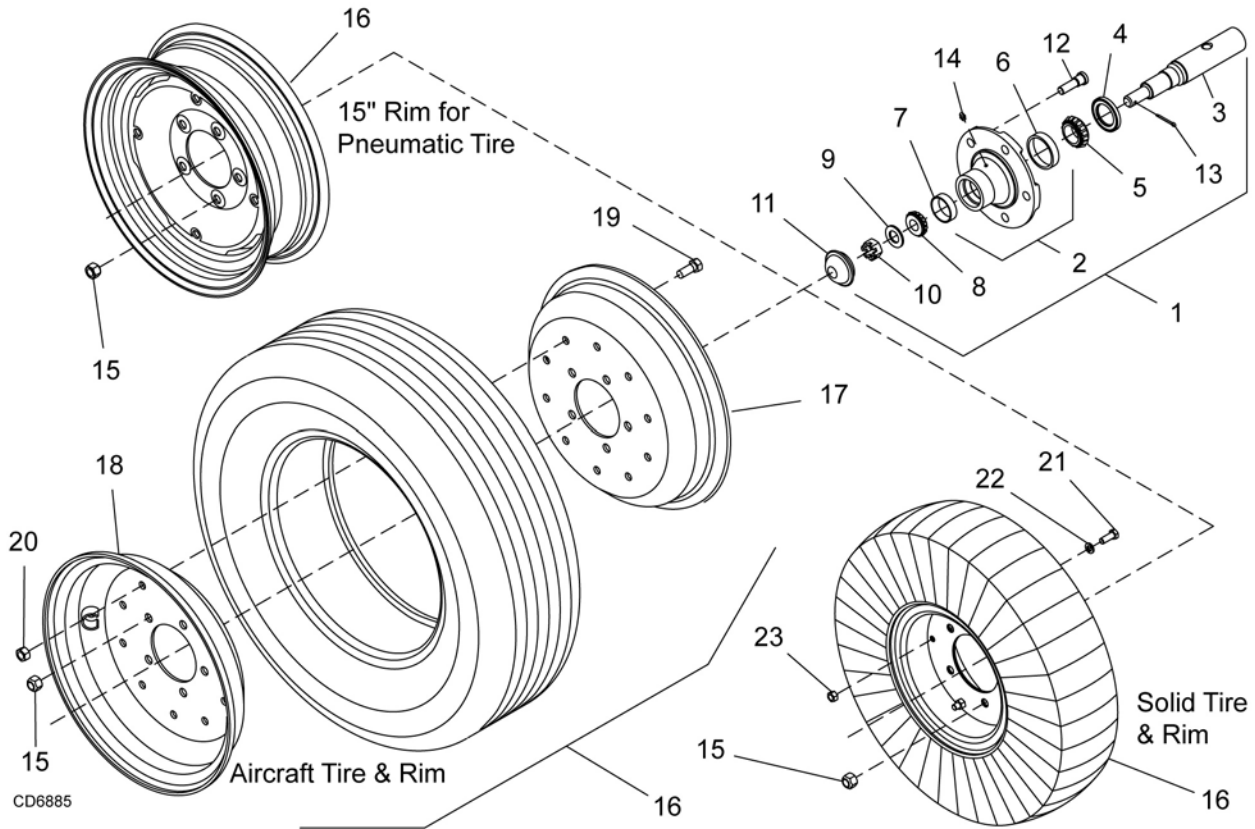

CD6885

REF	PART	QTY	DESCRIPTION	REF	PART	QTY	DESCRIPTION
1	1017050	1	Heavy hub assembly (includes items 1 through 15)	16	1028820F	1	24 x 7.25 x 12 Aircraft tire, rim & hardware, foam filled - 5 bolt
2	1017034	1	Heavy wheel hub with cups (includes items 6,7,14)	16	1017030	1	29 x 9 x 15 Aircraft tire, rim & hardware - 5 bolt
3	1017033	1	Axle	17	1028821	1	12.0 x 6 Rim half (for 24" aircraft wheel only) -or-
4	1017027	1	Seal	17	1017026	1	15.0 x 6.0 Rim half (for 29" aircraft wheel only)
5	1017028	1	Bearing cone	18	1028822	1	12.0 x 6 Rim half (for 24" aircraft wheel only)
6	1017036	1	Bearing cup	18	1017025	1	15.0 x 6.0 Rim half w/ valve hole (for 29" aircraft wheel only)
7	1017037	1	Bearing cup	19	6100 *		1/2 NC x 1-1/4 HHCS GR5
8	1017029	1	Bearing cone	20	765 *		1/2 NC Lock nut
9	1017031	1	Washer	21	19887 *		3/8 NC x 1 HHCS GR8
10	1017032	1	Castle nut	22	838 *		3/8 Standard lock washer
11	1017035	1	Hub cap	23	835 *		3/8 NC Hex nut
12	1017038	5	Stud	-	1015833	1	29 x 9 x 15 Inner tube (for 29" aircraft wheel only)
13	1017069	1	Cotter pin	-	1017042	2	Rim half for 6 x 9 solid tire
14	1017067	1	Grease fitting				
15	35317	5	Nut, lug 1/2 NF				
16	1017088	1	15" Rim for pneumatic tire - 5 bolt -or-				
16	1017040	1	6.00 x 9 Solid tire, rim & hardware - 5 bolt -or-				
16	1028820	1	24 x 7.25 x 12 Aircraft tire, rim & hardware - 5 bolt -or-				

* Standard hardware, obtain locally

RUBBER SHIELDING - CENTER SECTION (STANDARD)

REF	PART	QTY	DESCRIPTION
1	1027164	1	Front center belt shield plate
2	1027166	1	Front right belt shield plate
3	1027167	1	Front left belt shield plate
4	1027176	4	Bent link .25 x 1.61 x 12.00
5	1027284	2	Rubber shield .25 x 8.50 x 44.74
6	1027289	2	Rubber shield .25 x 8.88 x 32.50
14	6697	*	3/8 NC x 1 Carriage bolt GR5
15	14350	*	3/8 NC Flanged lock nut

* Standard hardware, obtain locally

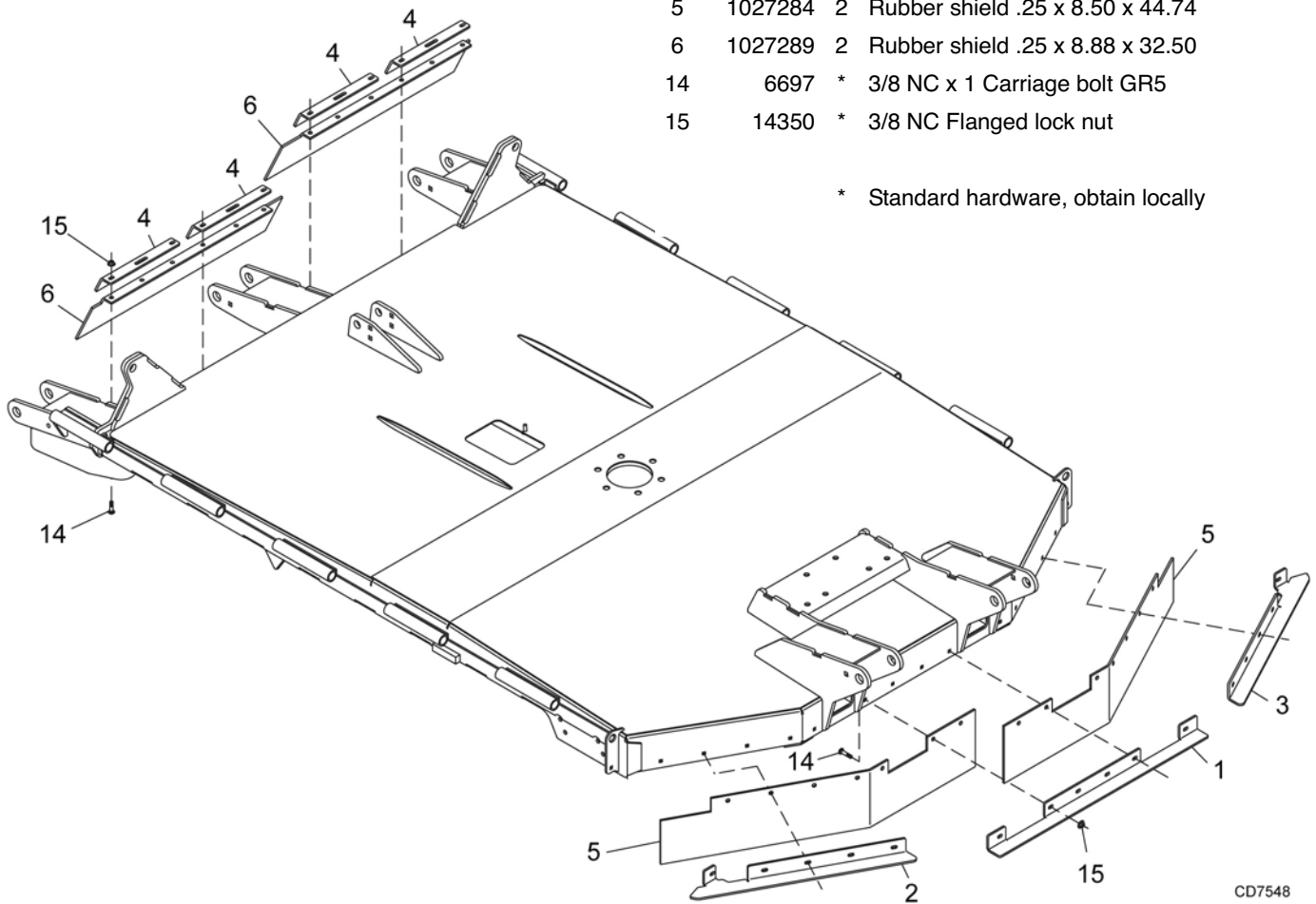

CD7548

RUBBER SHIELDING - WING (STANDARD)

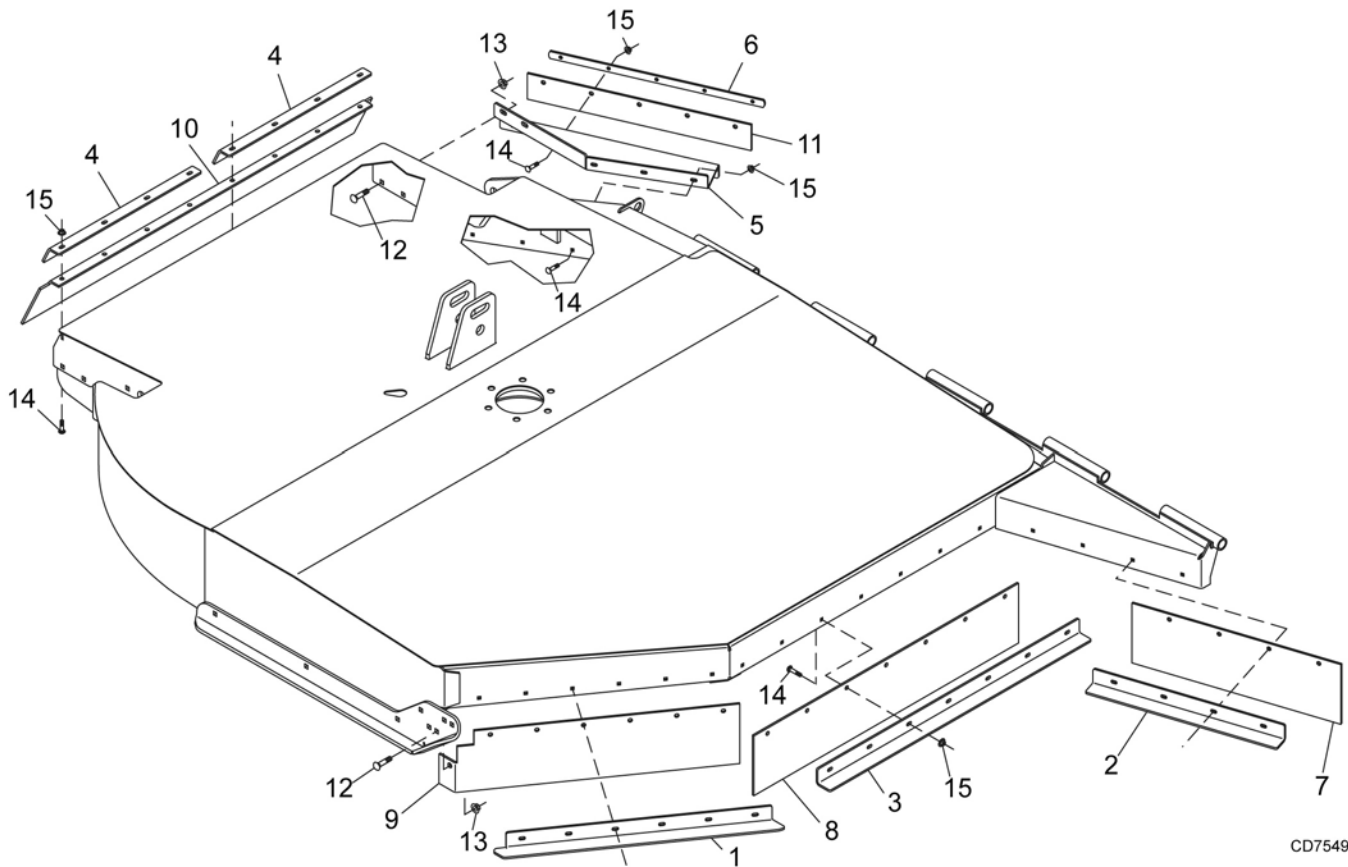

CD7549

REF	PART	QTY	DESCRIPTION	REF	PART	QTY	DESCRIPTION
1	1027168	1	Front right wing belt shield plate, outer - or -	8	1027286	1	Rubber shield .25 x 8.50 x 43.50
1	1027169	1	Front left wing belt shield plate, outer	9	1027287	1	Rubber shield .25 x 8.50 x 36.05
2	1027171	1	Front wing belt shield plate, inner	10	1027288	1	Rubber shield .25 x 8.88 x 54.50
3	1027172	1	Front wing belt shield plate, center	11	1027290	1	Rubber shield .25 x 3.64 x 28.00
4	1027176	2	Bent link .25 x 1.61 x 23.50	12	29893	*	1/2 NC x 1-1/2 Carriage bolt GR5
5	1027174	1	Rear right wing belt shield plate, inner - or -	13	11900	*	1/2 NC Flanged lock nut
5	1027175	1	Rear left wing belt shield plate, inner	14	6697	*	3/8 NC x 1 Carriage bolt GR5
6	1027177	1	Link .25 x 1.00 x 27.00	15	14350	*	3/8 NC Flanged lock nut
7	1027285	1	Rubber shield .25 x 8.50 x 27.25				

* Standard hardware, obtain locally

CHAIN SHIELDING - CENTER SECTION (OPTIONAL)

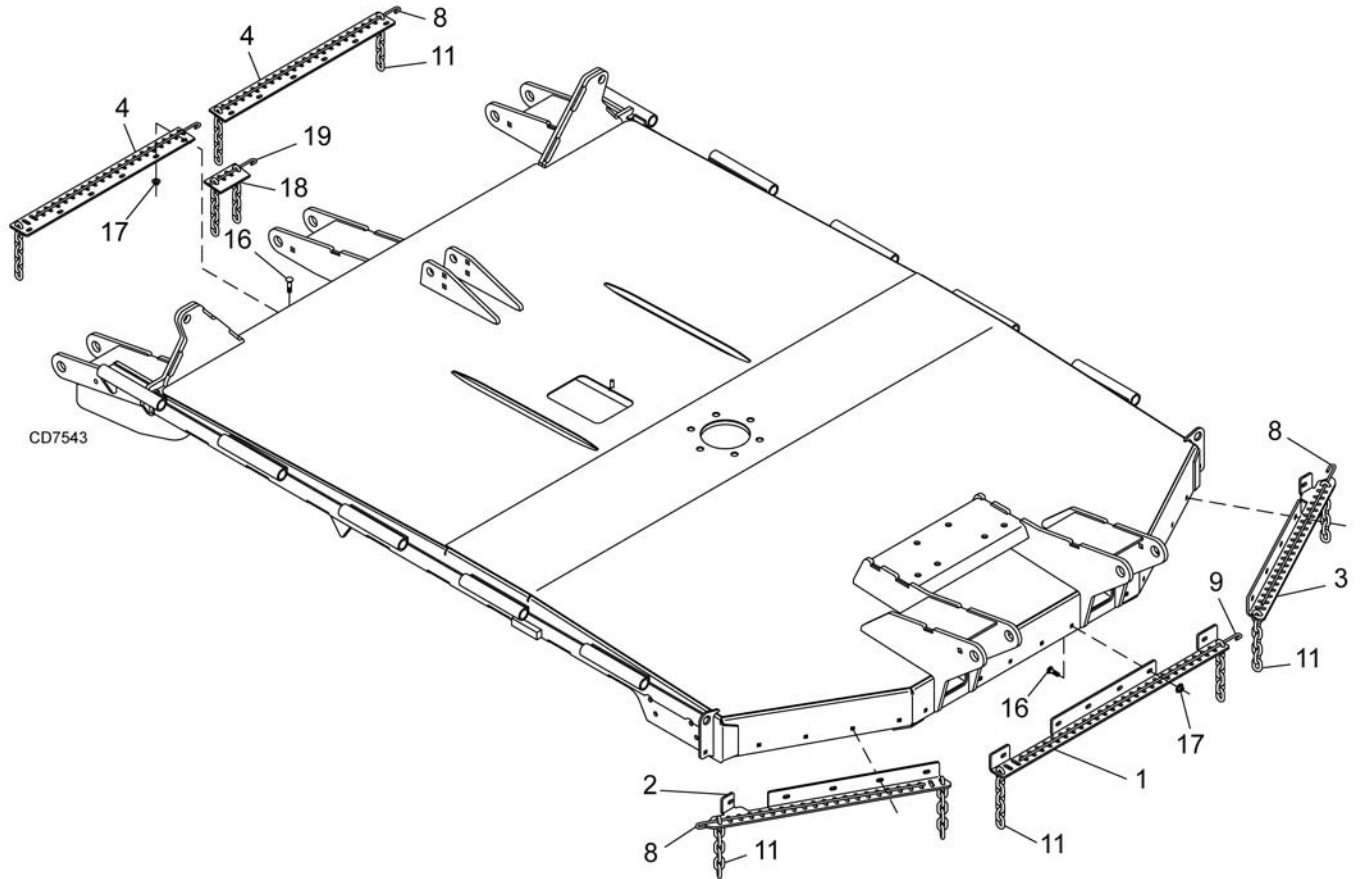

SINGLE ROW

REF	PART	QTY	DESCRIPTION
1	1027131	1	Front center chain plate
2	1027132	1	Front right chain plate
3	1027133	1	Front left chain plate
4	1027141	2	Rear chain plate
8	1003644	4	Pin, 22 to 24 chains
9	1003646	1	Pin, 28 to 30 chains
11	5496	123	5/16 Chain - 7 link
16	6697	*	3/8 NC x 1 Carriage bolt GR5
17	14350	*	3/8 NC Flanged lock nut
18	1027189	1	Rear chain plate, center short
19	1007852	1	Pin, 7 to 9 chains

* Standard hardware, obtain locally

DOUBLE ROW

REF	PART	QTY	DESCRIPTION
1	1029881	1	Front center chain plate
2	1029882	1	Front right chain plate
3	1029883	1	Front left chain plate
4	1029888	2	Rear chain plate
8	1003644	8	Pin, 22 to 24 chains
9	1003646	2	Pin, 28 to 30 chains
11	5496	220	5/16 Chain - 7 link
16	6697	*	3/8 NC x 1 Carriage bolt GR5
17	14350	*	3/8 NC Flanged lock nut
18	1027291	1	Rear chain plate, center short
19	1007852	2	Pin, 7 to 9 chains

* Standard hardware, obtain locally

70 Parts

MAN0763 (10/10/2008)

CHAIN SHIELDING - WING (OPTIONAL)

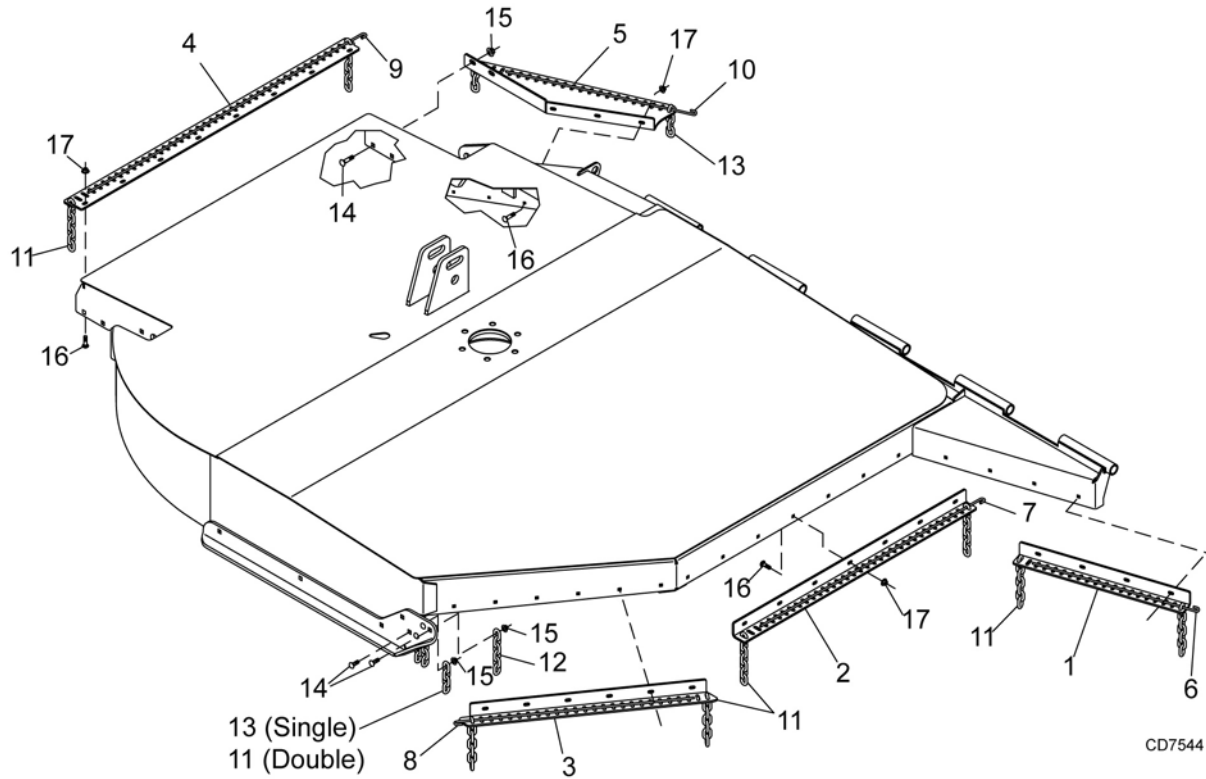

SINGLE ROW

REF	PART	QTY	DESCRIPTION
1	1027134	1	Front wing chain plate, inner
2	1027140	1	Front wing chain plate, center
3	1027136	1	Front right wing chain plate, outer - or -
3	1027137	1	Front left wing chain plate, outer
4	1027142	1	Rear wing chain plate
5	1027138	1	Rear right wing chain plate, inner - or -
5	1027139	1	Rear left wing chain plate, inner
6	1003643	1	Pin, 19 to 21 chains
7	1007851	1	Pin, 34 to 36 chains
8	1003645	1	Pin, 25 to 27 chains
9	1007854	1	Pin, 40 to 42 chains
10	1003644	1	Pin, 22 to 24 chains
11	5496	124	5/16 Chain - 7 link
12	5498	2	5/16 Chain - 6 link
13	4069	25	5/16 Chain - 4 link
14	29893	*	1/2 NC x 1-1/2 Carriage bolt GR5
15	11900	*	1/2 NC Flanged lock nut
16	6697	*	3/8 NC x 1 Carriage bolt GR5
17	14350	*	3/8 NC Flanged lock nut

* Standard hardware, obtain locally

DOUBLE ROW

REF	PART	QTY	DESCRIPTION
1	1029885	1	Front wing chain plate, inner
2	1029884	1	Front wing chain plate, center
3	1029886	1	Front right wing chain plate, outer - or -
3	1029887	1	Front left wing chain plate, outer
4	1029889	1	Rear wing chain plate
5	1029890	1	Rear right wing chain plate, inner - or -
5	1029891	1	Rear left wing chain plate, inner
6	1003643	2	Pin, 19 to 21 chains
7	1007851	2	Pin, 34 to 36 chains
8	1003645	2	Pin, 25 to 27 chains
9	1007854	2	Pin, 40 to 42 chains
10	1003644	2	Pin, 22 to 24 chains
11	5496	217	5/16 Chain - 7 link
12	1016953	2	5/16 Chain - 11 link
13	4069	38	5/16 Chain - 4 link
14	29893	*	1/2 NC x 1-1/2 Carriage bolt GR5
15	11900	*	1/2 NC Flanged lock nut
16	6697	*	3/8 NC x 1 Carriage bolt GR5
17	14350	*	3/8 NC Flanged lock nut

* Standard hardware, obtain locally

TANDEM AXLE WHEEL YOKE (OPTIONAL)

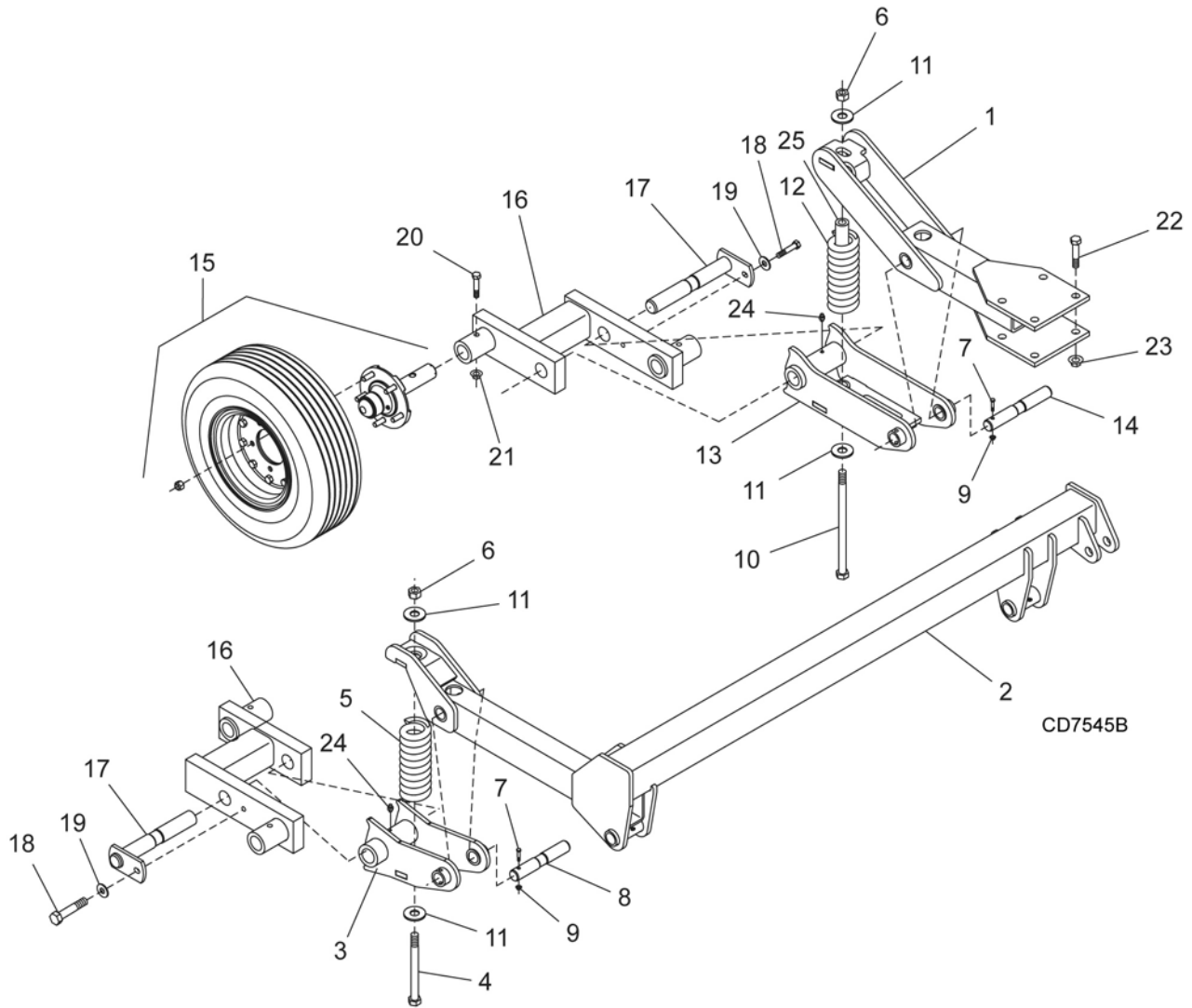

REF	PART	QTY	DESCRIPTION	REF	PART	QTY	DESCRIPTION
1	1024109	2	Wheel yoke arm, spring	11	11920	*	Washer, 1 x 1-7/8 x 1/4
2	1027080	1	Wheel yoke, spring right (for right wing) -or-	12	19710	2	Spring/cmp 3.25 .69. 9.52200
2	1027081	1	Wheel yoke, spring left (for left wing) (not shown)	13	1023170	2	Lower spring arm, tandem
3	1029876	1	Lower spring arm, wing right (for right wing) -or-	14	1017149	2	Bar drilled. 1.25 x 8.85
3	1029877	1	Lower spring arm, wing left (for left wing) (not shown)"	15	-----	8	Tire & hub assy (see page 67)
4	15087	*	1 NC x 9 HHCS GR5	16	1023166	4	Tandem
5	1032100	2	Spring, cmp 3.25x.56x7.3x1113	17	1017065	4	Flag pin 1.56 x 11.06
6	34279	*	1 NC Lock nut	18	6100	*	1/2 NC x 1-1/4 HHCS GR5
7	10509	*	5/16 NC x 2-1/2 HHCS GR5	19	854	*	Washer, 1/2 flat
8	52087	2	Bar, drilled 1.25 x 6.64 x 7.56	20	3489	*	1/2 NC x 3 HHCS GR5
9	14139	*	5/16 NC Flange lock nut	21	11900	*	1/2 NC Flange lock nut
10	1024122	*	1 NC x 13 HHCS GR5	22	2377	*	3/4 NC x 6 HHCS GR5
				23	2371	*	3/4 NC Lock nut
				24	12296	*	1/4-28 Grease fitting

* Standard hardware, obtain locally

72 Parts

(Rev. 9/4/2009)
MAN0763 (10/10/2008)

HYDRAULIC CYLINDERS

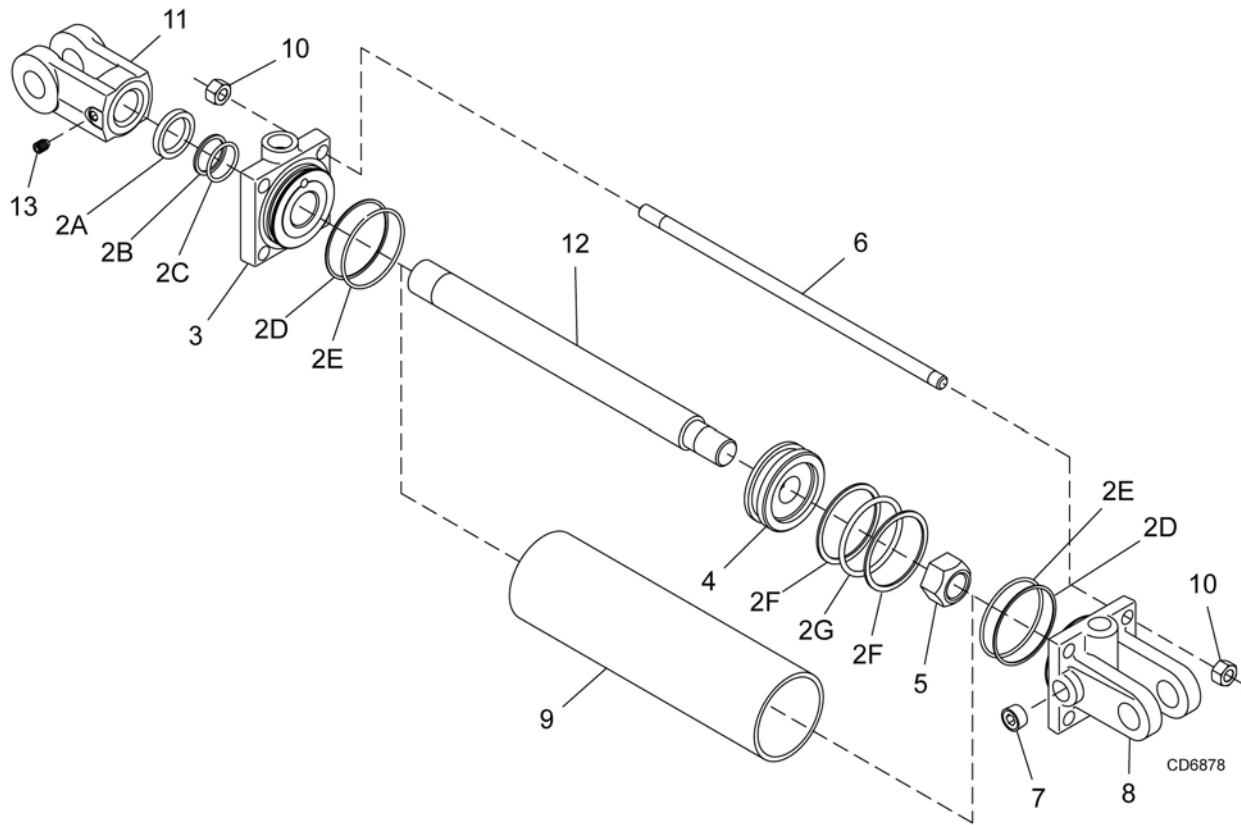

REF	3-1/2 x 8 PART	3-1/2 x 16 PART	QTY	DESCRIPTION
1	10475	52234		Complete cylinder
2	23540	23540	1	Seal repair kit (includes items 2A - 2G)
2A	†	†	1	Wiper seal
2B	†	†	1	Rod seal
2C	†	†	1	Rod O-ring
2D	†	†	2	Cap seal
2E	†	†	2	Cap O-ring
2F	†	†	2	Piston seal
2G	†	†	1	Piston O-ring
3	N/S	N/S	1	Cylinder housing - rod end
4	N/S	N/S	1	Piston
5	N/S	N/S	1	Jam nut
6	N/S	N/S	4	Cylinder tie rod
7	*	*	3	1/2 Pipe plug
8	N/S	N/S	1	Cylinder housing - butt end
9	N/S	N/S	2	Cylinder barrel
10	N/S	N/S	8	Tie rod nut
11	N/S	N/S	1	Cylinder clevis
12	N/S	N/S	1	Cylinder rod
13	*	*	1	Set screw 3/8 x 3/4 dog point

† Included in seal kit
 * Standard hardware, obtain locally
 N/S Not serviced

HYDRAULIC CYLINDER STROKE CONTROL KIT

REF	PART	QTY	DESCRIPTION
1	24098	1	Stroke control set for 1-1/4" cylinder rod (contains items 2 - 5)
2	----	2	1-1/2" Segment
3	----	1	1-1/4" Segment
4	----	1	1" Segment
5	----	1	3/4" Segment

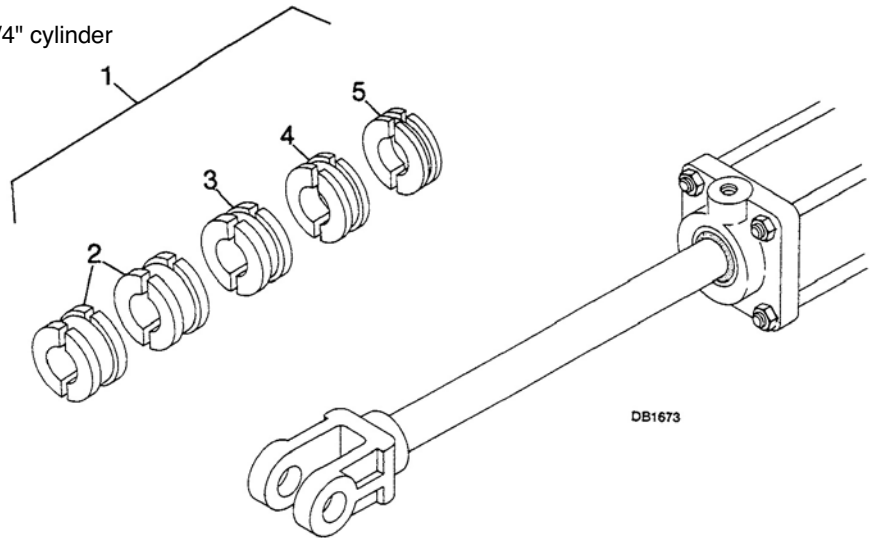

CROSSBAR PULLER (OPTIONAL)

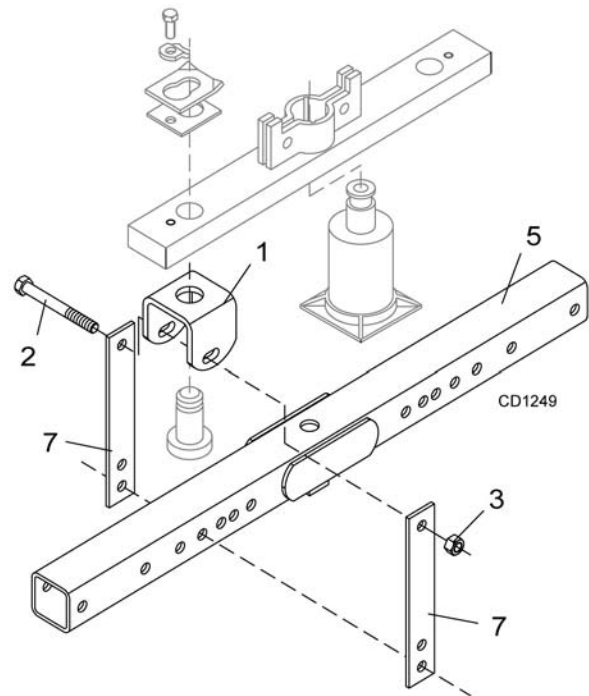
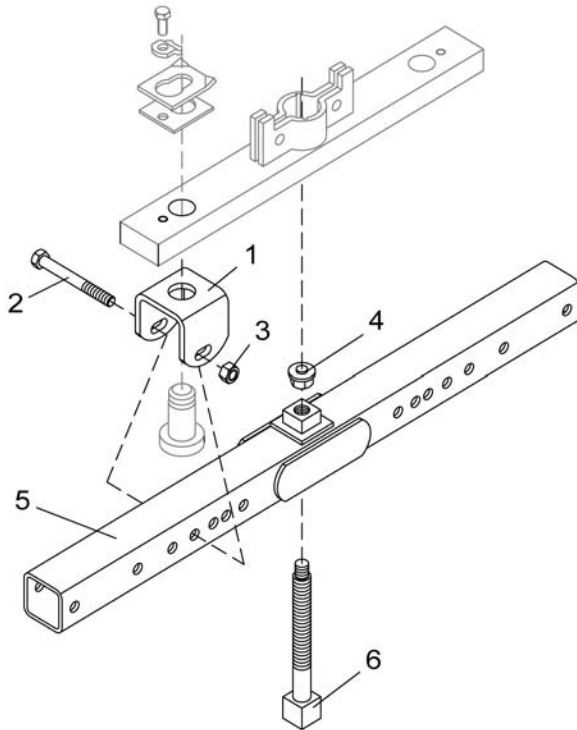

REF	PART	QTY	DESCRIPTION
A	8811	1	Crossbar puller, complete
1	19914	2	Crossbar puller clevis
2	3097 *	4	5/8 NC x 4-1/2 HHCS GR5
3	230 *	4	5/8 NC Hex nut

REF	PART	QTY	DESCRIPTION
4	24879	1	Crossbar puller pad assembly
5	24876	1	Crossbar puller tube assembly
6	24881	1	Crossbar puller screw assembly
7	24885	4	Crossbar puller link

* Standard hardware - obtain locally

74 Parts

MAN0763 (10/10/2008)

WINCH KIT (OPTIONAL)

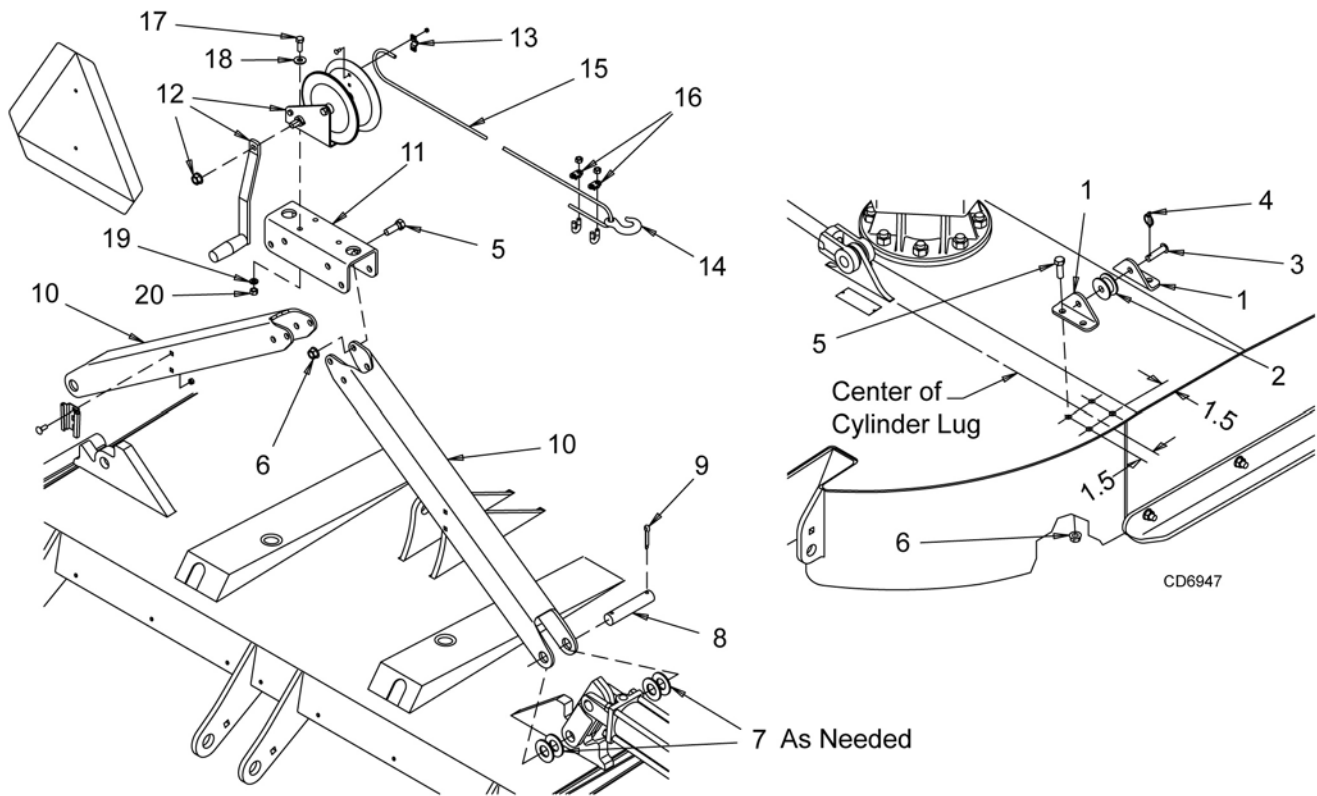

REF	PART	QTY	DESCRIPTION
A	1019456	-	Winch kit, complete
1	52478	4	Idler bracket
2	6696	2	Chain idler casting
3	409	2	Clevis pin, 1/2 x 2
4	22411	2	Klik pin, 3/16 x 1
5	3379 *	-	HHCS, 1/2 NC x 1-1/2 GR5
6	11900 *	-	Lock nut, 1/2 NC flanged
7	1863 *	-	Washer, 1" SAE flat
8	1008325	2	Headless pin, 1 x 4 drilled
9	1266 *	-	Cotter pin, 3/16 x 1-1/2
10	1027150	2	Channel, .25 x 2.56 x 2.75x 38.48
11	1027199	1	Channel, 3.12 x 3.25 x 10.00
12	12612	1	Gear winch 5.1 to 1
13	12642	1	Winch cable clamp kit
14	11790	1	C-Hook, 1/4 cable
15	52479	1	Cable, 1/4" x 24-ft
16	11789	2	Clip, 1/4 cable
17	839 *	-	HHCS, 3/8 NC x 1 GR5
18	565 *	-	Washer, 3/8 flat
19	838 *	-	Washer, 3/8 lock
20	835 *	-	Hex nut, 3/8 NC plated

* Standard hardware; obtain locally

Winch Kit Operation

1. Move cutter so wing is on the up slope of a ditch to aid in wing lift with the winch.
2. Unwind cable and remove roller (2).
3. Place cable around roller (2) and reinstall using pin (3) and klik pin (4).
4. Attach cable hook into large hole in winch assembly bracket (11) and raise wing.
5. Install transport lock pin before moving unit.

BW240HD SHREDDER KIT (OPTIONAL)
(THIS KIT DOES NOT FIT BW240)

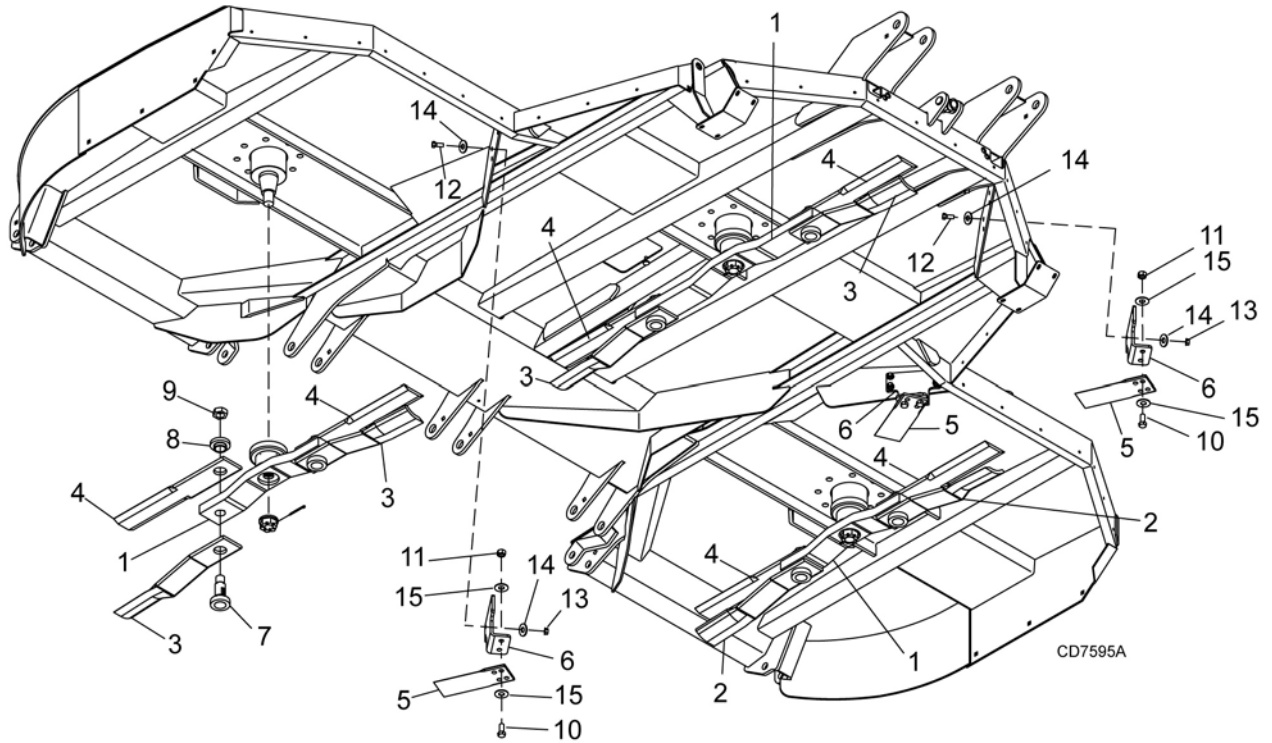

REF	PART	QTY	DESCRIPTION	REF	PART	QTY	DESCRIPTION
A	1032966	1	BW240HD Shredder kit, complete	8	39127	6	Bushing
1	1032967	3	Crossbar	9	39128	6	Jam nut, 1-1/4
2	39002KT	2	Blade, .5 x 4 x 22.5 CW formed	10	4548 *	6	5/8 NC x 1-3/4 HHCS GR5
3	39003KT	4	Blade, .5 x 4 x 22.5 CCW formed	11	6239 *	6	5/8 NC Lock nut
4	1017128KT	6	Blade, .5 x 4 x 22.5 flat	12	3379 *	12	1/2 NC x 1-1/2 HHCS GR5
5	39089	3	Blade, .38 x 4 x 11.13 double edge	13	11900 *	12	1/2 NC Flange lock nut
6	1014164	2	Mounting bracket, bent	14	57816	24	1/2 Hardened flat washer
7	39069	6	Blade pin	15	57817	12	5/8 Hardened flat washer

* Standard hardware, obtain locally
 HHCS Hex Head Cap Screw

76 Parts

(Rev. 11/13/2012)
 MAN0763 (10/10/2008)

BOLT TORQUE CHART

Always tighten hardware to these values unless a different torque value or tightening procedure is listed for a specific application.

Fasteners must always be replaced with the same grade as specified in the manual parts list.

Always use the proper tool for tightening hardware: SAE for SAE hardware and Metric for metric hardware.

Make sure fastener threads are clean and you start thread engagement properly.

All torque values are given to specifications used on hardware defined by SAE J1701 MAR 99 & J1701M JUL 96.

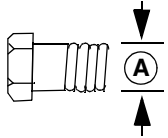

SAE SERIES TORQUE CHART



SAE Grade 2
(No Dashes)

SAE Bolt Head Identification



SAE Grade 5
(3 Radial Dashes)



SAE Grade 8
(6 Radial Dashes)

Ⓐ Diameter (Inches)	Wrench Size	MARKING ON HEAD					
		SAE 2		SAE 5		SAE 8	
		lbs-ft	N-m	lbs-ft	N-m	lbs-ft	N-m
1/4"	7/16"	6	8	10	13	14	18
5/16"	1/2"	12	17	19	26	27	37
3/8"	9/16"	23	31	35	47	49	67
7/16"	5/8"	36	48	55	75	78	106
1/2"	3/4"	55	75	85	115	120	163
9/16"	13/16"	78	106	121	164	171	232
5/8"	15/16"	110	149	170	230	240	325
3/4"	1-1/8"	192	261	297	403	420	569
7/8"	1-5/16"	306	416	474	642	669	907
1"	1-1/2"	467	634	722	979	1020	1383

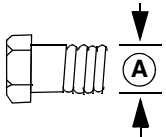

METRIC SERIES TORQUE CHART



Metric
Grade 8.8

Metric Bolt Head Identification



Metric
Grade 10.9

Ⓐ Diameter & Thread Pitch (Millimeters)	Wrench Size	COARSE THREAD				FINE THREAD				Ⓐ Diameter & Thread Pitch (Millimeters)
		MARKING ON HEAD								
		Metric 8.8		Metric 10.9		Metric 8.8		Metric 10.9		
		N-m	lbs-ft	N-m	lbs-ft	N-m	lbs-ft	N-m	lbs-ft	
6 x 1.0	10 mm	8	6	11	8	8	6	11	8	6 x 1.0
8 x 1.25	13 mm	20	15	27	20	21	16	29	22	8 x 1.0
10 x 1.5	16 mm	39	29	54	40	41	30	57	42	10 x 1.25
12 x 1.75	18 mm	68	50	94	70	75	55	103	76	12 x 1.25
14 x 2.0	21 mm	109	80	151	111	118	87	163	120	14 x 1.5
16 x 2.0	24 mm	169	125	234	173	181	133	250	184	16 x 1.5
18 x 2.5	27 mm	234	172	323	239	263	194	363	268	18 x 1.5
20 x 2.5	30 mm	330	244	457	337	367	270	507	374	20 x 1.5
22 x 2.5	34 mm	451	332	623	460	495	365	684	505	22 x 1.5
24 x 3.0	36 mm	571	421	790	583	623	459	861	635	24 x 2.0
30 x 3.0	46 mm	1175	867	1626	1199	1258	928	1740	1283	30 x 2.0

Typical Washer Installations

Bolt

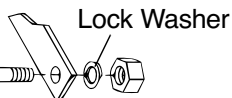

Flat Washer

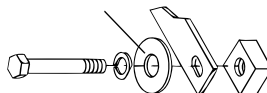

8/9/00

BOLT SIZE CHART

NOTE: Chart shows bolt thread sizes and corresponding head (wrench) sizes for standard SAE and metric bolts.

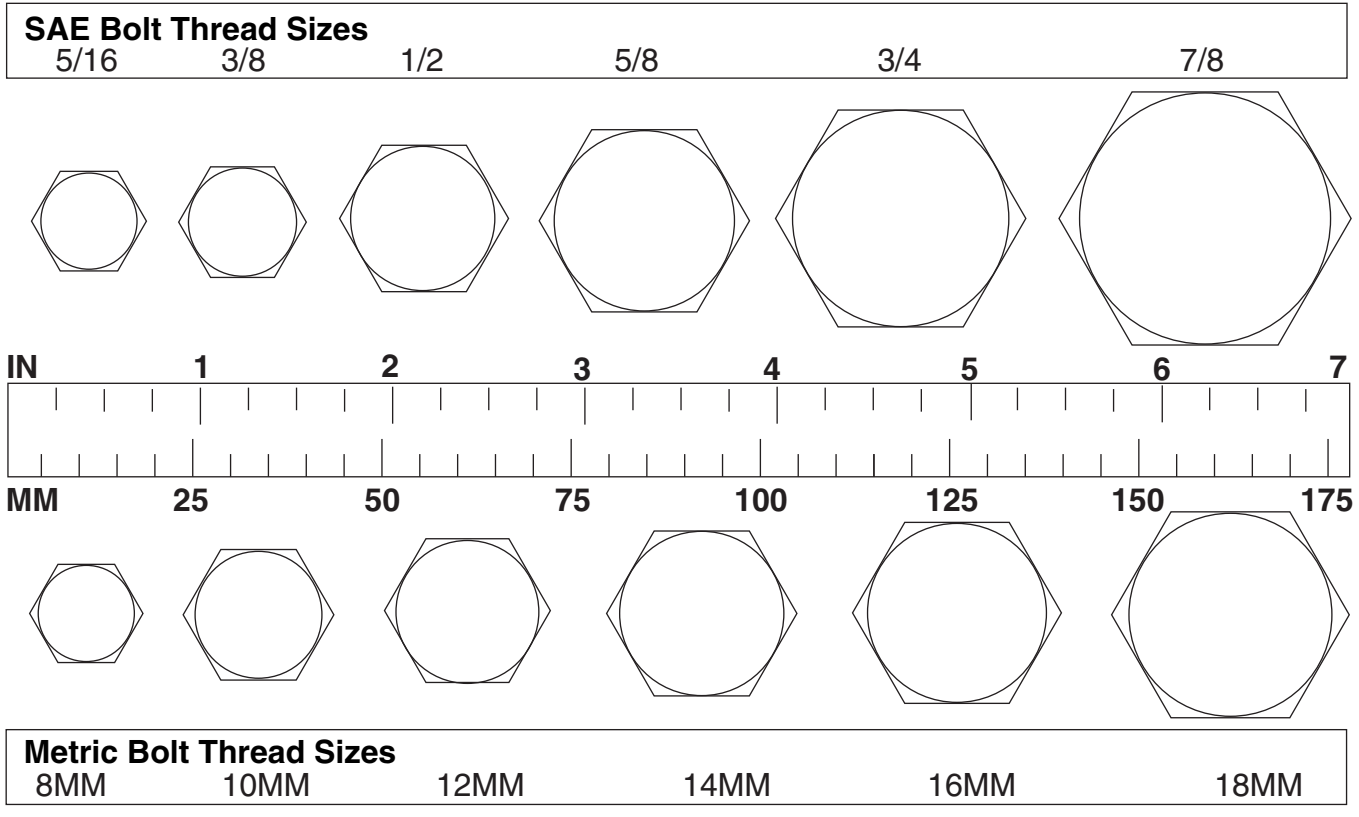

ABBREVIATIONS

AG	Agriculture	MPa.....	Mega Pascal
ASABE.....	American Society of Agricultural & Biological Engineers (formerly ASAE)	N.....	Newton
ASAE	American Society of Agricultural Engineers	NC	National Coarse
ATF	Automatic Transmission Fluid	NF	National Fine
BSPP	British Standard Pipe Parallel	NPSM.....	National Pipe Straight Mechanical
BSPTM	British Standard Pipe Tapered Male	NPT	National Pipe Tapered
CV.....	Constant Velocity	NPT SWF	National Pipe Tapered Swivel Female
CCW	Counter-Clockwise	ORB.....	O-Ring Boss - Male
CW.....	Clockwise	P.....	Pitch
F	Female	PBY	Power-Beyond
FT	Full Thread	psi.....	Pounds per Square Inch
GA	Gauge	PTO.....	Power Take Off
GR (5, etc.)	Grade (5, etc.)	QD.....	Quick Disconnect
HHCS	Hex Head Cap Screw	RH.....	Right Hand
HT.....	Heat-Treated	ROPS	Roll-Over Protective Structure
JIC	Joint Industry Council 37° Degree Flare	RPM	Revolutions Per Minute
LH.....	Left Hand	RT	Right
LT.....	Left	SAE	Society of Automotive Engineers
m.....	Meter	UNC	Unified Coarse
mm.....	Millimeter	UNF.....	Unified Fine
M.....	Male	UNS.....	Unified Special

INDEX

ADJUSTMENTS

- Cutting Height 15
- Slip Clutch 23

ASSEMBLY

- Dealer Set-Up Instructions 34
- Fill Gearboxes 40
- Optional Equipment 41

DEALER CHECK LIST

- Check Lists
 - Delivery (Dealer's Responsibility) 47
 - Pre-Delivery (Dealer's Responsibility) 47

DEALER SERVICE

- Crossbar
 - Installation 32
 - Removal 31
- Gearbox Maintenance
 - Seal Installation 26
 - Seal Replacement 26
 - Horizontal Shaft Replacement 27
 - Vertical Shaft Replacement 27
- Gearbox Repair
 - Assembly 27
 - Disassembly 27
 - Reinstallation 28
 - Removal 27
- Service Tires Safely 33
- Splitter Gearbox Repair
 - Assembly 29
 - Disassembly 29
 - Gearbox Inspection 30
 - Gearbox Installation 30
 - Removal 29
- Universal Joint
 - Assembly 33
 - Disassembly 32
 - Repair 32

GENERAL

- Abbreviations 78
- Bolt Size Chart 78
- Bolt Torque Chart 77
- General Information 4
- Introduction 2
- Obtaining Replacement Manuals 2
- Product Registration 2
- Specifications 4
- Table of Contents 3
- Warranty
 - Product 80

Replacement Parts 81

OPERATION

- Connecting Cutter to Tractor 14
- Cutting Height Adjustment 15
- CV Driveline Turning Limits 15
- Hydraulic Connection 15
- Interference Check 15
- Cutter Operation 16
- Mowing Tips 17
- Shredding 17
- Pre-Operation Check List (Owner's Responsibility) 18
- Storage 18
- Tractor Operation 16
- Transporting 17
 - Lock-Up 17
 - Center Section 18
 - Wing 17

OWNER SERVICE

- Blades
 - Installation 22
 - Removal 22
 - Sharpening 23
- Blocking Method 21
- Cleaning 24
- Lubrication
 - Driveline 21
 - Gearbox 21
 - Lubrication Points Diagram 21
 - Seasonal 22
- Service Tires Safely 24
- Shielding Repair 24
- Slip Clutch Adjustment 23

PARTS

- Parts Index 49

SAFETY

- Blocking Method 20
- Check Lists
 - Delivery Check List (Dealer's Responsibility) 47
 - Pre-Delivery Check List (Dealer's Responsibility) 47
 - Pre-Operation Check List (Owner's Responsibility) 18
- Free Mower Safety Video Order Form 5, 6
- Safety & Instructional Decals 11, 12, 13
- Safety Rules 7, 8, 9, 10
- Safety Symbols Explained 2

TROUBLESHOOTING 25



WARRANTY

All Models Except Mow'n Machine™ Zero-Turn Mowers

Please Enter Information Below and Save for Future Reference.

Date Purchased: _____ From (Dealer): _____

Model Number: _____ Serial Number: _____

Woods Equipment Company ("WOODS") warrants this product to be free from defect in material and workmanship. Except as otherwise set forth below, the duration of this Warranty shall be for TWELVE (12) MONTHS COMMENCING ON THE DATE OF DELIVERY OF THE PRODUCT TO THE ORIGINAL PURCHASER.

All current model loaders and backhoes are warranted for two (2) years from the date of delivery to the original purchaser.

The warranty periods for specific parts or conditions are listed below:

Part or Condition Warranted	Model Number	Duration (from date of delivery to the original purchaser)
	All units invoiced after 4/30/2012	
Gearbox components	BB48X, BB60X, BB72X, BB84X, BB600X, BB720X, BB840X, BB6000X, BB7200X, BB8400X, DS1260, DSO1260, DS1440, TS1680,	6 years
	BW15LH, BW126X, BW180X, BW126XHD, BW180XHD, BW1260X, BW1800X,	
	BW240X, BW240XHD, BW1620X, BW2400X	
	PHD25, PHD35, PHD65, PHD95, DS96, DS120, RCC42, RD990X, PRD6000, PRD7200, PRD8400, S15CD, S20CD, S22CD, S25CD, S27CD, S30CD, TC/R74, TC/R68, TC/R60, TBW144, TBW180, TBW204, TSG50, S12ED, S15ED, S18ED, S20ED	3 years (1 year if used in rental or commercial applications)
RDC54, RD60, RD72, TBW150C, TS/R60, TS/R52, TS/R44, HC48, HC54, HC60, HC72		
Blade spindles	RD990X, PRD6000, PRD7200, PRD8400, TBW144, TBW180, TBW204	3 years
Rust-through	BB600, BB720, BB840, BB6000, BB7200, BB8400, BW126X, BW180X, BW126XHD, BW180XHD, BW1260X, BW1800X, BW240, BW240HD, DS1260, DSO1260, DS1440, TS1680	10 years

Under no circumstances will this Warranty apply in the event that the product, in the good faith opinion of WOODS, has been subjected to improper operation, improper maintenance, misuse, or an accident. This Warranty does not apply in the event that the product has been materially modified or repaired by someone other than WOODS, a WOODS authorized dealer or distributor, and/or a WOODS authorized service center. This Warranty does not cover normal wear or tear, or normal maintenance items. This Warranty also does not cover repairs made with parts other than those obtainable through WOODS.

This Warranty is extended solely to the original purchaser of the product. Should the original purchaser sell or otherwise transfer this product to a third party, this Warranty does not transfer to the third party purchaser in any way. There are no third party beneficiaries of this Warranty.

WOODS makes no warranty, express or implied, with respect to engines, batteries, tires or other parts or accessories not manufactured by WOODS. Warranties for these items, if any, are provided separately by their respective manufacturers.

WOODS' obligation under this Warranty is limited to, at WOODS' option, the repair or replacement, free of charge, of the product if WOODS, in its sole discretion, deems it to be defective or in noncompliance with this Warranty. **The product must be returned to WOODS with proof of purchase within thirty (30) days after such defect or noncompliance is discovered or should have been discovered, routed through the dealer and distributor from whom the purchase was made, transportation charges prepaid.** WOODS shall complete such repair or replacement within a reasonable time after WOODS receives the product. **THERE ARE NO OTHER REMEDIES UNDER THIS WARRANTY. THE REMEDY OF REPAIR OR REPLACEMENT IS THE SOLE AND EXCLUSIVE REMEDY UNDER THIS WARRANTY.**

THERE ARE NO WARRANTIES WHICH EXTEND BEYOND THE DESCRIPTION ON THE FACE OF THIS WARRANTY. WOODS MAKES NO OTHER WARRANTY, EXPRESS OR IMPLIED, AND WOODS SPECIFICALLY DISCLAIMS ANY IMPLIED WARRANTY OF MERCHANTABILITY AND/OR ANY IMPLIED WARRANTY OF FITNESS FOR A PARTICULAR PURPOSE.

WOODS shall not be liable for any incidental or consequential losses, damages or expenses, arising directly or indirectly from the product, whether such claim is based upon breach of contract, breach of warranty, negligence, strict liability in tort or any other legal theory. Without limiting the generality of the foregoing, Woods specifically disclaims any damages relating to (i) lost profits, business, revenues or goodwill; (ii) loss of crops; (iii) loss because of delay in harvesting; (iv) any expense or loss incurred for labor, supplies, substitute machinery or rental; or (v) any other type of damage to property or economic loss.

This Warranty is subject to any existing conditions of supply which may directly affect WOODS' ability to obtain materials or manufacture replacement parts.

No agent, representative, dealer, distributor, serviceperson, salesperson, or employee of any company, including without limitation, WOODS, its authorized dealers, distributors, and service centers, is authorized to alter, modify, or enlarge this Warranty. Answers to any questions regarding warranty service and locations may be obtained by contacting:

Woods Equipment

A Blount International Company

2606 South Illinois Route 2
Post Office Box 1000
Oregon, Illinois 61061 USA

800-319-6637 tel
800-399-6637 fax
woodsequipment.com



ALITEC™
BMP®
CENTRAL FABRICATORS®
GANNON®
GILL®
WAIN-ROY®
WOODS®



WARRANTY

(Replacement Parts For All Models Except Mow'n Machine™
Zero-Turn Mowers and Woods Boundary™ Utility Vehicles)

Woods Equipment Company ("WOODS") warrants this product to be free from defect in material and workmanship for a period of ninety (90) days from the date of delivery of the product to the original purchaser with the exception of V-belts, which will be free of defect in material and workmanship for a period of 12 months.

Under no circumstances will this Warranty apply in the event that the product, in the good faith opinion of WOODS, has been subjected to improper operation, improper maintenance, misuse, or an accident. This Warranty does not cover normal wear or tear, or normal maintenance items.

This Warranty is extended solely to the original purchaser of the product. Should the original purchaser sell or otherwise transfer this product to a third party, this Warranty does not transfer to the third party purchaser in any way. There are no third party beneficiaries of this Warranty.

WOODS' obligation under this Warranty is limited to, at WOODS' option, the repair or replacement, free of charge, of the product if WOODS, in its sole discretion, deems it to be defective or in noncompliance with this Warranty. **The product must be returned to WOODS with proof of purchase within thirty (30) days after such defect or noncompliance is discovered or should have been discovered, routed through the dealer and distributor from whom the purchase was made, transportation charges prepaid.** WOODS shall complete such repair or replacement within a reasonable time after WOODS receives the product. THERE ARE NO OTHER REMEDIES UNDER THIS WARRANTY. THE REMEDY OF REPAIR OR REPLACEMENT IS THE SOLE AND EXCLUSIVE REMEDY UNDER THIS WARRANTY.

THERE ARE NO WARRANTIES WHICH EXTEND BEYOND THE DESCRIPTION ON THE FACE OF THIS WARRANTY. WOODS MAKES NO OTHER WARRANTY, EXPRESS OR IMPLIED, AND WOODS SPECIFICALLY DISCLAIMS ANY IMPLIED WARRANTY OF MERCHANTABILITY AND/OR ANY IMPLIED WARRANTY OF FITNESS FOR A PARTICULAR PURPOSE.

WOODS shall not be liable for any incidental or consequential losses, damages or expenses, arising directly or indirectly from the product, whether such claim is based upon breach of contract, breach of warranty, negligence, strict liability in tort or any other legal theory. Without limiting the generality of the foregoing, Woods specifically disclaims any damages relating to (i) lost profits, business, revenues or goodwill; (ii) loss of crops; (iii) loss because of delay in harvesting; (iv) any expense or loss incurred for labor, supplies, substitute machinery or rental; or (v) any other type of damage to property or economic loss.

This Warranty is subject to any existing conditions of supply which may directly affect WOODS' ability to obtain materials or manufacture replacement parts.

No agent, representative, dealer, distributor, service person, salesperson, or employee of any company, including without limitation, WOODS, its authorized dealers, distributors, and service centers, is authorized to alter, modify, or enlarge this Warranty.

Answers to any questions regarding warranty service and locations may be obtained by contacting:

ALITEC™
BMP®
CENTRAL FABRICATORS®
GANNON®
GILL®
WAIN-ROY®
WOODS®

WOODS®
Woods Equipment Company

Woods Equipment
A Blount International Company
2606 South Illinois Route 2
Post Office Box 1000
Oregon, Illinois 61061
800-319-6637 tel
800-399-6637 fax
woodsequipment.com

PART NO.
MAN0763

Woods Equipment

A Blount International Company

2606 South Illinois Route 2
Post Office Box 1000
Oregon, Illinois 61061

800-319-6637 tel
800-399-6637 fax
woodsequipment.com



Woods Equipment Company