

WOODS BATWING® ROTARY CUTTER

BW15LH

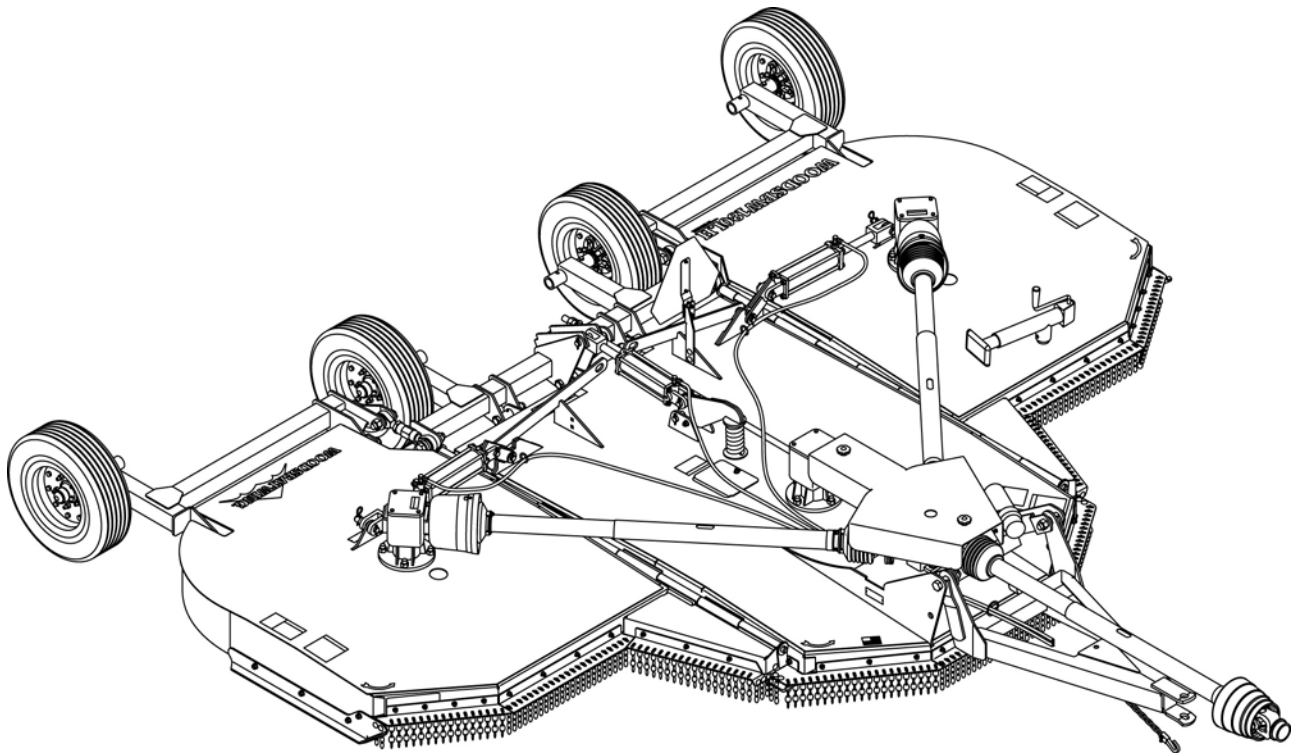

MAN0810

(Rev. 9/11/2013)

WOODS®
Woods Equipment Company

OPERATOR'S MANUAL

TO THE DEALER:

Assembly and proper installation of this product is the responsibility of the Woods® dealer. Read manual instructions and safety rules. Make sure all items on the Dealer's Pre-Delivery and Delivery Check Lists in the Operator's Manual are completed before releasing equipment to the owner.

The dealer must complete the online Product Registration form at the Woods Dealer Website which certifies that all Dealer Check List items have been completed. Dealers can register all Woods product at dealer.WoodsEquipment.com under Product Registration.

Failure to register the product does not diminish customer's warranty rights.

TO THE OWNER:

Read this manual before operating your Woods equipment. The information presented will prepare you to do a better and safer job. Keep this manual handy for ready reference. Require all operators to read this manual carefully and become acquainted with all adjustment and operating procedures before attempting to operate. Replacement manuals can be obtained from your dealer. To locate your nearest dealer, check the Dealer Locator at www.WoodsEquipment.com, or in the United States and Canada call 1-800-319-6637.

The equipment you have purchased has been carefully engineered and manufactured to provide dependable and satisfactory use. Like all mechanical products, it will require cleaning and upkeep. Lubricate the unit as specified. Observe all safety information in this manual and safety decals on the equipment.

For service, your authorized Woods dealer has trained mechanics, genuine Woods service parts, and the necessary tools and equipment to handle all your needs.

Use only genuine Woods service parts. Substitute parts will void the warranty and may not meet standards required for safe and satisfactory operation. Record the model number and serial number of your equipment in the spaces provided:

Model: _____ **Date of Purchase:** _____

Serial Number: (see Safety Decal section for location) _____

Provide this information to your dealer to obtain correct repair parts.

Throughout this manual, the term **NOTICE** is used to indicate that failure to observe can cause damage to equipment. The terms **CAUTION**, **WARNING**, and **DANGER** are used in conjunction with the Safety-Alert Symbol (a triangle with an exclamation mark) to indicate the degree of hazard for items of personal safety.



This is the safety alert symbol. It is used to alert you to potential physical injury hazards. Obey all safety messages that follow this symbol to avoid possible injury or death.



Indicates a hazardous situation that, if not avoided, will result in death or serious injury.



Indicates a hazardous situation that, if not avoided, could result in death or serious injury.



Indicates a hazardous situation that, if not avoided, could result in minor or moderate injury.

**IMPORTANT
or NOTICE**

Is used to address practices not related to physical injury.

NOTE

Indicates helpful information.

WOODS
Woods Equipment Company

ALITEC™
BMP®
CENTRAL FABRICATORS®
GANNON®
GILL®
WAIN-ROY®
WOODS®

2 Introduction

Gen'1 (Rev. 3/28/2012)

TABLE OF CONTENTS

INTRODUCTION	2
SPECIFICATIONS	4
GENERAL INFORMATION	4
SAFETY VIDEO ORDER FORM	5
SAFETY RULES	7
SAFETY DECALS	11
OPERATION	14
OWNER SERVICE	19
TROUBLESHOOTING	24
DEALER SERVICE	25
ASSEMBLY INSTRUCTIONS	34
DEALER CHECK LISTS	43
INDEX TO PARTS LISTS	45
BOLT TORQUE CHART	68
BOLT SIZE CHART & ABBREVIATIONS	69
INDEX	70
PRODUCT WARRANTY	INSIDE BACK COVER
REPLACEMENT PARTS WARRANTY	BACK COVER



¡LEA EL INSTRUCTIVO!

Si no lee Ingles, pida ayuda a alguien que si lo lea para que le traduzca las medidas de seguridad.

NOTICE:

If you would like to receive a free Spanish language translation of the Safety Rules section of this manual, plus a set of Spanish language safety decals, please contact your local Woods dealer.

AVISO:

Si desea recibir una traducción al español gratuita de la sección Reglas de seguridad de este manual y un juego de etiquetas de seguridad en español, por favor comuníquese con su concesionario local de Woods.



This Operator's Manual should be regarded as part of the machine. Suppliers of both new and second-hand machines must make sure that this manual is provided with the machine.

SPECIFICATIONS

BW15LH

Cutting Height (Varies with tire selection)	1" - 12"
Cutting Width	180" (15')
Overall Width	190"
Transport Width	96"
Tractor HP	40-90
Tractor PTO rpm	540
Blade Speed (Feet per minute)	15, 270
Blade Spindle	3
Blade Overlap	6"
Number of Blades	6
Blade Rotation	Left Spindle: CW; Right & Center Spindles: CCW
Wing Driveline	Cat 3
CV	Cat 4
Side Frame Thickness	7 ga. (.18")
Weight (approximate lbs.)	3200
Wheel Size	15" Rims or 21" OD Solid Tires or 24" Airplane Tires
Torsion Protection	Slip Clutch

GENERAL INFORMATION

 **WARNING**

■ Some illustrations in this manual show the equipment with safety shields removed to provide a better view. This equipment should never be operated with any necessary safety shielding removed.

The purpose of this manual is to assist you in operating and maintaining your cutter. Read it carefully. It furnishes information and instructions that will help you achieve years of dependable performance. These instructions have been compiled from extensive field experience and engineering data. Some information may be general in nature due to unknown and varying

operating conditions. However, through experience and these instructions, you should be able to develop procedures suitable to your particular situation.

The illustrations and data used in this manual were current at the time of printing but, due to possible inline production changes, your machine may vary slightly in detail. We reserve the right to redesign and change the machines as may be necessary without notification.

Throughout this manual, references are made to right and left directions. These are determined by standing behind the equipment facing the direction of forward travel. Blade rotation is clockwise (left wing) and counterclockwise (right wing and center section) as viewed from the top of the cutter.

BE SAFE!

BE ALERT!

BE ALIVE!

BE TRAINED

Before Operating Mowers!



ASSOCIATION OF
EQUIPMENT
MANUFACTURERS

*Safety Training
Does Make a Difference.*

Free Mower Safety Video

Fill out and return the order form and we will send you a FREE VHS or DVD video outlining ***Industrial and Agricultural Mower Safety Practices***. The 22 minute video, developed in cooperation with AEM (Association of Equipment Manufacturers), reinforces the proper procedures to follow while operating your mowing equipment. The video does not replace the information contained in the Operator's Manual, so please review this manual thoroughly before operating your new mowing equipment.

Also, available from the Association of Equipment Manufacturers:

A large variety of training materials (ideal for groups) are available for a nominal charge from AEM. Following is a partial list:

- **Training Package for Rotary Mowers/Cutters-English**
Contains: DVD & VHS (English)
 Guidebook for Rotary Mowers/Cutters (English)
 AEM Industrial/Agricultural Mower Safety Manual (English)
 AEM Agricultural Tractor Safety Manual (English)

- **Training Package for Rotary Mowers/Cutters-English/Spanish**
Contains: DVD & VHS (English/Spanish)
 Guidebook for Rotary Mowers/Cutters (English/Spanish)
 AEM Industrial/Agricultural Mower Safety Manual (English/Spanish)
 AEM Agricultural Tractor Safety Manual (English/Spanish)

AEM training packages are available through:

AEM at: www.aem.org

or

Universal Lithographers, Inc.

Email: aem@ulilitho.com

800-369-2310 tel

866-541-1668 fax



Free Mower/Cutter Safety Video Order Form

✓ (Select one)

Please send me

VHS Format - VHS01052 Safety Video

DVD Format - DVD01052 Safety Video

Name: _____ Phone: _____

Address: _____

Mower/Cutter Model: _____ Serial #: _____

Send to: ATTENTION: DEALER SERVICES
 WOODS EQUIPMENT COMPANY
 PO BOX 1000
 OREGON IL 61061-1000
 USA

SAFETY RULES



ATTENTION! BECOME ALERT! YOUR SAFETY IS INVOLVED!



Safety is a primary concern in the design and manufacture of our products. Unfortunately, our efforts to provide safe equipment can be wiped out by an operator's single careless act.

In addition to the design and configuration of equipment, hazard control and accident prevention are dependent upon the awareness, concern, judgement, and proper training of personnel involved in the operation, transport, maintenance, and storage of equipment.

It has been said, "The best safety device is an informed, careful operator." We ask you to be that kind of operator.

INSTALLATION

■ Hydraulics must be connected as instructed in this manual. Do not substitute parts, modify, or connect in any other way.

TRAINING

■ Safety instructions are important! Read all attachment and power unit manuals; follow all safety rules and safety decal information. (Replacement manuals and safety decals are available from your dealer. To locate your nearest dealer, check the Dealer Locator at www.WoodsEquipment.com, or in the United States and Canada call 1-800-319-6637.) Failure to follow instructions or safety rules can result in serious injury or death.

■ If you do not understand any part of this manual and need assistance, see your dealer.

■ Know your controls and how to stop engine and attachment quickly in an emergency.

■ Operators must be instructed in and be capable of the safe operation of the equipment, its attachments, and all controls. Do not allow anyone to operate this equipment without proper instructions.

■ Keep hands and body away from pressurized lines. Use paper or cardboard, not hands or other body parts to check for leaks. Wear safety goggles. Hydraulic fluid under pressure can easily penetrate skin and will cause serious injury or death.

■ Make sure that all operating and service personnel know that if hydraulic fluid penetrates skin, it must be surgically removed as soon as possible by a doctor familiar with this form of injury or gangrene, serious injury, or death will result. CON-

TACT A PHYSICIAN IMMEDIATELY IF FLUID ENTERS SKIN OR EYES. DO NOT DELAY.

■ Never allow children or untrained persons to operate equipment.

PREPARATION

■ Check that all hardware is properly installed. Always tighten to torque chart specifications unless instructed otherwise in this manual.

■ Air in hydraulic systems can cause erratic operation and allows loads or equipment components to drop unexpectedly. When connecting equipment or hoses or performing any hydraulic maintenance, purge any air in hydraulic system by operating all hydraulic functions several times. Do this before putting into service or allowing anyone to approach the equipment.

■ Make sure all hydraulic hoses, fittings, and valves are in good condition and not leaking before starting power unit or using equipment. Check and route hoses carefully to prevent damage. Hoses must not be twisted, bent sharply, kinked, frayed, pinched, or come into contact with any moving parts. Operate moveable components through full operational range to check clearances. Replace any damaged hoses immediately.

■ After connecting hoses, check that all control lever positions function as instructed in the Operator's Manual. Do not put into service until control lever and equipment movements are correct.

■ Set tractor hydraulic relief valve at 2500 psi (170 bars) (17,000 kPa) to prevent injury and equipment damage due to hydraulic system failure.

■ Your dealer can supply original equipment hydraulic accessories and repair parts. Substitute parts may not meet original equipment specifications and may be dangerous.

■ Always wear relatively tight and belted clothing to avoid getting caught in moving parts. Wear sturdy, rough-soled work shoes and protective equipment for eyes, hair, hands, hearing, and head; and respirator or filter mask where appropriate.

■ Make sure attachment is properly secured, adjusted, and in good operating condition.

■ Make sure spring-activated locking pin or collar slides freely and is seated firmly in tractor PTO spline groove.

(Safety Rules continued on next page)

SAFETY RULES



ATTENTION! BECOME ALERT! YOUR SAFETY IS INVOLVED!



(Safety Rules continued from previous page)

■ Before starting power unit, check all equipment driveline guards for damage. Replace any damaged guards. Make sure all guards rotate freely on all drivelines. If guards do not rotate freely on drivelines, repair and replace bearings before putting equipment into service.

■ Power unit must be equipped with ROPS or ROPS cab and seat belt. Keep seat belt securely fastened. Falling off power unit can result in death from being run over or crushed. Keep foldable ROPS system in “locked up” position at all times.

■ Remove accumulated debris from this equipment, power unit, and engine to avoid fire hazard.

■ Make sure all safety decals are installed. Replace if damaged. (See Safety Decals section for location.)

■ Make sure shields and guards are properly installed and in good condition. Replace if damaged.

■ Do not put this equipment into service unless all side skids are properly installed and in good condition. Replace if damaged.

■ A minimum 20% of tractor and equipment weight must be on the tractor front wheels when attachments are in transport position. Without this weight, front tractor wheels could raise up resulting in loss of steering. The weight may be attained with front wheel weights, ballast in tires or front tractor weights. Weigh the tractor and equipment. Do not estimate.

■ Inspect and clear area of stones, branches, or other hard objects that might be thrown, causing injury or damage.

■ Connect PTO driveline directly to power unit PTO shaft. Never use adapter sleeves or adapter shafts. Adapters can cause driveline failures due to incorrect spline or incorrect operating length and can result in personal injury or death.

TRANSPORTATION

■ Power unit must be equipped with ROPS or ROPS cab and seat belt. Keep seat belt securely fastened. Falling off power unit can result in death from being run over or crushed. Keep foldable ROPS system in “locked up” position at all times.

■ Always raise unit and install transport locks before transporting. Leak down or failure of mechanical or hydraulic system can cause equipment to drop.

■ Always attach safety chain to tractor drawbar when transporting unit.

■ Always comply with all state and local lighting and marking requirements.

■ Never allow riders on power unit or attachment.

■ Do not operate PTO during transport.

■ Do not operate or transport on steep slopes.

■ Do not operate or transport equipment while under the influence of alcohol or drugs.

■ The maximum transport speed for towed and semi-mounted machines is 20 mph (32 km/h). Regardless of the maximum speed capability of the towing tractor, do not exceed the implement’s maximum transport speed. Doing so could result in:

- Loss of control of the implement and tractor
- Reduced or no ability to stop during braking
- Implement tire failure
- Damage to the implement or its components.

■ Use additional caution and reduce speed when under adverse surface conditions, turning, or on inclines.

■ Never tow this implement with a motor vehicle.

OPERATION

■ Do not allow bystanders in the area when operating, attaching, removing, assembling, or servicing equipment.

■ Never walk, stand, or place yourself or others under a raised wing or in the path of a lowering wing. Hydraulic system leak-down, hydraulic system failures, mechanical failures, or movement of control levers can cause wings to drop unexpectedly and cause severe injury or death.

■ Full chain or rubber shielding must be installed when operating in populated areas or other areas where thrown objects could injure people or damage property.

- If this machine is not equipped with full chain or rubber shielding, operation must be stopped when anyone comes within 300 feet (92 m).
- This shielding is designed to reduce the risk of thrown objects. The mower deck and protective devices cannot prevent all objects from escaping the blade enclosure in every mowing condition. It is possible for objects to ricochet and escape, traveling as much as 300 feet (92 m).

■ Never direct discharge toward people, animals, or property.

(Safety Rules continued on next page)



SAFETY RULES

ATTENTION! BECOME ALERT! YOUR SAFETY IS INVOLVED!



(Safety Rules continued from previous page)

- Do not operate or transport equipment while under the influence of alcohol or drugs.
- Operate only in daylight or good artificial light.
- Keep hands, feet, hair, and clothing away from equipment while engine is running. Stay clear of all moving parts.
- Always comply with all state and local lighting and marking requirements.
- Never allow riders on power unit or attachment.
- Power unit must be equipped with ROPS or ROPS cab and seat belt. Keep seat belt securely fastened. Falling off power unit can result in death from being run over or crushed. Keep foldable ROPS system in “locked up” position at all times.
- Always sit in power unit seat when operating controls or starting engine. Securely fasten seat belt, place transmission in neutral, engage brake, and ensure all other controls are disengaged before starting power unit engine.
- Operate tractor PTO at 540 RPM. Do not exceed.
- Raise or lower wings slowly to prevent personal injury or damage to cutter.
- Look down and to the rear and make sure area is clear before operating in reverse.
- Do not operate or transport on steep slopes.
- Do not stop, start, or change directions suddenly on slopes.
- Watch for hidden hazards on the terrain during operation.
- Stop power unit and equipment immediately upon striking an obstruction. Turn off engine, remove key, inspect, and repair any damage before resuming operation.
- Continuous operation while the clutch is slipping could cause heat build-up resulting in fire. Adjust slip clutch pressure by tightening springs to the dimension shown in the “Owner Service” section. If clutch is set to minimum spring length, replace the friction disks as shown.
- On pull-type or semi-mounted units with optional hydraulic cutting height adjustment, use a single-acting cylinder with a maximum extended length of 28-1/4" (718 mm) from attaching point center to center.

MAINTENANCE

- Before servicing, adjusting, repairing or unplugging, stop tractor engine, place all controls in neutral, set park brake, remove ignition key, and wait for all moving parts to stop.
- Before dismounting power unit or performing any service or maintenance, follow these steps: disengage power to equipment, lower the 3-point hitch and all raised components to the ground, operate valve levers to release any hydraulic pressure, set parking brake, stop engine, remove key, and unfasten seat belt.
- Before working underneath, disconnect driveline from tractor, lower wings to ground, raise cutter, and pin transport bar in raised position. Attach parking jack and lower to ground. Securely block all four corners of center section and each wing with jack-stands. Blocking up prevents the cutter from dropping due to hydraulic leak down, hydraulic system failure, or mechanical component failure.
- Do not modify or alter or permit anyone else to modify or alter the equipment or any of its components in any way.
- Your dealer can supply original equipment hydraulic accessories and repair parts. Substitute parts may not meet original equipment specifications and may be dangerous.
- To prevent contamination during maintenance and storage, clean and then cover hose ends, fittings, and hydraulic ports with tape.
- Do not allow bystanders in the area when operating, attaching, removing, assembling, or servicing equipment.
- Never go underneath equipment (lowered to the ground or raised) unless it is properly blocked and secured. Never place any part of the body underneath equipment or between moveable parts even when the engine has been turned off. Hydraulic system leak down, hydraulic system failures, mechanical failures, or movement of control levers can cause equipment to drop or rotate unexpectedly and cause severe injury or death. Follow Operator's Manual instructions for working underneath and blocking requirements or have work done by a qualified dealer.

(Safety Rules continued on next page)



SAFETY RULES

ATTENTION! BECOME ALERT! YOUR SAFETY IS INVOLVED!



(Safety Rules continued from previous page)

- Keep all persons away from operator control area while performing adjustments, service, or maintenance.
- Make certain all movement of equipment components has stopped before approaching for service.
- Frequently check blades. They should be sharp, free of nicks and cracks, and securely fastened.
- Do not handle blades with bare hands. Careless or improper handling may result in serious injury.
- Your dealer can supply genuine replacement blades. Substitute blades may not meet original equipment specifications and may be dangerous.
- Tighten all bolts, nuts, and screws to torque chart specifications. Check that all cotter pins are installed securely to ensure equipment is in a safe condition before putting unit into service.
- Make sure all safety decals are installed. Replace if damaged. (See Safety Decals section for location.)
- Make sure shields and guards are properly installed and in good condition. Replace if damaged.
- Never perform service or maintenance with engine running.
- Do not disconnect hydraulic lines until machine is securely blocked or placed in lowest position and system pressure is released by operating valve levers.

- Service and maintenance work not covered in OWNER SERVICE must be done by a qualified dealership. Special skills, tools, and safety procedures may be required. Failure to follow these instructions can result in serious injury or death.

- Explosive separation of tire and rim parts can cause serious injury or death. Release all air pressure before loosening bolts on wheel.

STORAGE

- Before disconnecting and storing, follow these instructions:

- Store on level, solid ground.
- Disconnect driveline and secure up off the ground.
- Lower wings to ground.
- Raise cutter center section and pin transport bar in raised position.
- Attach parking jack and raise tongue weight off tractor drawbar.
- Place wedge blocks at front and rear of wheels on center section and each wing to prevent wheel rotation.
- Securely block all four corners of center section and each wing with jackstands.
- Remove hydraulic hoses after tractor is turned off and all system pressure is released by operating valve levers several times.
- Remove safety tow chain.
- Remove retainer pin and high strength drawbar pin.

- Keep children and bystanders away from storage area.





SAFETY & INSTRUCTIONAL DECALS

ATTENTION! BECOME ALERT! YOUR SAFETY IS INVOLVED!
Replace Immediately If Damaged!



Model#
Serial#
(BAR CODE)
WOODS Woods Equipment Company Oregon, Illinois 61061 USA

1 - SERIAL NUMBER PLATE

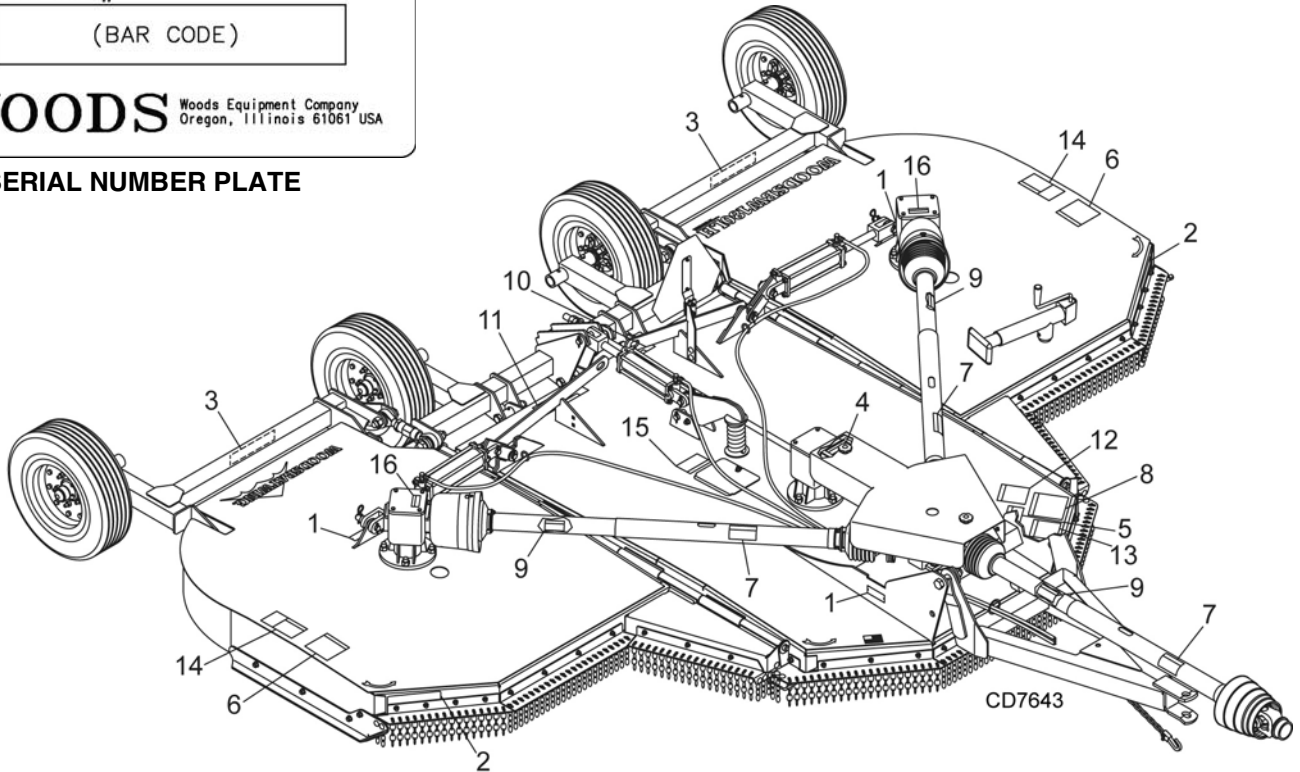

PN 1006348 - Located on Wheel Rims

⚠ WARNING	EXPLOSION HAZARD
RELEASE ALL AIR PRESSURE BEFORE LOOSENING BOLTS. FAILURE TO DO SO COULD RESULT IN SERIOUS INJURY OR DEATH. MAX. SPEED: 20 MPH, MAX. WEIGHT: 4000 LBS., MAX. AIR PRESSURE: 40 PSI.	

BE CAREFUL!

Use a clean, damp cloth to clean safety decals.

Avoid spraying too close to decals when using a pressure washer; high-pressure water can enter through very small scratches or under edges of decals causing them to peel or come off.

Replacement safety decals can be ordered free from your Woods dealer. To locate your nearest dealer, check the Dealer Locator at www.WoodsEquipment.com, or in the United States and Canada call 1-800-319-6637.

2 - FRONT AMBER REFLECTOR
(PN 1002940)

3 - REAR RED REFLECTOR
(PN 57123)

4 - PN 18869

⚠ DANGER
SHIELD MISSING
DO NOT OPERATE - PUT SHIELD ON



SAFETY & INSTRUCTIONAL DECALS

ATTENTION! BECOME ALERT! YOUR SAFETY IS INVOLVED!



Replace Immediately If Damaged!

7 - PN 18864

WARNING

DO NOT EXCEED PTO SPEED OF 540 RPM

PTO speeds higher than 540 RPM can cause equipment failure and personal injury.

18866-D

5 - PN 18866 (540 RPM)

DANGER



ROTATING DRIVELINE CONTACT CAN CAUSE DEATH

KEEP AWAY!

DO NOT OPERATE WITHOUT -

- All driveline guards, tractor and equipment shields in place
- Drivelines securely attached at both ends
- Driveline guards that turn freely on driveline

18864-C

8 - PN 18865

WARNING

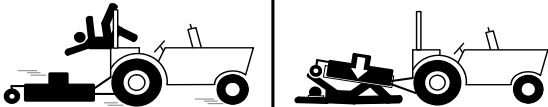

FALLING OFF CAN RESULT IN BEING RUN OVER.

- Tractor must be equipped with ROPS (or ROPS CAB) and seat belt. Keep foldable ROPS systems in "locked up" position at all times.
- Buckle Up! Keep seat belt securely fastened.
- Allow no riders.

RAISED EQUIPMENT CAN DROP AND CRUSH.

- Before working underneath, follow all instructions and safety rules in operator's manual and securely block up all corners of equipment with jack stands.
- Securely blocking prevents equipment dropping from hydraulic leak-down, hydraulic system failures or mechanical component failures.

FALLING OFF OR FAILING TO BLOCK SECURELY CAN RESULT IN SERIOUS INJURY OR DEATH.

18865-C

6 - PN 15503

DANGER



ROTATING BLADES AND THROWN OBJECTS

- Do not put hands or feet under or into mower when engine is running.
- Before mowing, clear area of objects that may be thrown by blade.
- Keep bystanders away.
- Keep guards in place and in good condition.

BLADE CONTACT OR THROWN OBJECTS CAN CAUSE SERIOUS INJURY OR DEATH.

15503-C

16 - PN 1004114

DANGER

If shaft connection is visible, shield is missing. Replace shield before operating equipment.

1004114

10 - PN 19924

WARNING

HIGH-PRESSURE HYDRAULIC OIL LEAKS CAN PENETRATE SKIN RESULTING IN SERIOUS INJURY, GANGRENE OR DEATH.

- Check for leaks with cardboard; never use hand.
- Before loosening fittings: lower load, release pressure, and be sure oil is cool.
- Consult physician immediately if skin penetration occurs.

19924-B



SAFETY & INSTRUCTIONAL DECALS

ATTENTION! BECOME ALERT! YOUR SAFETY IS INVOLVED!

Replace Immediately If Damaged!

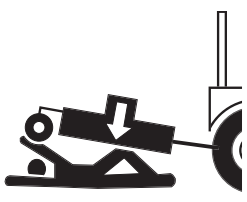
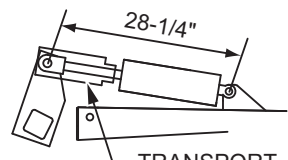

11 - PN 1004991

 <p style="text-align: center; font-size: small;">1004991</p>	<h2 style="margin: 0;">⚠ WARNING</h2> <h3 style="margin: 5px 0 0 0;">RAISED CUTTER CAN DROP AND CRUSH</h3> <ul style="list-style-type: none"> ■ Cutters must be equipped with transport lock. ■ Before working underneath, transport lock must be in the raised position. All corners of cutter must be securely blocked with jack stands. ■ All transport components must be functional, kept in good condition, and stored on equipment. ■ Blocking up prevents cutter dropping from hydraulic leak down, hydraulic system failures, or mechanical component failures. <p style="text-align: center; font-weight: bold; font-size: small;">FAILURE TO FOLLOW INSTRUCTIONS CAN RESULT IN SERIOUS INJURY OR DEATH.</p>	<p style="text-align: center; font-weight: bold; font-size: small;">TRANSPORT LOCK AND CYLINDER REQUIREMENTS</p> <p style="text-align: center; font-size: x-small;">SINGLE-ACTING FULL EXTENSION</p>  <p style="text-align: center; font-size: x-small;">TRANSPORT LOCK</p>
--	--	--

9 - PN 33347

⚠ DANGER



GUARD MISSING. DO NOT OPERATE.

⚠ DANGER



GUARD MISSING. DO NOT OPERATE.

33347E

⚠ DANGER

12 - PN 1003751

⚠ WARNING





CRUSHING AND PINCHING HAZARD

- Be extremely careful handling various parts of the machine. They are heavy and hands, fingers, feet, and other body parts could be crushed or pinched between tractor and implement.
- Operate tractor controls from tractor seat only.
- Do not stand between tractor and implement when tractor is in gear.
- Make sure parking brake is engaged before going between tractor and implement.
- Stand clear of machine while in operation or when it is being raised or lowered.

FAILURE TO FOLLOW THESE INSTRUCTIONS COULD RESULT IN SERIOUS INJURY OR DEATH.

1003751-A

13 - PN 18877

⚠ WARNING



TO AVOID SERIOUS INJURY OR DEATH:

- Read Operator's Manual (available from dealer) and follow all safety precautions.
- Keep all shields in place and in good condition.
- Operate mower from tractor seat only.
- Lower mower, stop engine and remove key before dismounting tractor.
- Allow no children or untrained persons to operate equipment.
- Do not transport towed or semi-mounted units over 20 mph.

FAILURE TO OPERATE SAFELY CAN RESULT IN INJURY OR DEATH.

18877-C

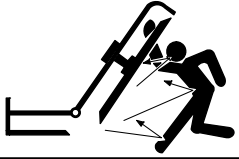
14 - PN 18964

18964-A

⚠ WARNING

RAISED WING EXPOSES BLADE AND INCREASES THROWN OBJECT HAZARDS.

- Only raise for transport. Stop cutter and lock wing(s) up.

RAISED WING CAN FALL AND CRUSH.

- Keep away.
- Lock up with wing transport bars.
- Lower wing(s) after transport and for storage.

FAILURE TO FOLLOW INSTRUCTIONS CAN RESULT IN SERIOUS INJURY OR DEATH.

15 - PN 15502

⚠ WARNING

ROTATING COMPONENTS

Do not operate without cover in place. Look and listen for rotation. Do not open cover until all components have stopped.

CONTACT WITH ROTATING PARTS CAN CAUSE SERIOUS INJURY.

15502-B

OPERATION

The designed and tested safety of this machine depends on it being operated within the limitations as explained in this manual. Be familiar with and follow all safety rules in the manual, on the cutter and on the tractor.

The safe operation of this cutter is the responsibility of the operator, who must be properly trained. The operator should be familiar with the equipment and all safety practices before starting operation. Read the safety information on page 7 through page 13.

Recommended tractor ground speed for most conditions is from 1 to 6 mph.

Always operate tractor PTO at 540 rpm.

! DANGER

■ Full chain or rubber shielding must be installed when operating in populated areas or other areas where thrown objects could injure people or damage property.

- If this machine is not equipped with full chain or rubber shielding, operation must be stopped when anyone comes within 300 feet (92 m).
- This shielding is designed to reduce the risk of thrown objects. The mower deck and protective devices cannot prevent all objects from escaping the blade enclosure in every mowing condition. It is possible for objects to ricochet and escape, traveling as much as 300 feet (92 m).

! WARNING

- Never allow children or untrained persons to operate equipment.
- Do not allow bystanders in the area when operating, attaching, removing, assembling, or servicing equipment.
- Make sure spring-activated locking pin or collar slides freely and is seated firmly in tractor PTO spline groove.

! CAUTION

- Stop power unit and equipment immediately upon striking an obstruction. Turn off engine, remove key, inspect, and repair any damage before resuming operation.
- Always wear relatively tight and belted clothing to avoid getting caught in moving parts. Wear sturdy, rough-soled work shoes and protective

equipment for eyes, hair, hands, hearing, and head; and respirator or filter mask where appropriate.

CONNECTING CUTTER TO TRACTOR

NOTICE

■ For tractors with a 1-3/8" diameter PTO shaft, the horizontal distance from the end of the tractor PTO shaft to the center of drawbar pin should be 14" for 540 rpm cutter. This will minimize joint knock and damage to drive components.

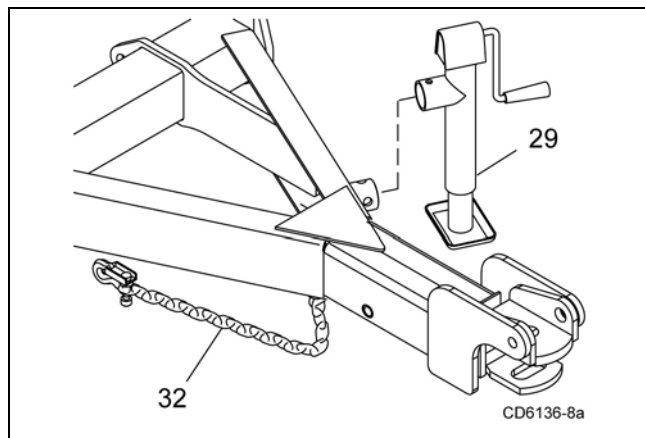

Figure 1. Cutter to Tractor Connection

1. Attach cutter using a 1-1/2" clevis pin and clip.
2. Attach safety tow chain (32) to drawbar support. Leave enough slack for turning (Figure 1).
3. Connect cutter driveline to tractor PTO shaft, making sure the spring-activated lock pin slides freely and is seated in tractor PTO splined groove.
4. Remove parking jack (29) from the tongue and attach it to the storage post on the front of the left wing.

Hydraulic Connection

1. Inspect hydraulic hoses to ensure they are in good condition.
2. Clean the fittings before connecting them to the tractor hydraulic ports.
3. Route the hose through the hose holder at the hitch and be sure the hose can slide freely in the holder. Do not allow hose slack to drag on the ground or become caught on tractor protrusions.
4. Attach the hydraulic hose to the tractor.
5. From the operator position, start tractor and raise and lower deck several times to purge trapped air from the hydraulic cylinder.

Interference Check

1. Be sure that tractor 3-point lift links do not interfere with hydraulic hoses, cutter driveline, or cutter frame.
2. Check for straight-ahead operation and at full turning angles. If there is any interference, remove the lower lift links.
3. Contact between tractor lift links and cutter parts can cause damage, especially when turning.

CV Driveline Turning Limits

NOTICE

■ **You must not exceed a turning angle of 80 degrees at the head of the Constant Velocity driveline or damage will occur.**

1. To check for potential excessive turn angle, disconnect the driveline from tractor.
2. Start engine and turn as far right or left as possible.
3. Shut engine off and try to connect CV driveline to tractor. If it cannot be connected, the turn angle is too severe.
4. Restart engine and straighten angle slightly, shut off engine and try to connect CV driveline to tractor.
5. Repeat the process until the driveline can be connected. The point at which the driveline can be connected is the maximum turn that should be made.

Cutting Height Adjustment



■ **On pull-type or semi-mounted units with optional hydraulic cutting height adjustment, use a single-acting cylinder with a maximum extended length of 28-1/4" (718 mm) from attaching point center to center.**

NOTICE

■ **Avoid ground contact with blades. Striking ground with blades produces one of the most damaging shock loads a cutter can encounter. If this occurs repeatedly, the cutter, driveline, and gearboxes will be damaged.**

Cutting height range is from 1" to 12". A hydraulic cylinder or ratchet jack is available for cutting height adjustment.

When selecting a cutting height, you should consider the area of operation. If the ground is rolling and has mounds the blades could contact, set the cutting height accordingly. The cutting height (blade edge) is approximately 1" above the bottom of the side skid.

Cutting Height (Normal Mowing) - Center Section

1. Position the cutter on a hard level surface and select an approximate cutting height, Example 6".
2. Raise wings and lock them in the UP position.
3. Use any of the optional cutting height mechanisms to raise or lower the center section to obtain a distance of 5" from bottom edge of skid shoe to the ground.
4. Loosen jam nuts on the attitude rod that runs from the wheel yoke to the tongue.
5. Adjust rod in or out until the rear of the cutter is approximately 1/2" higher than the front.
6. Tighten jam nuts against sleeve.

Cutting Height (Normal Mowing) - Wings

1. Lower wings to normal mowing position.
2. Loosen the jam nut on the adjustable link (turn buckle).
3. Lengthening the link will raise the wing, shortening the link will lower the wing. The rear edge of the wing should be parallel to the ground.

When using the cutter to shred, the rear of the cutter deck should be approximately 1/2" to 1" lower than the front.

TRACTOR OPERATION

Use care when operating around tree limbs and other low objects. Avoid being knocked off tractor and being injured.

Only use a tractor with a Roll Over Protection Structure (ROPS) and seat belt. Securely fasten seat belt.

The cutter is operated with tractor controls. Engage the PTO at a low rpm to prevent excessive loads on the cutter drive system. Increase throttle to recommended PTO operating RPM.

Be sure operator is familiar with all controls and can stop tractor and cutter quickly in an emergency. The operator should give complete, undivided attention to operating tractor and cutter.

CUTTER OPERATION

When beginning operation of the cutter, make sure that all persons are in a safe location.

Power for operating the cutter is supplied by the tractor PTO. Operate PTO at 540.

Know how to stop the tractor and cutter quickly in an emergency.

Engage PTO at a low engine, rpm to minimize stress on the drive system and gearbox.

With PTO engaged, raise PTO speed to 540 and maintain throughout cutting operation.

Gearbox protection is provided by a slip clutch with replacement fiber disc. The slip clutch is designed to slip when excessive torsional loads occur.

Move slowly into material. Adjust tractor ground speed to provide a clean cut without lugging the tractor engine.

Use a slow ground speed for better shredding.

Proper ground speed will depend on the terrain and the material's height, type, and density.

Normally, ground speed will range from 2 to 5 mph. Tall, dense material should be cut at a low speed; thin, medium-height material can be cut at a faster ground speed.

Always operate tractor PTO at 540 RPM to maintain blade speed and to produce a clean cut.

Under certain conditions tractor tires may roll down some grass and prevent cutting at the same height as the surrounding area. When this occurs, reduce your ground speed but maintain PTO at 540 RPM. The lower ground speed will permit grass to rebound partially.

Mowing Tips

WARNING

- **Look down and to the rear and make sure area is clear before operating in reverse.**

WARNING

- **Do not operate or transport on steep slopes.**
- **Do not stop, start, or change directions suddenly on slopes.**
- **Use extreme care and reduce ground speed on slopes and rough terrain.**
- **Watch for hidden hazards on the terrain during operation.**

CAUTION

- **Stop power unit and equipment immediately upon striking an obstruction. Turn off engine, remove key, inspect, and repair any damage before resuming operation.**

Maximum recommended ground speed for cutting or shredding is 6 miles per hour. Adjust tractor ground speed by using higher or lower gears to provide a clean cut without lugging tractor engine.

Tall material should be cut twice. Cut material higher the first pass. Cut at desired height at 90 degrees the second pass.

Remember, sharp blades produce cleaner cuts and use less power.

Before entering an area, analyze it to determine the best procedure. Consider the height and type of material to be cut and the terrain type (hilly, level or rough, etc.).

Shredding

The cutter may be used to shred various crops including green manure, straw, stubble, asparagus residue, corn stalks and similar crops in preparation for tilling. It may also be used to shred pruning in orchards, groves and vineyards.

Each shredding operation may require a different set-up. Start with front edge of cutter high. Adjust up or down as necessary with attitude rod. Experiment until you obtain the results you want.

When shredding attitude is set, check that the distance from the bottom rear edge of the wing to the ground matches the bottom edge of the rear center section to the ground.

TRANSPORTING

⚠ WARNING

■ Power unit must be equipped with ROPS or ROPS cab and seat belt. Keep seat belt securely fastened. Falling off power unit can result in death from being run over or crushed. Keep foldable ROPS system in “locked up” position at all times.

■ Always raise unit and install transport locks before transporting. Leak down or failure of mechanical or hydraulic system can cause equipment to drop.

■ Always attach safety chain to tractor drawbar when transporting unit.

■ Never exceed 20 mph (32.2 km/h) during transport.

■ Never allow riders on power unit or attachment.

■ Do not operate PTO during transport.

■ Do not operate or transport on steep slopes.

■ Do not operate or transport equipment while under the influence of alcohol or drugs.

⚠ CAUTION

■ Always comply with all state and local lighting and marking requirements.

Lock-Up

Always transport with wings and center frame in the raised, locked position.

Wing Lock-Up

1. Raise wing to the up position.
2. Remove safety pin and lock-up bar from storage position.
3. Place lock-up bar over cylinder pin and secure with safety pin.
4. Repeat steps 1 to 3 for opposite wing.
5. Lower cylinder against lock-up bars (Figure 2).

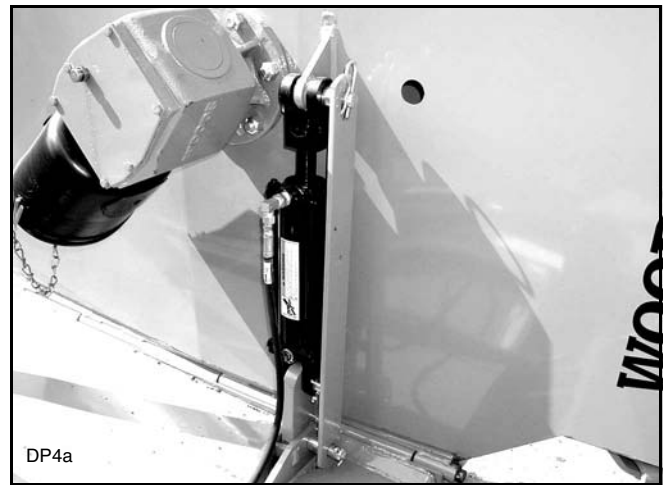

Figure 2. Transport Lock-Up Bar - Right Wing

Center Section Lock-Up

1. Raise cutter with hydraulic cylinder to maximum height.
2. Rotate transport lock into position over cylinder rod (Figure 3).

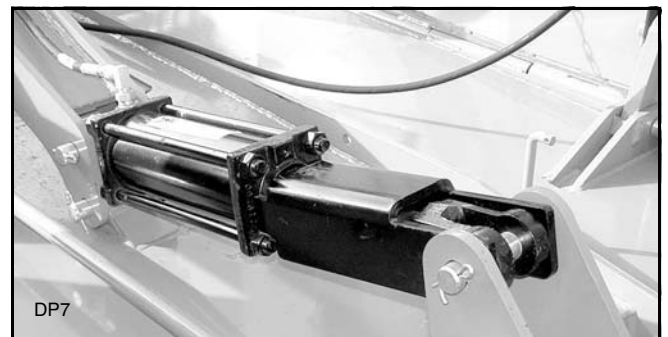

Figure 3. Transport Lock In Transport Position

3. Lower cutter against transport lock.
4. To lower cutter for operation, extend hydraulic cylinder to raise cutter. Rotate transport lock back away from cylinder rod (Figure 4).
5. Lower cutter to desired cutting height.



Figure 4. Transport Lock In Operation Position

STORAGE

Follow these steps when storing your cutter:

1. Clean cutter before storing. See page 23 for cleaning instructions. Store on level, solid ground.
2. Disconnect driveline and secure up off the ground.
3. Lower wings to ground.
4. Raise cutter center section and pin transport bar in raised position.
5. Attach parking jack and raise tongue weight off tractor drawbar.
6. Place wedge blocks at front and rear of wheels on center section and each wing to prevent wheel rotation.
7. Securely block all four corners of center section and each wing with jack stands.
8. Remove hydraulic hoses after tractor is turned off and all system pressure is released by operating valve levers several times.
9. Remove safety tow chain.
10. Remove retainer pin and high strength drawbar pin.
11. Keep children and bystanders away from storage area.

PRE-OPERATION CHECK LIST

(OWNER'S RESPONSIBILITY)

- ___ Review and follow all safety rules and safety decal instructions on page 7 through page 13.
- ___ Check that all safety decals are installed and in good condition. Replace if damaged.
- ___ Check that equipment is properly and securely attached to tractor.
- ___ Make sure driveline spring-activated locking pin or collar slides freely and is seated firmly in tractor PTO spline groove.
- ___ Check all lubrication points and grease as instructed in lubrication information. Make sure the PTO slip joint is lubricated and that the gear-box fluid levels are correct.
- ___ Set tractor PTO at correct rpm for your equipment.
- ___ Lubricate all grease fitting locations. Make sure PTO shaft slip joint is lubricated.
- ___ Check that all hydraulic hoses and fittings are in good condition and not leaking before starting tractor. Check that hoses are not twisted, bent sharply, kinked, frayed, or pulled tight. Replace any damaged hoses immediately.
- ___ Check that all hardware is properly installed and secured.
- ___ Check cutting height and attitude adjustment.
- ___ Raise and lower equipment to make sure air is purged from hydraulic cylinders and hoses. Raise and lower equipment to make sure air is purged from hydraulic cylinders and hoses.
- ___ Check that blades are sharp and secure and cutting edge is positioned to lead in a counterclockwise rotation.
- ___ Make sure tractor ROPS or ROPS cab and seat belt are in good condition. Keep seat belt securely fastened during operation.
- ___ Check that shields and guards are properly installed and in good condition. Replace if damaged.
- ___ Before starting engine, operator must be in tractor seat with seat belt fastened. Place transmission in neutral or park, engage brake and disengage tractor PTO.
- ___ Inspect area to be cut and remove stones, branches, or other hard objects that might be thrown and cause injury or damage.
- ___ Inspect rubber or chain shielding and replace any damaged rubber shield or missing links.
- ___ Make sure tractor 3-point lift links do not interfere with hydraulic hoses or driveline throughout full turning range.



OWNER SERVICE

The information in this section is written for operators who possess basic mechanical skills. If you need help, your dealer has trained service technicians available. For your protection, read and follow the safety information in this manual.

WARNING

- Keep all persons away from operator control area while performing adjustments, service, or maintenance.

- Before working underneath, disconnect driveline from tractor, lower wings to ground, raise cutter, and pin transport bar in raised position. Attach parking jack and lower to ground. Securely block all four corners of center section and each wing with jack stands. Blocking up prevents the cutter from dropping due to hydraulic leak down, hydraulic system failure, or mechanical component failure.

- Service and maintenance work not covered in OWNER SERVICE must be done by a qualified dealership. Special skills, tools, and safety procedures may be required. Failure to follow these instructions can result in serious injury or death.

- Before servicing, adjusting, repairing or unplugging, stop tractor engine, place all controls in neutral, set park brake, remove ignition key, and wait for all moving parts to stop.

- Never perform service or maintenance with engine running.

CAUTION

- If you do not understand any part of this manual and need assistance, see your dealer.

- Always wear relatively tight and belted clothing to avoid entanglement in moving parts. Wear sturdy, rough-soled work shoes and protective equipment for eyes, hair, hands, hearing, and head; and respirator or filter mask where appropriate.

BLOCKING METHOD

To minimize the potential hazards of working underneath the cutter, follow these procedures:

WARNING

- Before performing any service or maintenance, lower equipment to ground or block securely, turn off engine, remove key, and disconnect driveline from tractor PTO.

- Never go underneath equipment (lowered to the ground or raised) unless it is properly blocked and secured. Never place any part of the body underneath equipment or between moveable parts even when the engine has been turned off. Hydraulic system leak down, hydraulic system failures, mechanical failures, or movement of control levers can cause equipment to drop or rotate unexpectedly and cause severe injury or death. Follow Operator's Manual instructions for working underneath and blocking requirements or have work done by a qualified dealer.

Do not position jackstands under wheels, axles, or wheel supports. Components can rotate and cause cutter to fall.

1. Jackstands with a load rating of 1000 lbs. or more are the only approved blocking device for this cutter. Install jackstands (shown by Xs in Figure 5) under the cutter before working underneath unit.
2. Consider the overall stability of the blocked unit. Just placing jackstands underneath will not ensure your safety.

The working surface must be level and solid to support the weight on the jackstands. Make sure jackstands are stable, both top and bottom. Make sure cutter is approximately level.

3. With full cutter weight lowered onto jackstands, test blocking stability before working underneath.
4. If cutter is attached to tractor when blocking, set the brakes, remove key, and block cutter before working underneath.
5. Securely block rear tractor wheels, in front and behind. Tighten tractor lower 3-point arm anti-sway mechanism to prevent side-to-side movement.

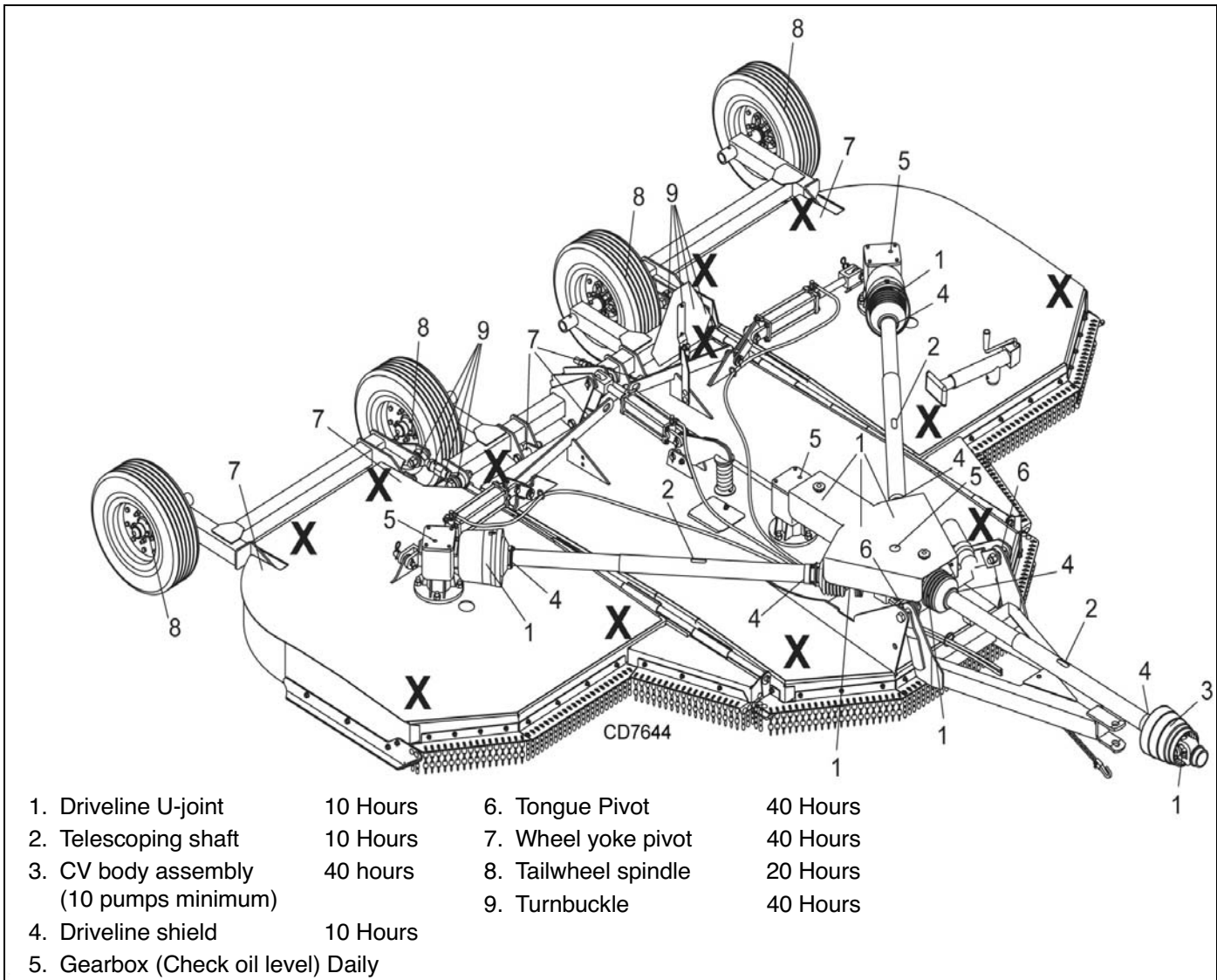

Figure 5. Jackstand Placement and Lubrication Points

LUBRICATION

Do not let excess grease collect on or around parts, particularly when operating in sandy areas.

See Figure 5 for lubrication points and frequency or lubrication based on normal operating conditions. Severe or unusual conditions may require more frequent lubrication.

Use a lithium grease of #2 consistency with a MOLY (molybdenum disulfide) additive for all locations unless otherwise noted. Be sure to clean fittings thoroughly before attaching grease gun. One good pump of most guns is sufficient when the lubrication schedule is followed.

Gearbox Lubrication

For gearbox, use a high quality gear oil with a viscosity index of 80W or 90W and an API service rating of GL-

4 or -5 in gearboxes. Fill gearbox until oil runs out the side plug on gearbox. Check gearbox daily for evidence of leakage, and contact your dealer if leakage occurs. Use sealant on vent plug threads during installation. Check vent plug periodically and clean if it doesn't relieve pressure.

Driveline Lubrication

1. Lubricate the driveline slip joint every eight operating hours. Failure to maintain proper lubrication could result in damage to U-joints, gearbox, and driveline.
2. Lower cutter to ground, disconnect driveline from tractor PTO shaft, and slide halves apart but do not disconnect from each other.
3. Apply a bead of grease completely around male half where it meets female half. Slide drive halves over each other several times to distribute grease.

Seasonal Lubrication

In addition to the daily recommended lubrication, a more extensive application is recommended seasonally.

1. Fill CV double yokes with 20 pumps of grease with the joints in a straight line.
2. Articulate CV body to maximum angle several times to ensure full coverage of joints.
3. Place joints in the straight position and add 10 additional pumps of grease to both joints.
4. Wipe telescoping drive clean of all old grease and contaminants.
5. Add a thin layer of new grease over telescoping drive.

BLADES

WARNING

■ Before working underneath, read manual instructions, securely block up, and check stability. Secure blocking prevents equipment from dropping due to hydraulic leak down, hydraulic system failure, or mechanical component failure.

Blade Removal (Figure 6)

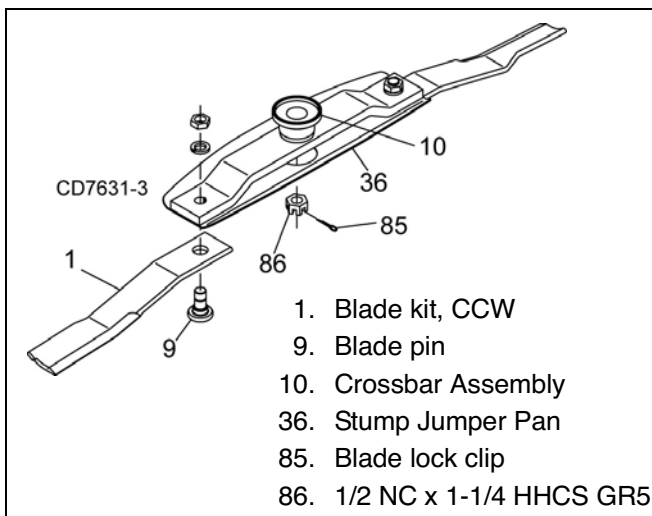

Figure 6. Blade Assembly

1. Disconnect driveline from tractor PTO.
2. Raise cutter and block securely (see Figure 5).

3. Align crossbar (10) with blade access hole in the cutter frame. Remove nut and lock washer. Carefully drive blade pin (9) out of crossbar.
4. Rotate crossbar and repeat for opposite blade.

NOTICE

■ If blade pin (9) is seized in crossbar and extreme force will be needed to remove it, support crossbar from below to prevent gearbox damage.

Blade Installation (Figure 6)

CAUTION

■ Your dealer can supply genuine replacement blades. Substitute blades may not meet original equipment specifications and may be dangerous.

NOTICE

■ Crossbar rotation has clockwise rotation on left gearbox and counterclockwise rotation on the right and center gearboxes when looking down on cutter. Be sure to install blade cutting edge to lead in correct rotation.

NOTE: Always replace or sharpen both blades at the same time.

1. Inspect blade pin (9) for nicks or gouges, and if you find any replace the blade pin.
2. Insert blade pin through the blade. Blade should swivel on blade pin; if it doesn't, determine the cause and correct.
3. Align crossbar (10) with blade access hole in cutter frame. Apply a liberal coating of Never-Seez® or equivalent to blade pin and crossbar hole. Make sure blade offset is down away from cutter.
4. Insert blade pin (9) through blade and align key on blade pin with keyway in crossbar and stump jumper pan. Push blade pin through crossbar.
5. Insert lock washer and nut through blade access hole in cutter frame. Install on blade pin (9) and tighten to 450 lbs-ft.
6. Repeat steps for opposite side.

NOTE: Blade should be snug but should swivel on pin without having to exert excessive force.

Blade Sharpening

NOTICE

■ When sharpening blades, grind the same amount on each blade to maintain balance. Replace blades in pairs. Unbalanced blades will cause excessive vibration, which can damage gearbox bearings. Vibration may also cause structural cracks to cutter.

1. Sharpen both blades at the same time to maintain balance. Follow original sharpening pattern.
2. Do not sharpen blade to a razor edge—leave at least a 1/16" blunt edge.
3. Do not sharpen back side of blade.

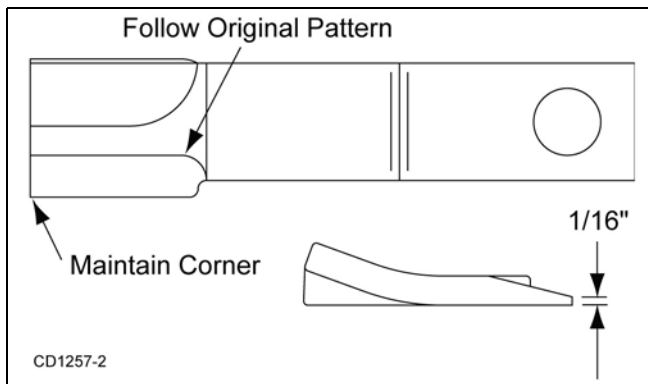

Figure 7. Blade Sharpening

SLIP CLUTCH ADJUSTMENT (FIGURE 8)

The slip clutch is designed to slip so that the gearbox and driveline are protected if the cutter strikes an obstruction.

A new slip clutch or one that has been in storage over the winter may seize. Before operating the cutter, make sure it will slip by performing the following operation:

1. Turn off tractor engine and remove key.
2. Remove driveline from tractor PTO.
3. Loosen six 10 mm cap screws (6) to remove all tension from Belleville spring plate (5).
4. Hold clutch hub (3) solid and turn shaft to make sure clutch slips.
5. If clutch does not slip freely, disassemble and clean the thrust plate faces (4), flange yoke (1), and clutch hub (3).
6. Reassemble clutch.
7. Tighten Belleville spring (5) until it is against the thrust plate (4) of the clutch, and then back off each of the six nuts by 2 full revolutions. The gap between Belleville spring and thrust plate should be 1/8" as shown in Figure 8.
8. If a clutch continues to slip when the spring is compressed to 1/8" gap, check friction discs (2) for excessive wear. Discs are 1/8" when new. Replace discs after 1/16" wear. Minimum disc thickness is 1/16".

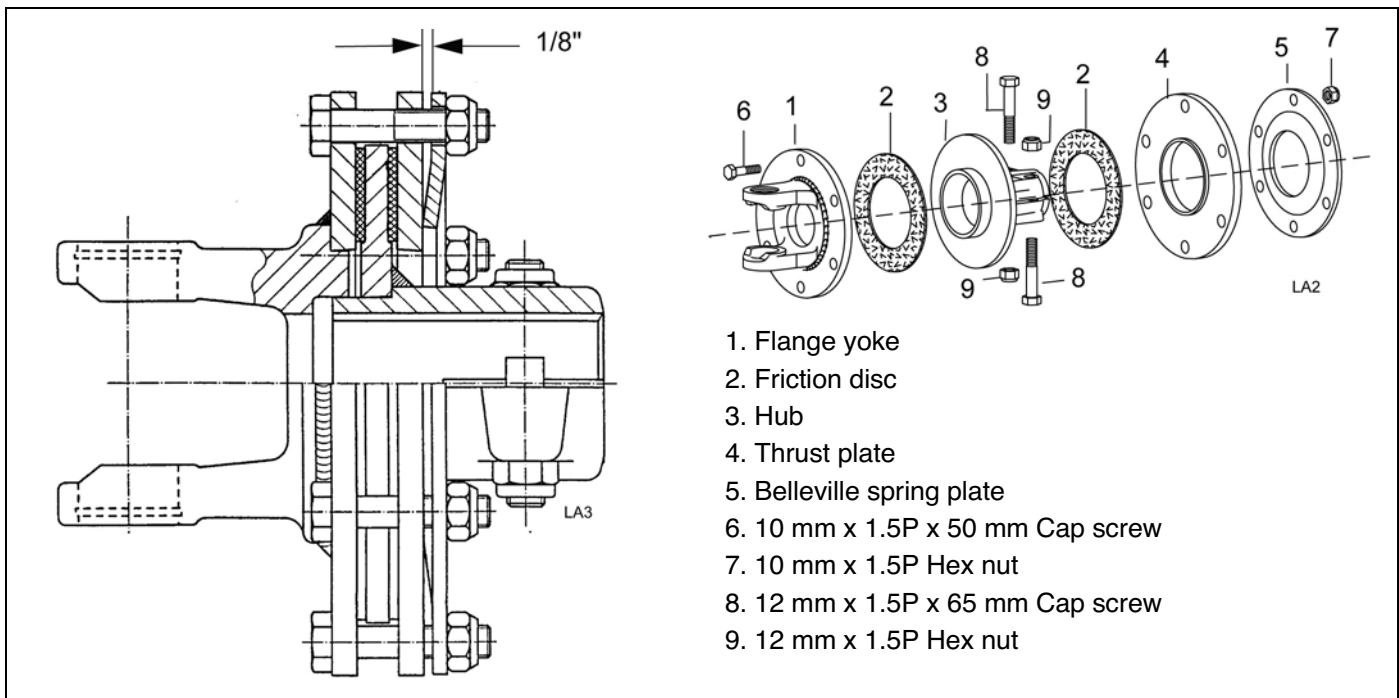

Figure 8. Slip Clutch Assembly

SHIELDING REPAIR

DANGER

■ Full chain or rubber shielding must be installed when operating in populated areas or other areas where thrown objects could injure people or damage property.

- If this machine is not equipped with full chain or rubber shielding, operation must be stopped when anyone comes within 300 feet (92 m).
- This shielding is designed to reduce the risk of thrown objects. The mower deck and protective devices cannot prevent all objects from escaping the blade enclosure in every mowing condition. It is possible for objects to ricochet and escape, traveling as much as 300 feet (92 m).

Repairing Rubber Shielding

1. Inspect belting and rear bands each day of operation.
2. Replace if bent, cracked, or broken.
3. Replace any missing hardware.

Repairing Optional Chain Shielding:

1. Inspect chain shielding each day of operation and replace any broken or missing chains as required.
2. Replace any missing hardware.

SERVICING TIRES SAFELY

Used Aircraft Tires (Figure 9)

WARNING



■ Explosive separation of tire and rim parts can cause serious injury or death. Release all air pressure before loosening bolts.

Do not attempt to mount a tire unless you have the proper equipment and experience to perform the job.

Always maintain the correct tire pressure. Do not inflate tires above the recommended pressure. Never weld or heat a wheel and tire assembly. The heat can cause an increase in air pressure and result in a tire explosion. Welding can structurally weaken or deform the wheel.

When inflating tires, use a clip-on chuck and an extension hose long enough to allow you to stand to the side — not in front of or over the tire assembly. Use a safety cage if available.

Check wheels for low pressure, cuts, bubbles, damaged rims, or missing lug bolts and nuts.

Never remove split rim assembly hardware (A) with the tire inflated.



Figure 9. Split Rim Tire Servicing

CLEANING

After Each Use

- Remove large debris such as clumps of dirt, grass, crop residue, etc. from machine.
- Inspect machine and replace worn or damaged parts.
- Replace any safety decals that are missing or not readable.

Periodically or Before Extended Storage

- Clean large debris such as clumps of dirt, grass, crop residue, etc. from machine.
- Remove the remainder using a low-pressure water spray.
 1. Be careful when spraying near scratched or torn safety decals or near edges of decals as water spray can peel decal off surface.
 2. Be careful when spraying near chipped or scratched paint as water spray can lift paint.
 3. If a pressure washer is used, follow the advice of the pressure washer manufacturer.
- Inspect machine and replace worn or damaged parts.
- Sand down scratches and the edges of areas of missing paint and coat with Woods spray paint of matching color (purchase from your Woods dealer).
- Replace any safety decals that are missing or not readable (supplied free by your Woods dealer). See Safety Decals section for location drawing.

TROUBLESHOOTING

PROBLEM	POSSIBLE CAUSE	SOLUTION
Does not cut	Dull blades Worn or broken blades Incorrect PTO speed Ground speed too fast Drive not functioning (blades do not turn when PTO is running) Gearbox malfunction Excessive clutch slippage Incorrect blade direction	Sharpen blades. Replace blades. (Replace in pairs only.) Set at rated PTO speed. Reduce ground speed. Check drive shaft connection. Check gearbox. Repair gearbox. Adjust clutch. Check to be sure blade edge is correct for direction of rotation.
Streaks or ragged cut	Broken or worn blades Attitude incorrect Ground speed too fast Excessive cutting height Excessive lush and tall vegetation	Replace or sharpen blades. Level machine. Reduce ground speed. Lower cutting height. (Note: Set height so blades do not frequently hit ground.) Recut at 90° to first pass.
Excessive side skid wear	Running with skids continuously on ground	Raise cutting height or adjust.
Excessive clutch slippage	Clutch out of adjustment Clutch discs worn; wear stops contacting opposite plate Blades hitting ground	Adjust clutch. Replace discs. Raise cutting height.
Vibration	Broken blade Bearing failure Drawbar length incorrect	Replace blades in pairs. Check gearbox shafts for side play. Reset drawbar length
Blades hitting deck	Bent blades or crossbar	Replace bent blades or crossbar.
Unit will not raise	Low oil	Add hydraulic oil.
Unit doesn't cut level	Wing section cuts lower than center Wing section cuts higher than center	Lengthen turnbuckle connecting center yoke to wing wheel yoke. Shorten turnbuckle connecting center yoke to wing wheel yoke.

DEALER SERVICE

The information in this section is written for dealer service personnel. The repair described here requires special skills and tools. If your shop is not properly equipped or your mechanics are not properly trained in this type of repair, you may be time and money ahead to replace complete assemblies.

WARNING

■ **Before working underneath, read manual instructions, securely block up, and check stability. Secure blocking prevents equipment from dropping due to hydraulic leak down, hydraulic system failure, or mechanical component failure.**

■ **Keep all persons away from operator control area while performing adjustments, service, or maintenance.**

CAUTION

■ **Always wear relatively tight and belted clothing to avoid getting caught in moving parts. Wear sturdy, rough-soled work shoes and protective equipment for eyes, hair, hands, hearing, and head; and respirator or filter mask where appropriate.**

GEARBOX MAINTENANCE

NOTE: Read this entire section before starting any repair. Many steps are dependent on each other.

1. Fill gearbox with SAE 80W or 90W gear lube. Proper oil level is between lowest ring and end of dipstick.

NOTE: Repair to this gearbox is limited to replacing bearings, seals, and gaskets. Replacing gears, shafts, and a housing is not cost effective. Purchasing a complete gearbox is more economical.

2. Inspect gearbox for leakage and bad bearings. Leakage is a very serious problem and must be corrected immediately.

NOTE: Bearing failure is indicated by excessive noise and side-to-side or end-play in gear shafts.

Seal Replacement (Figure 10)

Recommended sealant for gearbox repair is Permatex® Aviation 3D Form-A-Gasket or equivalent.

Leakage can occur at the vertical or horizontal gaskets and shaft seals.

Leakage at the horizontal gasket or seal can be repaired without removing the gearbox from the cutter.

Seal Installation

NOTE: Proper seal installation is important. An improperly installed seal will leak.

1. Clean area in housing where seal outer diameter (OD) seats. Apply a thin coat of Permatex.
2. Inspect area of shaft where seal seats. Remove any burrs or nicks with an emery cloth.
3. Lubricate gear shaft and seal lips.
4. Place seal squarely on housing, spring-loaded lip toward housing. Select a piece of pipe or tubing with an OD that will sit on the outside edge of the seal but will clear the housing. Tubing with an OD that is too small will bow seal cage and ruin seal.
5. Carefully press seal into housing, avoiding distortion to the metal seal cage.

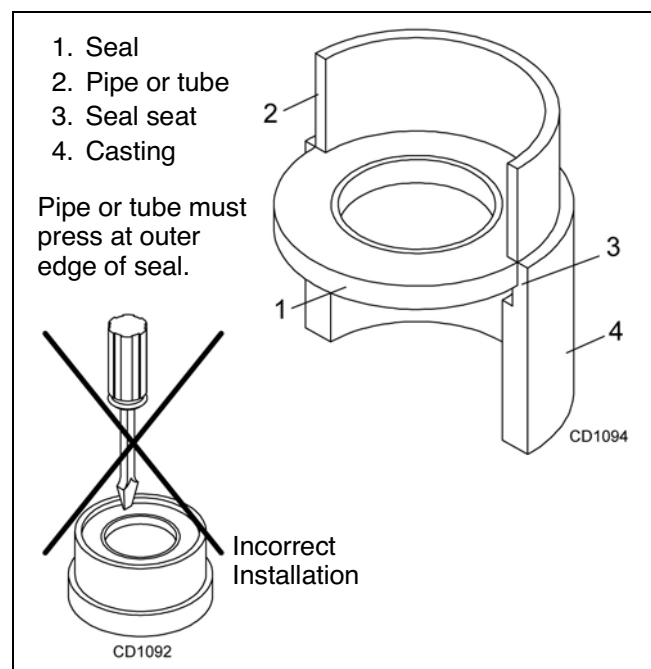

Figure 10. Seal Installation

VERTICAL SHAFT SEAL REPAIR (SPINDLE BOX)

Refer to Figure 11.

1. Disconnect and remove the driveline from the gearbox.
2. Remove vent plug (3) and siphon gear lube from housing through this opening.
3. Remove crossbar (See "CROSSBAR REMOVAL" on page 31.).
4. Remove vertical shaft seal (16). Replace with new seal (See ". Seal Installation" on page 25.).

Vertical seal should be recessed in housing. Horizontal seal should be pressed flush with outside of housing.

NOTE: Distortion to seal cage or damage to seal lip will cause seal to leak.

5. Fill gearbox with SAE 80W or 90W gear lube until it runs out the level plug.
6. Remove and replace any seal damaged in installation.

HORIZONTAL SHAFT SEAL REPAIR

Refer to Figure 11.

1. Disconnect and remove the driveline from the gearbox.
2. Remove vent plug (3) and siphon gear lube from housing through this opening.
3. If the leak occurred at either end of horizontal shaft, remove oil cap (24) and/or oil seal (10). Replace with new one (refer to . Seal Installation, page 25).
4. Fill gearbox with SAE 80W or 90W gear lube until it runs out the level plug.

SPINDLE GEARBOX REPAIR

NOTE: Replacing gears, shafts, bearings, and seals may not be cost effective. Purchasing a complete gearbox may be more economical.

REMOVE GEARBOX FROM CUTTER

Refer to Figure 11.

1. Disconnect and remove the driveline from the gearbox.
2. Remove vent plug (3) and siphon gear lube from housing through this opening.
3. Remove cotter pin, washer, and nut from vertical shaft and remove crossbar (see CROSSBAR REMOVAL, page 31).

4. Remove the four bolts that attach gearbox to cutter and remove gearbox. Gearbox is heavy; do not attempt to move without mechanical assistance.

DISASSEMBLE GEARBOX

Refer to Figure 11.

1. Remove 3/8" plug from side of gearbox and pour out gear oil.
2. Remove oil cap (24) (to be replaced).
3. Remove snap ring (9) and shim (5) from input shaft (11).
4. Support gearbox in hand press and push on input shaft (11) to remove bearing (23).
5. Remove top cover (4) from housing. Remove gear (6) from inside housing.
6. Remove oil seal (10) from front of housing (to be replaced).
7. Remove snap ring (9) and shim (5) from front of housing (1).
8. Remove input bearing (7) by using a punch and hammer from outside of housing.
9. Support housing in vise in a horizontal position.
10. The castle nut (21), cotter pin (8), and washer (20) are already removed with the crossbar. Remove the protective screen (17) and seal (16).
11. Remove cotter pin (18), castle nut (12), and washer (25) from output shaft (19).
12. Remove output shaft (19) by using a punch and hammer and tap on top to drive down.
13. Remove gear (13) and shim (14) from inside housing.
14. Remove bearing (15) by using a punch and hammer from the top, outside the housing.
15. Support housing upside down (top cover surface) and remove bearing (15) by using a punch and hammer from the bottom side of the housing.
16. Inspect gears for broken teeth and wear. Some wear is normal and will show on loaded side. Forged gear surfaces are rough when new. Check that wear pattern is smooth.
17. Inspect vertical and horizontal shafts for grooves, nicks, or bumps in the areas where the seals seat. Resurface any damage with emery cloth.
18. Inspect housing and caps for cracks or other damage.

1. Gearbox housing
2. Cap screw 14 mm x 1.25
3. Vent plug
4. Top cover
5. Shim kit
6. Crown gear
7. Bearing cup & cone
8. Cotter pin B6 x 60 mm
9. Snap ring
10. Seal
11. Input shaft
12. Castle nut, metric M30 x 1.5
13. Pinion gear
14. Shim kit
15. Bearing cup & cone
16. Seal 50 x 90 x 10
17. Protective washer
18. Cotter pin
19. Output shaft
20. Flat washer
21. Castle nut, metric M30 x 2.0
22. Plug, 3/8 NPT
23. Ball bearing
24. Seal, 72 x 10
25. Shim, 44 x 30.3 x 1

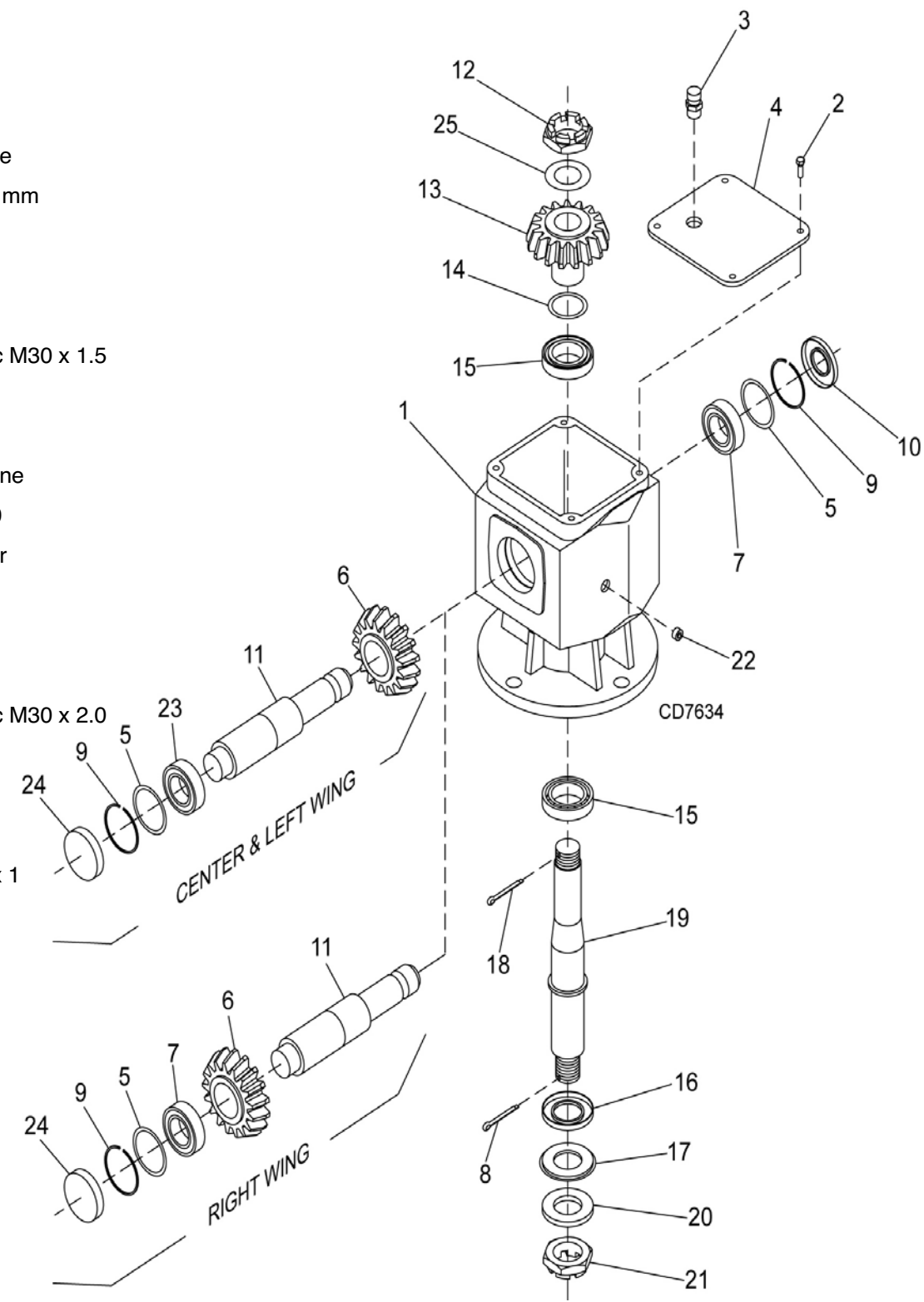

Figure 11. Spindle Gearbox Assembly

ASSEMBLE GEARBOX

Refer to Figure 11.

1. Clean housing, paying specific attention to areas where gaskets will be installed.
2. Wash housing and all components thoroughly. Select a clean area for gearbox assembly. Replace all seals, bearings, and gaskets. All parts must be clean and lightly oiled before reassembling.
3. Insert output bearings (15) in the housing, using a round tube of the correct diameter and a hand press.
4. Slide output shaft (19) through both bearings (15) until it rests against top bearing (15).
5. Slide shim (14) over output shaft (19).
6. Press gear (13) onto output shaft (19) and secure with washer (25), castle nut (12), and cotter pin (18).
7. Apply grease to lower seal lips (16) and press seal (16) over output shaft (19), using a tube of the correct diameter. Be sure not to damage the seal lip.

Press in housing so that seal is recessed. Install protective screen (17) and position it together with dual lip seal (16) by pressing it into position. Verify that snap ring is seated correctly.
8. Press bearing (7) into the housing, using a round tube of the correct diameter and a hand press. Secure with shim (5) and snap ring (9).
9. Place gear (6) through top of housing and align gear (6) and gear (13) so that gear teeth are a match.
10. While holding gear (6) in place, slide input shaft (11) through gear (6) and bearing (7). Align splines on shaft (11) and gear (6).

11. Slide bearing (23) over input shaft (11) and press bearing onto input shaft (11), using a round tube of the correct diameter and a hand press.
12. Slide shim (5) over input shaft (11) and secure with snap ring (9).
13. Check input shaft end float by moving the input shaft (11) by hand. If end float is higher than 0.012", insert shim between input shaft (11) and rear bearing (23). Repeat until end float is less than 0.012". Check rotational torque by hand. The torque should be less than 2.2 lbs-inch.
14. Check that the gear backlash is between 0.006" and 0.016". You should not have to adjust the backlash.
15. Press in input oil seal (10), using tube of correct diameter. Be careful not to damage seal lip.
16. Press oil cap (24) on to cover the rear of housing, using a tube of the correct diameter.
17. Check gearbox housing for leaks by plugging all holes except one. Apply 4 psi compressed air and immerse the gearbox in water to verify that there are no leaks.
18. Remove gearbox from water and dry off with compressed air. Add SAE 80W or 90W EP oil until it runs out of side level hole. Tighten all plugs.

REINSTALL GEARBOX

NOTE: Gearbox is heavy: do not attempt to move without mechanical assistance.

1. Set gearbox on cutter and fasten with bolts and nuts. Torque bolts to 300 lbs-ft.
2. Attach crossbar (See "CROSSBAR REMOVAL" on page 31.).

SPLITTER GEARBOX REPAIR (Figure 12)

Removal from Cutter

1. Disconnect and remove all drivelines from gearbox.
2. Remove the four cap screw and lock washers that secure gearbox to cutter, and remove gearbox.

NOTE: Gearbox is heavy: do not attempt to move it without mechanical assistance.

Disassembly

Center Shaft

1. Remove plug from side of gearbox and pour out the gear oil.
2. Remove seal (11, to be replaced) from the front and rear of the center shaft (14).
3. Remove snap ring (10) and shim (12) from the front and rear of the center shaft (14).
4. Support gearbox in a hand press and push on the rear of the center shaft.
5. Remove bearing (13) from center shaft (14).
6. Remove six cap screws (20) and top cover (21) from the gearbox housing.
7. Remove gear (17) and bearing (16).
8. Snap ring (15) does not have to be removed from shaft (14) unless it is damaged.

Side Shaft

9. Remove seal (2, to be replaced) from the output shaft (1).
10. Remove snap ring (4) and shim (8) from output shaft (1).
11. Support gearbox in hand press. Using a punch through the front opening of the gearbox and, push shaft (1) and bearing (5) out the backside of housing.
12. Remove gear (6) from inside housing.
13. Remove bearing (7) and shim (8) by using a hammer and punch through front opening of the gearbox and force them out the backside of the housing.
14. Repeat steps 7 through 11 for opposite side shaft.

Inspect Components

15. Inspect gears for broken teeth and wear. Some wear is normal and will show on the loaded side of the teeth. Forged gear surfaces are rough when new. Check that wear pattern is smooth.
16. Inspect shafts for grooves, nicks, or bumps in the areas where seals seat. Resurface any damage with emery cloth or replace shaft.

17. Inspect housing and caps for cracks or other damage.

Assembly

1. Clean housing, pay specific attention to areas where gaskets are installed.
2. Wash housing and all components thoroughly.
3. Select a clean work area to assemble gearbox.
4. Replace all seals, bearings, and gaskets.
5. All parts must be clean and lightly oiled before assembly.

Side Shaft

6. Insert bearing (7) and shim (8) in housing using a round tube of the same size diameter and a hand press.
7. Place gear (6) inside the housing and slide output shaft (1) through gear (6) and into bearing (7).
8. Slide bearing (5) and shim (8) over output shaft. Secure with snap ring (4).
9. Check end play of shaft by moving it in and out. If end play is more than 0.012", insert another shim (8) between snap ring and bearing. Repeat process until end play is less than 0.012".
10. Check rotational torque. Torque should be less than 2.2 lbs-inch gear.
11. Place seal (2) over shaft and press into housing using a tube of the same diameter. Seal should be flush with housing when properly installed.
12. Repeat steps 6 through 10 for opposite side shaft.

Center Shaft

13. Place gear (17) inside housing and slide center shaft (14) through the gear from the front of the housing.
14. Slide bearings (16 & 13) and shims (12) over each end of the center shaft (14). Secure bearings into position using snap rings (10).
15. Check end play of shaft by moving it in and out. If end play is more than 0.012", insert another shim (12) between snap ring and bearing. Repeat process until end play is less than 0.012".
16. Check rotational torque. Torque should be less than 2.2 lbs-inch gear.
17. Check gear backlash, backlash should be between 0.006" and 0.016". You should not have to adjust for backlash.
18. Place seal (11) over shaft and press into housing using a tube of the same diameter. Seal should be flush with housing when properly installed. Repeat process for opposite end shaft.

Check Gearbox

1. Place top cover (21) on housing and secure into position using six cap screws (20).
2. Check gearbox for leaks by: plugging all holes except one, applying 4 psi of compressed air, and immersing gearbox in water. Verify gearbox does not leak.
NOTE: Excessive air pressure will damage seals.
3. Remove gearbox from water and dry off.
4. Remove upper plug (3) on right side of housing. Add SAE 80W or 90W EP oil until it runs out side level hole. Replace plug.

5. Install breather (18) in top cover.

Reinstallation on Cutter

NOTE: Gearbox is heavy: do not attempt to move it without mechanical assistance.

1. Place gearbox on cutter and secure into position using four cap screws and lock washers.
2. Torque hardware to 300 lbs-ft.
3. Attach all drivelines to gearbox.
4. Install all shields.

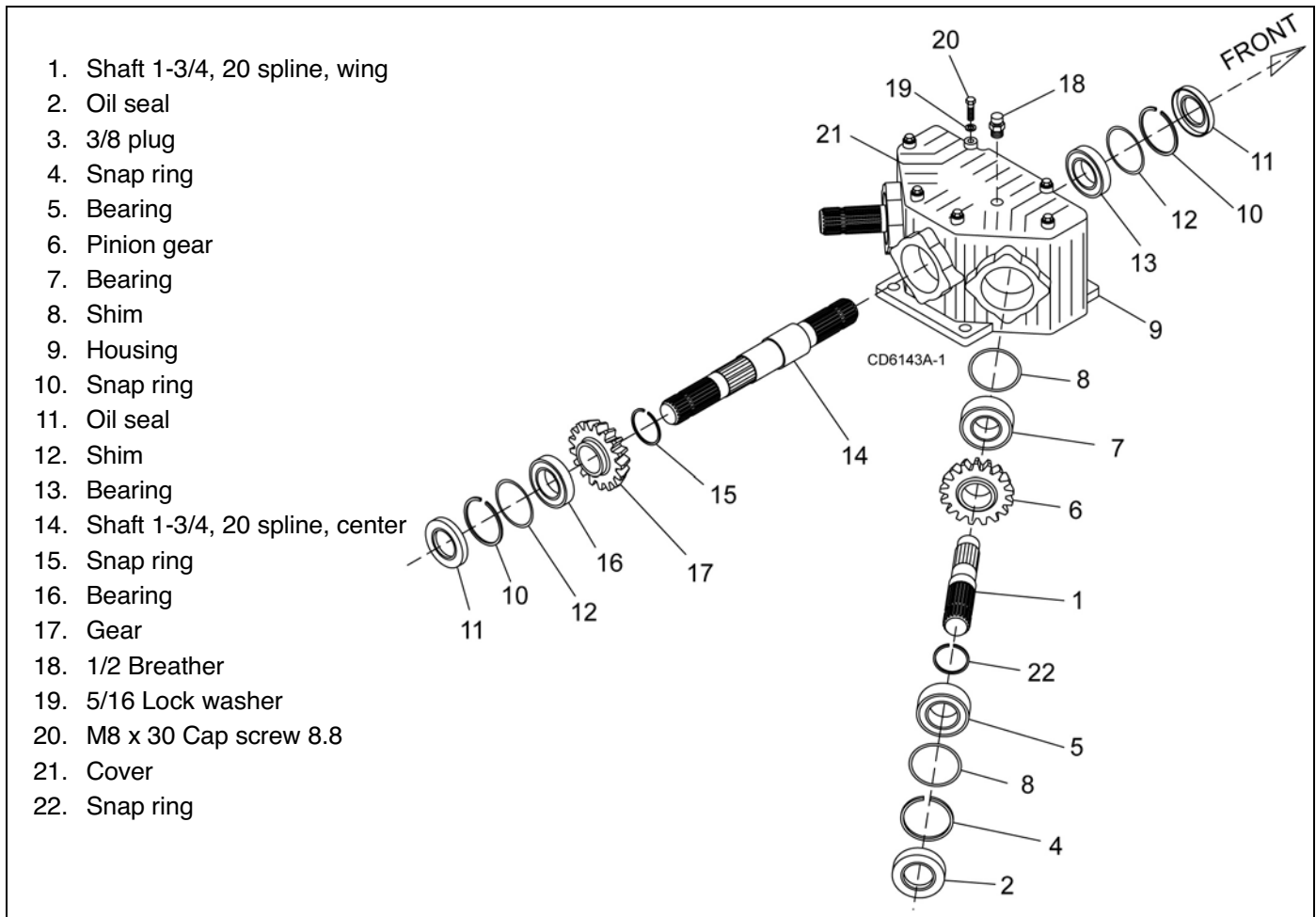

Figure 12. Splitter Gearbox Assembly

CROSSBAR REMOVAL

1. It is necessary to gain access to bottom side of cutter for crossbar removal. See Blocking Method page 19.

NOTE: You will need to use either the puller screw (Item 6, Figure 14) or a small hydraulic jack to remove the crossbar.

2. Remove blades from crossbar as shown in Figure 13.

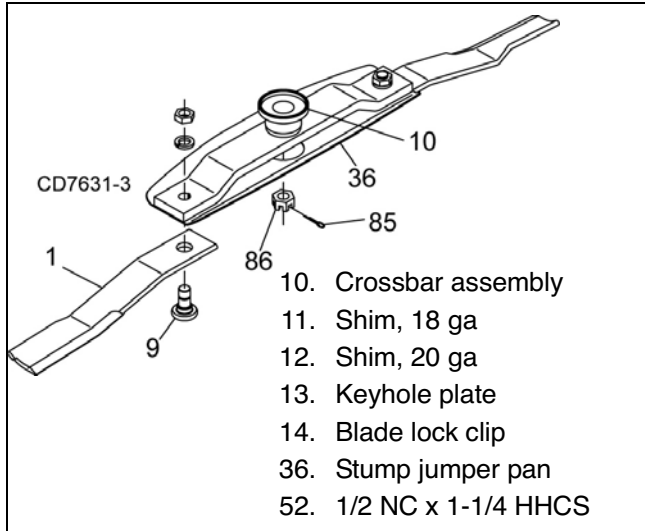

Figure 13. Blade Removal

3. Refer to Figure 14. Remove cotter pin from bottom of crossbar and remove nut and washer.

4. Attach a clevis (1) to each end of crossbar, using blade pins, and nuts.

5. Position tube assembly (5) with threaded nut (4) toward crossbar for puller screw removal or down for hydraulic jack removal.

6. For removal with puller screw, attach tube (5) to each clevis with bolts (2) and nuts (3). Place pad (4) in nut and thread puller screw (6) into nut from bottom. Tighten until pad is solid against gearbox shaft. For best results, strike head of puller screw with a hammer while tightening with a wrench.

7. For removal with a jack, attach tube to each clevis with puller links (7), bolts (2), and nuts (3). Place jack on tube with end of jack pressing against gearbox shaft. Slowly apply force with jack.

NOTE: Hydraulic jack will not operate if tipped more than 90°. Use care to prevent bending crossbar during removal.

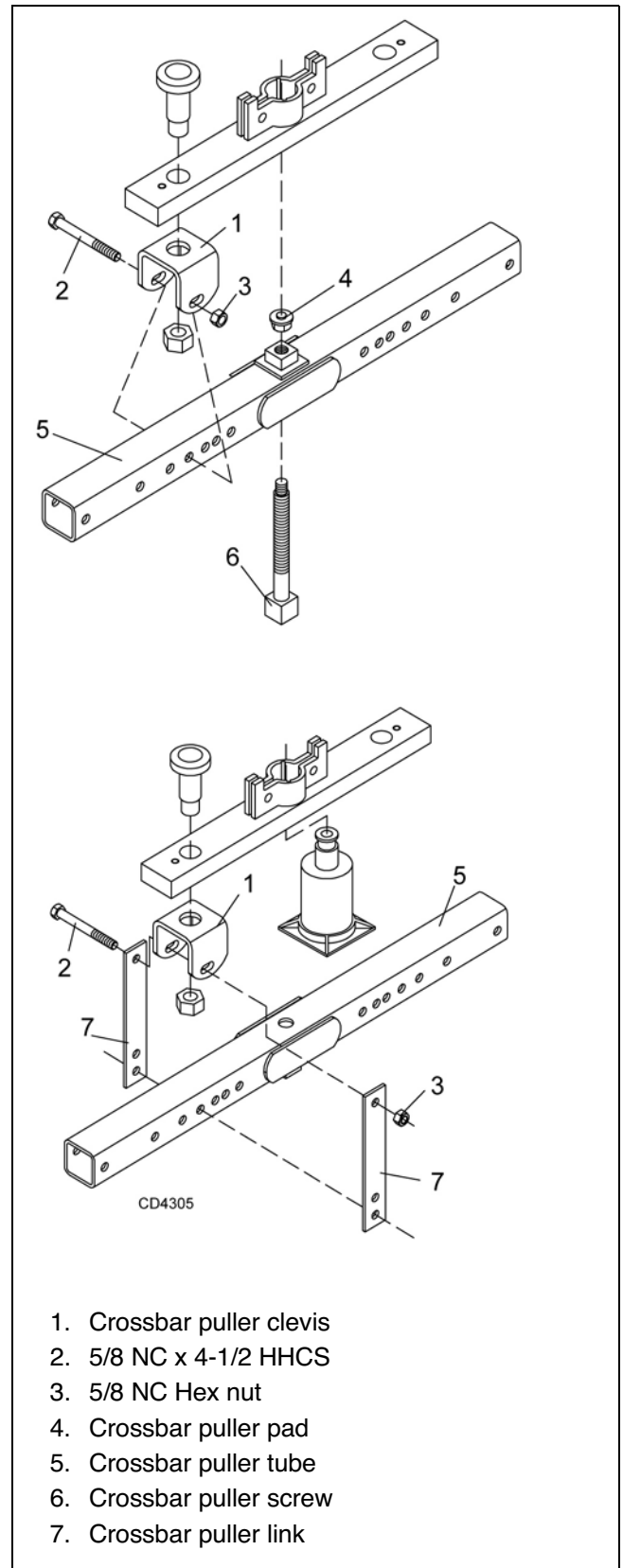

Figure 14. Crossbar Removal

CROSSBAR INSTALLATION

1. Using emery cloth (220 or finer), remove surface rust, Loctite® and foreign material from hub, splined gearbox vertical shaft, and crossbar assembly.
2. Slide crossbar assembly (10) onto splined shaft. Install nut (86) and align a slot with hole in splined shaft. Torque nut to 450 lbs-ft.
3. Install cotter pin (85) through slot in nut and bend ends over.

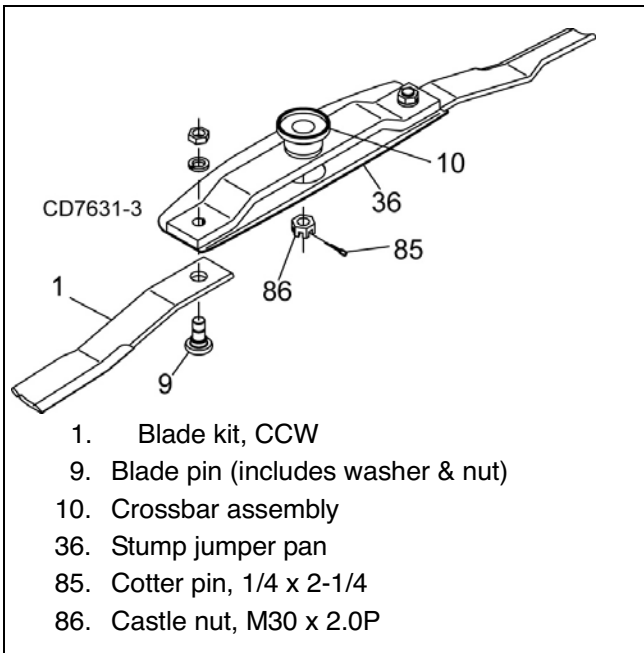

Figure 15. Crossbar Assembly Installation

UNIVERSAL JOINT REPAIR

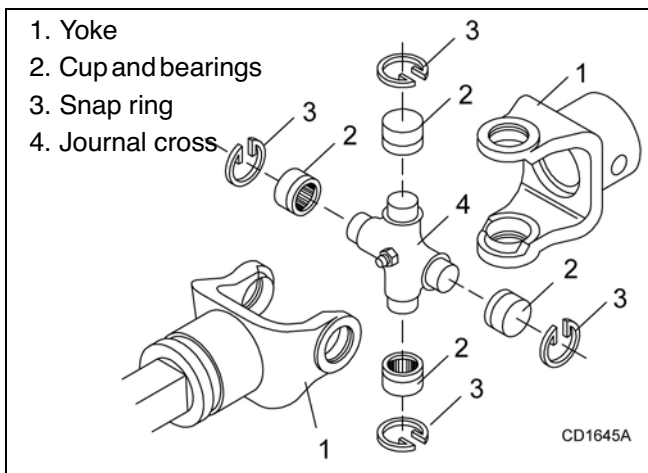

Figure 16. U-Joint Exploded View

U-Joint Disassembly

1. Remove external snap rings from yokes in four locations as shown in Figure 16.

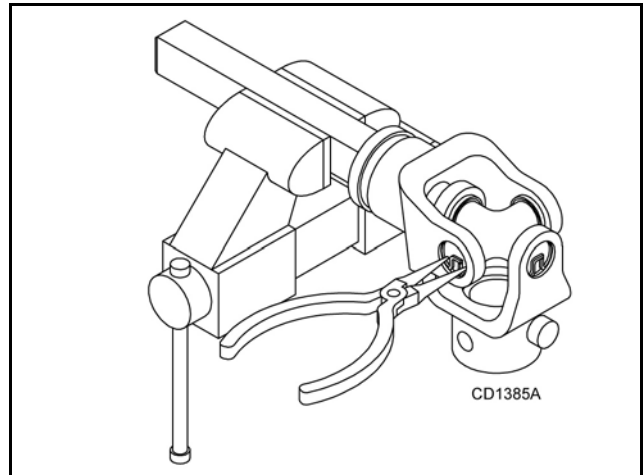

Figure 17

2. With snap rings removed, support drive in vise, hold yoke in hand and tap on yoke to drive cup up out of yoke. See Figure 18.

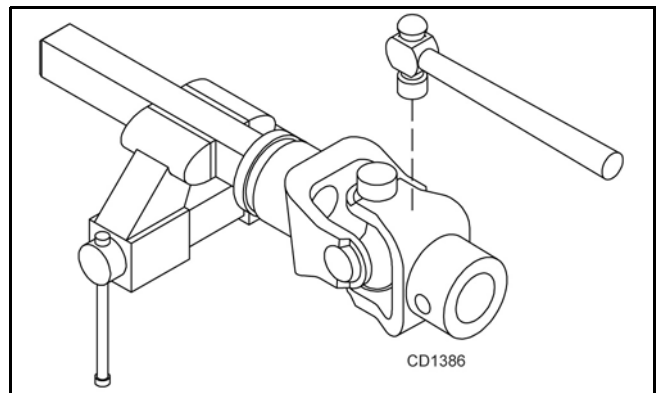

Figure 18

3. Clamp cup in vise as shown in Figure 19 and tap on yoke to completely remove cup from yoke. Repeat step 2 and step 3 for opposite cup.

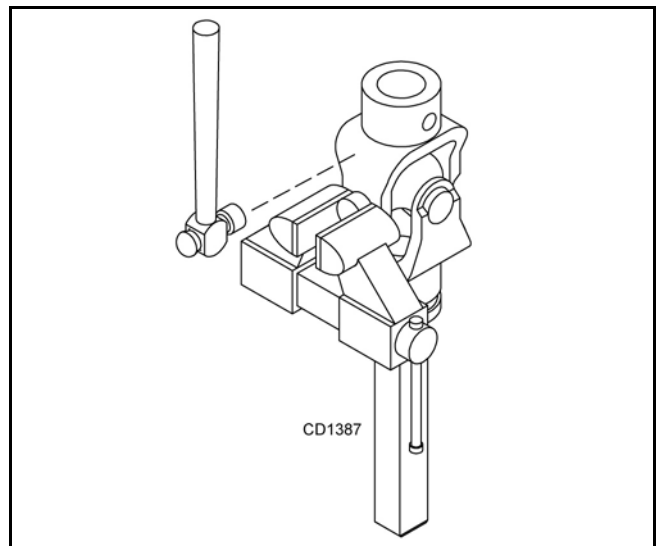

Figure 19

- Place universal cross in vise as shown in Figure 20 and tap on yoke to remove cup. Repeat Step 3 for final removal. Drive remaining cup out with a drift and hammer.

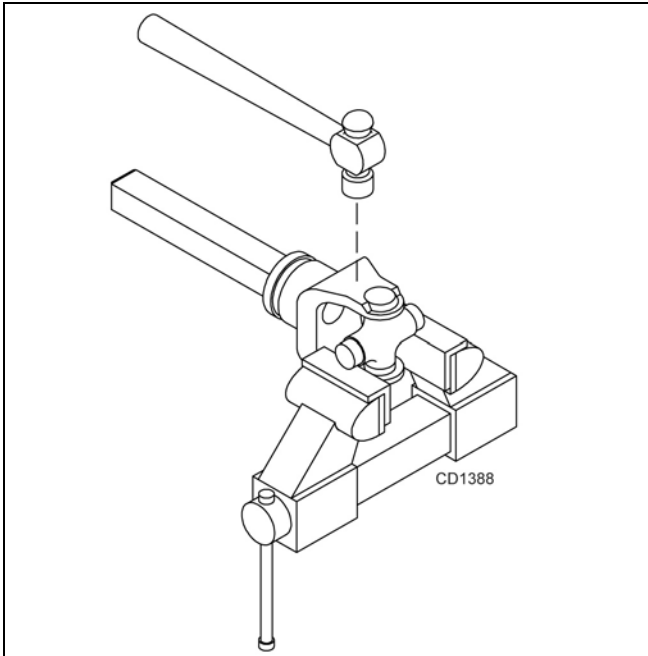

Figure 20

U-Joint Assembly

- Place seals securely on bearing cups. Insert cup into yoke from outside and press in with hand pressure as far as possible. Insert journal cross into bearing cup with grease fitting away from shaft. Be careful not to disturb needle bearings. Insert another bearing cup directly across from first cup and press in as far as possible with hand pressure.
- Trap cups in vise and apply pressure. Be sure journal cross is started into bearings and continue pressure with vise, squeezing in as far as possible. Tapping the yoke will help.
- Seat cups by placing a drift or socket (slightly smaller than the cup) on cup and rap with a hammer. Install snap ring and repeat on opposite cup.
- Repeat Step 1 and Step 2 to install remaining cups in remaining yoke.
- Move both yokes in all directions to check for free movement. If movement is restricted, rap on yokes sharply with a hammer to relieve any tension. Repeat until both yokes move in all directions without restriction.

SERVICING TIRES SAFELY

Used Aircraft Tires (Figure 21)

⚠ WARNING



■ Explosive separation of tire and rim parts can cause serious injury or death. Release all air pressure before loosening bolts.

Do not attempt to mount a tire unless you have the proper equipment and experience to perform the job.

Always maintain the correct tire pressure. Do not inflate tires above the recommended pressure. Never weld or heat a wheel and tire assembly. The heat can cause an increase in air pressure and result in a tire explosion. Welding can structurally weaken or deform the wheel.

When inflating tires, use a clip-on chuck and an extension hose long enough to allow you to stand to the side — not in front of or over the tire assembly. Use a safety cage if available.

Check wheels for low pressure, cuts, bubbles, damaged rims, or missing lug bolts and nuts.

Never remove split rim assembly hardware (A) with the tire inflated.



Figure 21. Split Rim Tire Servicing

ASSEMBLY INSTRUCTIONS

DEALER SET-UP INSTRUCTIONS

Assembly of this cutter is the responsibility of the WOODS dealer. It should be delivered to the owner completely assembled, lubricated and adjusted for normal cutting conditions.

The cutter is shipped partially assembled. Assembly will be easier if components are aligned and loosely assembled before tightening hardware. Recommended torque values for hardware are located on page 68.

Select a suitable working area. A smooth hard surface, such as concrete, will make assembly much quicker. Open parts boxes and lay out parts and hardware to make location easy. Refer to illustrations, accompanying text, parts lists and exploded view drawings.

Complete the check list on page 43 when assembly is complete and cutter is delivered to the customer.

WARNING

■ **Before working underneath, carefully read Operator's Manual instructions, disconnect driveline, raise mower, securely block up all corners with jackstands, and check stability. Secure blocking prevents equipment from dropping due to hydraulic leak down, hydraulic system failures, or mechanical component failures.**

■ **Do not disconnect hydraulic lines until machine is securely blocked or placed in lowest position and system pressure is released by operating valve levers.**

CAUTION

■ **Always wear relatively tight and belted clothing to avoid entanglement in moving parts. Wear sturdy, rough-soled work shoes and protective equipment for eyes, hair, hands, hearing, and head; and respirator or filter mask where appropriate.**

Fill Gearboxes

1. Remove top and side plugs from gearbox.

2. Fill gearbox with SAE 80W or 90W EP oil until it runs out of side level hole. Install plug in the side hole and vented dipstick in the top.

3. Allow oil to drain into the lower bearings and recheck oil level.

4. Fill all gearboxes.

Install Attitude Rod

1. Insert attitude rod (6) under splitter gearbox support and through pivot casting in wheel yoke arm assembly. The rod is a very tight fit; use care to prevent thread damage during installation.

2. Slide spacer (39) over rod and loosely install washer (52) and two nuts (54).

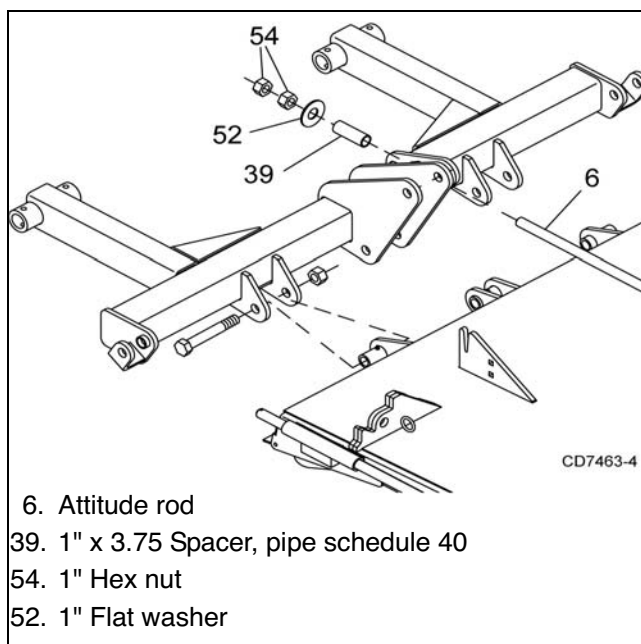

6. Attitude rod
39. 1" x 3.75 Spacer, pipe schedule 40
54. 1" Hex nut
52. 1" Flat washer

Figure 22. Attitude Rod Installed on Wheel Yoke Tube

Install Spring Arm

Refer to Figure 23.

1. Place spring arm (19), spacers (38), and spring (20) on deck as shown.

2. Secure spring arm and spacers to lugs on deck using clevis pin (33) and two cotter pins (80).

3. Install retaining cap screw (65) and flange lock nut (68).

Install Height Adjustment Cylinder

Refer to Figure 23.

1. Attach base end of cylinder (21) to the spring arm (19) using clevis pin (32) and two cotter pins (80).
2. Extend cylinder rod and place transport lock bracket (22) over cylinder rod clevis.
3. Position cylinder rod and transport lock bracket between lugs on the wheel yoke tube and align holes.
4. Secure cylinder rod and transport lock bracket to the wheel yoke tube using clevis pin (34) and two cotter pins (80).
5. Install bushing (40), elbow, (41) and hose (42) to the base end of cylinder (21). See Install Hose Kit, page 39 for complete instructions.

NOTE: An optional ratchet (24) is available, and replaces the hydraulic cylinder. Install ratchet jack using the same procedure and hardware used for the installation of the hydraulic cylinder.

Install SMV Emblem

Refer to Figure 23.

1. Attach SMV mounting bracket (25) to left side of center section as shown using two carriage bolts (66) and flange lock nuts (68).
2. Attach SMV socket (26) to mounting bracket (25) using two carriage bolts (73) and lock nuts (77).
3. Attach SMV emblem (28) to SMV bracket (27) using two round head cap screws (78) and hex nuts (79).

Insert SMV bracket (27) and emblem (28) into socket (26).

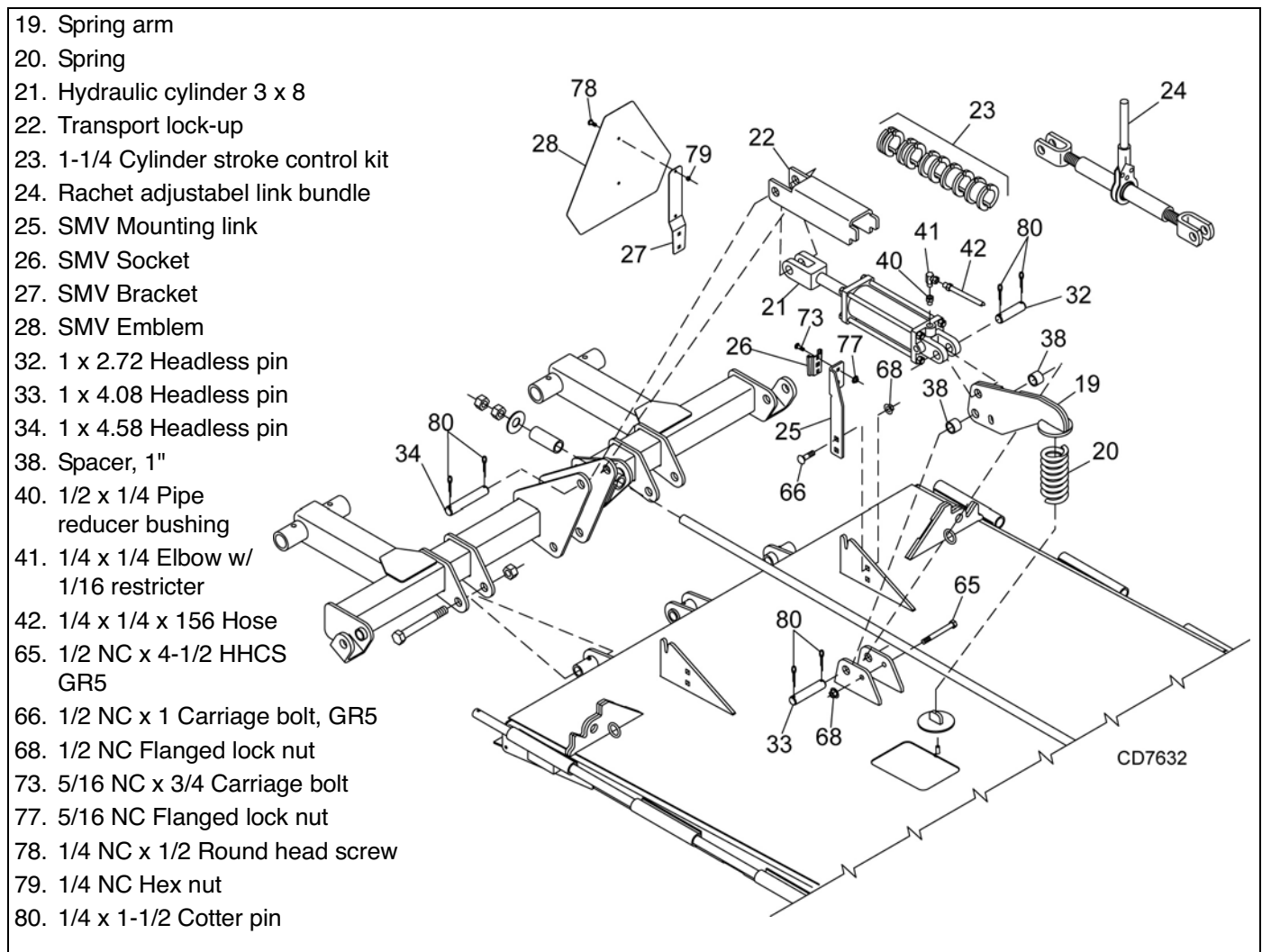

Figure 23. Spring Arm and Cylinder Installation

Install Wheel and Hub

1. Insert wheel hub into outside of wheel yoke arm (17) and align holes.
2. Secure into position using cap screw (64) and flanged lock nut (68).
3. Attach wheel to hub using five lug nuts. Install the chamfered side of the lug nut toward the inside for steel rim for pneumatic tires and rims. Tighten to 75 lbs-ft. Check that tire air pressure is a maximum of 40 psi.

NOTE: Install the flat side of the nut toward the inside for solid tires and aircraft tires (shown).

4. Install optional dual wheel and hub to inside of wheel yoke arm.

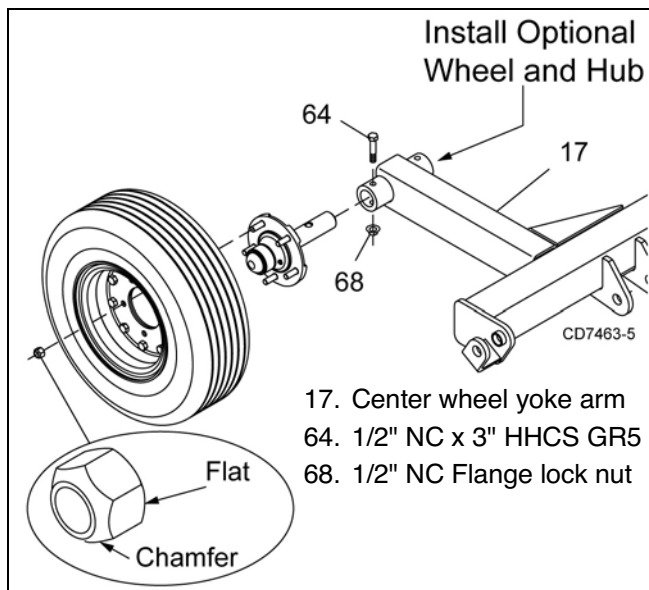
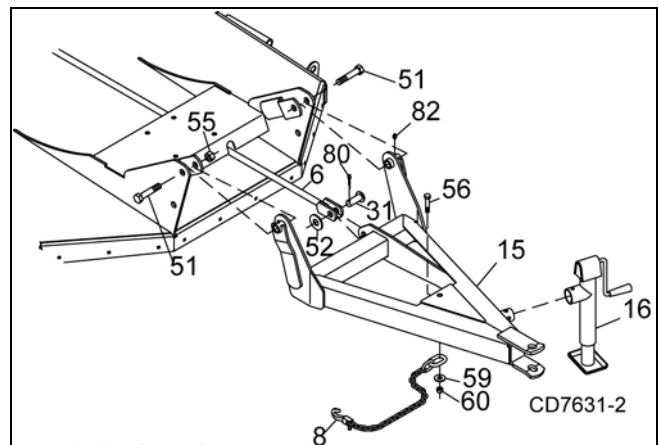

Figure 24. Center Section Wheel and Hub Installation

Install Tongue

1. Attach tongue (15) to center section using two cap screws (51) and lock nuts (55).
2. Attach attitude rod (6) to lug on tongue and secure with clevis pin (31), washer (52), and cotter pin (80).
3. Attach parking jack (16) to the side of the tongue.
4. Attach safety chain (8) to the bottom of center gusset and secure with cap screw (56), washer (59), and lock nut (60).



6. Attitude rod
 8. Safety chain
 15. Tongue
 16. Parking jack
 31. Clevis pin, 1" x 2.26"
 51. 1" NC x 4-1/2" HHCS GR5
 52. Washer, flat 1"
 55. 1" NC Lock nut
 56. 3/4" NC x 2-1/4" HHCS GR5
 59. Washer, flat 3/4" x 2" x 3/8"
 60. 3/4" NC Lock nut
 80. Cotter pin, 1/4" x 1-1/2"

Figure 25. Tongue Installation

Install CV Drive

1. Align hole in drive yoke with groove on gearbox input shaft and slide rear half of drive (5) onto shaft.
2. Secure with bolt and nut supplied with drive.

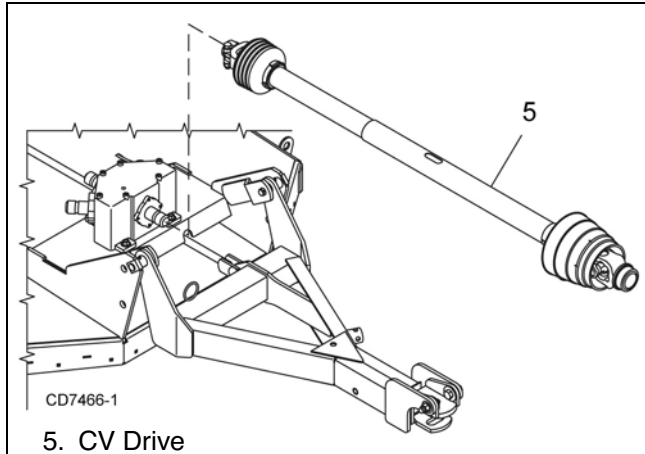

Figure 26. CV Drive Installation

Install Wing

CAUTION

■ Use a suitable lifting device of sufficient capacity. Use adequate personnel to handle heavy components.

The wing must be installed in the following sequence and will require at least two people. A floor jack or a suitable lifting device will be helpful to align decks when installing the hinge pin.

1. Attach winglet (7) to wing using three carriage bolts (69) and flange lock nuts (70).
2. Remove hinge pin (11) from center section.
3. Place wing assembly adjacent to the center section and align hinge sections.
4. Insert hinge pin through the hinge sections and secure with spring pin (81) and washer (52) on both ends.
5. Attach side skid (6) to the wing using four carriage bolts (66) and flange lock nuts (68).
6. Repeat procedure of opposite wing.

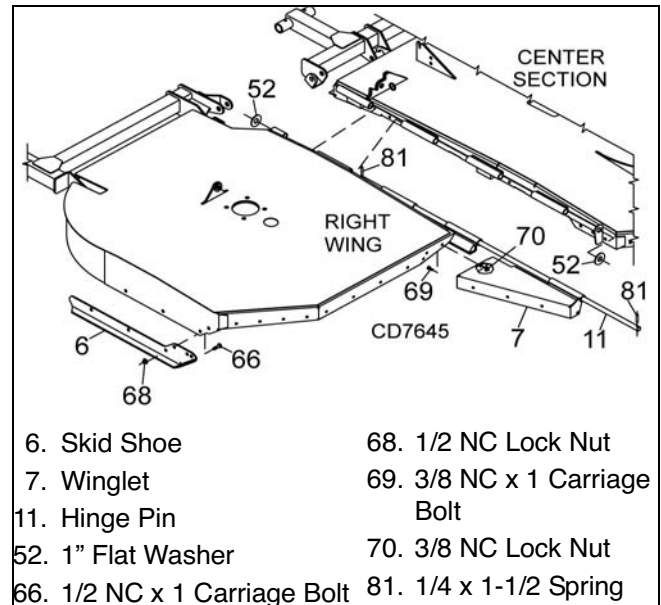

Figure 27. Right Wing Installation

Install Wing Cylinder & Lock-up Bar

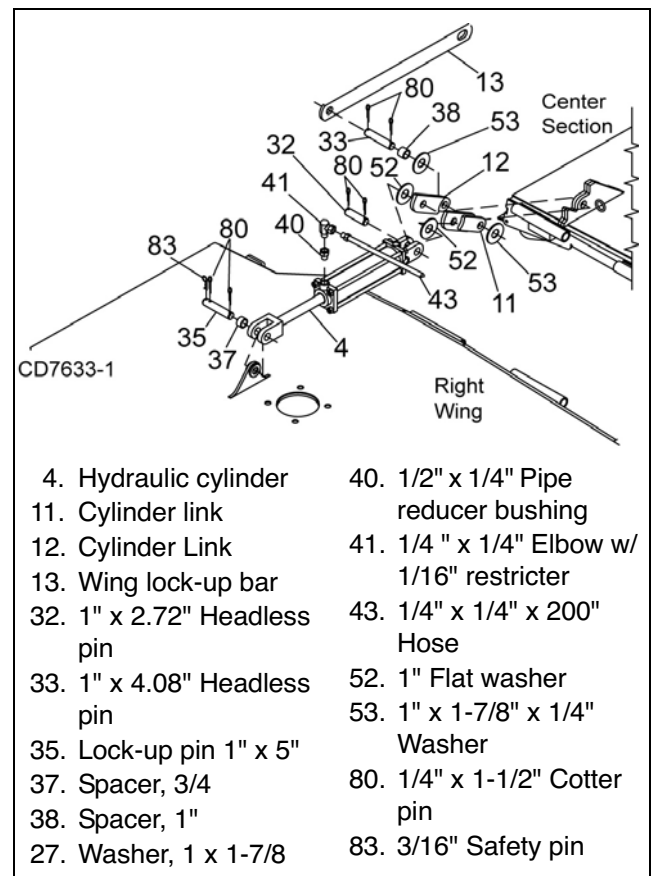
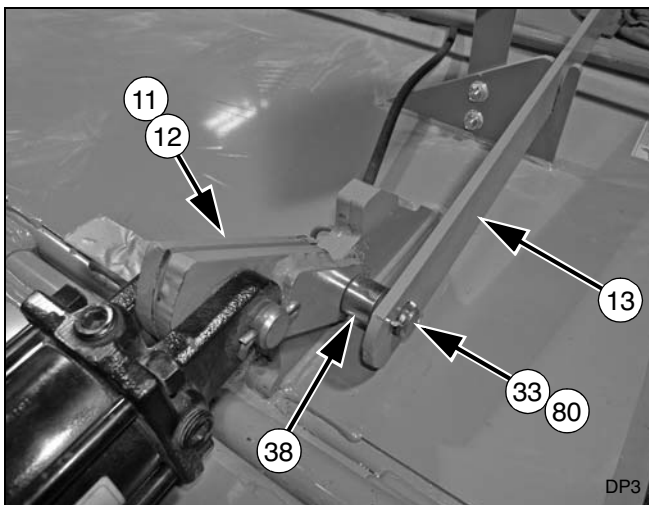

Figure 28. Wing Cylinder & Lock-Up Bar Installation

1. Place two cylinder links (11 & 12) on either side of cylinder lug on center section as shown, align holes and insert clevis pin (33).

NOTE: Items 11 & 12 must be installed with square corners on top and facing cylinder as shown.

2. Slide spacer (38) and lock-up bar (13) over clevis pin (33) on back side of cylinder lug & secure with 1"x1-7/8" washers (53) and cotter pins (80).
3. Attach base end of wing cylinder (4) to cylinder links (11 & 12) and washers (52) using clevis pin (32) and cotter pins (80).
4. Remove plug from base end of hydraulic cylinder. Align cylinder rod end with cylinder lug on the wing and insert lock-up pin (35).
5. Slide spacer (37) over lock-up pin (35) on back side of cylinder rod and secure with cotter pins (80).
6. Insert safety pin (83) into the end of lock-up pin (35). The safety pin will secure lock-up bar into position when wing is in the UP position.
7. Extend cylinder fully & replace plug in base end of cylinder. This trapped air will help push wing down.
8. Install bushing (40), elbow, (41) and hose (43) to the rod end of cylinder (4). See Install Hose Kit, page 39 for complete instructions.
9. Repeat procedure for opposite wing.



- | | |
|------------------------------|-----------------|
| 11. Cylinder link | 38. Spacer, 1" |
| 12. Cylinder link | 80. Cotter pin, |
| 13. Wing lock-up bar | 1/4" x 1-1/2" |
| 33. Headless pin, 1" x 4.08" | |

Figure 29. Left Wing Lock-Up Bar Installed

Install Wing Wheel and Hub (Figure 30)

1. Insert wheel hub into wing wheel yoke arms (5) and align holes.
 2. Secure into position using cap screw (64) and flanged lock nut (68).
 3. Attach wheel to hub using five lug nuts. Install the chamfered side of the lug nut toward the inside for steel rim for pneumatic tires and rims. Tighten to 75 lbs-ft. Check that tire air pressure is a maximum of 40 psi.
- NOTE:** Install the flat side of the nut toward the inside for solid tires and aircraft tires (shown).
4. Install optional dual wheel and hub to inside of wheel yoke arm.

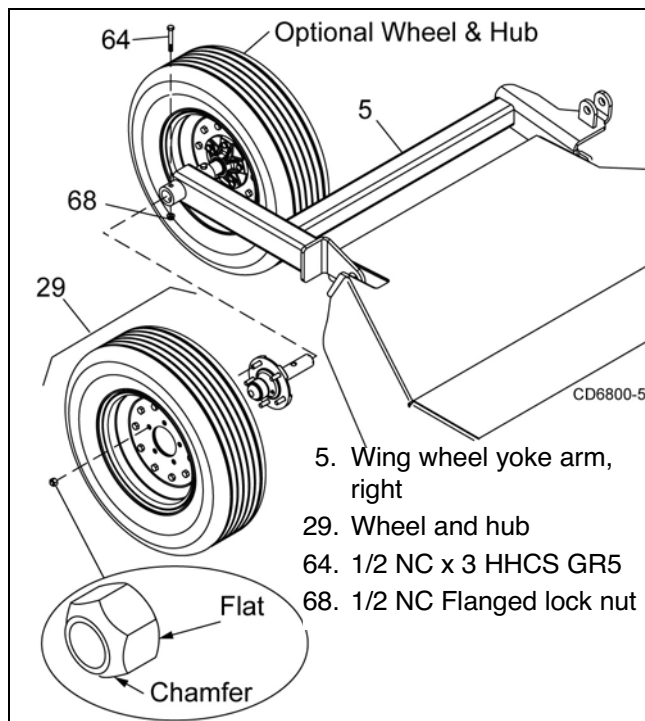

Figure 30. Wing Wheel and Hub Installation - Right

5. Wing wheel yoke arm, right
29. Wheel and hub
64. 1/2 NC x 3 HHCS GR5
68. 1/2 NC Flanged lock nut

Install Wing Wheel Yoke Adjustment Link

CAUTION

■ Use a suitable lifting device of sufficient capacity. Use adequate personnel to handle heavy components.

1. With a lifting device raise right wing and lock in the up position using the wing lock-up bar. Leave lifting device attached for added support.
2. Attach adjustable link (30) to right side of center wheel yoke arm and secure with cap screw (51) and lock nut (55).
3. Attach opposite end of adjustable link (30) to wing wheel yoke arm and secure with cap screw (51) and lock nut (55).
4. Remove lock-up bar and carefully lower wing using lifting device.
5. Repeat process for left wing.

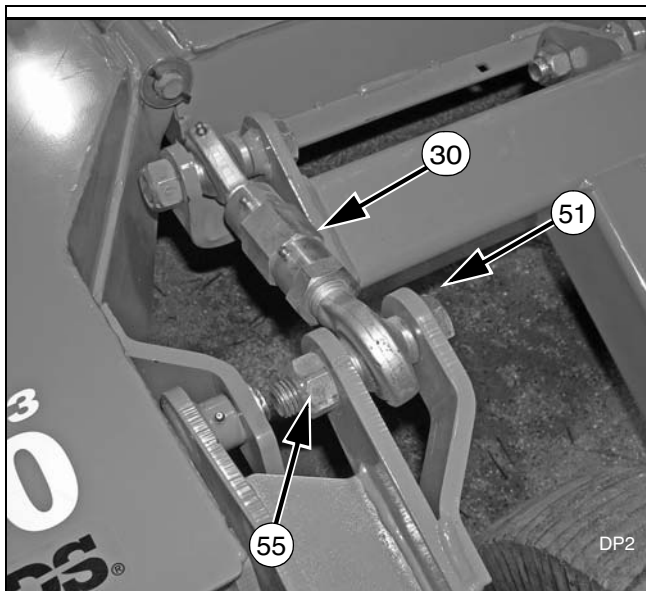

- 30. Adjustable link
- 51. 1 NC x 4-1/2 HHCS GR5
- 55. 1 NC Lock nut

Figure 31. Left Wing Wheel Yoke Adjustment Link Installed

Install Wing Driveline

1. Attach clutch shield (8) to wing gearbox using four cap screws (84), lock washers (75), and flat washers (74).
2. Slide non clutch end of driveline (3) over wing gearbox shaft. Make sure the lock collar engages securely.
3. Slide clutch end of driveline over splitter gearbox and secure using cap screws and lock nuts supplied with driveline.
4. Repeat process for left driveline.

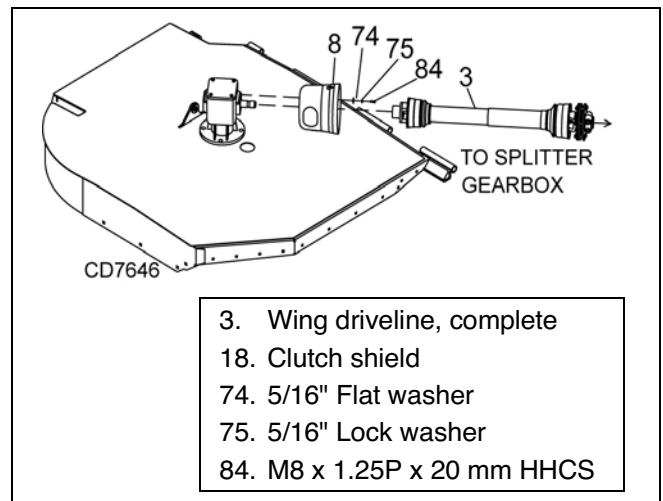

Figure 32. Right Driveline Installation

Install Hose Kit

1. Remove plug from rod end of each wing cylinder.
2. With the wings in the down position and cylinder extended, remove and reinstall the plugs from the base of the wing cylinders. This will trap air behind the piston and help when lowering the wings.
3. Install reducer bushing and restricter elbow into cylinders. Position elbow on center cylinder to point forward; on wing cylinders point elbows to the center.
NOTE: Make sure a breather fitting is installed in the rod end port of the wheel yoke cylinder.
4. Attach hose to each elbow.

Install Chain or Belt Shielding

! DANGER

■ Full chain shielding must be installed when operating in populated areas or other areas where thrown objects could injure people or damage property.

- If this machine is not equipped with full chain shielding, operation must be stopped when anyone comes within 300 feet (92 m).
- This shielding is designed to reduce the risk of thrown objects. The mower deck and protec-

tive devices cannot prevent all objects from escaping the blade enclosure in every mowing condition. It is possible for objects to ricochet and escape, traveling as much as 300 feet (92 m).

Install chain and rubber shields with hardware as shown. (Refer to Figure 33 for Chain Shielding Installation; Figure 35 and Figure 36 for Belt Shielding Installation.)

NOTE: Chain Shielding: Install four (two per wing) 4-link chain sections (16) to the wing skid shoes. Secure with carriage bolts (19) and flange lock nuts (21).

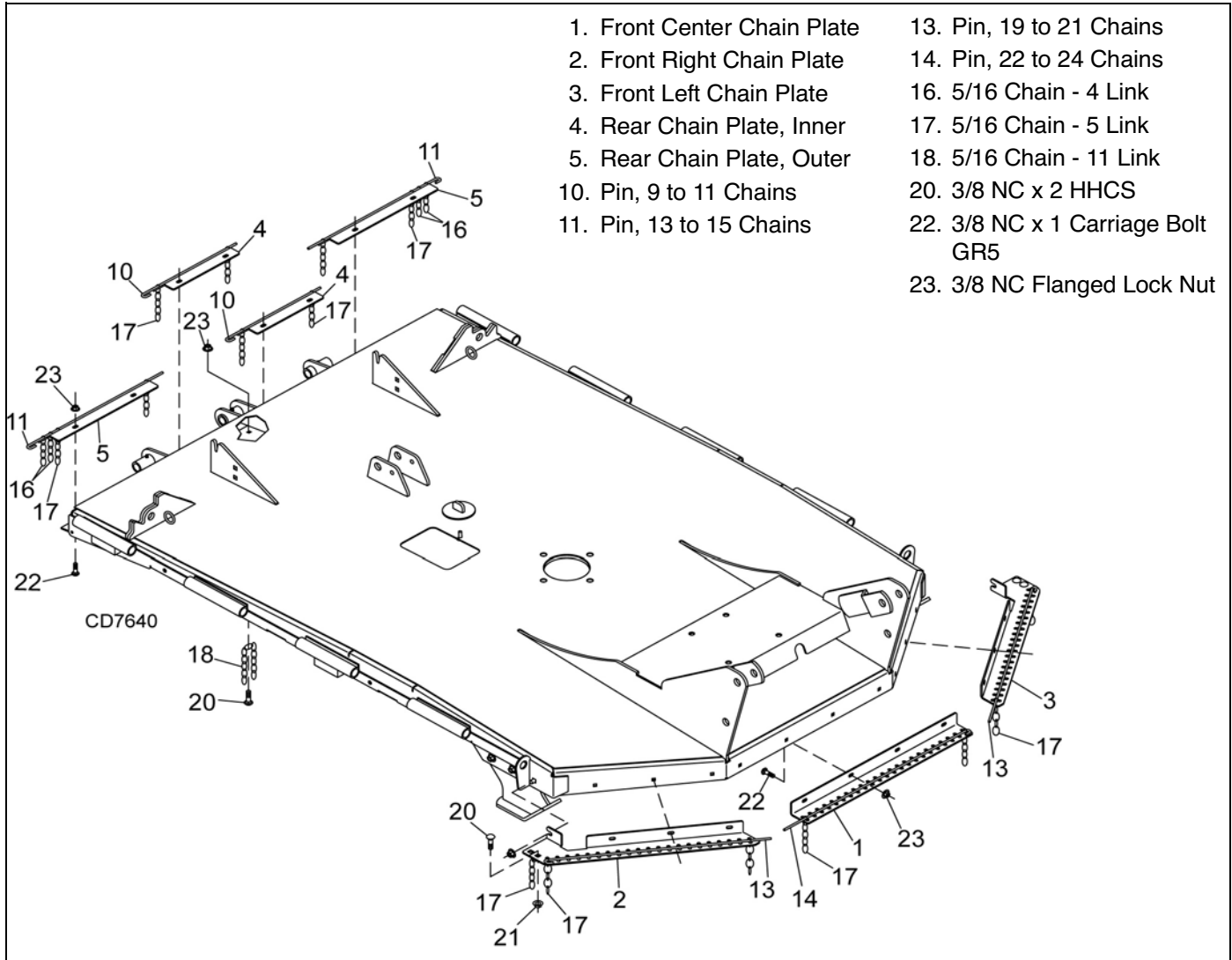
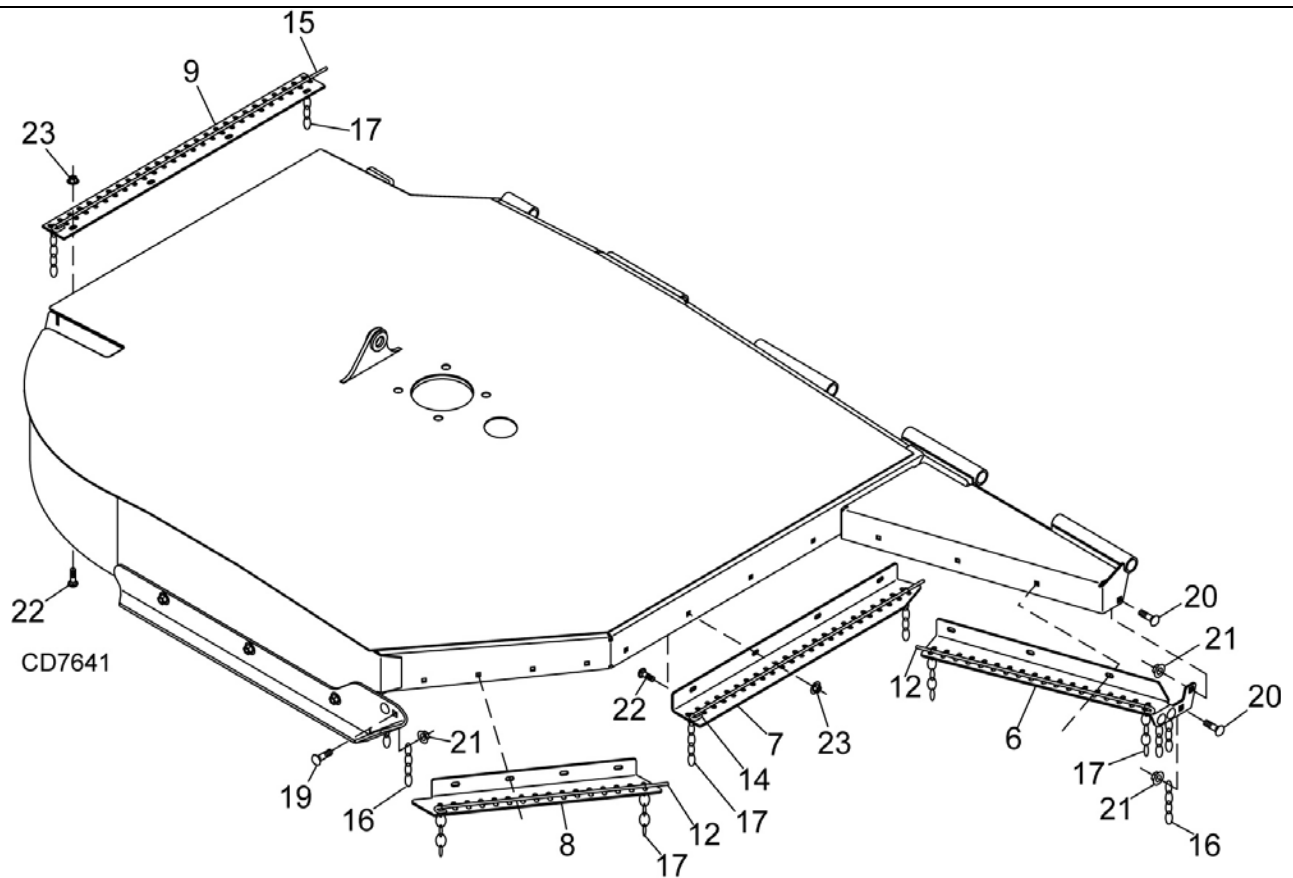

Figure 33. Chain Shielding Installation - Center Section



- | | | |
|---|---------------------------------------|------------------------------|
| 6. Front right wing chain plate, inner - or- | 8. Front left wing chain plate, outer | 21. 1/2 NC Flanged Lock Nut |
| 6. Front left wing chain plate, inner | 9. Rear wing chain plate | 22. 3/8 NC X 1 Carriage Bolt |
| 7. Front right wing chain plate, middle - or- | 12. Pin, 16 to 18 chains | 23. 3/8 NC Flanged Lock Nut |
| 7. Front left wing chain plate, middle | 14. Pin, 22 to 24 chains | |
| 8. Front right wing chain plate, outer -or- | 15. Pin, 25 to 27 chains | |
| | 16. 5/16 Chain - 4 link | |
| | 17. 5/16 Chain - 5 link | |
| | 19. 1/2 NC X 1-1/2 Carriage Bolt | |
| | 20. 1/2 NC X 1 Carriage Bolt | |

Figure 34. Chain Shielding Installation - Right Wing Shown

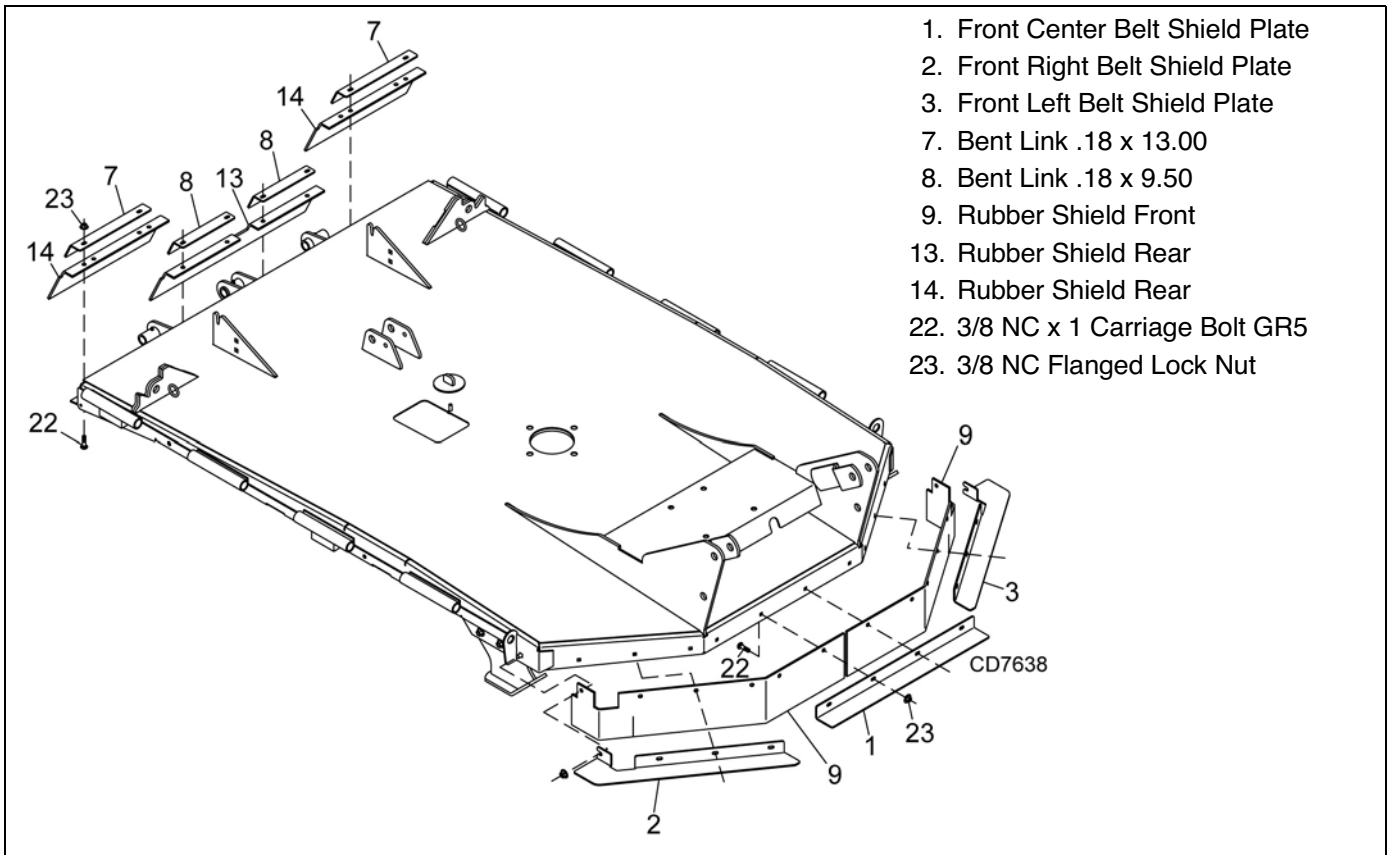

Figure 35. Belt Shielding Installation - Center Section

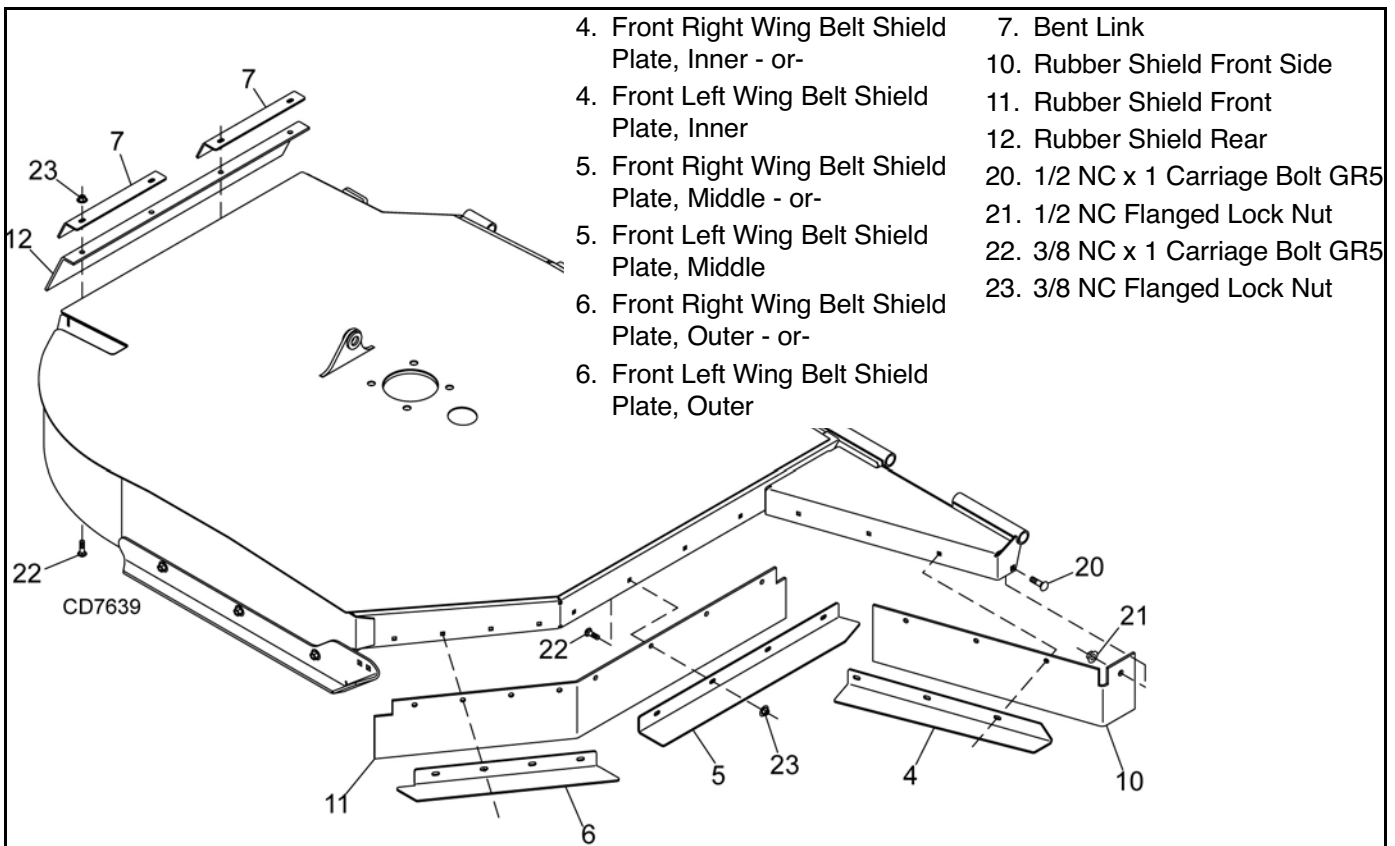

Figure 36. Belt Shielding Installation - Right Wing

DEALER CHECK LISTS

PRE-DELIVERY CHECK LIST

(DEALER'S RESPONSIBILITY)

Inspect the equipment thoroughly after assembly to ensure it is set up properly before delivering it to the customer.

The following check lists are a reminder of points to inspect. Check off each item as it is found satisfactory or after proper adjustment is made.

NOTICE

■ **Gearboxes are not filled at the factory. Prior to delivery, make sure each gearbox is filled between lowest ring and end of dipstick with 80 or 90W API GL-4 or GL-5 gear lube.**

- ___ Check that all safety decals are installed and in good condition. Replace if damaged.
- ___ Check that shields and guards are properly installed and in good condition. Replace if damaged.
- ___ Check all bolts to be sure they are properly torqued.
- ___ Check wheel bolts for proper torque.
- ___ Check that all cotter pins and safety pins are properly installed. Replace if damaged.
- ___ Check that blades have been properly installed.
- ___ Check and grease all lubrication points as identified in lubrication information on page 20.
- ___ Check the level of gearbox fluids before delivery. Service, if required, as specified in the lubrication information on page 20.

DELIVERY CHECK LIST

(DEALER'S RESPONSIBILITY)

- ___ Show customer how to make adjustments and select proper PTO speed.
- ___ Show customer how to make sure driveline is properly installed and that spring-activated locking pin or collar slides freely and is seated in groove on tractor PTO shaft.

- ___ Show customer how to determine the turning limits of the CV PTO driveline.
- ___ Show customer the safe, proper procedures to be used when mounting, dismounting, and storing equipment.
- ___ Make customer aware of optional equipment available so that customer can make proper choices as required.
- ___ Instruct customer how to lubricate and explain importance of lubrication.
- ___ Point out the safety decals. Explain their meaning and the need to keep them in place and in good condition. Emphasize the increased safety hazards when instructions are not followed.
- ___ Explain to customer that when transporting the cutter, the wing and center sections should be raised and their respective transport bars installed and pinned in place.
- ___ Present Operator's Manual and request that customer and all operators read it before operating equipment. Point out the manual safety rules, explain their meanings and emphasize the increased safety hazards that exist when safety rules are not followed.
- ___ Explain to customer the potential crushing hazards of going underneath raised equipment. Instruct that before going underneath to disconnect the driveline, securely block up all corners with jack stands and to follow all instructions in the BLOCKING METHOD, page 19 of the operator's manual. Explain that blocking up prevents equipment dropping from hydraulic leak down, hydraulic system failures or mechanical component failures.
- ___ Point out all guards and shields. Explain their importance and the safety hazards that exist when not kept in place and in good condition.
- ___ Explain to customer that when towing on a public road to comply with all state and local lighting/marketing laws and to use a safety tow chain.

NOTES

BATWING® Rotary Cutter **BW15LH**

MAIN FRAME ASSEMBLY	(FRONT SECTION)	46-47
	(REAR SECTION)	48-49
WING ASSEMBLY		50-51
GEARBOX ASSEMBLY	SPLITTER	52-53
	WING & CENTER	54-55
DRIVE ASSEMBLY	CENTER DECK	56
	CV DRIVE	57
	WING (WALTERSCHEID).....	58
	WING (BONDIOLI & PAVESI).....	59
WHEEL & TIRE ASSEMBLY	5-BOLT	60
SHIELDING	RUBBER SHIELDING - CENTER SECTION	61
	RUBBER SHIELDING - WING	62
	CHAIN SHIELDING - CENTER SECTION (OPTIONAL)	63
	CHAIN SHIELDING - WING (OPTIONAL)	64
HYDRAULIC CYLINDERS		65
HYDRAULIC CYLINDER STROKE CONTROL KIT		66
CROSSBAR PULLER (OPTIONAL)		66
WINCH KIT (OPTIONAL)		67

MAIN FRAME ASSEMBLY (FRONT SECTION)

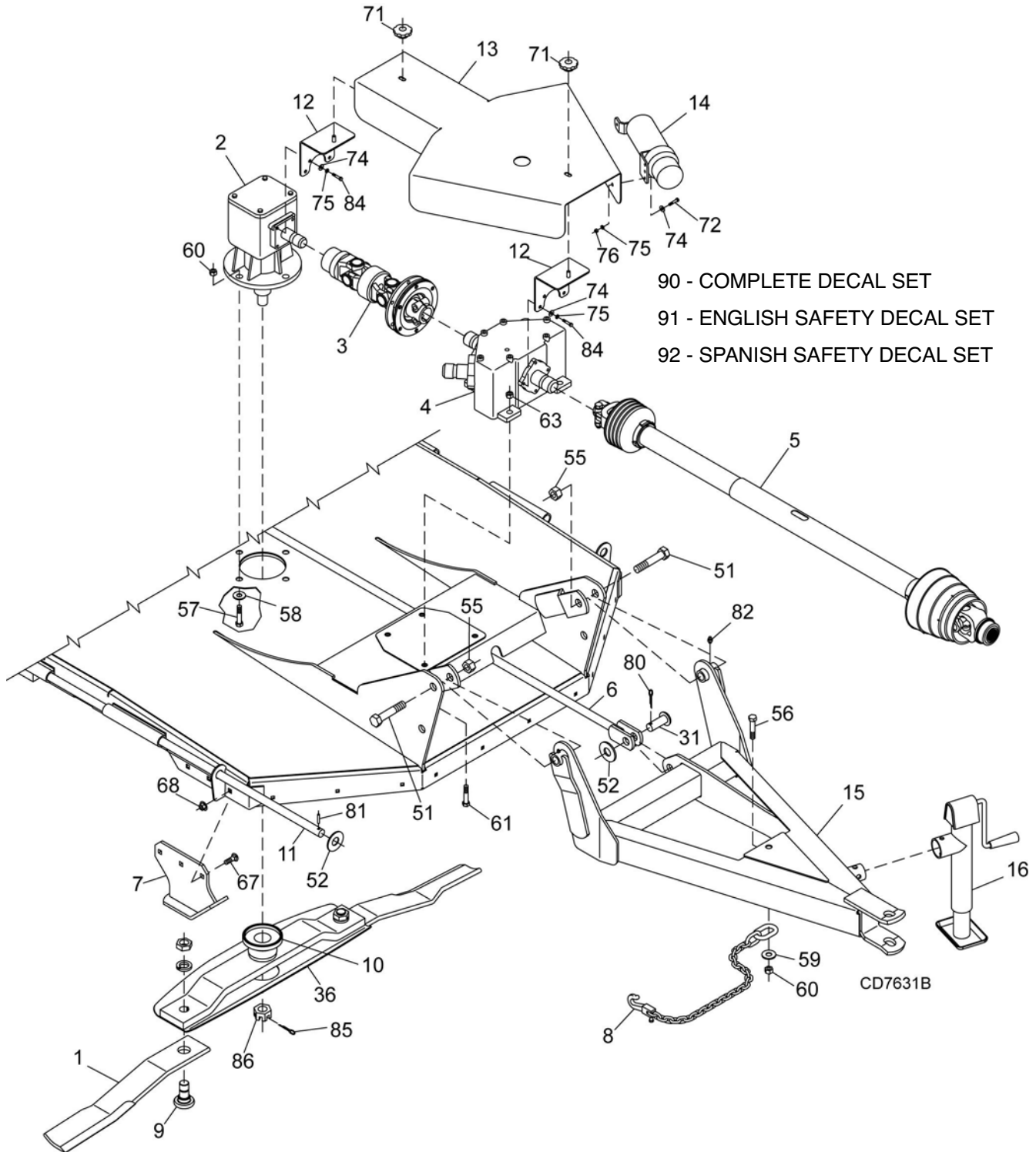

46 Parts

(Rev. 9/11/2013)
MAN0810 (9/24/2009)

MAIN FRAME ASSEMBLY (FRONT SECTION)

REF	PART	QTY	DESCRIPTION	REF	PART	QTY	DESCRIPTION
1	19160KT	1	Blade kit, CCW	58	57798		3/4" Hardened flat washer
2	1032298	1	Gearbox (see page 54)	59	8424		3/4" x 2" x 3/8" Flat wasger
3	1032185	1	Driveline complete, 1340, 1.75-20.8 w/ clutch (see page 56)	60	2371	*	3/4" NC Lock nut
4	1003687	1	Splitter gearbox (see page 52)	61	902	*	5/8" NC x 2" HHCS GR5
5	1032189	1	CV drive (see page 57)	63	19024	*	5/8" NC Flanged lock nut
6	1003491	1	Attitude rod	67	2615	*	1/2" NC x 1-1/4 Carriage bolt, GR5
7	1032238	2	Front skid	68	11900	*	1/2" NC Flanged lock nut
8	19407	1	Safety chain	71	66840		3/8" NC 3-Prong knob
9	57093	2	Blade pin (includes washer & nut)	72	14562	*	5/16" NC x 1" HHCS GR5
10	1032147	1	Crossbar Assembly	74	35155	*	5/16" SAE Flat washer
11	1003495	2	Hinge pin	75	2472	*	5/16" Lock washer
12	1032221	2	Shield standoff	76	4529	*	5/16" NC Hex nut ZP
13	1032220	1	Shield	80	1285	*	1/4" x 1-1/2" Cotter pin
14	1003828	1	Manual tube	81	66016	*	1/4" x 1-1/2" Spring pin
15	1032190	1	Tongue	82	12296	*	1/4-28 Grease fitting
16	23790	1	Parking jack	84	39254	*	M8 x 1.25P x 14mm HHCS
31	46605	1	Clevis pin, 1" x 2.26"	85	-----	*	B6 x 60 Cotter pin
36	1032265	1	Stump jumper pan	86	39323	*	M30 x 2.0P Castle nut
51	46752		1" NC x 4-1/2" HHCS GR5	90	1003689		Complete decal set
52	1863	*	1" Flat washer	91	1003679		English safety decal set
55	34279	*	1" NC Lock nut	92	1036791		Spanish safety decal set
56	13759		3/4" NC x 2-1/4" HHCS GR5				
57	30068	*	3/4" NC x 2-1/2" HHCS GR5				

HHCS Hex Head Cap Screw

* Standard hardware, obtain locally

MAIN FRAME ASSEMBLY (REAR SECTION)

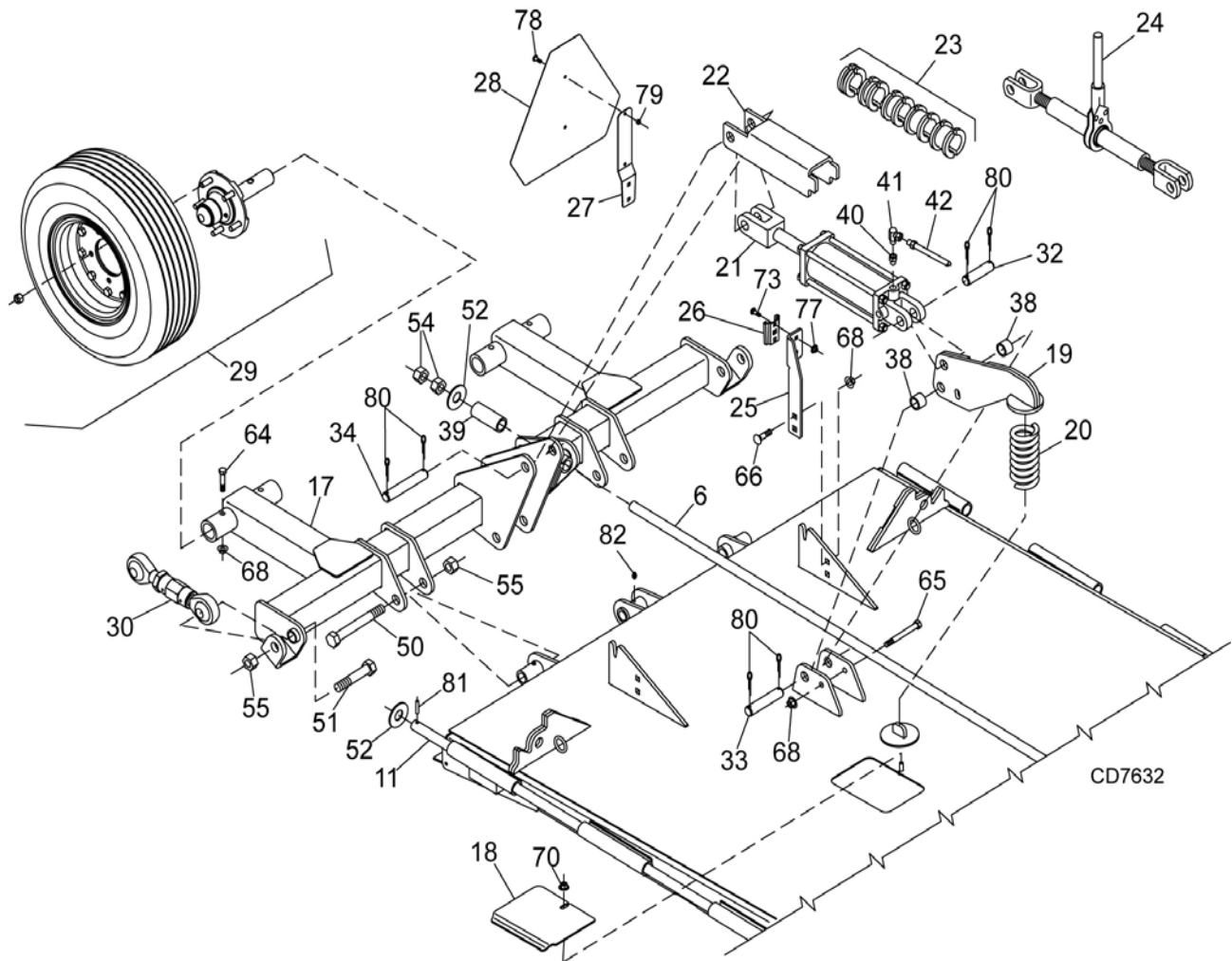

48 Parts

MAN0810 (9/24/2009)

MAIN FRAME ASSEMBLY (REAR SECTION)

REF	PART	QTY	DESCRIPTION	REF	PART	QTY	DESCRIPTION
6	1003491	1	Attitude rod	40	11893	1	1/2 x 1/4 Pipe reducer bushing
11	1003495	2	Hinge pin	41	10290	1	1/4 x 1/4 Elbow w/ 1/16 restricter
17	1032200	1	Center wheel yoke	42	8669	1	1/4 x 1/4 x 156 Hose
18	57050	1	Access hole cover	50	1003606	*	1 NC x 6 HHCS GR5
19	1032225	1	Spring arm	51	46752	1	NC x 4-1/2 HHCS GR5
20	13316	1	Spring	52	1863	*	1" Flat washer
21	29547	1	Hydraulic cylinder 3 x 8 (see page 64)	54	3132	*	1 NC Hex nut
22	1004814	1	Transport lock-up	55	34279	*	1 NC Lock nut
23	24098	1	1-1/4 Cylinder stroke control kit	64	3489	*	1/2 NC x 3 HHCS GR5
24	23650	1	Ratchet adjustable link bundle(optional)	65	3508	1	1/2 NC x 4-1/2 HHCS GR5
25	1017143	1	SMV Mounting link	66	14406	*	1/2 NC x 1 Carriage bolt, GR5
26	62484	1	SMV Socket	68	11900	*	1/2 NC Flanged lock nut
27	1004251	1	SMV Bracket	70	14350	*	3/8 NC Flanged lock nut
28	24611	1	SMV Emblem	73	16148	5/16	NC x 3/4 Carriage bolt
29	-----	2	Tire & hub (see page 59)	77	14139	*	5/16 NC Flanged lock nut
30	1003690	2	Adjustable link	78	1282	*	1/4 NC x 1/2 Round head screw
32	1631	1	1 x 2.72 Headless pin	79	5288	*	1/4 NC Hex nut
33	8345	1	1 x 4.08 Headless pin	80	1285	*	1/4 x 1-1/2 Cotter pin
34	8346	1	1 x 4.58 Headless pin	81	66016	*	1/4 x 1-1/2 Spring pin
38	65130	2	Spacer, 1"	82	12296	*	1/4-28 Grease fitting
39	27267	1	Pipe, 1" Schedule 40 x 3.75"		HHCS		Hex Head Cap Screw

* Standard hardware, obtain locally

WING ASSEMBLY

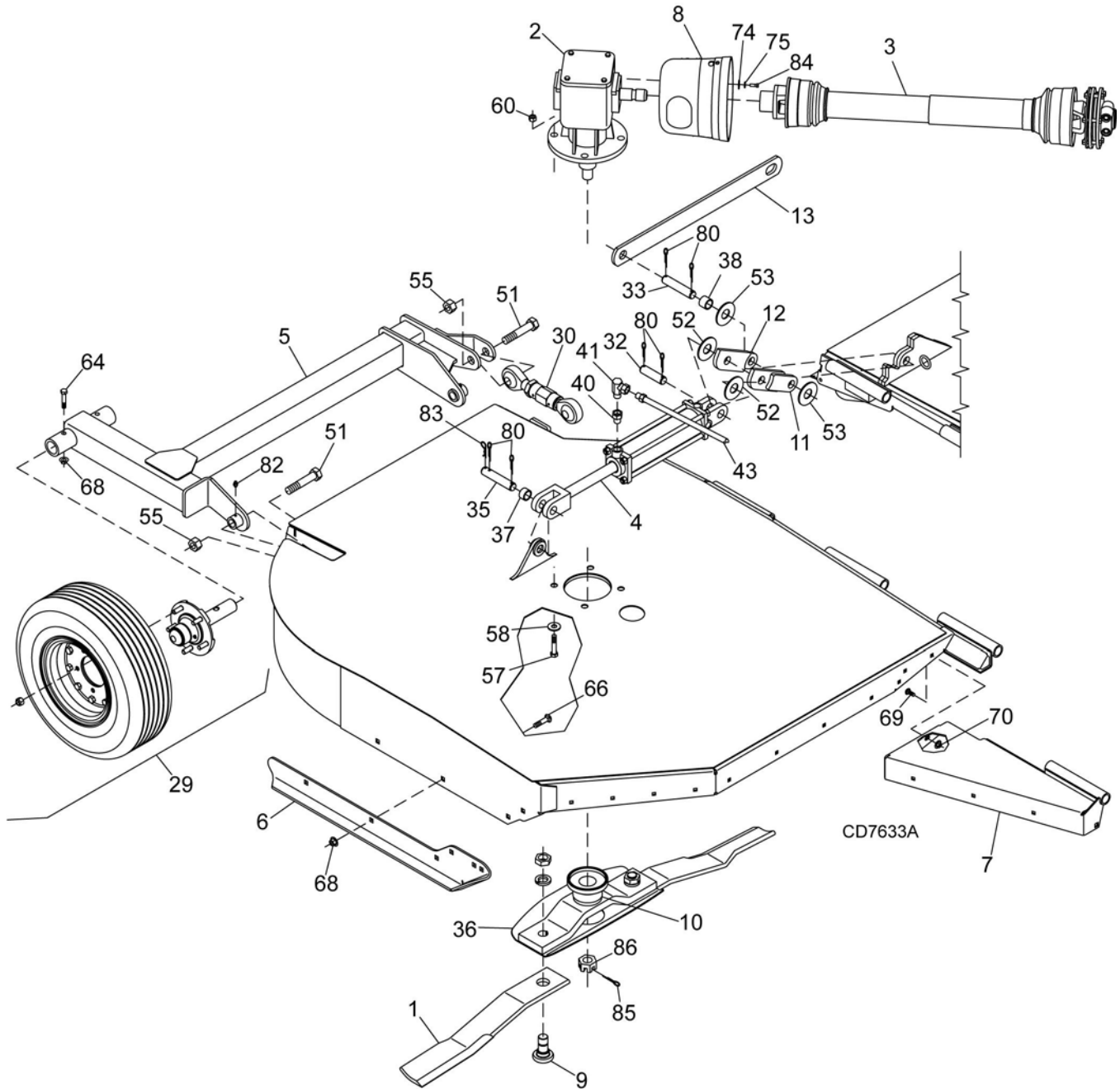

50 Parts

(Rev. 3/3/2010)

MAN0810 (9/24/2009)

WING ASSEMBLY

REF	PART	QTY	DESCRIPTION	REF	PART	QTY	DESCRIPTION
1	19160KT	1	Blade kit, CCW (Right wing) - or -	38	65130	2	Spacer, 1"
1	19161KT	1	Blade kit, CW (Left wing)	40	11893	1	1/2 x 1/4 Pipe reducer bushing
2	1032297	1	Gearbox (Right wing, see page 54) - or -	41	10290	1	1/4 x 1/4 Elbow w/ 1/16 restricter
2	1032298	1	Gearbox (Left wing, see page 54)	43	14552	1	1/4 x 1/4 x 200 Hose
3	1032186	1	Driveline complete 1240, 49.6 x 71.3(see page 58 and 59)	51	46752	1	NC x 4-1/2 HHCS GR5
4	1031166	1	Hydraulic cylinder 3 x 10 (see page 64)	52	1863	*	1" Flat washer
5	1032210	1	Wing wheel yoke (Right wing) - or -	53	11920		1 x 1-7/8 x 1/4 Washer
5	1032211	1	Wing wheel yoke (Left wing)	55	34279	*	1 NC Lock nut
6	1032180	1	Side skid (Right wing) - or -	57	30068	*	3/4 NC x 2-1/2 HHCS GR5
6	1032181	1	Side skid (Left wing)	58	57798		3/4 Hardened flat washer
7	1032230	1	Winglet (Right wing) - or -	60	2371	*	3/4 NC Lock nut
7	1032231	1	Winglet (Left wing)	64	3489	*	1/2 NC x 3 HHCS GR5
8	1002048	1	Clutch shield	66	14406	*	1/2 NC x 1 Carriage bolt, GR5
9	57093	2	Blade pin (includes washer & nut)	68	11900	*	1/2 NC Flanged lock nut
10	1032178	1	Crossbar Assembly	69	6697	*	3/8 NC x 1 Carriage bolt, GR5
11	1032254	1	Cylinder link	70	14350	*	3/8 NC Flanged lock nut
12	1032255	1	Cylinder link	74	35155	*	5/16 SAE Flat washer
13	1003498	1	Wing lock-up bar	75	2472	*	5/16 Lock washer
29	-----	2	Tire & hub (see page 59)	80	1285	*	1/4 x 1-1/2 Cotter pin
30	1003690	2	Adjustable link	82	12296	*	1/4-28 Grease fitting
32	1631	1	1 x 2.72 Headless pin	83	18270	*	3/16 Safety pin
33	8345	1	1 x 4.08 Headless pin	84	39254	*	M8 x 1.25P x 14 mm HHCS
35	32469	1	1 x 5 Lock-up pin	85	-----	*	B6 x 60 Cotter pin
36	1032266	1	Stump jumper pan	86	39323		M30 x 2.0P Castle nut
37	33647	1	Spacer, 3/4"		HHCS		Hex Head Cap Screw
						*	Standard hardware, obtain locally

SPLITTER GEARBOX ASSEMBLY

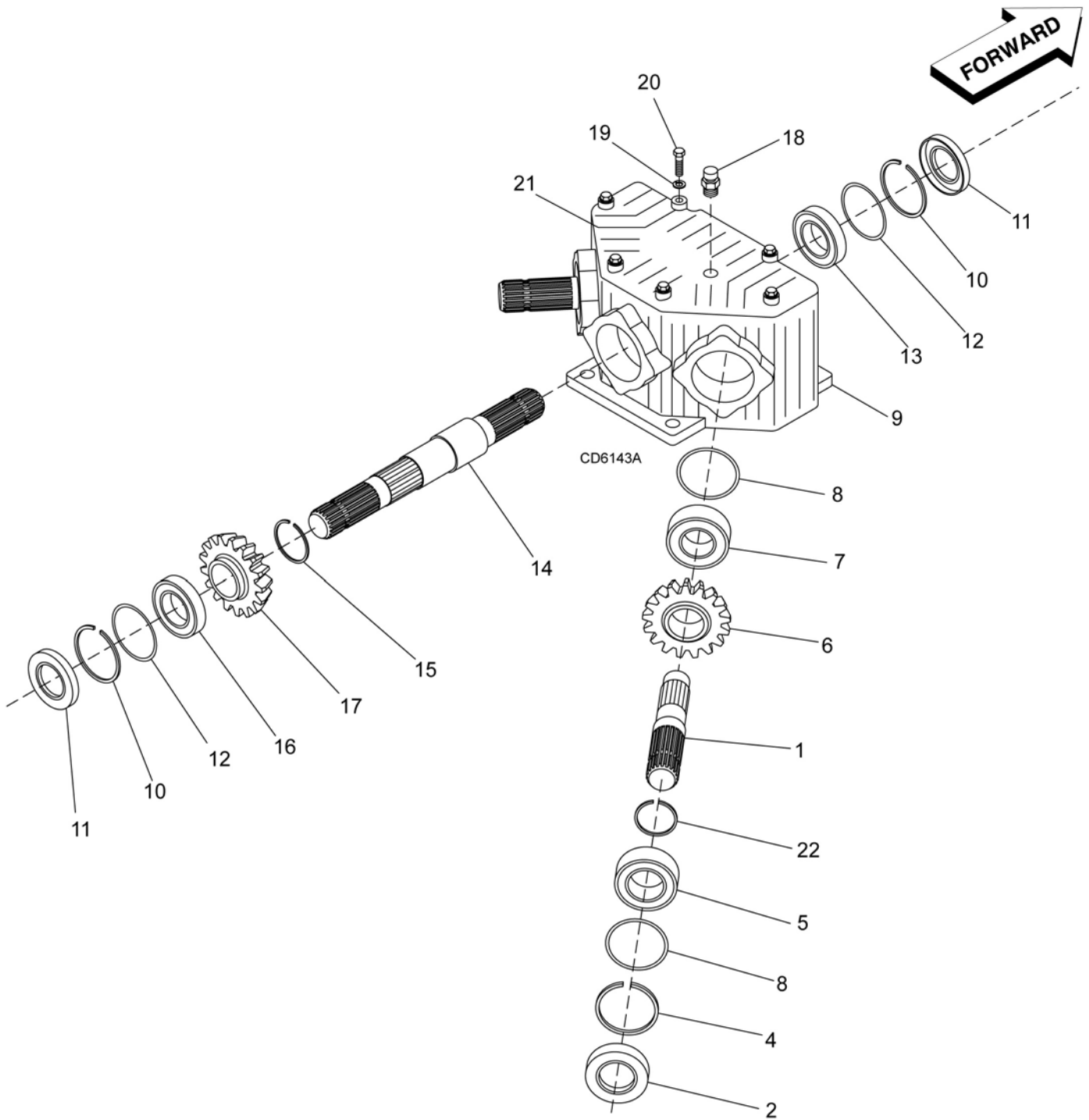

52 Parts

MAN0810 (9/24/2009)

SPLITTER GEARBOX ASSEMBLY

REF	PART	QTY	DESCRIPTION	REF	PART	QTY	DESCRIPTION
A	1003687	1	Complete splitter gearbox	13	1005319	1	Bearing
1	1005308	2	Shaft 1-3/4, 20 spline, wing	14	1005303	1	Shaft 1-3/4, 20 spline, center
2	1005304	2	Oil seal	15	1005309	1	Snap ring
3	-----	2	3/8 Plug (not shown)	16	1005319	1	Bearing
4	39251	2	Snap ring	17	1005310	1	Gear
5	20891	2	Bearing	18	57076	1	1/2 Breather
6	1005305	2	Pinion gear	19	2472 *	6	5/16 Lock washer, standard
7	39414	2	Bearing	20	----- *	6	M8 x 30 HHCS 8.8
8	1005306	4	Shim	21	1005311	1	Cover
9	-----	1	Casting	22	20895	2	Snap ring
10	57320	2	Snap ring				
11	57318	2	Oil seal				
12	1005307	2	Shim				

* Standard hardware, obtain locally

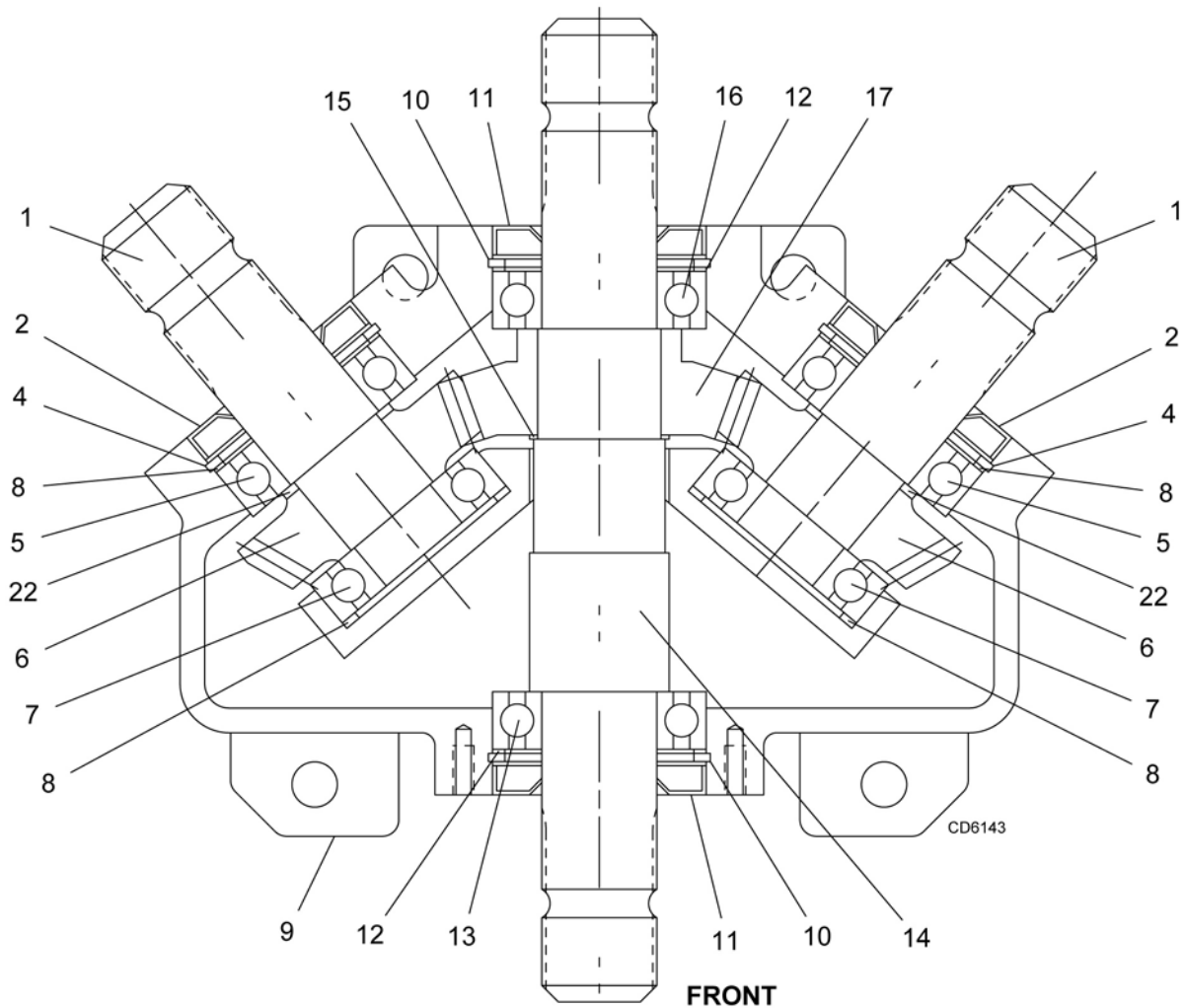

WING & CENTER GEARBOX ASSEMBLY

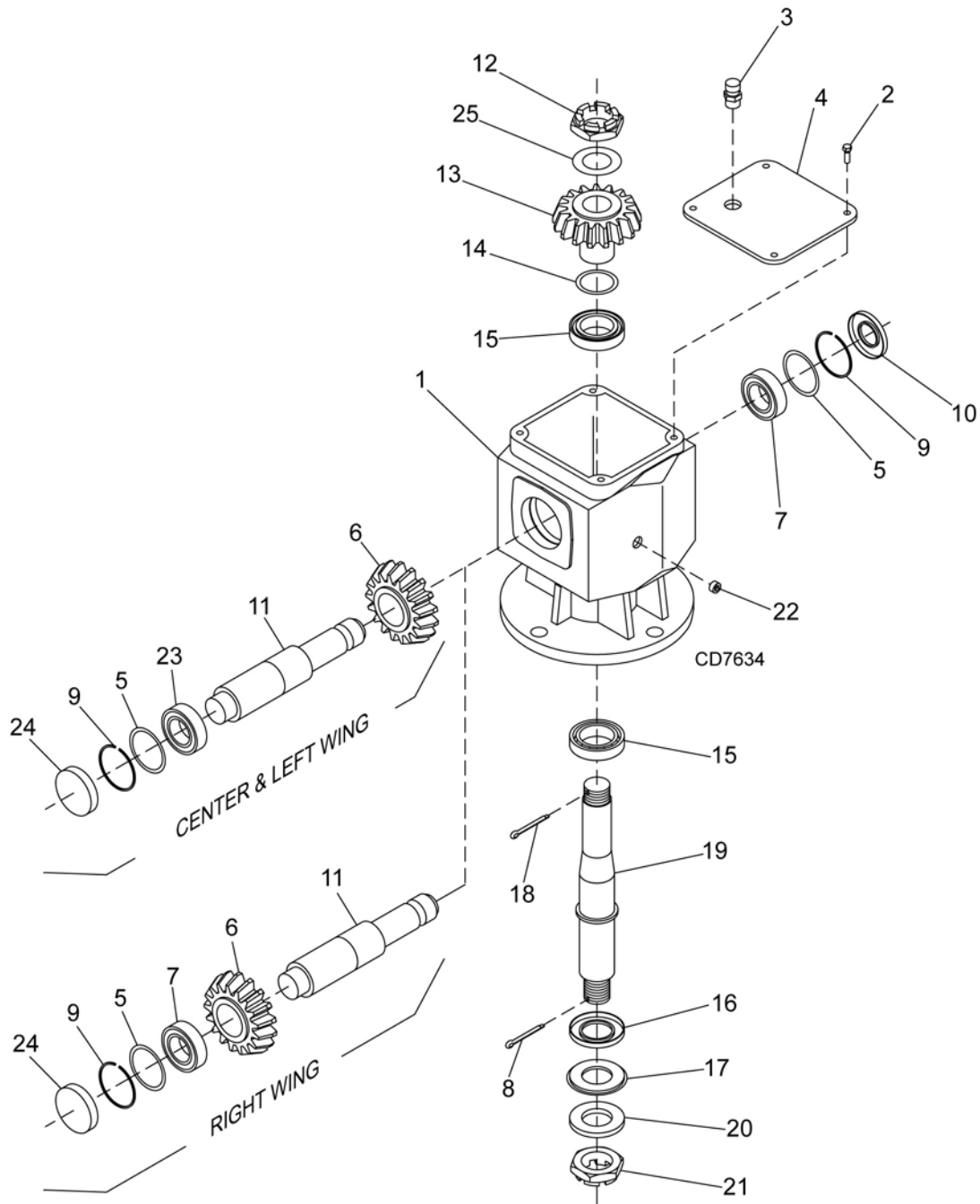

54 Parts

MAN0810 (9/24/2009)

WING & CENTER GEARBOX ASSEMBLY

REF	PART	QTY	DESCRIPTION	REF	PART	QTY	DESCRIPTION
A	1032298	1	Complete gearbox (Center & Left wing) - or -	15	39263	2	Bearing cup & cone
A	1032297	1	Complete gearbox (Right wing)	16	39289	1	Seal 50 x 90 x 10
1	NS	1	Gearbox housing	17	57338	1	Protective washer
2	57150	*	M8 x 1.25 x 14 mm HHCS	18	-----	*	B4 x 55 mm Cotter pin
3	57076	1	1/2 Vent plug	19	57191	1	Output shaft
4	57139	1	Cover	20	39322	1	Flat washer 31 x 56 x 4
5	57328	1	Shim kit 60.3 x 71.7	21	39323	1	M30 x 2.0 Castle nut
6	1009096	1	Crown gear	22	27326	*	3/8 NPT Solid plug
7	57462	1	Bearing cup & cone	23	20890	1	Ball bearing
8	-----	*	B6 x 60 Cotter pin	24	57374	1	Seal 72 x 10
9	57466	2	Snap ring	25	57094	1	Shim 44 x 30.3 x 1
10	57463	1	Seal 35 x 72 x 10		HHCS		Hex Head Cap Screw
11	57147	1	Input shaft 1-3/8 6 spline (Center & Left wing) - or -		NS		Not Serviced
11	1032299	1	Input shaft 1-3/8 6 spline (Right wing)			*	Standard hardware, obtain locally
12	39261	1	M30 x 1.5 Castle nut				
13	1009097	1	Pinion gear				
14	57471	1	Shim kit 50.3 x 70.3				

CENTER DECK DRIVE ASSEMBLY

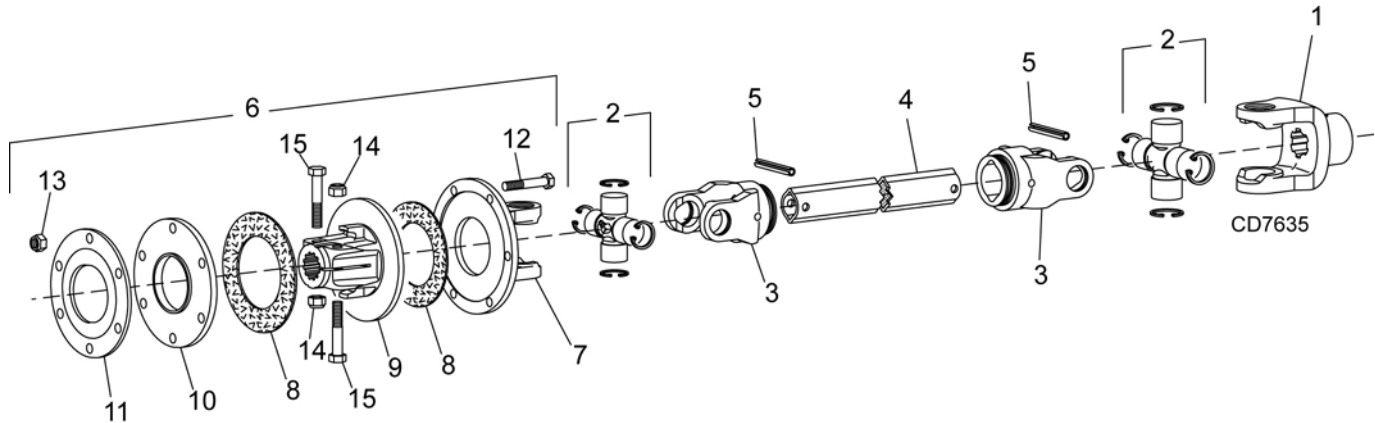

REF	PART	QTY	DESCRIPTION
A	1032185	1	Complete Center Drive Assembly
1	1029929	1	Yoke, 1-3/8, 6 Spline
2	154	2	Cross & Bearing Kit
3	40573	2	Inboard Yoke
4	40592	1	Outer Profile
5	40775	2	Spring Pin, 10 x 65
6	1029928	1	Friction Clutch 1240, 100Nm
7	57431	1	Flange Yoke

REF	PART	QTY	DESCRIPTION
8	57432	1	Friction Disc (package of 2)
9	57440	1	Hub, 1-3/4, 20 Spline
10	57434	1	Thrust Plate
11	57439	1	Belleville Spring Plate
12	57259	6	M10 x 1.5P x 50 HHCS 8.8
13	57260	6	M10 x 1.5P Hex Lock Nut
14	57261	2	M12 x 1.75P Hex Lock Nut
15	57262	2	M12 x 1.75P x 65mm HHCS 8.8
16	1005508		Clutch Repair Kit (Includes items 8, 11-15)

CV DRIVE ASSEMBLY

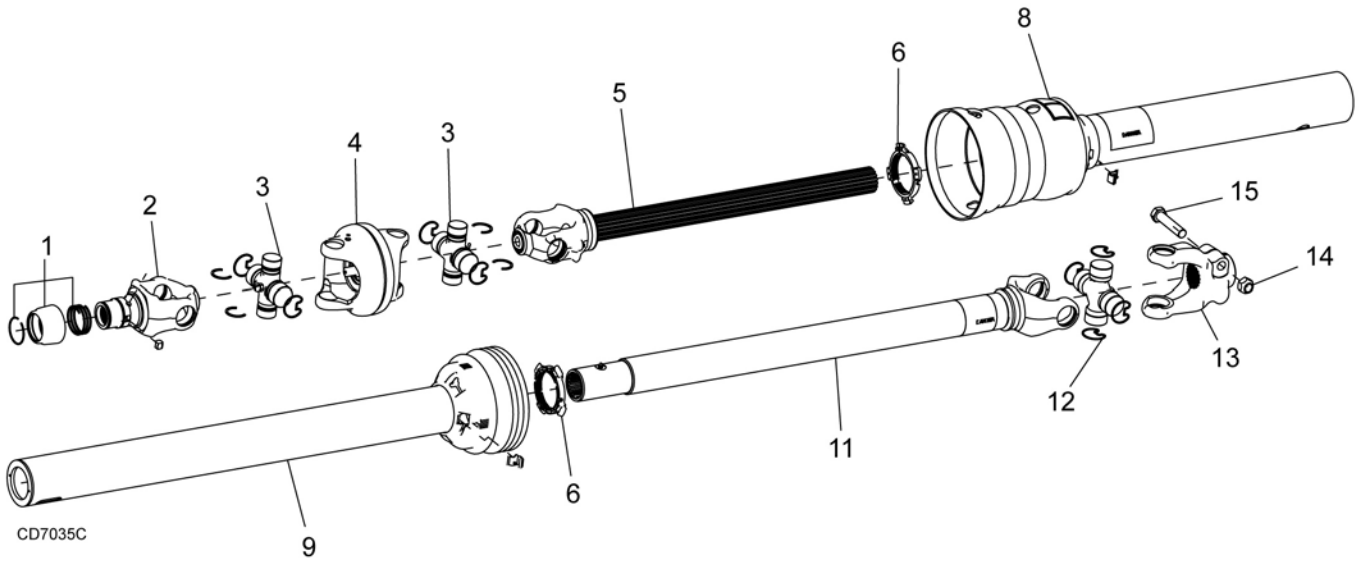

REF	PART	QTY	DESCRIPTION
A	1032189	1	Complete CV drive
1	19851	1	Slide lock repair kit
2	1032289	1	Yoke QD CV 1-3/8 - 6
3	1032290	2	CV U-Joint repair kit Cat 4 35E
4	1032291	1	CV Body with fitting
5	1032292	1	Yoke and shaft CV 1.31-20 spline
6	1024636	2	Drive shield bearing kit
7	18864 †	1	Decal, danger rotating driveline (see page 12)
8	1032293	1	CV shield outer
9	1032294	1	CV shield inner

REF	PART	QTY	DESCRIPTION
10	33347 †	1	Decal, danger guard missing (see page 13)
11	1032295	1	Yoke, tube and slip sleeve
12	1032296	1	U-Joint cross and bearing kit
13	1032269	1	Yoke, 35R x 4.81 x SP 1.75 - 20
14	6239 *	1	5/8 NC Lock nut
15	34473 *	1	5/8 NC x 3 HHCS GR5

† Not shown

HHCS Hex Head Cap Screw

* Standard hardware, obtain locally

WING DRIVE ASSEMBLY (WALTERSCHEID)

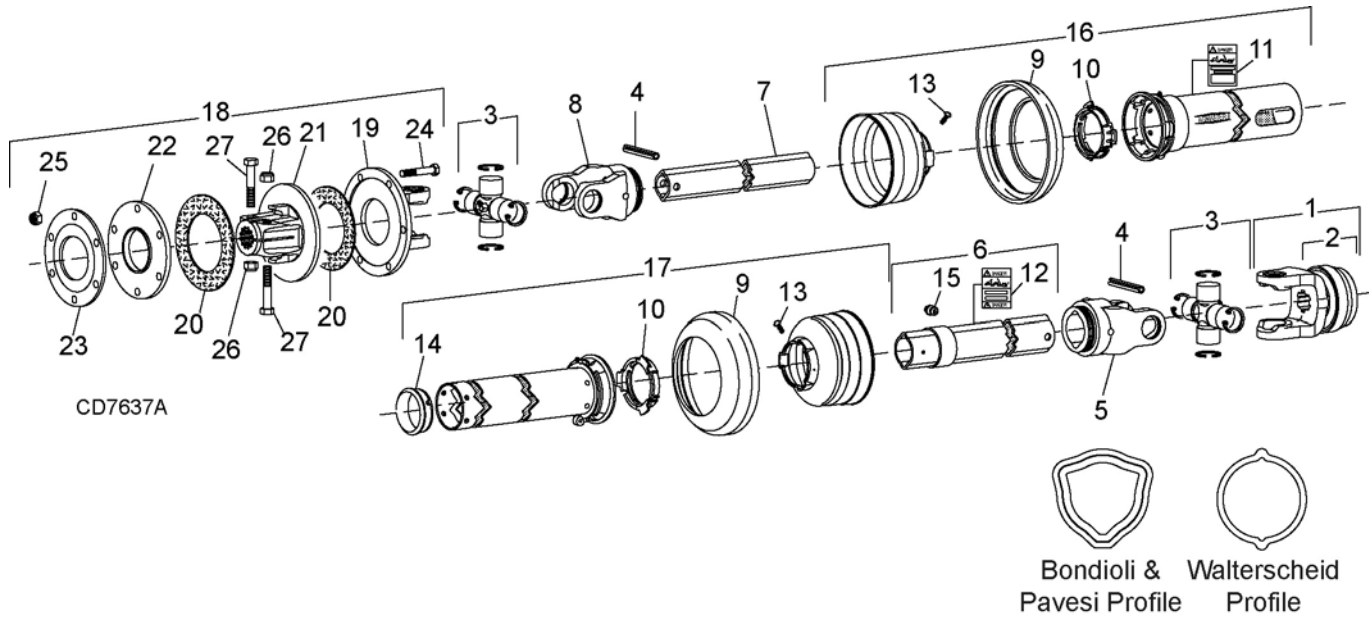

REF	PART	QTY	DESCRIPTION	REF	PART	QTY	DESCRIPTION
A	1032186		Complete Wing Drive Assembly	14	40780	1	Support Bearing
1	40571	1	Yoke, 1-3/8, 6 Spline	15	40779	1	Grease Fitting
2	40589	1	Slide Collar Kit	16	1029933	1	Outer Guard Half
3	154	2	Cross & Bearing Kit	17	1029934	1	Inner Guard Half
4	40775	2	Spring Pin	18	1029930	1	Friction Clutch
5	40573	1	Inboard Yoke	19	57431	1	Flange Yoke
6	1029931	1	Outer Profile & Sleeve	20	57432	1	Friction Disc (pkg of 2)
7	1031172	1	Inner Profile (Must Be Cut to Length)	21	57440	1	Hub, 1-3/4, 20 Spline
8	40572	1	Inner Yoke	22	57434	1	Thrust Plate
9	1029932	2	Reinforcing Collar	23	57435	1	Belleville Spring
10	40776	2	Bearing Ring	24	57259	6	M10 x 1.5P x 55mm HHCS 8.8
11	18864	1	Decal, Danger Rotating Drive	25	57260	6	M10 x 1.5P Hex Lock Nut
12	33347	1	Decal, Danger Guard Missing	26	57261	2	M12 x 1.75P Hex Lock Nut
13	40778	2	Screw (pkg of 10)	27	57262	2	M12 x 1.75P x 65mm HHCS 8.8
				HHCS			Hex Head Cap Screw

WING DRIVE ASSEMBLY (BODIOLI AND PAVESI)

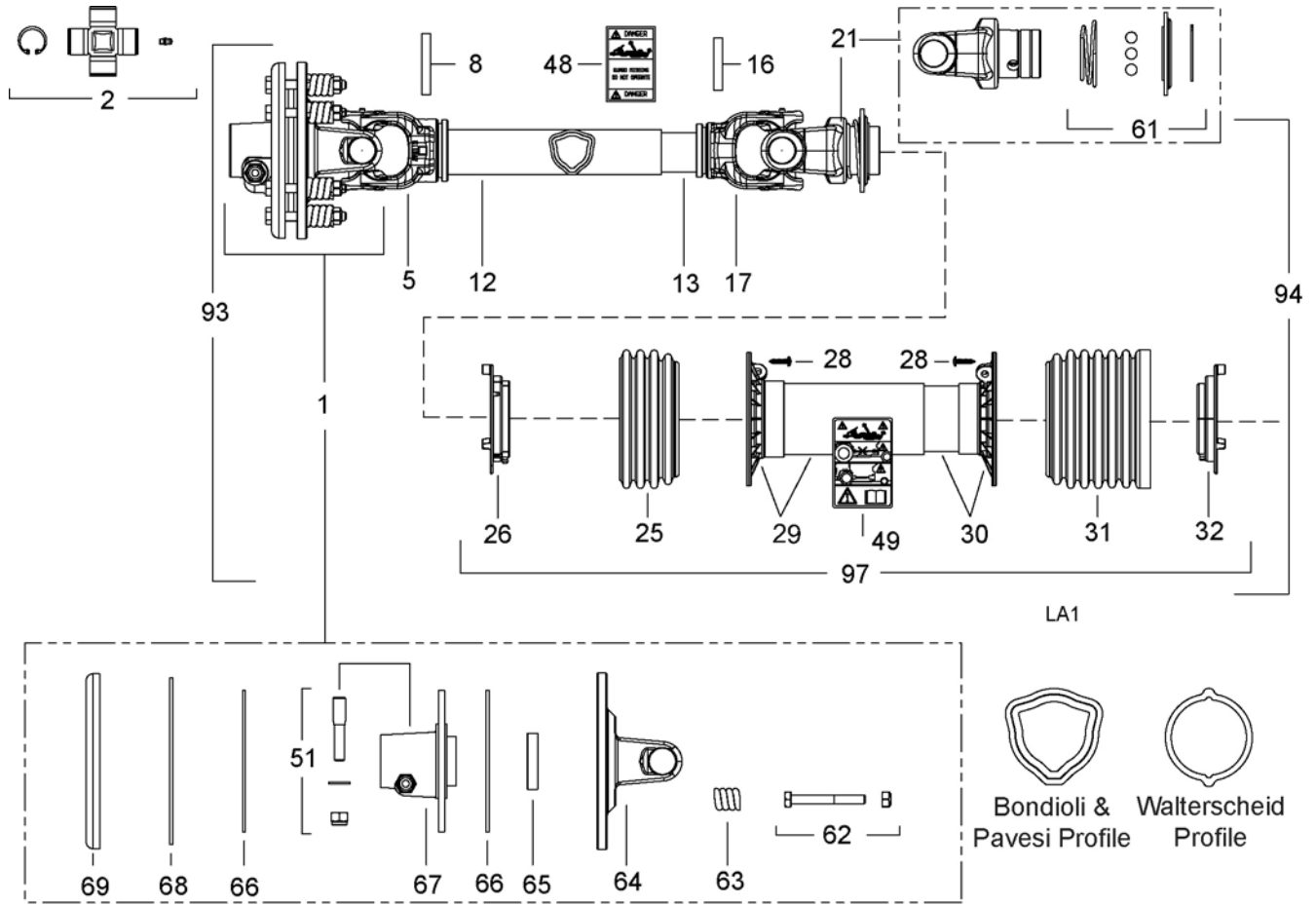

REF	PART	QTY	DESCRIPTION	REF	PART	QTY	DESCRIPTION
1	NSS	--	Clutch Assembly (Order 1032186)	49	18864	1	Decal, DNGR Rotating Driveline
2	1032952	2	U-Joint Repair Kit 50 Series Cap Zerk	51	1032954	1	Pin, Taper B & P
5	NSS	--	Outer Tube and Yoke (Order 1032186)	61	NSS	--	Collar Kit (Order 1032953)
8	*	1	10mm x 70mm Spirol Pin	62	*	8	Bolt-Nut M10 x 85 CL8.8
12	NSS	--	Outer Profile Tube (Order 1032186)	63	1032955	8	Spring, B & P Clutch
13	NSS	--	Inner Profile Tube (Order 1032186)	64	1032956	1	Yoke, Flange B & P Clutch
16	*	1	10mm x 60mm Spirol Pin	65	1032957	1	Bushing, B & P Clutch
17	NSS	--	Inner Tube and Yoke (Order 1032186)	66	1032958	2	Friction Disk, B & P Clutch
21	1032953	1	Yoke 1-3/8-6 Spline 50 Series, QD	67	1032959	1	Hub, 1-3/4 20 B & P Clutch
25	NSS	--	Bell Shield (Included in Item 97)	68	1032960	1	Inner Plate, B & P Clutch
26	NSS	--	Shield Bearing (Included in Item 97)	69	1032961	1	Pressure Plate, B & P Clutch
28	*	6	Screw 4.8 x 22 Self Tapping	93	NSS	--	Clutch-half Assembly (Order 1032186)
29	NSS	--	Outer Shield (Included in Item 97)	94	NSS	--	Tractor-half Assembly (Order 1032186)
30	NSS	--	Inner Shield (Included in Item 97)	97	1032962	1	Shield Kit, Complete B & P
31	NSS	--	Bell Shield (Included in Item 97)		1032186	--	Complete Drive Assembly (Walterscheid)
32	NSS	--	Shield Bearing (Included in Item 97)		NSS		Not Services Separately
48	33347	1	Decal, DNGR Guard Missing		*		Standard Hardware, Obtain Locally

5-BOLT WHEEL & TIRE ASSEMBLY

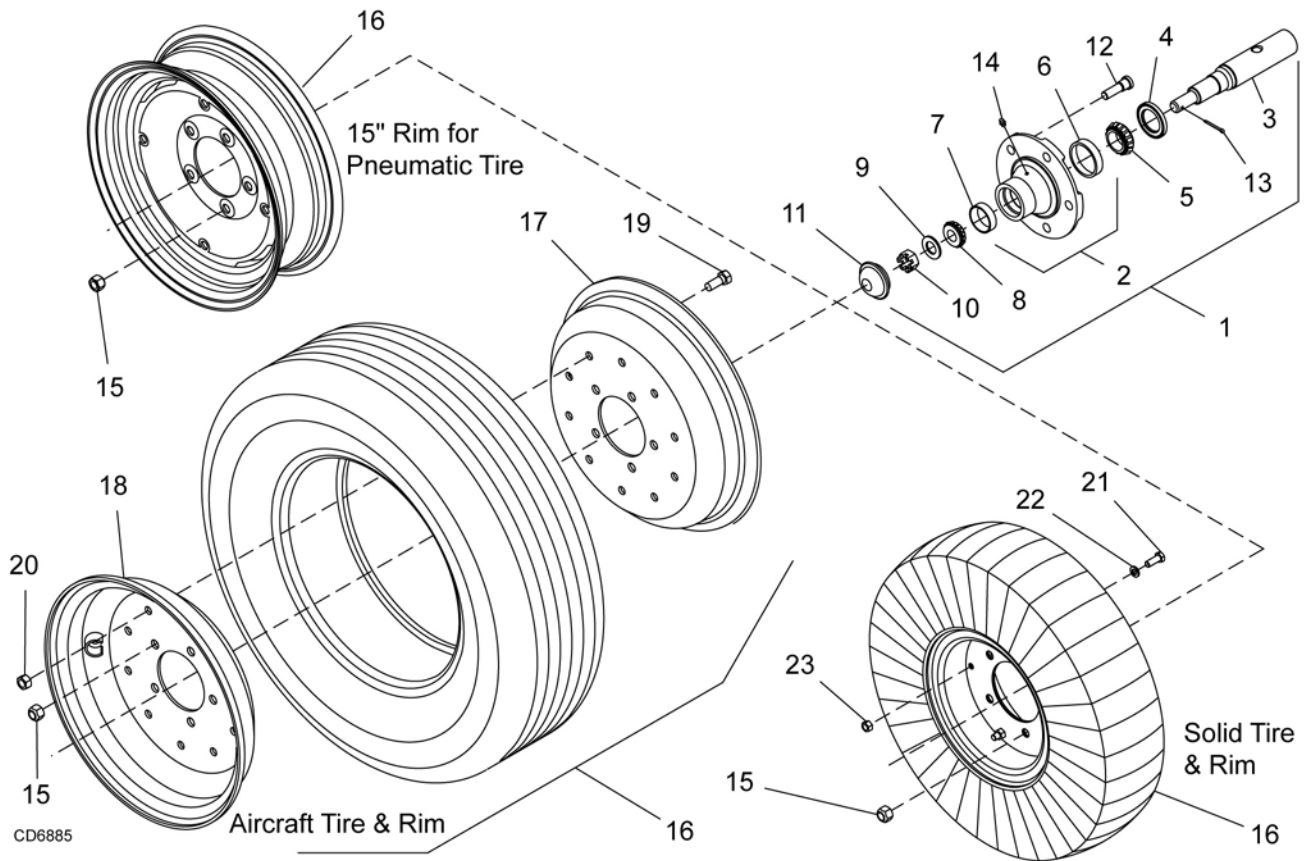

REF	PART	QTY	DESCRIPTION	REF	PART	QTY	DESCRIPTION
1	1017050	1	Heavy hub assembly (includes items 1 through 15)	16	1017040	1	6.00 x 9 Solid tire, rim & hardware - 5 bolt -or-
2	1017034	1	Heavy wheel hub with cups (includes items 6,7,14)	16	1028820	1	24 x 7.25 x 12 Aircraft tire, rim & hardware - 5 bolt -or-
3	1017033	1	Axle	16	1028820F	1	24 x 7.25 x 12 Aircraft tire, rim & hardware, foam filled - 5 bolt
4	1017027	1	Seal	17	1028821	1	12.0 x 6 Rim half (for 24" aircraft wheel only) -or-
5	1017028	1	Bearing cone	18	1028822	1	12.0 x 6 Rim half (for 24" aircraft wheel only)
6	1017036	1	Bearing cup	19	6100 *		1/2 NC x 1-1/4 HHCS GR5
7	1017037	1	Bearing cup	20	765 *		1/2 NC Lock nut
8	1017029	1	Bearing cone	21	19887 *		3/8 NC x 1 HHCS GR8
9	1017031	1	Washer	22	838 *		3/8 Standard lock washer
10	1017032	1	Castle nut	23	835 *		3/8 NC Hex nut
11	1017035	1	Hub cap	-	1017042	2	Rim half for 6 x 9 solid tire
12	1017038	5	Stud				
13	1017069	1	Cotter pin				
14	1017067	1	Grease fitting				
15	35317	5	Nut, lug 1/2 NF				
16	1017088	1	15" Rim for pneumatic tire - 5 bolt -or-				

* Standard hardware, obtain locally

60 Parts

(Rev. 3/3/2010)
MAN0810 (9/24/2009)

RUBBER SHIELDING - CENTER SECTION (STANDARD) (FRONT & REAR)

REF	PART	QTY	DESCRIPTION
1	1032271	1	Front Center Belt Shield Plate
2	1032272	1	Front Right Belt Shield Plate
3	1032273	1	Front Left Belt Shield Plate
7	1032281	2	Bent Link .18 x 13.00
8	1032282	2	Bent Link .18 x 9.50
9	1032283	2	Rubber Shield Front
13	1032287	1	Rubber Shield Rear
14	1032288	2	Rubber Shield Rear
22	6697	*	3/8 NC x 1 Carriage Bolt GR5
23	14350	*	3/8 NC Flanged Lock Nut

* Standard hardware, obtain locally

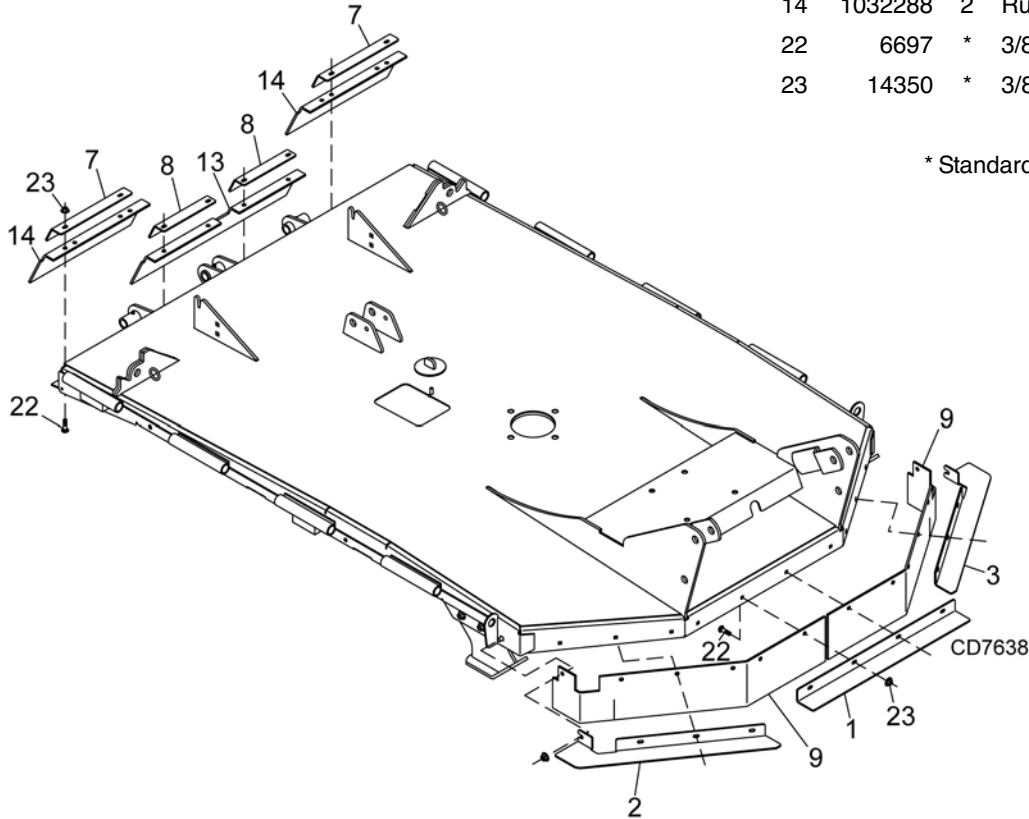

RUBBER SHIELDING - WING (STANDARD) (FRONT & REAR)

REF	PART	QTY	DESCRIPTION
4	1032274	1	Front Right Wind Belt Shield Plate, Inner - or-
4	1032275	1	Front Left Wing Belt Shield Plate, Inner
5	1032276	1	Front Right Wing Belt Shield Plate, Middle - or-
5	1032277	1	Front Left Wing Belt Shield Plate, Middle
6	1032278	1	Front Right Wing Belt Shield Plate, Outer - or-
6	1032279	1	Front Left Wing Belt Shield Plate, Outer
7	1032281	4	Bent Link
10	1032284	2	Rubber Shield Front Side
11	1032285	2	Rubber Shield Front
12	1032286	2	Rubber Shield Rear
20	14406	*	1/2 NC x 1 Carriage Bolt GR5
21	11900	*	1/2 NC Flanged Lock Nut
22	6697	*	3/8 NC x 1 Carriage Bolt GR5
23	14350	*	3/8 NC Flanged Lock Nut

* Standard hardware, obtain locally

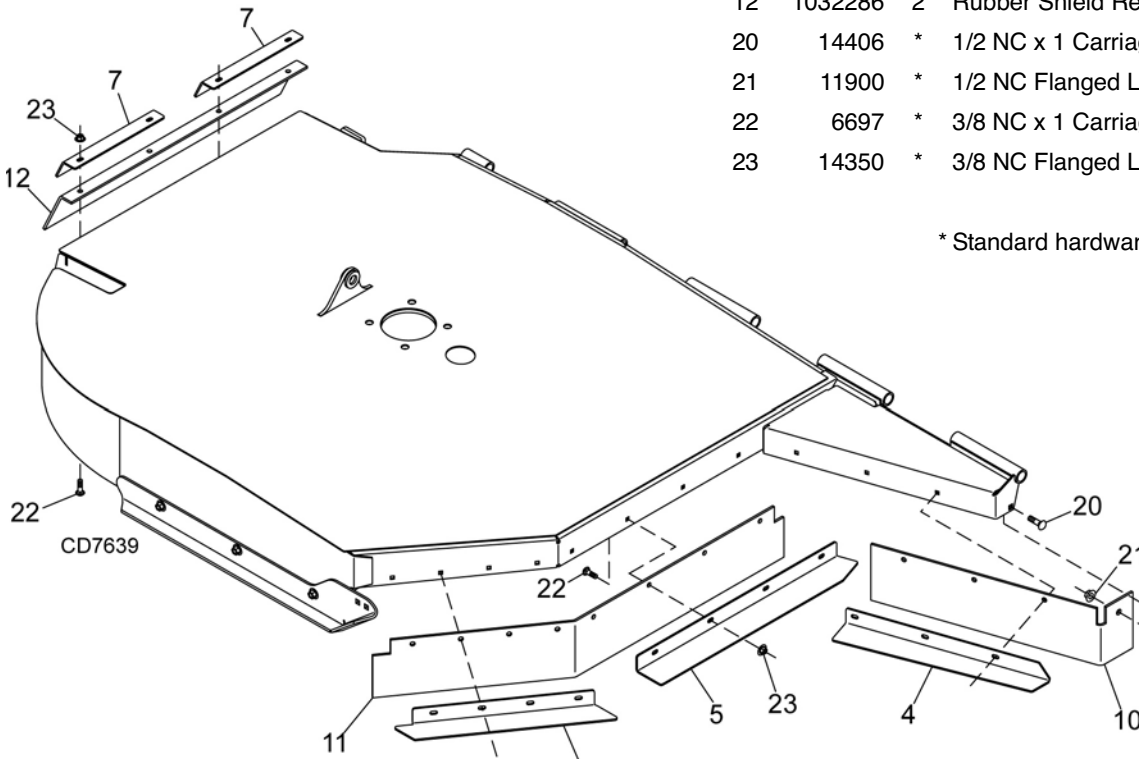

62 Parts

(Rev. 7/9/2010)

MAN0810 (9/24/2009)

**CHAIN SHIELDING - CENTER SECTION (OPTIONAL)
(FRONT & REAR)**

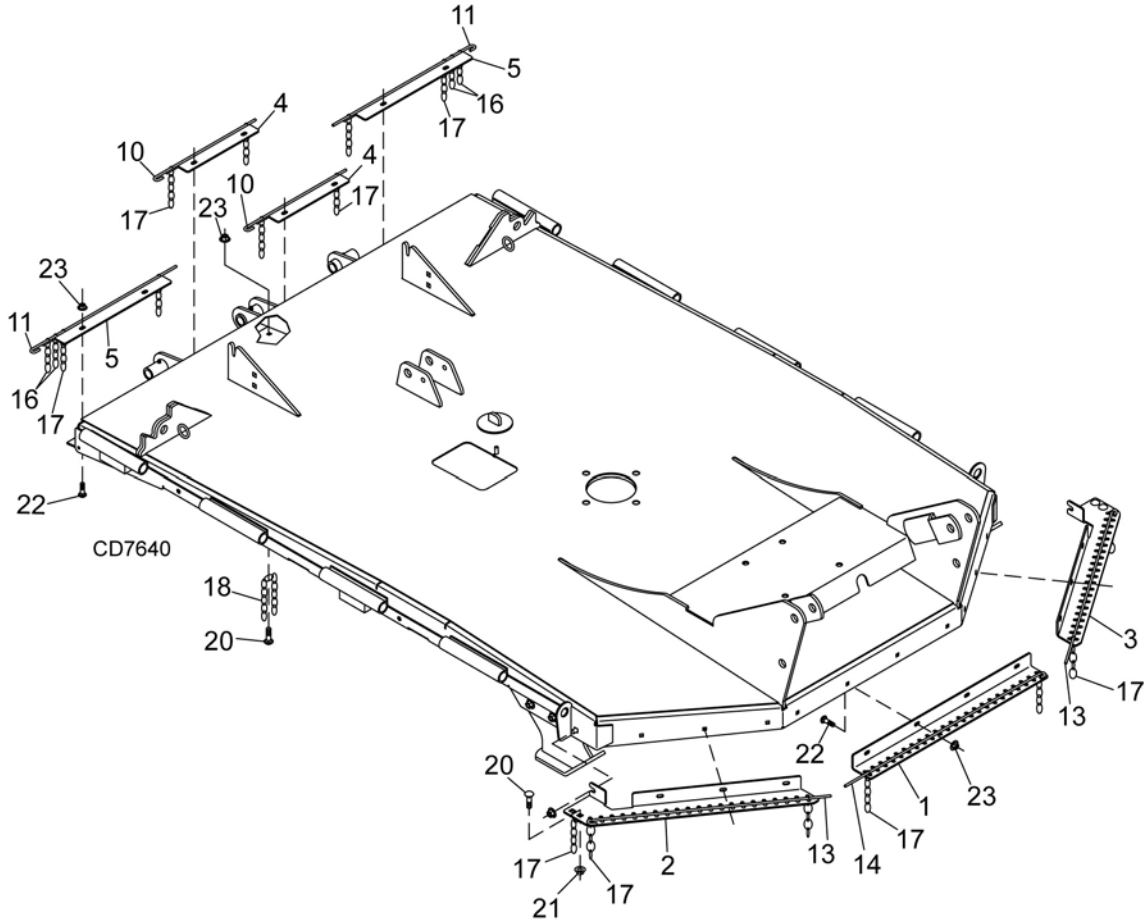

REF	PART	QTY	DESCRIPTION
1	1032241	1	Front Center Chain Plate
2	1032242	1	Front Right Chain Plate
3	1032243	1	Front Left Chain Plate
4	1032251	2	Rear Chain Plate, Inner
5	1032252	2	Rear Chain Plate, Outer
10	1007852	2	Pin, 9 to 11 Chains
11	1003639	2	Pin, 13 to 15 Chains
13	1003643	2	Pin, 19 to 21 Chains
14	1003644	1	Pin, 22 to 24 Chains
16	4069	4	5/16 Chain - 4 Link
17	3994	113	5/16 Chain - 5 Link
18	1016953	1	5/16 Chain - 11 Link
20	3231	*	3/8 NC x 2 HHCS GR5
22	6697	*	3/8 NC x 1 Carriage Bolt GR5
23	14350	*	3/8 NC Flanged Lock Nut

* Standard hardware, obtain locally

HHCS Hex Head Cap Screw

**CHAIN SHIELDING - WING (OPTIONAL)
(FRONT & REAR)**

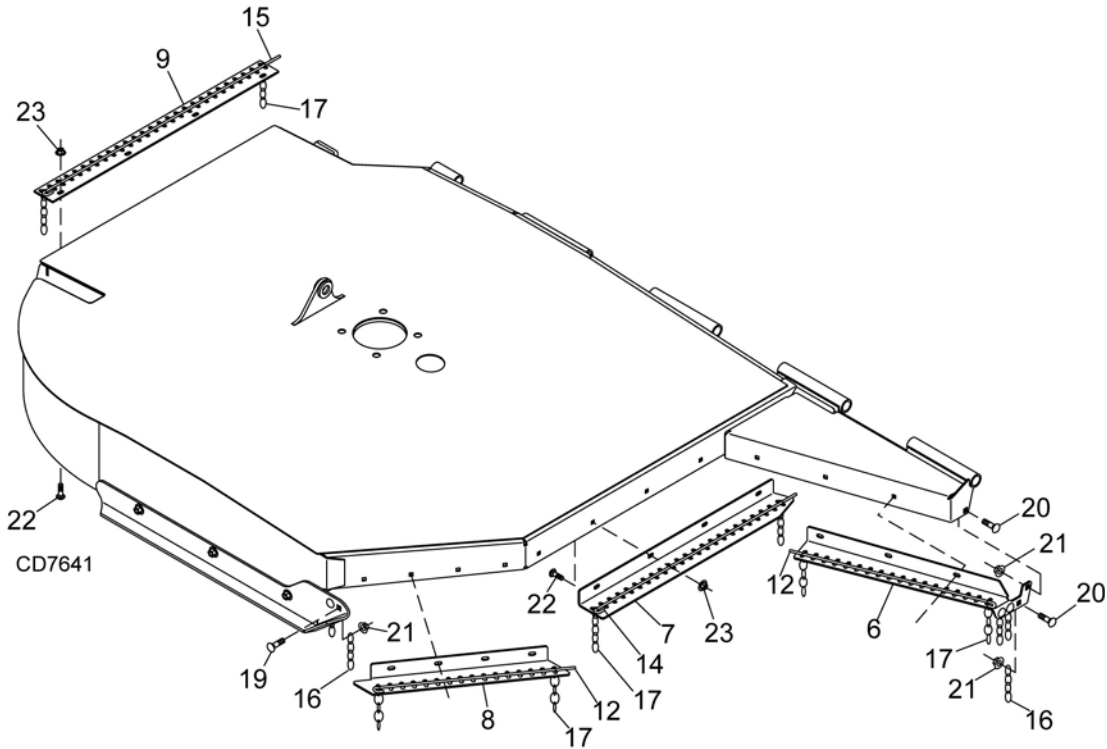

REF	PART	QTY	DESCRIPTION
6	1032244	1	Front Right Wing Chain Plate, Inner - Or-
6	1032245	1	Front Left Wing Chain Plate, Inner
7	1032246	1	Front Right Wing Chain plate, Middle - Or-
7	1032247	1	Front Left Wing Chain Plate, Middle
8	1032248	1	Front Right Wing Chain Plate, Outer - or-
8	1032249	1	Front Left Wing Chain Plate, Outer
9	1028174	2	Rear Wing Chain Plate
12	1003642	4	Pin, 16 To 18 Chains
14	1003644	2	Pin, 22 To 24 Chains
15	1003645	2	Pin, 25 To 27 Chains
16	4069	10	5/16 Chain - 4 Link
17	3994	168	5/16 Chain - 5 Link
19	29893	*	1/2 NC X 1-1/2 Carriage Bolt GR5
20	14406	*	1/2 NC X 1 Carriage Bolt GR5
21	11900	*	1/2 NC Flanged Lock Nut
22	6697	*	3/8 NC X 1 Carriage Bolt GR5
23	14350	*	3/8 NC Flanged Lock Nut

*Standard hardware, obtain locally

HYDRAULIC CYLINDERS

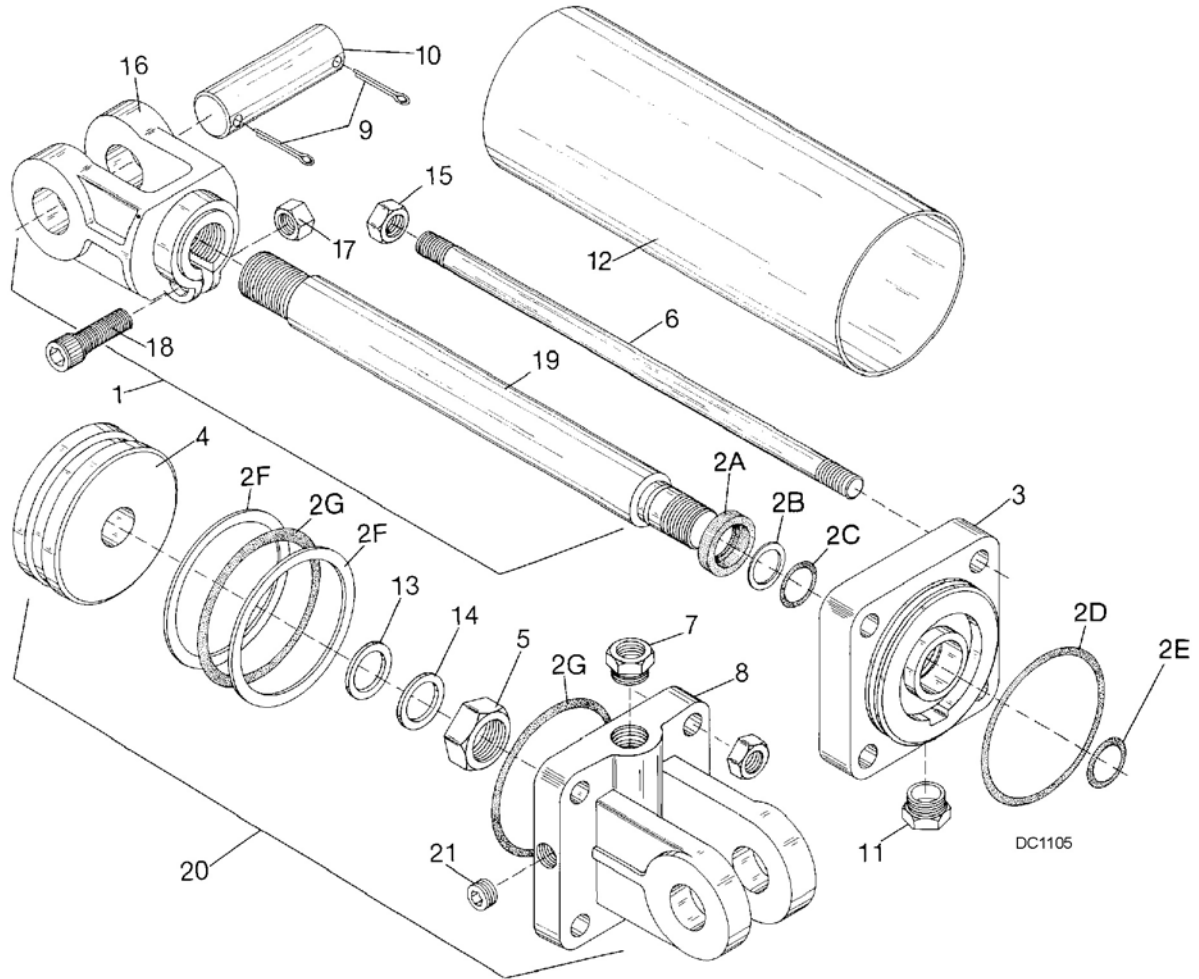

		Wing 3 x 10	Center 3 x 8					Wing 3 x 10	Center 3 x 8		
REF	PART	PART	QTY	DESCRIPTION	REF	PART	PART	QTY	DESCRIPTION		
2	19810	19810	4	Seal repair kit (includes 2A thru 2G)	10	1631	1631	2	1 x 3-5/8 Clevis pin		
	- or -	- or -			11	11893*	-----	1	1/2 x 1/4 Pipe reducer bushing -or-		
2	19810HD	19810HD	4	Seal kit w/ heavy duty piston seal	11	11975	11975	1	1/2 NPT Vent plug		
2A	‡	‡	1	Wiper seal	12	NS	NS	1	Cylinder barrel		
2C	‡	‡	2	1-1/4 ID U-Cup	15	*	*	8	Tie rod nut		
2D	‡	‡	2	Barrel O-ring	16	23549	23549	1	Hydraulic cylinder rod clevis		
2E	†	†		Rod static O-ring	17	6698*	6698*	1	3/8 NC Lock nut		
2F	‡	‡	2	Piston back-up washer	18	23550*	23550*	1	3/8 NC x 1-1/2 Socket head cap screw		
2G	‡	‡	1	Piston seal O-ring	19	NS	NS	1	Hydraulic cylinder rod		
3	NS	NS	1	Rod end housing	20	1031166	-----	1	3 x 10 Hydraulic cylinder - Wing		
4	NS	NS	1	Piston	20	-----	29547	1	3 x 8 Hydraulic cylinder w/ breather complete - Center		
5	34328	34328	1	Jam nut						*	Obtain Locally
6	NS	NS	4	Cylinder tie rod						†	Not used on this cylinder
7	4510	4510	1	1/2 Pipe plug -or-						‡	Included in seal kit
7	11893*	11893*	1	1/2 x 1/4 Pipe reducer bushing						NS	Not sold separately
8	NS	NS	1	Cylinder butt end							
9	923*	923*	4	1/4 x 1-3/4 Cotter pin							

HYDRAULIC CYLINDER STROKE CONTROL KIT

REF	PART	QTY	DESCRIPTION
1	24098	1	Stroke control set for 1-1/4" cylinder rod (contains items 2 - 5)
2	----	2	1-1/2" Segment
3	----	1	1-1/4" Segment
4	----	1	1" Segment
5	----	1	3/4" Segment

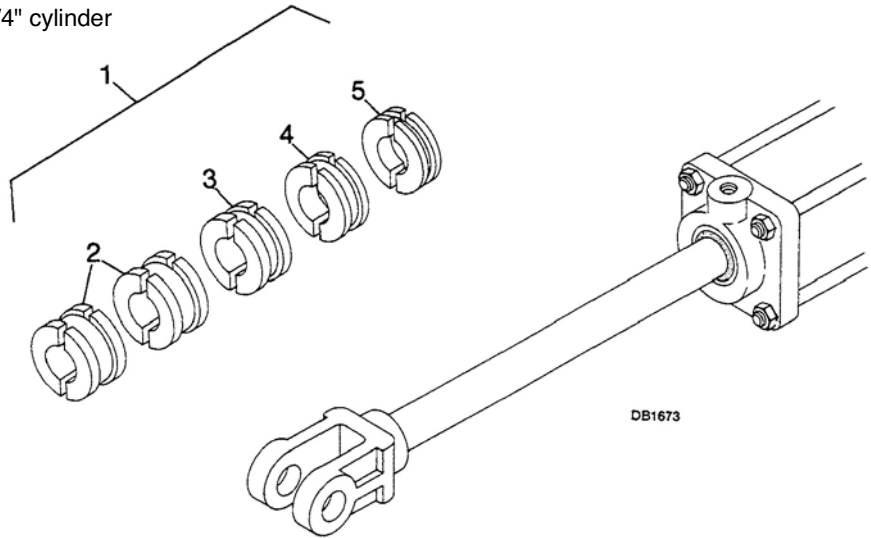

CROSSBAR PULLER (OPTIONAL)

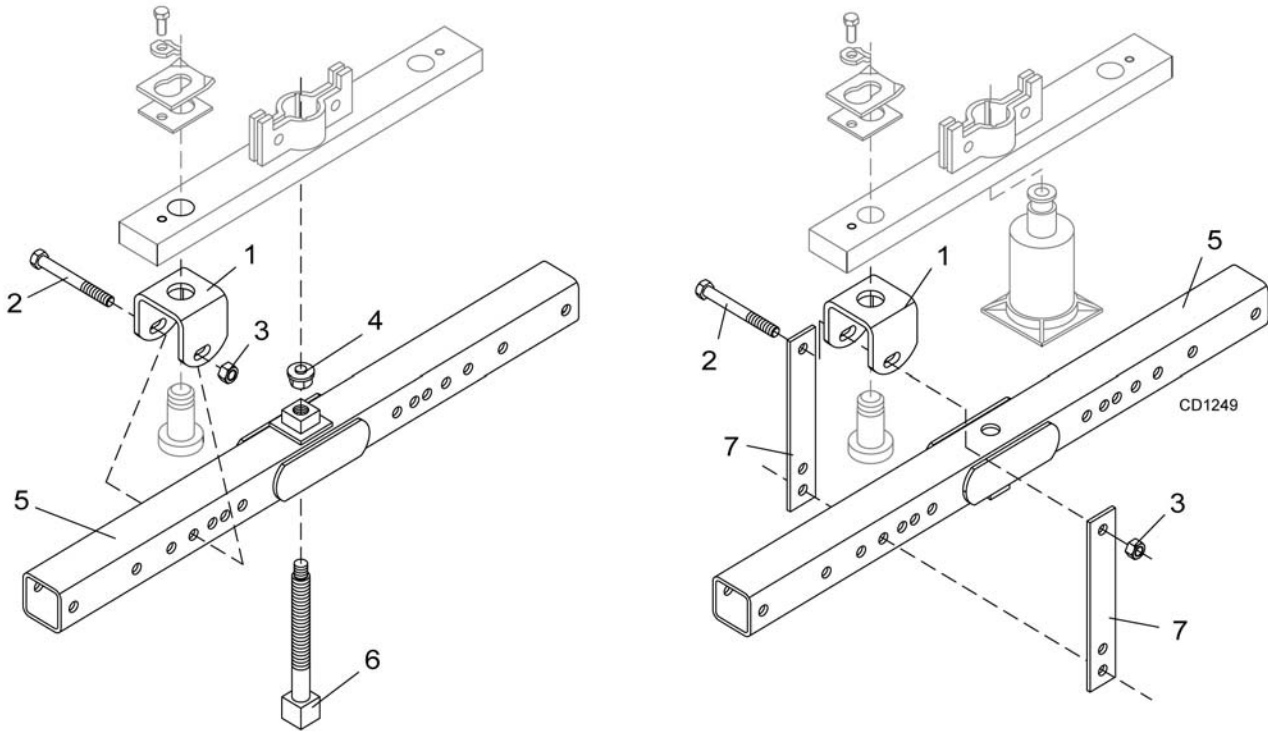

REF	PART	QTY	DESCRIPTION
A	8811	1	Crossbar puller, complete
1	19914	2	Crossbar puller clevis
2	3097 *	4	5/8 NC x 4-1/2 HHCS GR5
3	230 *	4	5/8 NC Hex nut

REF	PART	QTY	DESCRIPTION
4	24879	1	Crossbar puller pad assembly
5	24876	1	Crossbar puller tube assembly
6	24881	1	Crossbar puller screw assembly
7	24885	4	Crossbar puller link

* Standard hardware - obtain locally

66 Parts

MAN0810 (9/24/2009)

WINCH KIT (OPTIONAL)

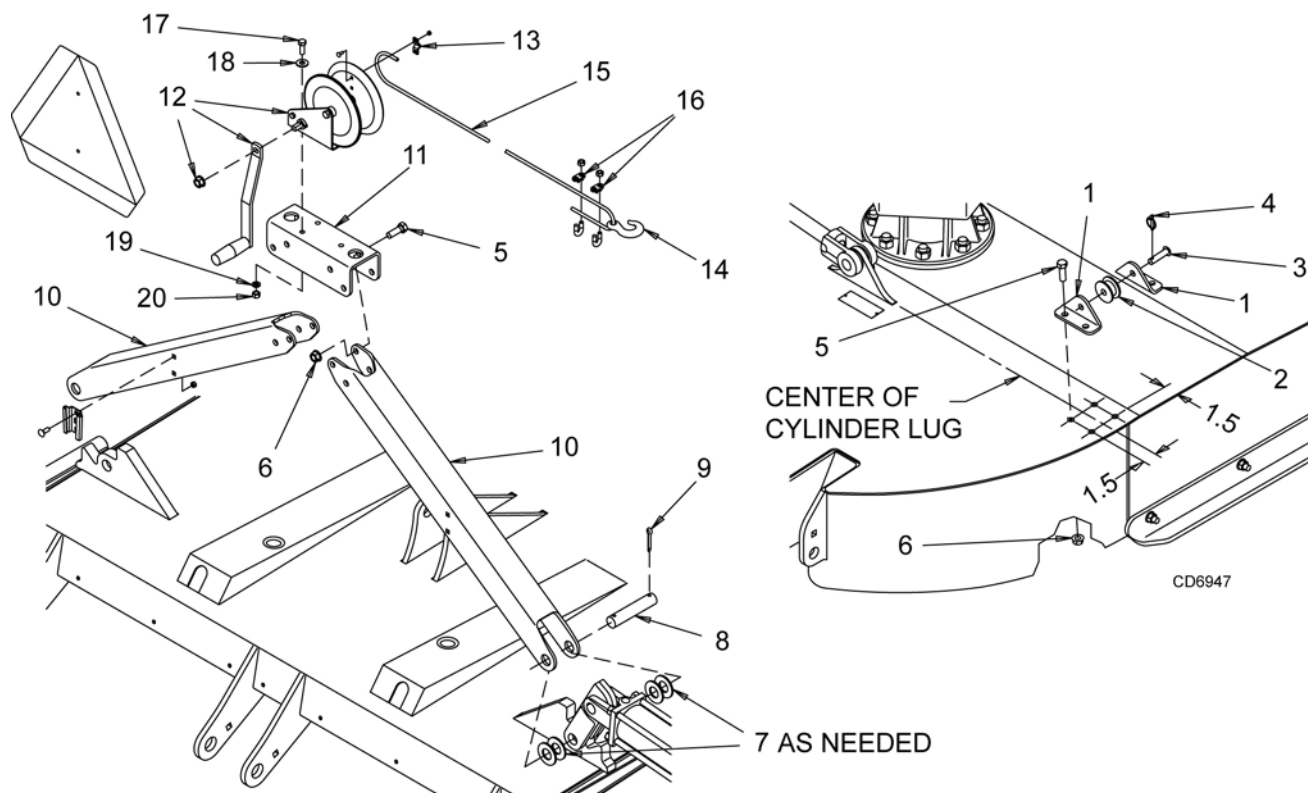

REF	PART	QTY	DESCRIPTION
A	1019456	-	Winch kit, complete
1	52478	4	Idler bracket
2	6696	2	Chain idler casting
3	409	2	Clevis pin, 1/2 x 2
4	22411	2	Klik pin, 3/16 x 1
5	3379 *	-	HHCS, 1/2 NC x 1-1/2 GR5
6	11900 *	-	Lock nut, 1/2 NC flanged
7	1863 *	-	Washer, 1" SAE flat
8	1008325	2	Headless pin, 1 x 4 drilled
9	1266 *	-	Cotter pin, 3/16 x 1-1/2
10	1019454	2	Channel, 2.56 x 2.75 x 32.88
11	1019455	1	Channel, 3.12 x 3.25 x 10.00
12	12612	1	Gear winch 5.1 to 1
13	12642	1	Winch cable clamp kit
14	11790	1	C-Hook, 1/4 cable
15	52479	1	Cable, 1/4" x 24-ft
16	11789	2	Clip, 1/4 cable
17	839 *	-	HHCS, NC x 1 GR5
18	565 *	-	Washer, 3/8 flat
19	838 *	-	Washer, 3/8 lock
20	835 *	-	Hex nut, 3/8 NC plated

* Standard hardware; obtain locally

Winch Kit Installation

1. Locate and drill one 9/16" hole in each wing as shown. Assemble items 1, 2, 3 and 4 and use to locate and drill remaining holes.
2. Secure idler brackets (1) and rollers (2) to deck with bolts (5) and nuts (6).
3. Assemble channels (10) to cylinder lugs using pins (8), washers (7), and cotter pins (9) as shown.
4. Assemble winch assembly to channels (10) using bolts (5) and lock nuts (6).
5. Move SMV sign and hardware to channel as shown.
6. Tighten all hardware.

Winch Kit Operation

1. Move cutter so wing is on the up slope of a ditch to aid in wing lift with the winch.
2. Unwind cable and remove roller (2).
3. Place cable around roller (2) and reinstall using pin (3) and Klik pin (4).
4. Remove cylinder pin from clevis end and raise slowly.
5. Install transport lock before moving unit.

BOLT TORQUE CHART

Always tighten hardware to these values unless a different torque value or tightening procedure is listed for a specific application.

Fasteners must always be replaced with the same grade as specified in the manual parts list.

Always use the proper tool for tightening hardware: SAE for SAE hardware and Metric for metric hardware.

Make sure fastener threads are clean and you start thread engagement properly.

All torque values are given to specifications used on hardware defined by SAE J1701 MAR 99 & J1701M JUL 96.

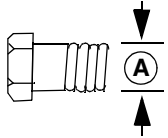

SAE SERIES TORQUE CHART

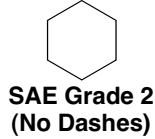

SAE Bolt Head Identification



Ⓐ Diameter (Inches)	Wrench Size	MARKING ON HEAD					
		SAE 2		SAE 5		SAE 8	
		lbs-ft	N-m	lbs-ft	N-m	lbs-ft	N-m
1/4"	7/16"	6	8	10	13	14	18
5/16"	1/2"	12	17	19	26	27	37
3/8"	9/16"	23	31	35	47	49	67
7/16"	5/8"	36	48	55	75	78	106
1/2"	3/4"	55	75	85	115	120	163
9/16"	13/16"	78	106	121	164	171	232
5/8"	15/16"	110	149	170	230	240	325
3/4"	1-1/8"	192	261	297	403	420	569
7/8"	1-5/16"	306	416	474	642	669	907
1"	1-1/2"	467	634	722	979	1020	1383

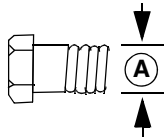

METRIC SERIES TORQUE CHART

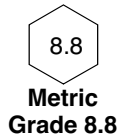

Metric Bolt Head Identification

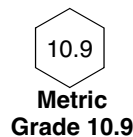

Ⓐ Diameter & Thread Pitch (Millimeters)	Wrench Size	COARSE THREAD				FINE THREAD				Ⓐ Diameter & Thread Pitch (Millimeters)
		MARKING ON HEAD								
		Metric 8.8		Metric 10.9		Metric 8.8		Metric 10.9		
		N-m	lbs-ft	N-m	lbs-ft	N-m	lbs-ft	N-m	lbs-ft	
6 x 1.0	10 mm	8	6	11	8	8	6	11	8	6 x 1.0
8 x 1.25	13 mm	20	15	27	20	21	16	29	22	8 x 1.0
10 x 1.5	16 mm	39	29	54	40	41	30	57	42	10 x 1.25
12 x 1.75	18 mm	68	50	94	70	75	55	103	76	12 x 1.25
14 x 2.0	21 mm	109	80	151	111	118	87	163	120	14 x 1.5
16 x 2.0	24 mm	169	125	234	173	181	133	250	184	16 x 1.5
18 x 2.5	27 mm	234	172	323	239	263	194	363	268	18 x 1.5
20 x 2.5	30 mm	330	244	457	337	367	270	507	374	20 x 1.5
22 x 2.5	34 mm	451	332	623	460	495	365	684	505	22 x 1.5
24 x 3.0	36 mm	571	421	790	583	623	459	861	635	24 x 2.0
30 x 3.0	46 mm	1175	867	1626	1199	1258	928	1740	1283	30 x 2.0

Typical Washer Installations

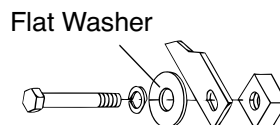
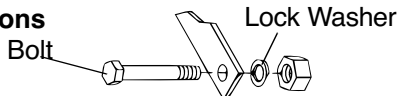

8/9/00

BOLT SIZE CHART

NOTE: Chart shows bolt thread sizes and corresponding head (wrench) sizes for standard SAE and metric bolts.

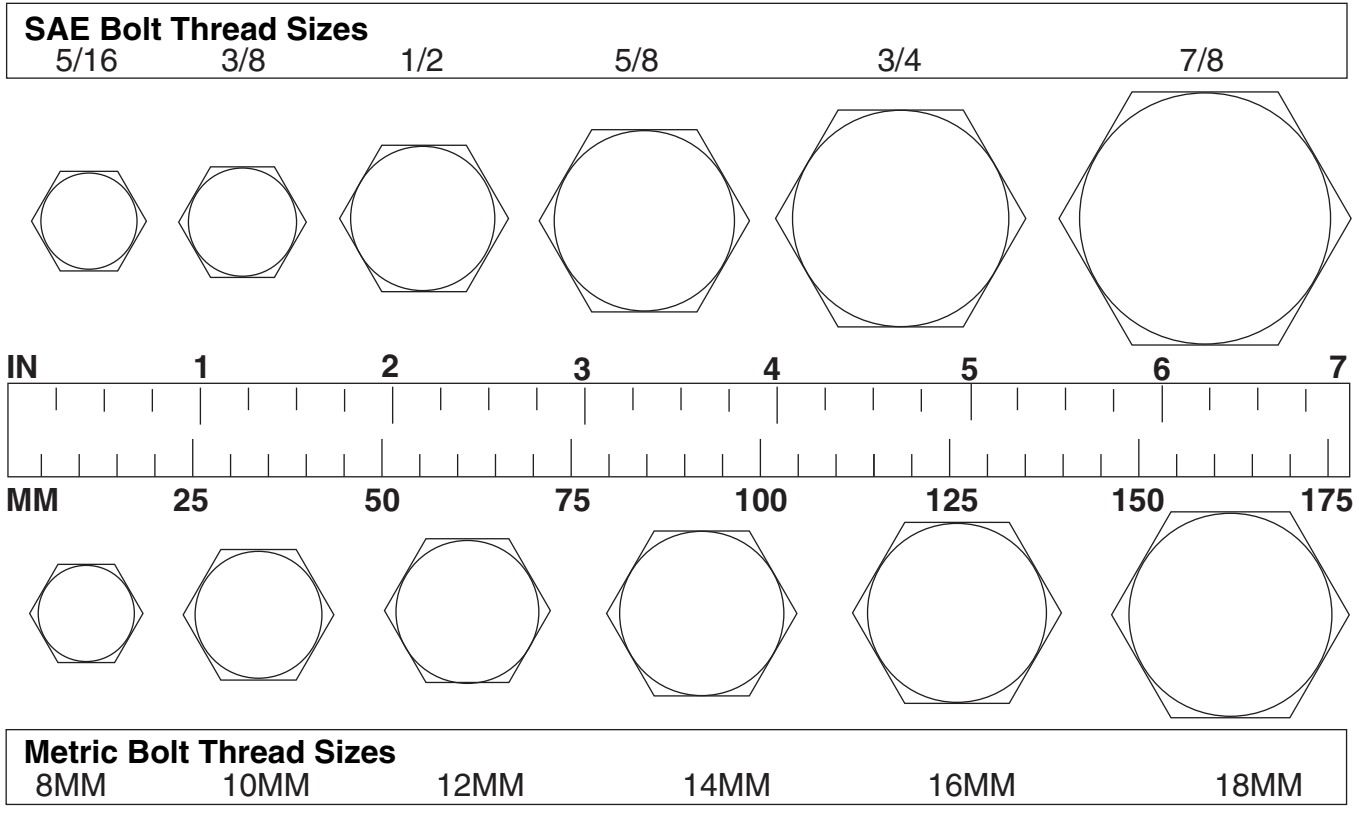

ABBREVIATIONS

AG	Agriculture	MPa.....	Mega Pascal
ASABE.....	American Society of Agricultural & Biological Engineers (formerly ASAE)	N.....	Newton
ASAE	American Society of Agricultural Engineers	NC	National Coarse
ATF	Automatic Transmission Fluid	NF	National Fine
BSPP	British Standard Pipe Parallel	NPSM.....	National Pipe Straight Mechanical
BSPTM	British Standard Pipe Tapered Male	NPT	National Pipe Tapered
CV.....	Constant Velocity	NPT SWF	National Pipe Tapered Swivel Female
CCW	Counter-Clockwise	ORB.....	O-Ring Boss - Male
CW.....	Clockwise	P.....	Pitch
F	Female	PBY	Power-Beyond
FT	Full Thread	psi.....	Pounds per Square Inch
GA	Gauge	PTO.....	Power Take Off
GR (5, etc.)	Grade (5, etc.)	QD.....	Quick Disconnect
HHCS	Hex Head Cap Screw	RH.....	Right Hand
HT.....	Heat-Treated	ROPS	Roll-Over Protective Structure
JIC	Joint Industry Council 37° Degree Flare	RPM	Revolutions Per Minute
LH.....	Left Hand	RT	Right
LT.....	Left	SAE	Society of Automotive Engineers
m.....	Meter	UNC	Unified Coarse
mm.....	Millimeter	UNF	Unified Fine
M.....	Male	UNS.....	Unified Special

INDEX

ADJUSTMENTS

Cutting Height 15

ASSEMBLY

Dealer Set-Up Instructions 34

Fill Gearboxes 34

DEALER CHECK LIST

Check Lists

Delivery (Dealer's Responsibility) 43

Pre-Delivery (Dealer's Responsibility) 43

DEALER SERVICE

Crossbar

Installation 32

Removal 31

Gearbox Maintenance

Horizontal Shaft Seal Repair 26

Seal Installation 25

Seal Replacement 25

Vertical Shaft Seal Repair (Spindle Gearbox) 26

Spindle Gearbox Repair 26

Assemble Gearbox 28

Disassemble Gearbox 26

Reinstall Gearbox 28

Remove Gearbox 26

Splitter Gearbox Repair

Assembly 29

Check Gearbox for Leaks 30

Disassembly 29

Reinstallation 30

Removal from Cutter 29

Universal Joint

Assembly 33

Disassembly 32

Repair 32

GENERAL

Abbreviations 69

Bolt Size Chart 69

Bolt Torque Chart 68

General Information 4

Introduction 2

Obtaining Replacement Manuals 2

Product Registration 2

Specifications 4

Table of Contents 3

Warranty

Product 71

Replacement Parts Back Cover

OPERATION

Connecting Cutter to Tractor 14

Cutting Height Adjustment 15

CV Driveline Turning Limits 15

Hydraulic Connection 14

Interference Check 15

Cutter Operation 16

Mowing Tips 16

Shredding 16

Pre-Operation Check List (Owner's Responsibility)
18

Storage 18

Tractor Operation 15

Transporting 17

Lock-Up 17

Center Section 17

Wing 17

OWNER SERVICE

Blades

Installation 21

Removal 21

Sharpening 22

Blocking Method 19

Lubrication

Driveline 20

Gearbox 20

Lubrication Points 20

Seasonal 21

Shielding Repair 23

Slip Clutch Adjustment 22

PARTS

Parts Index 45

SAFETY

Blocking Method 19

Check Lists

Delivery Check List (Dealer's Responsibility) 43

Pre-Delivery Check List (Dealer's Responsibility) 43

Pre-Operation Check List (Owner's Responsibility)
18

Free Mower Safety Video Order Form 5, 6

Safety & Instructional Decals 11, 12, 13

Safety Rules 7, 8, 9, 10

Safety Symbols Explained 2

TROUBLESHOOTING 24



WARRANTY

All Models Except Mow'n Machine™ Zero-Turn Mowers

Please Enter Information Below and Save for Future Reference.

Date Purchased: _____ From (Dealer): _____

Model Number: _____ Serial Number: _____

Woods Equipment Company ("WOODS") warrants this product to be free from defect in material and workmanship. Except as otherwise set forth below, the duration of this Warranty shall be for TWELVE (12) MONTHS COMMENCING ON THE DATE OF DELIVERY OF THE PRODUCT TO THE ORIGINAL PURCHASER.

All current model loaders and backhoes are warranted for two (2) years from the date of delivery to the original purchaser.

The warranty periods for specific parts or conditions are listed below:

Part or Condition Warranted	Model Number	Duration (from date of delivery to the original purchaser)
	All units invoiced after 4/30/2012	
Gearbox components	BB48X, BB60X, BB72X, BB84X, BB600X, BB720X, BB840X, BB6000X, BB7200X, BB8400X, DS1260, DSO1260, DS1440, TS1680,	6 years
	BW15LH, BW126X, BW180X, BW126XHD, BW180XHD, BW1260X, BW1800X,	
	BW240X, BW240XHD, BW1620X, BW2400X	
	PHD25, PHD35, PHD65, PHD95, DS96, DS120, RCC42, RD990X, PRD6000, PRD7200, PRD8400, S15CD, S20CD, S22CD, S25CD, S27CD, S30CD, TC/R74, TC/R68, TC/R60, TBW144, TBW180, TBW204, TSG50, S12ED, S15ED, S18ED, S20ED	3 years (1 year if used in rental or commercial applications)
RDC54, RD60, RD72, TBW150C, TS/R60, TS/R52, TS/R44, HC48, HC54, HC60, HC72		
Blade spindles	RD990X, PRD6000, PRD7200, PRD8400, TBW144, TBW180, TBW204	3 years
Rust-through	BB600, BB720, BB840, BB6000, BB7200, BB8400, BW126X, BW180X, BW126XHD, BW180XHD, BW1260X, BW1800X, BW240, BW240HD, DS1260, DSO1260, DS1440, TS1680	10 years

Under no circumstances will this Warranty apply in the event that the product, in the good faith opinion of WOODS, has been subjected to improper operation, improper maintenance, misuse, or an accident. This Warranty does not apply in the event that the product has been materially modified or repaired by someone other than WOODS, a WOODS authorized dealer or distributor, and/or a WOODS authorized service center. This Warranty does not cover normal wear or tear, or normal maintenance items. This Warranty also does not cover repairs made with parts other than those obtainable through WOODS.

This Warranty is extended solely to the original purchaser of the product. Should the original purchaser sell or otherwise transfer this product to a third party, this Warranty does not transfer to the third party purchaser in any way. There are no third party beneficiaries of this Warranty.

WOODS makes no warranty, express or implied, with respect to engines, batteries, tires or other parts or accessories not manufactured by WOODS. Warranties for these items, if any, are provided separately by their respective manufacturers.

WOODS' obligation under this Warranty is limited to, at WOODS' option, the repair or replacement, free of charge, of the product if WOODS, in its sole discretion, deems it to be defective or in noncompliance with this Warranty. **The product must be returned to WOODS with proof of purchase within thirty (30) days after such defect or noncompliance is discovered or should have been discovered, routed through the dealer and distributor from whom the purchase was made, transportation charges prepaid.** WOODS shall complete such repair or replacement within a reasonable time after WOODS receives the product. **THERE ARE NO OTHER REMEDIES UNDER THIS WARRANTY. THE REMEDY OF REPAIR OR REPLACEMENT IS THE SOLE AND EXCLUSIVE REMEDY UNDER THIS WARRANTY.**

THERE ARE NO WARRANTIES WHICH EXTEND BEYOND THE DESCRIPTION ON THE FACE OF THIS WARRANTY. WOODS MAKES NO OTHER WARRANTY, EXPRESS OR IMPLIED, AND WOODS SPECIFICALLY DISCLAIMS ANY IMPLIED WARRANTY OF MERCHANTABILITY AND/OR ANY IMPLIED WARRANTY OF FITNESS FOR A PARTICULAR PURPOSE.

WOODS shall not be liable for any incidental or consequential losses, damages or expenses, arising directly or indirectly from the product, whether such claim is based upon breach of contract, breach of warranty, negligence, strict liability in tort or any other legal theory. Without limiting the generality of the foregoing, Woods specifically disclaims any damages relating to (i) lost profits, business, revenues or goodwill; (ii) loss of crops; (iii) loss because of delay in harvesting; (iv) any expense or loss incurred for labor, supplies, substitute machinery or rental; or (v) any other type of damage to property or economic loss.

This Warranty is subject to any existing conditions of supply which may directly affect WOODS' ability to obtain materials or manufacture replacement parts.

No agent, representative, dealer, distributor, serviceperson, salesperson, or employee of any company, including without limitation, WOODS, its authorized dealers, distributors, and service centers, is authorized to alter, modify, or enlarge this Warranty. Answers to any questions regarding warranty service and locations may be obtained by contacting:

Woods Equipment

A Blount International Company

2606 South Illinois Route 2
Post Office Box 1000
Oregon, Illinois 61061 USA

800-319-6637 tel
800-399-6637 fax
woodsequipment.com



ALITEC™

BMP®

CENTRAL FABRICATORS®

GANNON®

GILL®

WAIN-ROY®

WOODS®



WARRANTY

(Replacement Parts For All Models Except Mow'n Machine™
Zero-Turn Mowers and Woods Boundary™ Utility Vehicles)

Woods Equipment Company ("WOODS") warrants this product to be free from defect in material and workmanship for a period of ninety (90) days from the date of delivery of the product to the original purchaser with the exception of V-belts, which will be free of defect in material and workmanship for a period of 12 months.

Under no circumstances will this Warranty apply in the event that the product, in the good faith opinion of WOODS, has been subjected to improper operation, improper maintenance, misuse, or an accident. This Warranty does not cover normal wear or tear, or normal maintenance items.

This Warranty is extended solely to the original purchaser of the product. Should the original purchaser sell or otherwise transfer this product to a third party, this Warranty does not transfer to the third party purchaser in any way. There are no third party beneficiaries of this Warranty.

WOODS' obligation under this Warranty is limited to, at WOODS' option, the repair or replacement, free of charge, of the product if WOODS, in its sole discretion, deems it to be defective or in noncompliance with this Warranty. **The product must be returned to WOODS with proof of purchase within thirty (30) days after such defect or noncompliance is discovered or should have been discovered, routed through the dealer and distributor from whom the purchase was made, transportation charges prepaid.** WOODS shall complete such repair or replacement within a reasonable time after WOODS receives the product. THERE ARE NO OTHER REMEDIES UNDER THIS WARRANTY. THE REMEDY OF REPAIR OR REPLACEMENT IS THE SOLE AND EXCLUSIVE REMEDY UNDER THIS WARRANTY.

THERE ARE NO WARRANTIES WHICH EXTEND BEYOND THE DESCRIPTION ON THE FACE OF THIS WARRANTY. WOODS MAKES NO OTHER WARRANTY, EXPRESS OR IMPLIED, AND WOODS SPECIFICALLY DISCLAIMS ANY IMPLIED WARRANTY OF MERCHANTABILITY AND/OR ANY IMPLIED WARRANTY OF FITNESS FOR A PARTICULAR PURPOSE.

WOODS shall not be liable for any incidental or consequential losses, damages or expenses, arising directly or indirectly from the product, whether such claim is based upon breach of contract, breach of warranty, negligence, strict liability in tort or any other legal theory. Without limiting the generality of the foregoing, Woods specifically disclaims any damages relating to (i) lost profits, business, revenues or goodwill; (ii) loss of crops; (iii) loss because of delay in harvesting; (iv) any expense or loss incurred for labor, supplies, substitute machinery or rental; or (v) any other type of damage to property or economic loss.

This Warranty is subject to any existing conditions of supply which may directly affect WOODS' ability to obtain materials or manufacture replacement parts.

No agent, representative, dealer, distributor, service person, salesperson, or employee of any company, including without limitation, WOODS, its authorized dealers, distributors, and service centers, is authorized to alter, modify, or enlarge this Warranty.

Answers to any questions regarding warranty service and locations may be obtained by contacting:

ALITEC™
BMP®
CENTRAL FABRICATORS®
GANNON®
GILL®
WAIN-ROY®
WOODS®

WOODS®
Woods Equipment Company

Woods Equipment
A Blount International Company
2606 South Illinois Route 2
Post Office Box 1000
Oregon, Illinois 61061
800-319-6637 tel
800-399-6637 fax
woodsequipment.com