

leboulch



QUALITY & TRADITION



leboulch

JOSKIN

150

With over 100 and 50 years of experience respectively, Leboulch and JOSKIN put over 150 years of know-how at your service. Thanks to their combined strengths since 2012, the quality of the Leboulch machines has continued to improve to meet your ever-changing needs!





TABLE OF CONTENTS

6-11 COMPANY

Our history	6
Our factory	8
Our services	10



12-13 ADVANTAGE SERIES



14-29

MUCK SPREADERS



General points _____	14
HVS Evolution _____	16
GOLIATH Evolution _____	20
Equipment _____	26
Tyres _____	28

30-39

MONOCOQUE TIPPING TRAILERS

General points _____	30
GOLD2 XL _____	32
GOLD2 XXL _____	34
Equipment _____	36
Tyres _____	38



OUR HISTORY

Leboulch: 100 Years of Experience

Since 1921 and the first horse-trailed wooden agricultural cart, **Leboulch has accumulated experience and know-how in the construction of agricultural machinery.** With 80 years of technological development since the first factory was built in 1936, Leboulch has been able to establish its brand over the years: thousands of tipping trailers and muck spreaders have already been manufactured in La Vieille-Lyre (Normandy) and marketed throughout Europe.

1921

After the First World War, Mister Leboulch set up his **wheelwright workshop** in La Vieille-Lyre.



1946

The Leboulch company was then **at the forefront of muck spreaders.** It was the beginning of the production of steel chassis.



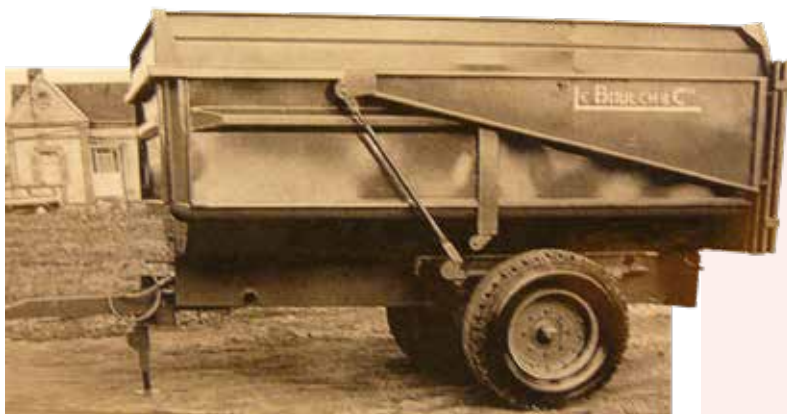

1960

The **first monocoque tipping trailers and sprung drawbars** marked the history of agricultural machinery. The first exports were to Europe and Africa.

1968

The historic **5,000-m²** factory was built. The number of employees reached **91** and the number of sales representatives **7**.



1990

The body design was standardized with “Le Boulch patented” **high-clearance swing doors** with reinforced arms.

Le Boulch

JOSKIN

2012-2013

Le Boulch was acquired by the JOSKIN group, giving a new impetus to the brand.

Major investments were made and all products were redesigned for the launch of the new “Evolution” range.

Today,

JLB le Boulch is part of a **strong industrial group** thanks to a standardised manufacturing process, modern production processes and an in-house design office. **Under JOSKIN group’s impetus**, JLB le Boulch’s facilities have been completely renovated to better meet the demands of the agricultural sector, thanks to an efficient internal operation.



OUR FACTORY

*At the Cutting Edge of **TECHNOLOGY***

In order to offer you the best agricultural machines, our factory is equipped with **state-of-the-art, high-precision tools** from the first to the last production stage.



In-house research and development



Cutting-edge production technology



Quality materials



Made in France



Know-how for over 100 years

A WELL-OILED MANUFACTURING PROCESS



RECEIPT AND STORAGE

Leboulch centralises the storage of components and deliveries to ensure a perfect, constant quality to the machines. Once the goods have been inspected and approved by the quality department, they are either dispatched to the production area or put into storage. The storage of the components is centralised thanks to 7 automated warehouses, which improve the after-sales service, with parts available within 48 hours.

CUTTING AND BENDING

After being inspected and stored, the steel sheets used for the tipping trailers and muck spreaders are cut continuously using ultra-fast and highly precise lasers. Thanks to the optimisation and automation of the cutting system, each steel sheet is optimised for a maximal profitability. Once cut, steel sheets are transferred to the bending area where they are processed by an automatic or semi-automatic press brake.

WELDING AND PAINTING

Parts are installed on a special jig and welded together, either manually or using state-of-the-art robots. Shot-blasting then ensures deep cleaning and roughening of the metal for a perfect paint adhesion. Two modern paint lines apply the brand's signature traditional red and hammered beige. For a protection against moisture and corrosion, Leboulch uses a 2K two-component polyurethane paint of industrial quality. After cooling, parts are transported by rail to the assembly or storage areas.

ASSEMBLY

Some part assemblies are pre-assembled upstream of the assembly line, thus avoiding assembly errors, guaranteeing an accurate individualised spare parts book, and saving time during the assembly. At Leboulch, there are several assembly lines: those for "à la carte" machines chosen by customers and those for mass production, such as the "Advantage" series.

QUALITY CONTROL AND SHIPPING

Once the assembly is completed, machines are brought to the test area for checking and inspection. An initial basic test enables the machine to be preset before moving on to a trial run with a tractor for a fine adjustment. When leaving the test area, Leboulch machines are ready for use. They are then dispatched by the JOSKIN truck fleet.



QUALITY PRECISION ORGANISATION



OUR SERVICES

*A Manufacturer **AT YOUR SERVICE***

With over 100 years of experience in the agricultural world, Leboulch now specialises in the manufacture of agricultural tipping trailers and muck spreaders. From production to repair, we do our utmost to provide you with quality machines. Our team criss-crosses all of France to guarantee **efficient pre-sales and after-sales services**. Leboulch invites all farmers, agricultural cooperatives, contractors and dealers to come and visit its facilities in La Vieille-Lyre.





CUSTOMISED ADVICE

To supply you with the ideal machine and avoid suffering the consequences of a wrong choice for many years, Leboulch bases its sales approach on a quality pre-sales service and a high transparency of the information over its products. Leboulch technicians support dealers during highly technical discussions about the machines.



QUALITY DEALER NETWORK

With a network of dealers throughout France, Leboulch guarantees a personalised service to its customers. Leboulch dealers are continuously trained, through very detailed "Dealers Trainings", in order to recommend you the machine that best meets your needs.



CONTINUOUS "SPARE PARTS" SERVICE

Based on the JOSKIN philosophy of "no parts, no repair", Leboulch understands the importance of spare parts. The 7 automated warehouses optimise storage and delivery of spare parts in the shortest possible time. Our warehousemen will work with you to identify the parts you need for your machine to work properly. For ease of reference, each Leboulch machine comes with a parts book and user manual.

GUARANTEED AFTER-SALES SERVICE

Our after-sales service is responsive and professional as well. Our technicians support the dealers during your machine start-up or for troubleshooting. We respond and intervene quickly to avoid a long machine downtime!



ADVANTAGE SERIES

*Full Equipment at **BEST PRICE!***

Following the example of JOSKIN's "Advantage" concept, Leboulch wanted to prove that it was possible to reduce the price of agricultural machinery without compromising quality. To overcome this budgetary constraint, the JOSKIN group relied on a "mass" production that was until then not used in the agricultural trailer industry. The models concerned by these series are indeed assembled on dedicated assembly lines so as to produce identical series of machines. Producing a model in large quantities gives access to more advantageous raw material purchase prices, a more cost-effective allocation of the workforce and a greater efficiency of automated machines. The resulting savings have then a direct impact on the selling price and allow us to deliver a high-tech product at the price of a standard one. Today, the "Advantages Series" accounts for **over 80% of Leboulch sales.**



TAKE **ADVANTAGE** SERIES OF IT!

- A** Evolving range of high-tech machines at best price
- A** Full standard equipment to perfectly meet your needs
- A** Maximum quality and reliability thanks to the series production
- A** Large stock available at the authorised dealers of the Leboulch network for a very fast delivery

DISCOVER

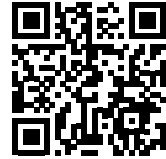

MUCK SPREADERS

2 Models | 14 Versions

DISCOVER



Leboulch offers **two ranges of single-axle muck spreaders** designed for quality crumbling and **intensive working conditions**. Leboulch's research department bases its analysis on the contemporary habits of farmers, who use ever more powerful tractors and load their trailers very generously. Leboulch muck spreaders are manufactured to optimise the spreading unit and structure to deal with higher strains in order to meet the needs of agricultural cooperatives, contractors and other large farms.



GENERAL POINTS

STURDINESS

- Full-length **folds**
- Floor and side walls in a single sheet of 4 mm **S420MC high tensile steel**
- **Overlapping assembly** of floor and side walls
- **Widened and lowered** body chassis
- **Reinforced** upper body edge strip

FINISHING

- **Series** production using **modern** manufacturing processes
- **Shot-blasting** of the body and chassis
- **Phosphating** cleaning
- **Double coat of paint** with electrostatic spray gun in booth

EASY MAINTENANCE AND OPERATION

- **Centralised** lubrication
- **Few** moving **parts**
- **HARDOX** steel knives
- **Reinforced** gearbox

OPTIONS

- Wide choice of **tyres** from leading brands (see p. 28)
- Limitation boards
- Flow proportional to the driving speed
- Guillotine door
- Hydraulic installation
- **And many other options possible** (see p. 26)

HIGHER SPREADING QUALITY

With its extensive experience in spreading, Leboulch is always looking for the best spreading quality, notably with large-diameter (900 mm) vertical beaters and lengthwise retractable blades. Spoon knives are also available for finer crumbling and increased width.

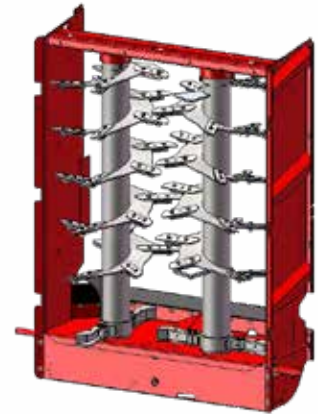

HVS evolution

Your OFF-ROAD SPREADER!

This **multipurpose lowered muck spreader with narrow body** offers a high loading capacity (from 7.8 to 17.44 m³) in order to maximise each transport. It offers **excellent stability** and **optimal safety** during work, thanks to the very good balance of the body on the axle and the excellent grip provided by the low centre of gravity, even on mountainous or steep terrain. The range includes **6 single-axle models**.



HVS Evolution: its Strengths

Lowered body for excellent stability and grip on slopes.

Monoblock body in special S420MC steel, with a full-length fold.

Leboulch beaters with regular spirals and retractable blades.

Moving floor drive by tractor hydraulics, manual adjustment of the flow.

**And much more...
Scan the QR code to
find out more!**



TECHNICAL DATA

	37S08	42S09	43S09	51S12	51S14	59S16
Volume with heap at door (m ³)	7.8	8.6	9.3	11.7	13.8	15.7
Volume with heap at beaters (m ³)	8.3	9.26	10.89	12.81	15.38	17.44
Body length (m)	3.7	4.2	4.3	5.1	5.1	5.9
Body width (under/above) (m)	1.7/1.3	1.7/1.3	1.91/1.50	1.91/1.50	1.91/1.50	1.91/1.50
Height under frame/ side height (m)	1.50/1.05	1.55/1.00	1.55/1.00	1.55/1.00	1.84/1.25	1.84/1.25
Axle type/number of axes/brakes (mm)	P70/8/ 350 x 60	P80/8/ 400 x 80	P90/8/ 400 x 80	P100/10/ 400 x 80	P100/10/ 406 x 120	P110/10/ 406 x 120
Axle track (mm)	2,100	2,100	2,200	2,200	2,200	2,200
GVW (kg)	7,600	9,300	10,700	12,100	13,620	15,150
Diameter/total height of the beaters (mm)	820/1,470	820/1,830	900/1,860	900/1,860	900/2,160	900/2,160
P.T.O./beater speed (rpm)	1,000/420	1,000/420	1,000/430	1,000/430	1,000/430	1,000/430
Number of blades per beater	19	22	20	20	24	24



MONOCOQUE BODY

The monoblock body was designed for an easy manufacturing and a sturdy construction. Side walls are made from a single **special S420MC steel** sheet, with a series of reinforcing folds at the inflection point: the wall is further reinforced since it is no longer subject to welding damage. This also improves sliding characteristics. The outer side reinforcements are also made from a single folded piece. They are therefore much thicker, and are continuously welded to the body, thus avoiding **breakage of the reinforcements at the inflection points of the body**. Hydraulic and electrical systems on the front of the muck spreader make the adjustment and maintenance even easier.



COMFORT

Regarding convenience, the hydraulic and electrical components of the HVS Evolution muck spreader are integrated in the front wall, with an easy access for **easy control and maintenance**. The sprung drawbar, which works flat for a high flexibility, also ensures driving comfort. The transmission is protected by a cam security on the P.T.O.-shaft and a free wheel on the spreading system. The grease nipples of the beater bearings are centralised outside the spreading frame.

HVS

evolution

VERSATILE, COMPACT AND EASY

SPREADING SYSTEM AND BEATERS

The spreading width varies from **6 to 12 m**, depending on the products to be spread. To achieve it, the **two Leboulch vertical beaters** rotate at a speed of 423 rpm and project the material to be spread with their bolted teeth. The length of the beaters has therefore been extended by 200 mm to work efficiently on the load heap. The 900 mm diameter of the spirals (820 mm for models 37S08 and 42S09) guarantees wide material transport and projection. The spirals are made of 10 mm thick **high tensile steel (S420MC)** and the interchangeable, reversible blades are made of Hardox. The maintenance is also easier since the beaters are mounted on interchangeable wear rings.



MOVING FLOOR

The moving floor of HVS muck spreaders consists of **two shipping chains** and **welded tubular slats**. Hydraulic drive is provided by the tractor (with optional mechanical or electric flow regulation) or by an independent hydraulic installation (electric regulation).

GOLIATH

evolution

Meets the **MOST DEMANDING PROFESSIONAL CRITERIA!**

The GOLIATH Evolution muck spreader is the **easy and reliable** basis for efficient and productive **intensive spreading works**. Particularly well suited to agricultural cooperatives and contractors, it is designed to withstand the toughest working conditions over time. The range includes **8 single- and double-axle models**, with loading capacities ranging from 10.7 to 24.3 m³. This base can furthermore be extended as required: COMPOSTAR composting unit, electronic control with or without DPA (flow proportional to the driving speed), swing door, etc.



GOLIATH Evolution: its Strengths

- Easy maintenance.
- Blades on wear rings.
- Hydraulic tensioner with safety device.
- COMPOSTAR spreading table available as an option.

**And much more...
Scan the QR code to
find out more!**



TECHNICAL DATA

	46S11	46S13	54S13	54S15	54S17	62S19	62D21	70D24
Volume with heap at door (m ³)	10.7	12.2	12.6	14.5	16.66	19	20.3	23
Volume with heap at beaters (m ³)	11.6	13.2	13.4	15.2	17.77	20.1	21.6	24.3
Body length (m)	4.6	4.6	5.4	5.4	5.4	6.2	6.2	7
Body width (under/above) (m)	1.98/1.5	1.98/1.5	1.98/1.5	1.98/1.5	1.98/1.5	1.98/1.5	1.98/1.5	1.98/1.5
Height under frame/side height (m)	1.36/1	1.66/1.2	1.36/1	1.66/1.2	1.79/1.4	1.79/1.4	1.96/1.6	1.96/1.6
Axle type/ number of axes/ brakes (mm)	130/10/ 406 x 120	130/10/ 406 x 120	130/10/ 406 x 120	130/10/ 406 x 120	130/10/ 406 x 120	130/10/ 406 x 120	Tandem with rods 2x130/10/ 400 x 80	Tandem with rods 2x130/10/ 400 x 80
Axle track (mm)	2,200	2,200	2,200	2,200	2,200	2,200	2,200	2,200
GVW (kg)	10,230	11,600	12,000	13,100	14,610	15,840	21,000	23,550
Diameter/total height of the beaters (mm)	900/1,760	900/1,960	900/1,760	900/1,960	900/2,160	900/2,160	900/2,360	900/2,360
P.T.O./beater speed (rpm)	1,000/430	1,000/430	1,000/430	1,000/430	1,000/430	1,000/430	1,000/430	1,000/430
Number of blades per beater	19	22	19	22	25	25	28	28



REINFORCED MONOCOQUE BODY

The GOLIATH convinces first and foremost with its body design. Each wall, floor and upper body edge strip is made in one piece from a **single steel sheet**, eliminating deformations and strength changes caused by welding (monoblock design). Made from **high tensile steel (S420MC)**, the body of the GOLIATH muck spreader is relatively low for easy loading. The widened, rounded upper part helps the load to go down, while the vertical part at the bottom limits the compression rate of the lower volume, guaranteeing an even material feed, a very clean body after emptying, and an even **feeding of the beaters**. This homogeneous feeding is also fostered by a sturdy moving floor with shipping or "Vaucanson" chains, which are tensioned by a closed hydropneumatic circuit, with mechanical relief in reverse rotation.

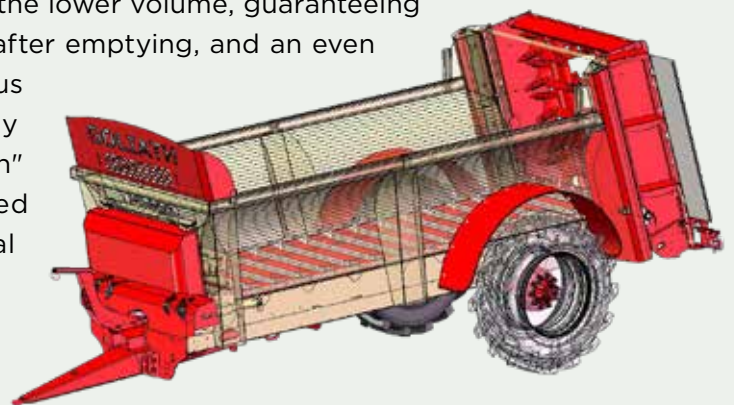



GOLIATH

evolution

STURDY, RELIABLE AND EASY

SPREADING SYSTEM AND BEATERS

The spreading width varies from **8 to 16 m**, depending on the products to be spread. To achieve it, the two Leboulch vertical beaters rotate at a speed of **423 rpm** and project the material to be spread with their bolted teeth. The Leboulch beaters are renowned for their excellent crumbling qualities. This is made possible by the use of 10 mm thick high tensile steel spirals, whose 900 mm diameter guarantees a wide overlapping area. The specific distribution of the knives (interchangeable, reversible and made of Hardox steel) and the lower blades also contribute to the crumbling quality.

COMPOSTAR System

As an option, this system offers an even more uniform distribution for all types of manure. It includes 2 horizontal beaters with bolted digging blades, 2 side boards to compost in a stationary way or at the field edge and a canopy that can be lifted hydraulically by a double-acting valve of the tractor or an electrohydraulic function. A manually-adjustable plate also makes it possible to adjust the product drop point on the 2 discs (Ø 900 mm) of the spreading table with reinforced monobloc beam, further simplifying maintenance.





EASE OF USE

The Leboulch GOLIATH Evolution muck spreader offers ease of use and an optimal safety. The **grates to check the load** and the moving floor gearboxes reassure the driver. The **hydraulic tensioners** of the moving floor balance the load peaks and stop the spreading process if the system pressure is insufficient. The **integral hoods** and the **upper front carter**, the **galvanised side boards at the back** and the **mudguards** protect the muck spreader and tractor. Even the rear lights are protected at work by an automatic device that folds them as soon as the moving floor is activated. In addition, the moving floor speed is adjusted by an **electrohydraulic control of the oil flow**.

RELIABILITY AND MAINTENANCE

Regarding ease of maintenance, the focus is laid on **sturdiness** and **interchangeability**. Hydraulic and electrical components protected under the front hood with high accessibility, Ø 45 mm drive shaft, cam clutch on the P.T.O.-shaft, freewheel on the spreading system, side lubrication of the beater bearings, wide bearing protection, moulded gearwheels, built-in door cylinders, ducts for hydraulic and electrical lines.... are just some of the features developed on the Goliath Evolution muck spreader **to ensure the machine durability**.



MOVING FLOOR

The moving floor of the GOLIATH muck spreaders consists of **2 grade 80 shipping chains (Ø 14 or Ø 16 mm) and bolted tubular slats**. The hydraulic drive is provided by the tractor or an independent hydraulic installation. The LB300 electric control box is part of the standard equipment of the GOLIATH muck spreaders. Two wear bars are also present along the length of the body floor to limit the friction of the moving floor slats on the floor steel sheet.



EQUIPMENT

Over 35 OPTIONS Available!

For even higher comfort and flexibility, Leboulch muck spreaders can be equipped with options that will give you a **quality finish that meets your expectations!** Discover them all by scanning these QR codes!

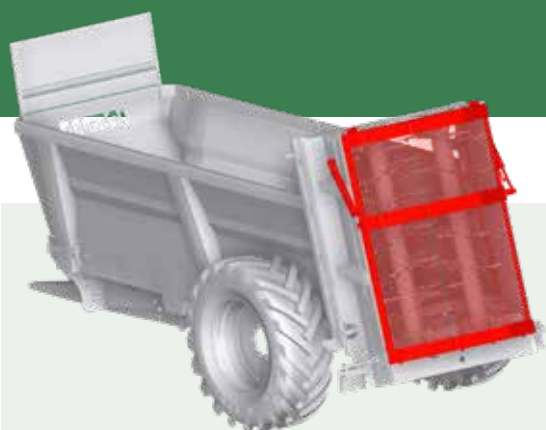

SWISS CANOPY

Protective grating for an optimal safety.

Available on HVS and Goliath.

GUILLOTINE DOOR with electrical safety device

Regulation of material supply to the beaters.

Available on HVS and Goliath.



HYDRAULIC INSTALLATION

Hydraulic autonomy of the spreader.

Available on HVS and Goliath.



Vaucanson Chain of "RUBIG" TYPE

Self-cleaning 20 mm diameter chain, ideal for heavy-duty work and contractors. Its design enables reversing, which is not the case with a traditional Vaucanson chain.

Available on HVS and Goliath.

Steel EXTENSION

200 mm steel extension to increase volume.

Available on HVS and Goliath.



Hydraulic SIDE BOARD

Possibility to spread at the field edge via a fixed left or right-hand position.

Available on HVS and Goliath.

DPA (flow proportional to the driving speed)

Automatic adaptation of the moving floor speed according to the driving speed of the muck spreader to ensure a constant spreading flow.

Available on HVS and Goliath.



DPA (proportional flow) Control with DYNAMIC WEIGHING SYSTEM

The weighing system continuously communicates the quantity of material in the muck spreader to the DPAE control system. Thanks to this information, the moving floor speed can be controlled even more precisely, and the quantity of material spread corresponds at all times to the given target in t/ha.

Available on Goliath.

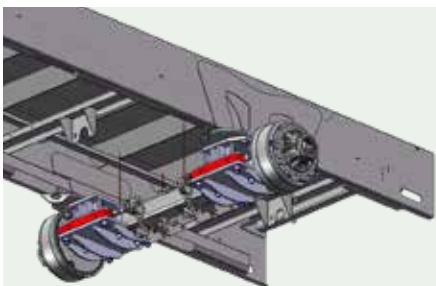

TYRES

Choose from over **30 TYRE TYPES**

To provide you with the perfect machine for your needs, we offer a **wide choice of tyres.**



Type	Profile	Picture no.	Quality	Dimensions (mm)		Max. load per wheel at 40 km/h (kg)	Max. pressure (bar)	Available on	
				Height	Width			HVS	Goliath
Available on single-axle models									
23.1x26 14PR (Alliance) 156A8	A347	19	New	1,605	587	4,800	2.4	Yes	No
620/75R26 (Alliance) 167A8	A360	22	New	1,590	625	5,450	3.2	Yes	Yes
18.4/15x30 (Alliance) 152A8	A324	28	New	1,550	467	4,260	3.2	Yes	No
650/75R32 (Alliance) 175A8	AGRITERRA 03	46	New	1,623	697	6,830/9,660	2/4	No	Yes
650/75R32 (BKT) 172A8	AGRIMAX TERIS	22	New	1,789	655	2,900/6,300	0.8/3.2	Yes	Yes
650/75R32 (BKT) 172A8	AGRIMAX RT 600	35	New	1,785	645	6,300	3.2	Yes	Yes
650/75R32 (Alliance) 175A8	A360	22	New	1,800	625	6,900	3.7	Yes	Yes
650/75R32 (Mitas) 172A8	AC70G	27	New	1,795	650	5,020	2	Yes	Yes
460/85R34 (Alliance) 157A8	A846	27	New	1,637	479	4,125	3	Yes	Yes
18.4/15x34 (Alliance) 153A8	A324	28	New	1,650	467	4,380	3	Yes	Yes
520/85R38 (Mitas) 169A8	AC85	27	New	1,877	539	5,800	3.6	No	Yes
580/70R38 (Alliance) 170A8	A370	23	New	1,817	577	6,000	2.8	No	Yes
650/85R38 (BKT) 176A8/173D	AGRIMAX FORTIS	27	New	2,060	680	7,100	2.4	No	Yes
Available on double-axle models									
560/60R22.5 14PR (Alliance) 156A8	A885	45	New	1,230	555	6,800	4	No	Yes
560/60R22.5 (Trelleborg) 161D	Twin Radial	8	New	1,240	552	3,930/6,290	2/4	No	Yes
600/55R22.5 (Alliance) 165D	A380	7	New	1,245	600	6,890	4	No	Yes
600/55R26.5 (Alliance) 165E	A380	7	New	1,345	625	5,670/7,470	2.5/4	No	Yes
600/55R26.5 (Michelin) 170D	TRAILXBIB	55	New	1,353	624	7,750	3.2	No	Yes
650/55R26.5 STB (BKT) 169D	FL 630 SUPER	11	New	1,389	645	7,890	4	No	Yes
650/55R26.5 (Alliance) 167E	A380	7	New	1,360	645	7,900	4	No	Yes
650/65R26.5 STB (BKT) 174D	FL 630 SUPER	11	New	1,519	645	9,115	4	No	Yes
650/65R26.5 (Nokian) 174D	Country King	9	New	1,518	645	9,150	4	No	Yes
710/50R26.5 (BKT) 170D	RIDEMAX FL 693 M	43	New	1,383	727	8,160	4	No	Yes
710/50R26.5 (Mitas) 170D	AGRITERRA 02	10	New	1,388	737	5,766/8,160	2/4	No	Yes
710/50R26.5 (Michelin) 176D	TRAILXBIB	55	New	1,380	739	9,150	3.2	No	Yes

MONOCOQUE TIPPING TRAILERS

2 Models | 14 Versions



Leboulch monocoque agricultural tipping trailers are available in several models ranging from **16 to 32 tonnes** GVW and 1.2 m or 1.5 m height. They are made from S420MC high tensile steel, which has enabled us to create a **light body** with fewer reinforcements that remains **sturdy** thanks to the full-length folds. These beige and red tapered bodies are wider at the bottom to lower the centre of gravity and facilitate emptying. Additional features include a door seal, a parabolic leaf suspension, a grain chute with adjustable opening and a large sight window.



GENERAL POINTS

STURDINESS

- **Overlapping assembly** of floor and side walls
- **Omega reinforcements** under the posts
- **Widened and lowered** body chassis
- Body floor in **4 mm** high tensile steel.
- Tubular chassis in **high tensile steel**
- **10 mm thick** tubular chassis stringers

FINISH

- Pilot valves to hold the door **safely**
- **Flashing beacon**
- **Polyurethane paint** after shot-blasting and phosphating

COMFORT

- **Watertight, lockable door**
- **Sight window**
- **180° folding parking stand**
- **Ladder**
- **Horizontal sprung drawbar**

OPTIONS

Many options available to adapt your tipping trailer to the legislation or for even greater comfort (see p. 36).

LIGHT TAPERED BODY

Thanks to the use of high tensile steel and a body design based on successive folds, Leboulch has significantly reduced the weight of its tipping trailers. The tapered shape of the body (2.25 m inside width at the front, 2.3 m at the rear) makes it easier to unload. These two features ensure a **greater stability to the machine when tipping**.

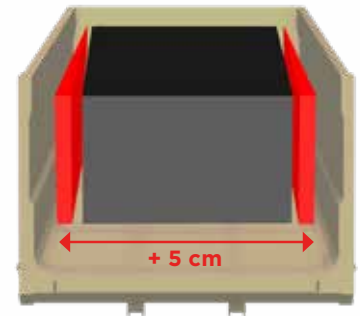

RUNNING GEAR

Mechanical suspensions (A) with spring, multi or parabolic leaves stand for **ease of use and operation**. Bogies (B) offer a high clearance **increasing the crossing capacity** and load distribution in difficult conditions. Tandems and tridems represent the best compromise for both road and agricultural use. The free- or self-steering axle systems make manoeuvring easier and reduce tyre wear.

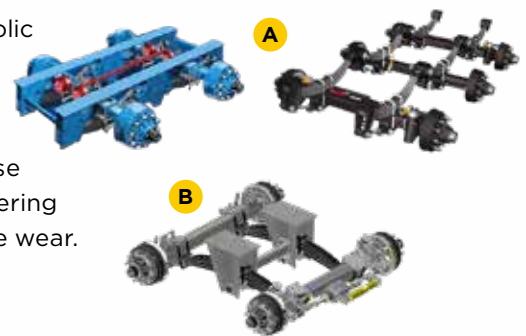

GOLD² XL

STURDY, RELIABLE AND EASY

SCAN ME



Available in **single- or double-axle versions**, Gold2 XL tipping trailers offer payload capacities **from 11 to 18 tonnes**, with a body height of 1.2 m. Functional, sturdy and reliable, they meet the demands of the most demanding users requiring a reliable tipping trailer for the transport of seeds, fertilizers, bulk materials...



Specific equipment on 58D22 and 62D24 XL HIGH-TIPPING TRAILERS
(replacing standard equipment)

- 2 grain hatches (width: 500 mm).
- 2 removable chutes.
- Tipping system with compressor.
- Lifting by tractor hydraulics.



TECHNICAL DATA

	47S16	53S16	53D19	58D22	62D24
Indicative payload (kg) (excl. option(s))	11,400	11,320	13,470	15,360	17,695
GVW (kg)	15,400	15,900	19,100	21,400	23,985
Indicative empty weight (kg)	4,000	4,580	5,630	6,040	6,290
Body length (m)	4.7	5.3	5.3	5.8	6.2
Body width (front/rear) (m)	2.25/2.30	2.25/2.30	2.25/2.30	2.25/2.30	2.25/2.30
Body height (m)	1.2	1.2	1.2	1.2	1.2
Volume (m ³)	13	14.5	14.5	16	17
Axle type	Single P1 x 100 / 8	Single P1 x 110 / 10	Bogie P2 x 100 / 8	Bogie P2 x 100 / 8	Bogie P2 x 110 / 10
Track (mm)	2,000	2,000	2,000	2,000	2,000
Brakes (mm)	400 x 80	400 x 80	350 x 90	400 x 80	400 x 80
Tipping cylinder volume (l)	17	20	20	26	36
	Specific equipment on 47S16 XL and 53S16 XL: rigid drawbar and hydraulic parking stand		Specific equipment from 53D19 XL to 62D24 XL: sprung drawbar and hydraulic parking stand		

Understand the model names:

- The first 2 digits correspond to the body length (in dm).
- The letter indicates the number of axles: S = single axle, D = two axles, T = three axles.
- The last 2 digits indicate the GVW (in t).

Example: model 53D19 is a tipping trailer with a body length of 5.3 m, two axles and a 19 t GVW.

GOLD² XXL

Designed for **INTENSIVE USE**

SCAN ME



The GOLD2 XXL tipping trailer is a vehicle specialised in the transport of large volumes and dense materials, thanks to its **1.5 m high monoblock side walls**. These provide the trailer with a **high resistance to intensive use**. Available in double- or triple-axle versions, this tipping trailer perfectly meets the most demanding requirements of farms, agricultural cooperatives and contractors.

Sight window (with perspex plate and galvanised protective grating)

Tapered monocoque body (S420MC high tensile steel - 4 mm)

1-part hydraulic door (with seal)

Galvanised access ladder

Hydraulic brakes

Sprung drawbar

Hydraulic parking stand

Chassis made of 300 x 100 x 10 mm tubes

LED flash light (flashing beacon on lighting)

500 x 500 mm central grain chute

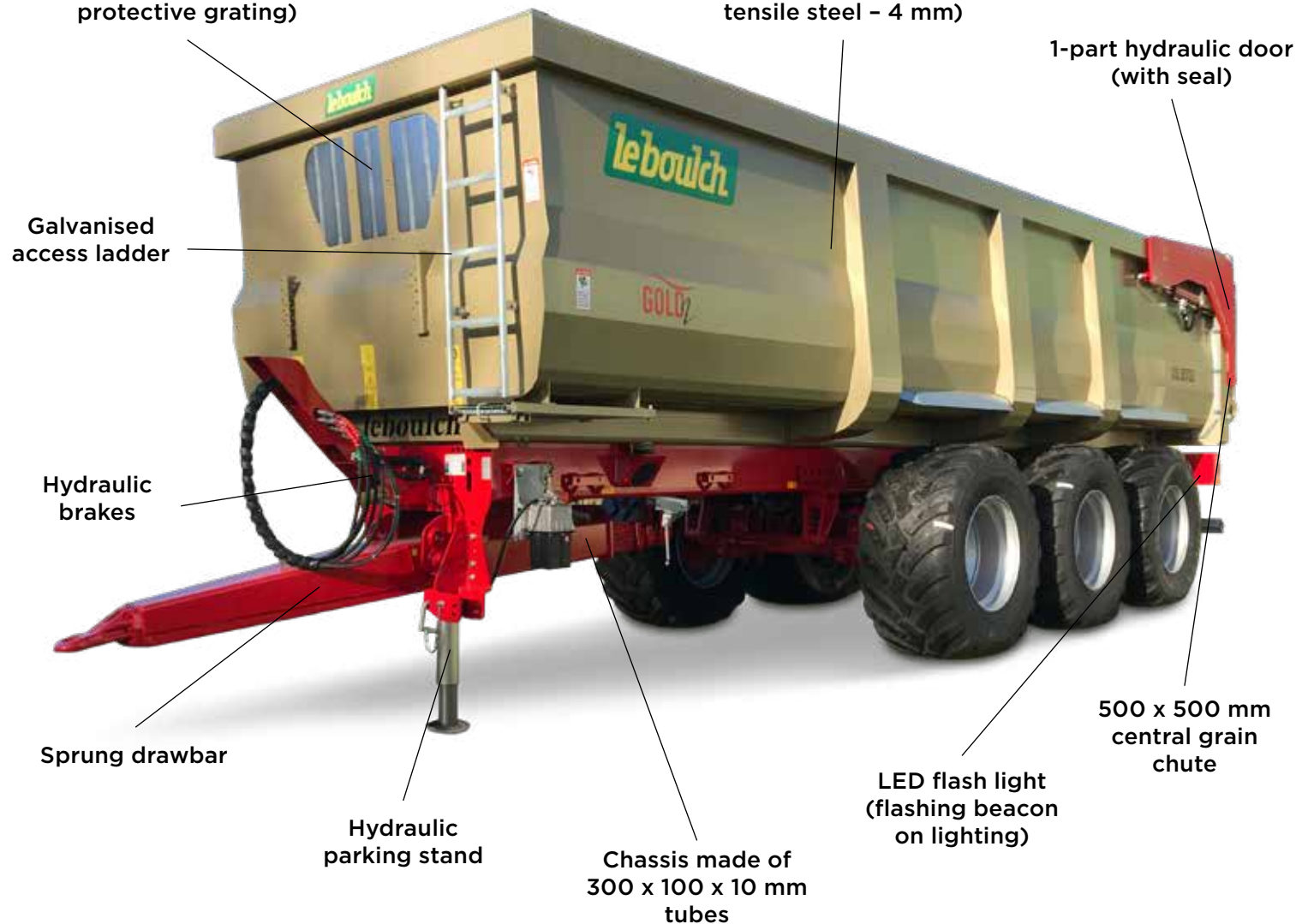

Specific equipment on 58D22, 62D24, 73D26 and 73D29 XXL HIGH-TIPPING TRAILERS (replacing standard equipment)

- 2 grain hatches (width: 500 mm).
- 2 removable chutes.
- Tipping system with compressor.
- Lifting by tractor hydraulics.



TECHNICAL DATA

	53D19	58D22	62D24	67D24	67D26	73D26	73D29	79T32	85T32
Indicative payload (kg) (excl. option(s))	13,000	15,260	17,445	16,635	18,950	18,310	20,870	22,410	21,810
GVW (kg)	19,100	21,400	23,985	23,985	26,300	26,300	28,960	32,000	32,000
Indicative empty weight (kg)	6,100	6,140	6,540	7,350	7,350	7,990	8,090	9,590	10,190
Body length (m)	5.3	5.8	6.2	6.7	6.7	7.3	7.3	7.9	8.5
Body width (front/rear) (m)	2.25/2.3	2.25/2.3	2.25/2.3	2.25/2.3	2.25/2.3	2.25/2.3	2.25/2.3	2.25/2.3	2.25/2.3
Body height (m)	1.5	1.5	1.5	1.5	1.5	1.5	1.5	1.5	1.5
Volume (m ³)	18.5	20	21.5	23	23	25	25	27	29
Axle type	Bogie P2 x 100 / 8	Bogie P2 x 100 / 8	Bogie P2 x 110 / 10	Bogie P2 x 110 / 10	Free-steering tandem with rods 2 x 130 / 10	Free-steering tandem with rods 2 x 130 / 10	Free-steering tandem with rods 2 x 150 / 10	Free-steering tridem with rods 3 x 130 / 10	Free-steering tridem 3 x 130 / 10
Track (mm)	2,000	2,000	2,000	2,000	2,100	2,100	2,100	2,100	2,100
Brakes (mm)	350 x 90	400 x 80	400 x 80	400 x 80	406 x 120	406 x 120	406 x 120	400 x 80	400 x 80
Tipping cylinder volume (l)	20	26	36	36	36	53	53	62	62

Specific equipment from 53D19 XXL to 62D24 XXL: tipping system with direct connection to the tractor

Specific equipment from 67D24 to 85T32 XXL: tipping system with 1,000 rpm compressor (hydraulic lowering)

Specific equipment from 67D26 to 85T32 XXL: bolted eyelet and rear free-steering axle

Understand the model names:

- The first 2 digits correspond to the body length (in dm).
- The letter indicates the number of axles: S = single axle, D = two axles, T = three axles.
- The last 2 digits indicate the GVW (in t).

Example: model 53D19 is a tipping trailer with a body length of 5.3 m, two axles and a 19 t GVW.

EQUIPMENT

Over 40 OPTIONS Available!

For even higher comfort and flexibility, Leboulch tipping trailers can be equipped with options that will give you a **quality finish that meets your expectations!** Discover them all by scanning this QR code!

SCAN ME



HIGH-TIPPING TRAILER

This option allows the body to be raised to facilitate the handling of bulk products, such as potatoes or fertilizer.

COMPRESSOR: 60 or 85 l/min (1,000 rpm)

The compressor option allows the tipping trailer to be used independently of the power or oil volume of the tractor.



DUAL BRAKES (hydraulic and air brakes)

Leboulch offers the 2 types of braking systems available on the tractor market.



THERMOPLASTIC MUDGUARDS

Recommended for on-road use, the thermoplastic mudguard option limits splashing onto the tractor or tipping trailer.

Wide choice of EXTENSIONS

To best meet your needs, Leboulch offers 300, 500 and 700 mm extensions that can be combined up to 1 m.



2 GRAINS HATCHES/REMOVABLE CHUTE

This equipment allows you to select the unloading side: left or right. This makes it easier to empty the entire load: no material remains on the side walls.

LOAD TRANSFER

The load transfer avoids shocks when tipping and ensures a perfect stability.

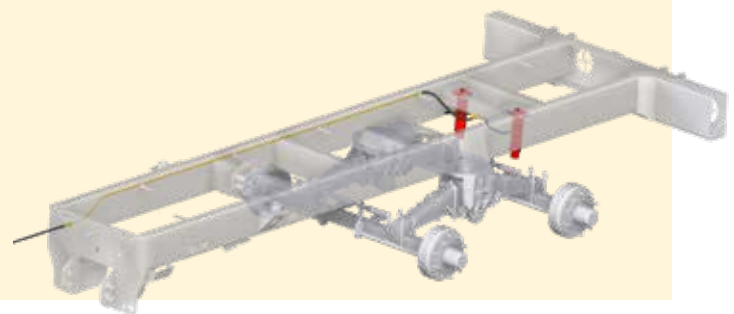

Ø 80 MM SCHARMÜLLER HITCH

This type of hitch improves driving comfort and allows a load transfer of up to 4 tonnes.

TYRES

Choose from nearly **30 TYRE TYPES**

To provide you with the perfect machine for your needs, we offer a **wide choice of tyres** for all Gold2 models (XL and XXL).



MONOCOQUE TIPPING TRAILERS

Type	Profile	Picture no.	Quality	Dimensions (mm)		Max. load per wheel at 40 km/h (kg)	Max. pressure (bar)
				Height	Width		
550/60-22.5 16PR (BKT) 169A8	Flotation 648	5	New	1,240	550	5,800	3.2
550/60-22.5 16 PR (BKT) 167A8	V-Line	5	New	1,240	550	5,450	2.8
560/60R22.5 STB (BKT) 161D	FL 630 SUPER	11	New	1,244	543	6,290	4
560/60R22.5 (BKT) 172A8/161D	Flotation 630	11	New	1,244	543	6,300	4
560/60R22.5 STB (Alliance) 164D	A885	45	New	1,230	555	6,800	4
560/60R22.5 (Mitas) 165D	AGRITERRA 02	10	New	1,247	567	7,000	5
560/60R22.5 (Michelin) 166D	TRAILXBIB	55	New	1,242	542	6,825	3.2
600/50R22.5 (BKT) 170A8/159D	FL 630 Plus	11	New	1,172	611	6,000	4
650/50R22.5 (BKT) 163D	FL 693	43	New	1,222	645	6,630	4
24R20.5 (Michelin) 176F	TL XS	2	New	1,374	602	8,195	4
580/65R22.5 (Alliance) 166D	Flot 885	45	New	1,315	574	7,210	4
580/65R22.5 (Vredestein) 166D	Flotation Trac	16	New	1,300	585	7,208	4
600/55R22.5 (Alliance) 165D	380	7	New	1,245	600	6,890	4
600/55R26.5 STB (BKT) 165D	FL 630 SUPER	11	New	1,333	611	7,005	4
600/55R26.5 (BKT) V-Flexa 167D	V-Flexa	53	New	1,342	615	7,030	4
600/55R26.5 (Alliance) 165D	A885	45	New	1,345	625	7,004	4
600/55R26.5 (Alliance) 165E	A380	7	New	1,345	625	5,670/7,470	2.5/4
600/55R26.5 (Mitas) 165D	AGRITERRA 02	10	New	1,335	626	4,950/7,000	2/4
600/55R26.5 (Michelin) 170D	TRAILXBIB	55	New	1,353	624	7,750	3.2
600/55R26.5 (Nokian) 165D	Country King	9	New	1,333	600	7,004	4
600/55R26.5 (Nokian) CT TL 169D	CT TL	48	New	1,334	610	7,890	5
650/55R26.5 STB (BKT) 169D	FL 630 SUPER	11	New	1,389	645	7,890	4
650/55R26.5 (BKT) 169D	FL693M	43	New	1,389	645	7,890	4
650/55R26.5 (Alliance) 167E	380	7	New	1,360	645	7,900	4
650/55R26.5 (Mitas) 169D	AGRITERRA 02	10	New	1,383	653	7,888	4
600/55R26.5 (Vredestein) 165D	Flotation Trac	16	New	1,350	620	7,005	4
650/55R26.5 (Nokian) 177D	CT	48	New	1,389	645	7,900	4
650/60R26.5 (Alliance) 173D	A380	7	New	1,450	660	6,610/8,840	2.5/4



JLB leboulch

Route de Guernanville
27330 La Vieille-Lyre (France)

Tel.: 02 32 30 67 47

E-mail: info@leboulch.com

www.leboulch.com

