

Technical sheet :

# **MLA-T 516-75 H**

---



Capacities		Metric
Static tipping load with bucket (straight)		3535 kg
Static tipping load with forks (straight)		2732 kg
Static tipping load with forks (full turn)		2000 kg
Max. payload with forks as per EN 474-3 (80%)		1600 kg
Max. height of bucket pivot point	h35	5.03 m
Max. lifting height (below forks)	h3	4.84 m
Max. outreach	r1	3.30 m
Weight and dimensions		
Unladen weight (with forks) with 4-post canopy		5543 kg
Ground clearance	m4	0.31 m
Overall length to carriage (without hitch)	l3	4.95 m
Overall width of 4 posts canopy	b22	1.28 m
Overall cab width	b4	1.28 m
Overall width (over tyres)	b1	1.74 m
Overall height with 4 posts canopy	h38	2.48 m
Articulation angle		44 °
Engine		
Engine brand		Deutz
Environmental norm		Stage 3B
Engine model		TD_3_6_L4
Number of cylinders / Capacity of cylinders		4 - 3600 cm <sup>3</sup>
I.C. Engine power rating / Power (kW)		74.30 Hp / 55.40 kW
Max. torque / Engine rotation		330 Nm / 1600 rpm
Engine cooling system		2 radiators water + hydraulic oil
Transmission		
Transmission type		Hydrostatic
Number of gears (forward / reverse)		2 / 2
Travel speed (laden)		20 km/h
Max. travel speed (may vary according to applicable regulations)		30 km/h
Differential lock		Machine Lock Rear & front
Parking brake		Manual
Hydraulics		
Hydraulic pump type		Gear pump
Hydraulic flow - Pressure		70 l/min / 200 Bar
High-Flow Option (l/min)		110 l/min
Drive hydraulic system pressure		380 Bar
Tank capacities		
Hydraulic oil		74 l
Fuel tank		102 l
Noise and vibration		
Vibration to whole hand/arm		< 2.50 m/s <sup>2</sup>
Miscellaneous		
Safety cab homologation		ROPS - FOPS cab (level 1)

## Options / Finishing

S : Standard / O : Optional / - : Not available

	Essential	Classic	Premium
Lifting function			
Boom suspension	O	O	S
Easy Connect System (E.C.S.)	S	-	-
Hydraulic attachment locking	S	S	S
Operator station			
Adjustable and telescopic steering column	S	S	S
Air conditioning with manual adjustment	-	-	S
Air pre-filter	S	-	-
Air suspension seat	-	O	S
Canopy	S	-	-
Closed cab with heating	-	-	S
Floor mat	S	S	S
Manual air conditioning	-	O	-
Suspension Seat - Mechanical	S	-	-
Tuner car radio (50 W)	-	S	S
Motorization/Power			
Attachment hydraulic line	S	S	S
Continuous flow hydraulics	S	S	S
Hand throttle	S	S	S
Self cleaning air prefilter	-	S	S
Speed control	O	O	S
Third speed	O	O	S
Lighting			
Complete road lighting	O	-	S

Flat LED rotating beacon (-71 mm)

Front and rear LED work lights on cab (x4 : 2 front + 2 rear)

Front and rear work lights on cab (x4: 2 front + 2 rear)

**Essential**

0

0

S/O\*\*

**Classic**

0

0

S

**Premium**

0

S

-

# Load chart

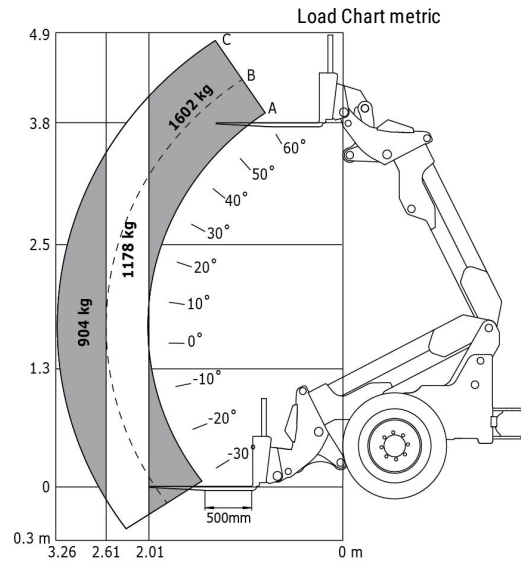

# Dimensional drawing

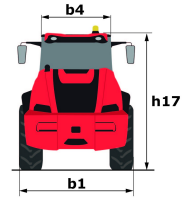
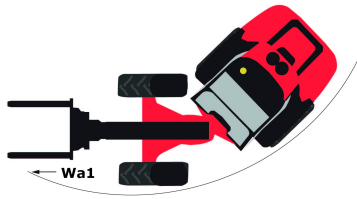
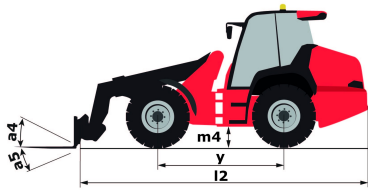

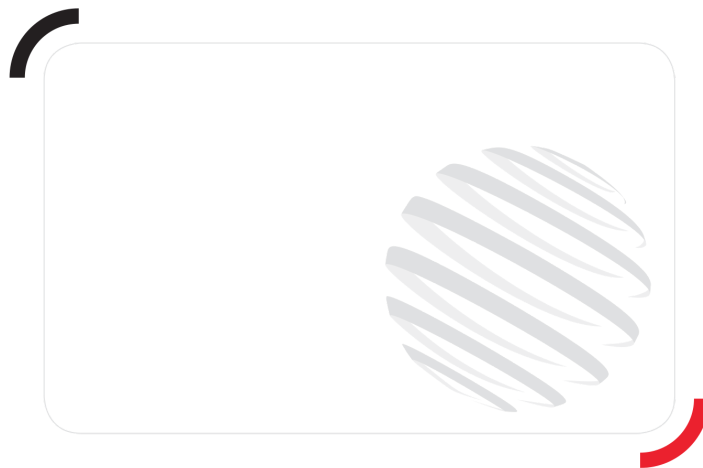

Siège Social

430 rue de l'Aubinière - 44150 Ancenis Cedex - France

Tel: +33(0)2 40 09 10 11 - Fax: +33 (0)2 40 09 10 97

[www.manitou.com](http://www.manitou.com)



This brochure describes versions and configuration options for Manitou products which may be fitted with different equipment. The equipment described in this brochure may be standard, optional or not available depending on version. Manitou reserves the right to change the specifications shown and described at any time and without prior warning. The manufacturer is not liable for the specifications given. For more information, contact your Manitou dealer. Non-contractual document. Product descriptions may differ from actual products. List of specifications is not comprehensive. The logos and visual identity of the company are the property of Manitou and may not be used without authorisation. All rights reserved. The photos and diagrams contained in this brochure are provided for information only.

MANITOU BF SA - Limited company with board of directors - Share capital: 39,668,399 euros - 857 802 508 RCS Nantes