



**PRO**

**PRO 850**

*Tome 2 – Volume 2*

*Teil 2 – Tomo 2*

7R20230

Edition 4



LIRE ATTENTIVEMENT CE MANUEL AVANT LA MISE EN SERVICE DE VOTRE ZODIAC.  
CAREFULLY READ THIS MANUAL BEFORE OPERATING YOUR ZODIAC.  
LEGGERE ATTENTAMENTE PRIMA DE INIZIARE IL MONTAGGIO DEL VOSTRO ZODIAC.  
VOR INBETRIEBNAHME IHRES ZODIAC VORLIEGENDES HANDBUCH AUFMERKSAM LESEN.  
LEER CUIDADOSAMENTE ESTE MANUAL ANTES DE PONER EN SERVICIO SU ZODIAC.



**Manuel du Propriétaire  
Tome 2**

**PRO 850**

# TOME 2

## DESCRIPTION - FLOTTEUR

### SYSTEME DE PROPULSION





### INSTALLATION ET CIRCUITS

## SOMMAIRE

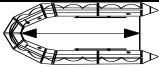

	PAGE
⇒ I - DESCRIPTIONS GENERALES	
I-1-Caractéristiques techniques -----	3 - 6
I-2-Descriptif technique-----	6
I-3-Localisation des éléments-----	7 - 8
I-4-Manutention -----	9
⇒ II - FLOTTEUR	
II-1-Montage du flotteur sur la coque-----	10
II-2-Fixation de la bavette-----	11
-	
II-3-Système de gonflage-----	12 - 13
II-4-Pression -----	14 - 15
⇒ III - SYSTEME DE PROPULSION	16
⇒ IV - INSTALLATIONS ET CIRCUITS	
IV-1-Carburant -----	17 - 20
IV-2-Electricité-----	21 - 35
IV-3-Assechement-----	36 - 37
IV-4-Direction-----	38
IV-5-Incendie-----	38
IV-6-Mouillage / Amarrage-----	39
⇒ V – SIGNALETIQUE	
V-1-Position des autocollants de sécurité et plaques d'immatriculation-----	40
V-2-Descriptif des autocollants de sécurité et plaques d'immatriculation-----	41 - 42
⇒ VI – EMBLACEMENT / MONTAGE ACCESSOIRES OPTIONNELS	
VI-1-Emplacement console -----	43 - 44
VI-2-Emplacement siège / bolster-----	44
VI-3 Emplacement rollbar-----	45
VI-4 Emplacement mât de ski / dossier arrière -----	45
VI-5 Emplacement TTOP-----	46



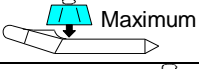
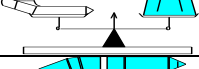

# DESCRIPTION - Caractéristiques techniques

## I-1-CARACTERISTIQUES TECHNIQUES

Dimensions		
	(m)	8.5
	(ft)	27'10"
	(m)	7.45
	(ft)	24'5"
	(m)	3
	(ft)	9'10"
	(m)	1.85
	(ft)	6'
	(m)	0.6
	(ft)	1'11"

Catégorie de conception	
 (Directive 94/25/CE)	B / C

Capacité			
 (ISO)		B=10	C=20
 Maximum	<b>Kg</b> <sup>(1)</sup>	2050	2800
	<b>lb.</b> <sup>(1)</sup>	4519	6173
	<b>Kg</b> <sup>(2)</sup>	1350	1350
	<b>lb.</b> <sup>(2)</sup>	2976	2976
 <b>Compartment</b>		7	

Motorisation				
Longueur de l'arbre			MONOMOTEUR	BI-MOPTORISATION
			XXL	XL
	Puissance MINI recommandée	CV <sup>(3)</sup>	250	2 x 175
		KW <sup>(3)</sup>	187	2 x 131
	Puissance MAXI recommandée	CV	300	2 x 225
		kW	225	2 x 166
	Puissance MAXI autorisée	CV <sup>(3)</sup>	300	2 x 225
		kW <sup>(3)</sup>	225	2 x 166
 Maximum	Poids MAXI moteur	Kg	393	2 x 272
		Lbs	866	2 x 600

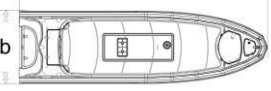
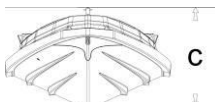
Dimensions coque (hors options)		
	a <sup>(4)</sup> (m)	7,78
	(ft)	25'6"
	b <sup>(4)</sup> (m)	2,27
	(ft)	7'5"
	(m)	1,37



	c <sup>(4)</sup> (ft)	4'5''
--	--------------------------	-------

## DESCRIPTION - Caractéristiques techniques

**Catégorie de conception :** Votre bateau est conçu pour naviguer en catégorie B ou C, cela implique des cas de charge différents et une implantation des accessoires différente. (cf tableau précédent).

Concernant la catégorie B le maximum de personnes autorisées est de 10 et l'aménagement du pont doit permettre à tous les passagers d'être assis et de pouvoir se tenir.

Pour cela, nous vous conseillons d'utiliser les accessoires T4 prévus à cet effet. (contacter votre revendeur)

### Position accessoires SIEGE T4 / BOLSTER T4. (suivant catégorie de conception)

Suivant la catégorie de navigation dans laquelle on veut utiliser le bateau, voici 2 emplacements de siège ou bolster répondant au nombre de place assise requise.

#### -Catégorie C.

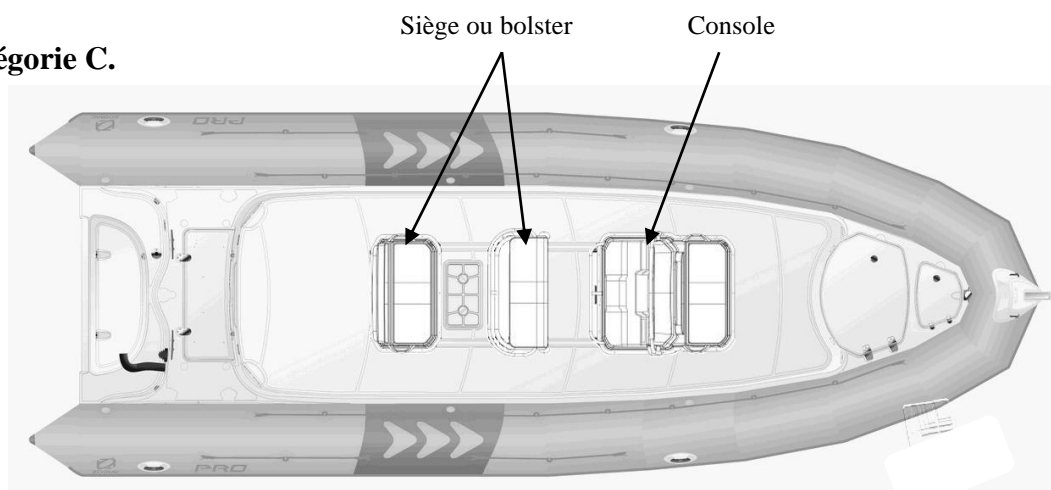

#### - Catégorie B.

- Le nombre de personne en catégorie B est limité à 10 toutes les personnes doivent être assises.

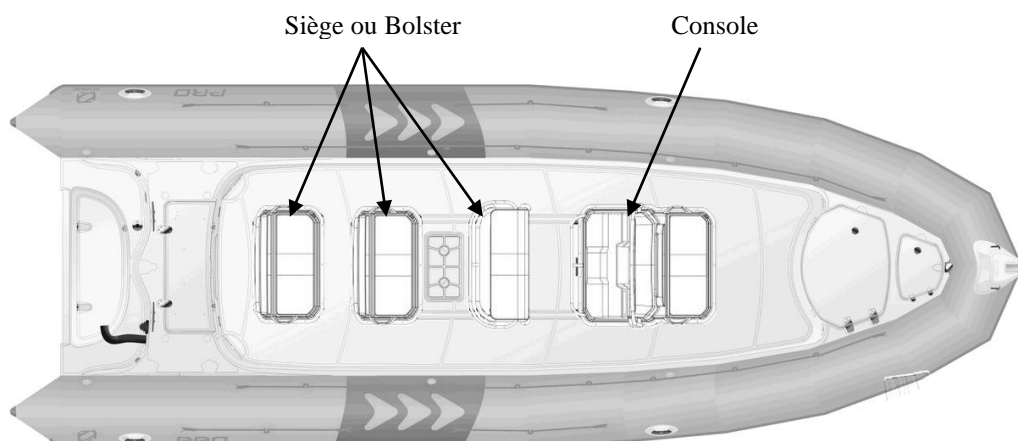

<b>NOTE</b>	<b>Tolérances sur les dimensions : +/- 4%</b> <b>Tolérances sur les poids : +/- 5%</b>
-------------	---

<b>NOTE</b>	<sup>(1)</sup> <b>La charge maximale autorisée a été calculée selon la norme ISO 6185. Il est recommandé de naviguer avec précaution lorsque le bateau est chargé au maximum.</b> <sup>(2)</sup> <b>Poids indiqués hors accessoires</b> <sup>(3)</sup> <b>Les puissances recommandées correspondent à une exploitation optimale des capacités du bateau pour une charge moyenne.</b> <sup>(4)</sup> <b>Dimensions de la coque sans flotteur.</b> <b>Utilisez la puissance maximale autorisée avec une extrême prudence (voir Tome 1 du manuel chapitre "Conseils de navigation").</b>
-------------	---

 <b>ATTENTION</b>	<b>LA CHARGE MAXIMUM INDIQUEE SUR LA PLAQUE CONSTRUCTEUR NE DOIT PAS ETRE DEPASSEE. LA CHARGE MAXIMUM COMPREND LA MASSE DU/DES MOTEUR(S), DU CARBURANT, DES ACCESSOIRES, DES PASSAGERS ET DE LEUR EQUIPEMENT ET TOUT AUTRE TYPE DE CHARGEMENT.</b>
---	--

 <b>ATTENTION</b>	<b>NE PAS STOCKER DE PRODUITS INFLAMMABLES DANS LE COMPARTIMENT ARRIERE. LE STOCKAGE D'UN RESERVOIR D'APPOINT EST FORMELLEMENT INTERDIT.</b>
---	--

## NETTOYAGE FLOTTEUR

Le flotteur de votre bateau est en tissu Hypalon™ Néoprène™ 1670 dtex .

Pour un entretien optimal, nous vous recommandons de nettoyer le flotteur à l'eau savonneuse ou avec des produits respectant l'environnement de type **Revival**, disponible chez votre revendeur.



**NE PAS UTILISER DE NETTOYANT AGGRESSIF A BASE DE  
SOLVANT COMME L'ACETATE**

## DESCRIPTIF TECHNIQUE

### I -2-INVENTAIRE

<b>COQUE</b>
• Coque polyester
• Pont contre moulé antidérapant
• 1 Anneau d'étrave
• 1 Baille à mouillage
• 1 chaumard
• 1 Bitte d'amarrage + 2 taquets arrières
• 1 Coffre avant + Bac amovible (75 litres)
• 1 coffre arrière.
• 2 Cadènes de traction
• 1 Nable de coque
• 4 Vide-vite gros débit
• 1 Réservoir 400 litres
• 1 Filtre séparateur eau/essence
• 1 Trappe accès vannes / jauge circuit essence
• 1 trappe accès raccordement tuyaux essence
• Circuit électrique avec coupleurs batteries et coupe circuit.
<b>FLOTTEUR</b>
• Flotteur amovible en Tissu STRONGAN DUOTEX 2 X 1100 décitex
• 7 Valves semi encastrées
• Bande antiragage à profil Ultra large
• 4 poignées extérieures
• 2 Patches
• saisines
• Cônes courts
• 1 Davier + Réa + feux / feu blanc arrière
<b>EQUIPEMENT STANDARD</b>
• 2 pagaies
• Gonfleur à pieds
• Bouchon manomètre
• Mallette de réparation
<b>ACCESSOIRES EN OPTION *</b>
• Console T4
• Siege T4
• Bolster
• Dossier arrière
• Mat de ski
• Roll-bar
• T Top
• Echelle de bain
• Racks à bouteille 4 et 6 bouteilles
• Gonfleur électrique.

\* Pour plus d'information sur les accessoires optionnels disponibles voir votre revendeur ZODIAC.

# DESCRIPTION - Eléments fonctionnels

## I-3-LOCALISATION DES ELEMENTS

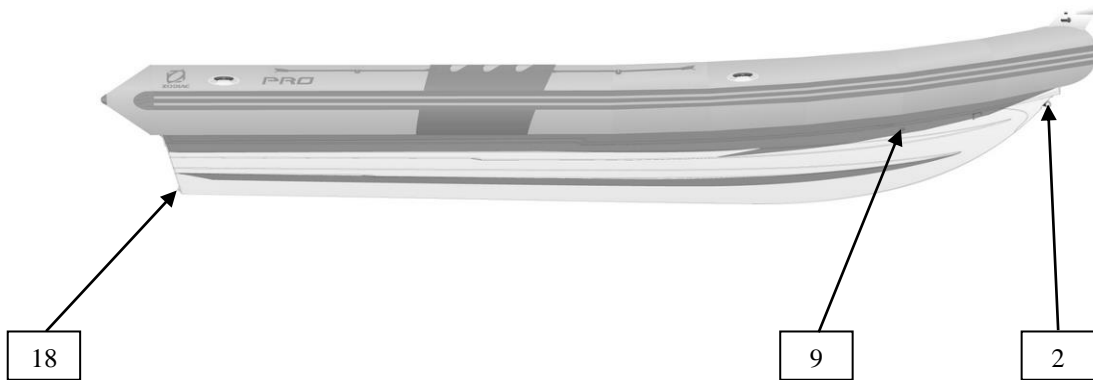
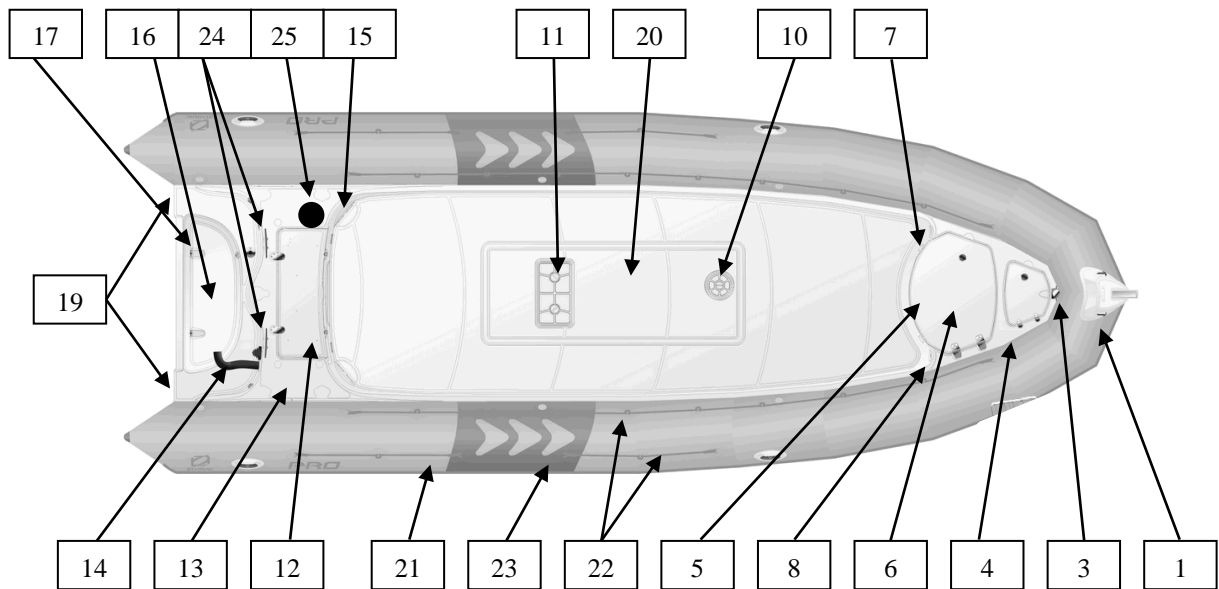

## DESCRIPTION - Eléments fonctionnels

REPERE	DESIGNATION
1	Davier avec Réa + taquet+ feux
2	Anneau d'étrave
3	bitte d'amarrage
4	Capot baille à mouillage
5	Remplissage essence
6	Bac amovible 75 litres
7	Grille de ventilation compartiment réservoir
8	Event réservoir
9	Evacuation trop plein d'essence
10	Trappe accès tuyau réservoir.
11	Trappe accès vanne / jauge réservoir
12	Capot arrière
13	Filtre séparateur eau/essence
14	Passage câbles moteur
15	Vide – vite gros débit
16	Auge arrière
17	Nables auge
18	Nable de coque
19	Cadènes arrières
20	Réservoir
21	Flotteur
22	saisine
23	Logos pro
24	Taquets arrières
25	Embasse feu blanc

# DESCRIPTION - Manutention

## I-4-MANUTENTION

### I-4-1-Transport:

- Les conseils de la mise sur remorque sont spécifiés dans le manuel du propriétaire TOME I.

### I-4-2-Stockage :

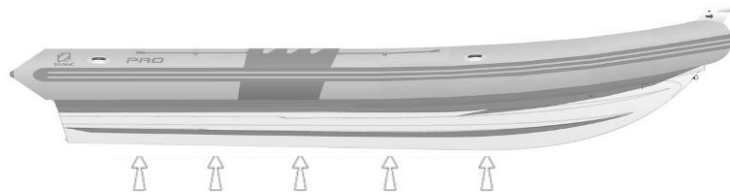

 <b>ATTENTION</b>	<p style="text-align: center;"><b>LE BATEAU DOIT IMPERATIVEMENT REPOSER SUR LA LIGNE D'ETRAVE (VOIR CROQUIS CI-DESSOUS).</b></p>
---	--



### I-4-3-Levage : Le bateau ne dispose pas de moyens de levage.

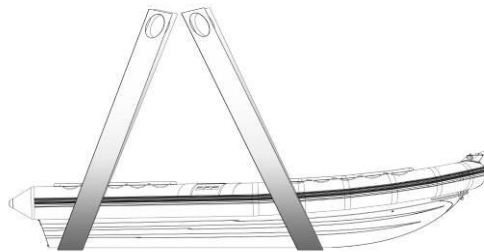

 <b>AVERTISSEMENT</b>	<p style="text-align: center;"><b>LE BATEAU NE DISPOSANT PAS DE MOYEN DE LEVAGE.</b>  <b>L'OPERATION DE LEVAGE DOIT OBLIGATOIREMENT S'EFFECTUER EN PASSANT DES SANGLES DE LEVAGE APPROPRIEES SOUS LA COQUE.</b>  <b>POUR CETTE OPERATION S'ADDRESSER A DES SPECIALISTES DU LEVAGE.</b>  <b>DEGONFLER LE FLOTTEUR POUR CETTE OPERATION.</b></p>
--	--



 <b>ATTENTION</b>	<p style="text-align: center;"><b>AUCUN PASSAGER A BORD LORS DU GRUTAGE</b></p>
 <b>AVERTISSEMENT</b>	<p style="text-align: center;"><b>LE BATEAU DOIT ETRE DECHARGE DE TOUT MATERIEL LORS DU GRUTAGE.</b></p> <p style="text-align: center;"><b>OUVRIR LE NABLE (18) AVANT LA MISE A L'EAU DU BATEAU AFIN D'ASSURER L'EVACUATION EVENTUELLE D'EAU DE PLUIE DANS LE COCKPIT (REFERMER LE NABLE AVANT LA MISE A L'EAU)</b></p>

# FLOTTEUR – Montage du flotteur sur la coque

## II -1- MONTAGE DU FLOTTEUR SUR LA COQUE

<b>NOTE:</b>	<b>Le montage du flotteur sur la coque s'effectue avec le flotteur dégonflé.</b>
	Vous pouvez effectuer un gonflage du flotteur non monté (pression 240 mb) et le laisser stabiliser environ une heure. Le dégonfler ensuite.
	Si le flotteur a été stocké à une température inférieure à 0°C, laissez le 12H dans un lieu tempéré (20°C) avant de le déplier.

1

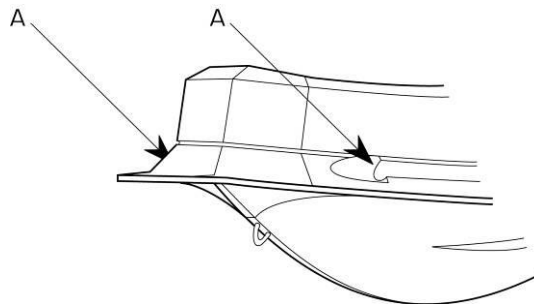

Pour faciliter la mise en place du flotteur, mettez du savon liquide (A) dans les rails de la coque

2

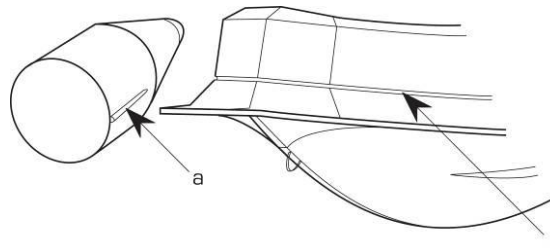

Positionnez la ralingue (a) du flotteur dans le rail de la coque (b) situé à l'avant de la coque. Tirez le flotteur jusqu'à amener la mini - ralingue en face du rail arrière.

3

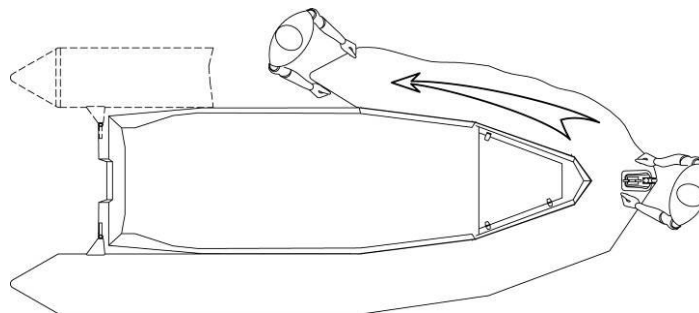

- Procéder de la même façon pour l'autre côté du flotteur.
- Avancer le nez du flotteur afin de rabattre la bavette extérieure sous le nez de la coque.
- Tirer de nouveau les 2 pattes du flotteur au maximum vers l'arrière du bateau en essayant de centrer le nez par rapport à l'avant de la coque.
- Gonfler légèrement le nez du flotteur pour vérifier qu'il soit bien centré et épouse parfaitement la coque. Recommencer l'opération si le flotteur n'est pas correctement positionné.



# FLOTTEUR – Fixation de la bavette

## II -2- FIXATION DE LA BAVETTE

4

Fixer la bavette externe à l'aide des barres inox et des boulons fournis dans le kit flotteur. Pour assurer l'étanchéité de l'ensemble, mettre du mastic d'étanchéité sur les vis et dans les trous de la coque.

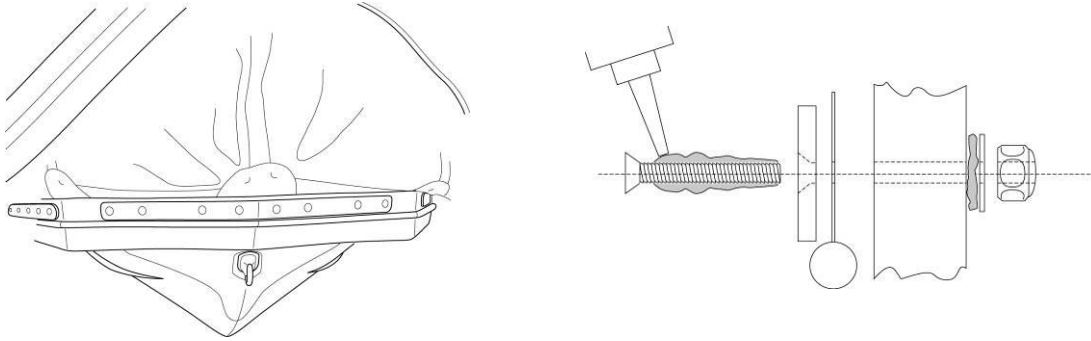

# FLOTTEUR – Système de gonflage

## II -3-SYSTEME DE GONFLAGE

### II -3-1- Le gonfleur

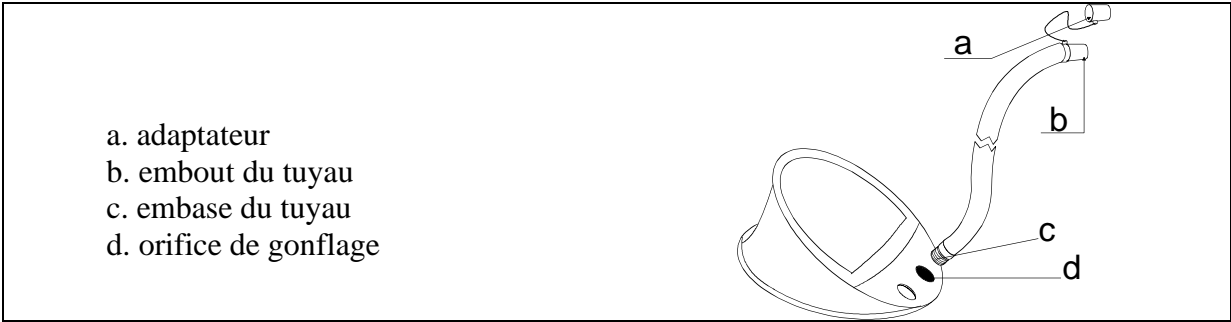

\* Un gonfleur électrique (12 V) gros débit est disponible en option. (contacter votre revendeur).

### II -3-2- Les valves "Easy - Push"

Pour changer de position	en position de gonflage	en position de dégonflage
 Poussez	 La membrane est fermée, le poussoir en position haute	 La membrane est ouverte, le poussoir en position basse

**NOTICE:** IL FAUT TOUJOURS REMETTRE LE BOUCHON DE LA VALVE APRES AVOIR EFFECTUE LE GONFLAGE OU LE DEGONFLAGE

## FLOTTEUR – Système de gonflage

### II -3-3- L'indicateur de pression (Vissez-le à la place du bouchon de valve)

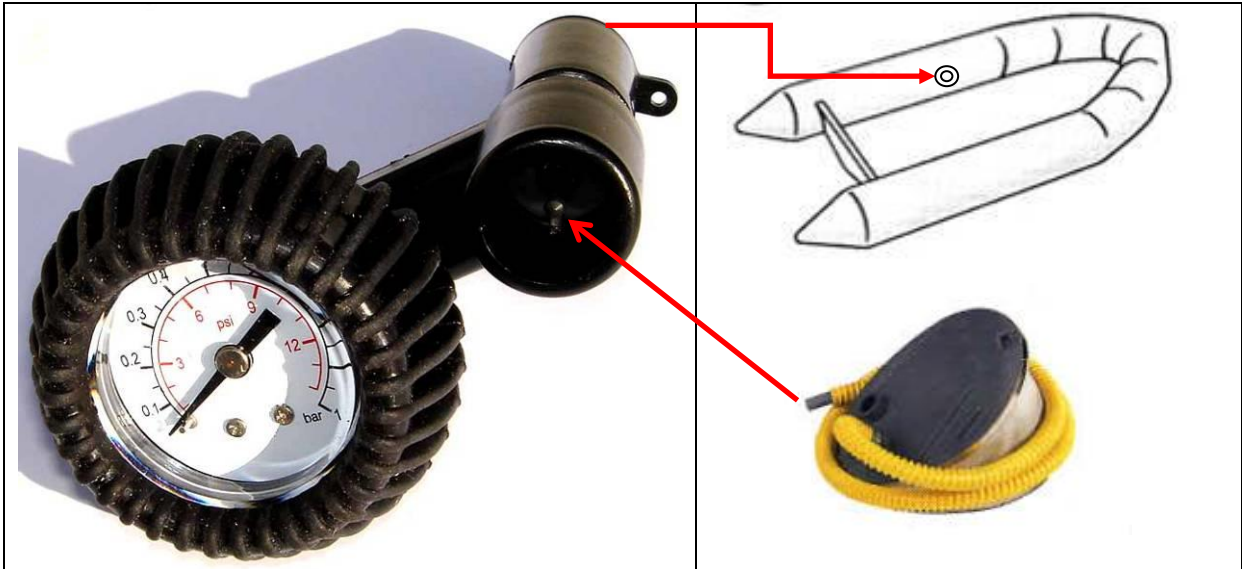

### II -3-4- Gonflage du flotteur

**Activez toutes les valves en position gonflage.**

Fixez l'embase du tuyau à l'orifice de gonflage du gonfleur.

Pour bien gonfler votre bateau, il faut que le gonfleur ait une bonne assise sur le sol.

Le bateau se gonfle rapidement si le gonfleur est actionné en souplesse et sans précipitation.

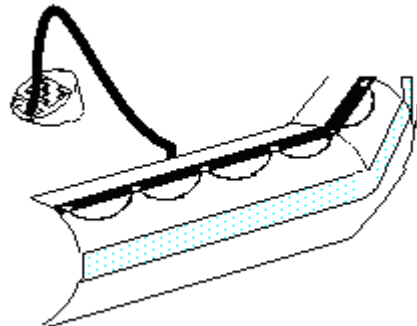

**NE PAS UTILISER DE COMPRESSEUR OU DE BOUTEILLE A AIR COMPRIE.**

# FLOTTEUR - Pression

## II -4-1- Gonflage du Flotteur

- Ajoutez l'adaptateur correspondant au diamètre de la valve semi encastrée à l'embout du tuyau du gonfleur.

Procédez au gonflage du flotteur **en équilibrant les pressions entre les différents compartiments, jusqu'à ce que les cloisons (a) ne soient plus visibles (pression = 240 mb)**

	<p>Ne jamais mettre un compartiment sous pression les autres étant complètement dégonflés</p>	
--	---	--

	1	
--	---	--

	2	
--	---	--

**Le gonflage est terminé:** Vissez les bouchons des valves de gonflement.

<b>NOTE :</b>	<p style="text-align: center;"><b>Il est normal de constater une légère fuite d'air avant le vissage du bouchon de valve. Seuls les bouchons assurent l'étanchéité finale.</b></p>
---------------	--

## II -4-2- Pression

**La pression d'utilisation pour le flotteur est de 240 mb/ 3,4 PSI** (milieu de la zone verte du manomètre).

Votre bateau est équipé d'un indicateur de pression **ACCESS** qui vous permettra une lecture rapide et efficace pendant le gonflage (voir explications d'utilisation section « Système de gonflage »).

La température ambiante de l'air ou de l'eau influe proportionnellement sur le niveau de la pression interne du flotteur:	Température ambiante	pression interne du flotteur
	+1°C	+4 mb / 0,06 PSI
	-1°C	-4 mb / 0,06 PSI

## FLOTTEUR - Pression

**Aussi, est-il important de savoir anticiper :**

**Vérifiez et ajustez la pression des compartiments gonflables (en regonflant ou en dégonflant selon le cas) en fonction des variations de température (surtout lorsque les écarts de température sont importants entre le matin et le soir dans les zones particulièrement chaudes) et assurez-vous que la pression ne s'écarte pas de la zone de pression recommandée (de 220 à 270 mb / zone verte).**

### RISQUE DE SOUS-PRESSION:

**EXEMPLE:** Votre bateau est exposé sur la plage en plein soleil (température=50°C) à la pression recommandée (240 mb/3,4 PSI). Lorsque vous le mettez à l'eau (température=20°C), la température et la pression interne des compartiments gonflables vont conjointement baisser (jusqu'à 120 mb) et **IL VOUS FAUDRA ALORS REGONFLER** jusqu'à regagner les millibars perdus à cause de l'écart de température entre l'air ambiant et l'eau. Ainsi il est normal de constater une diminution de pression en fin de journée lorsque la température extérieure baisse.

### RISQUE DE SURPRESSION:

**EXEMPLE:** Votre bateau est gonflé à sa pression recommandée (240 mb/3,4 PSI) en début ou fin de journée (température extérieure basse=10°C). Plus tard dans la journée, votre bateau est exposé en plein soleil sur la plage ou sur le pont d'un yacht (température=50°C). La température intérieure des compartiments gonflables peut alors s'élever et atteindre jusqu'à 70°C (flotteurs de couleur foncée notamment) entraînant un doublement de la pression de départ (480 mb). **IL VOUS FAUDRA ALORS DEGONFLER** afin de revenir à la pression recommandée.



**ATTENTION**

**SI VOTRE BATEAU EST TROP GONFLE, LA PRESSION SOLLICITE DE FAÇON ANORMALE LA STRUCTURE GONFLABLE POUVANT ENTRAÎNER UNE RUPTURE D'ASSEMBLAGE.**

### EN CAS DE SURPRESSION

**VALVE "Easy - Push":**  
Libérez de l'air en appuyant sur le poussoir de la valve

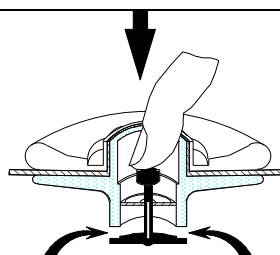

## SYSTEME DE PROPULSION

Conformez-vous aux recommandations ZODIAC et aux recommandations du constructeur de moteur pour le montage du /des moteurs.

Pour une utilisation optimale de votre embarcation, veuillez consulter votre concessionnaire.

# INSTALLATION ET CIRCUIT – Carburant

## IV -1-CARBURANT

### IV -1-1-Description des éléments fonctionnels essentiels :

Le bateau est équipé d'un réservoir, situé sous le pont. Son remplissage s'effectue par l'avant du bateau par un orifice de remplissage situé sous le capot avant.

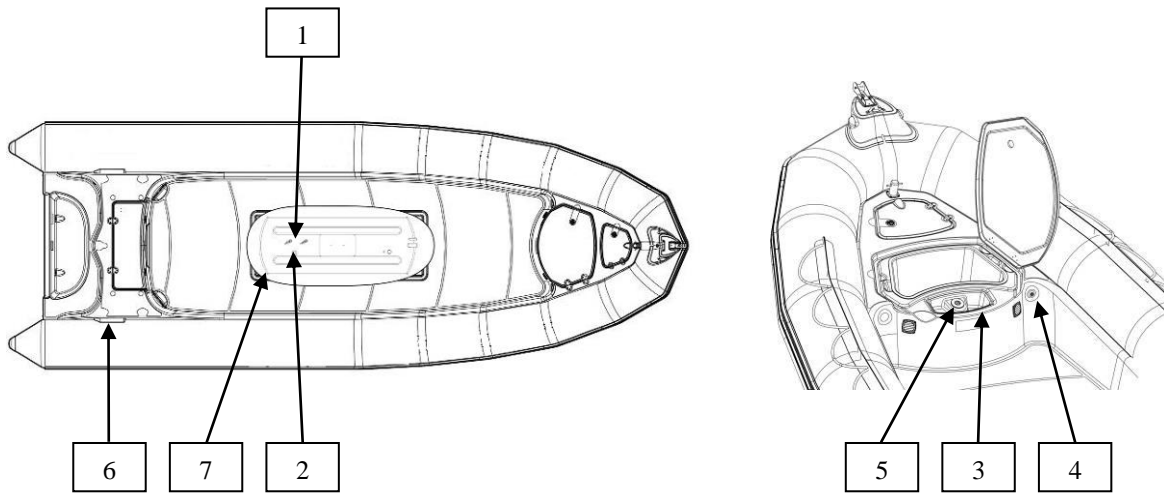

REPERE	DESIGNATION
1	Vanne de fermeture essence
2	Transmetteur de jauge
3	Nable de vidange du compartiment de « trop plein »
4	Event
5	Orifice de remplissage
6	Filtre séparateur eau/essence (fourni pour montage mono moteur)
7	Réservoir d'essence

 <b>AVERTISSEMENT</b>	<p><input checked="" type="checkbox"/> <b>DANS LE CAS D'UNE UTILISATION MONO MOTEUR NE PAS OUBLIER DE FERMER LA VANNE ESSENCE DU DEUXIEME MOTEUR.</b></p>
---	---

### IV-1-2-Réservoir

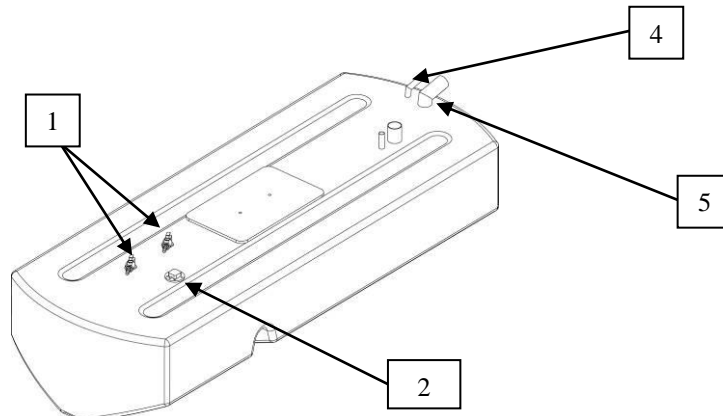

# INSTALLATION ET CIRCUIT – Carburant

## IV-1-3-Filtre séparateur eau/essence

<b>NOTE :</b>	<b>Afin de protéger le moteur, un filtre séparateur d'eau /essence est placé sur le circuit d'alimentation essence du moteur.</b>
---------------	---

Le filtre séparateur eau/essence se situe dans le coffre arrière, sur la paroi tribord : (pour un montage bi moteur contacter votre revendeur pour vous procurer un deuxième filtre)



REPERE	DESIGNATION
<b>1</b>	<b>Tête du filtre, fixée au bateau</b>
<b>2</b>	<b>Élément de filtration interchangeable</b>

<p style="background-color: yellow; font-weight: bold; margin-top: 5px;">AVERTISSEMENT</p>	<p style="background-color: yellow; font-weight: bold;">IL EST INDISPENSABLE DE REMPLACER LA CARTOUCHE TOUTES LES 50 HEURES D'UTILISATION. CONTACTER LE RESEAU POUR L'ACHAT D'UNE CARTOUCHE DE REMPLACEMENT.</p>
--	--



# INSTALLATION ET CIRCUIT – Carburant

## Changement de la cartouche du filtre :

Conformez-vous aux recommandations ZODIAC et aux recommandations du constructeur du filtre.

Placer un entonnoir de vidange sous l'endroit où la cartouche sera remplacée.

Avant d'effectuer le remplacement du filtre la pression du système d'alimentation d'essence doit être libérée.

Suivre le manuel ou les instructions du fabricant du moteur.

L'essence est une matière extrêmement inflammable. **COUPEZ LE MOTEUR**, déconnectez la batterie et ne pas fumer ni procéder à l'installation du kit à proximité d'une flamme nue

Placez un entonnoir de vidange sous l'endroit où la cartouche sera remplacée

Avant d'effectuer le remplacement du filtre la pression du système d'alimentation d'essence doit être libérée.



## IV-1-4- Utilisation des vannes de fermeture circuit essence :

<b>NOTE :</b>	<ul style="list-style-type: none"><li>- Lorsque vous n'utilisez plus votre bateau, fermez la vanne du circuit essence.</li><li>- Lorsque vous allez utiliser votre bateau, ouvrez la vanne du circuit essence.</li></ul>
---------------	--

Vanne du circuit essence  
Position ouverte

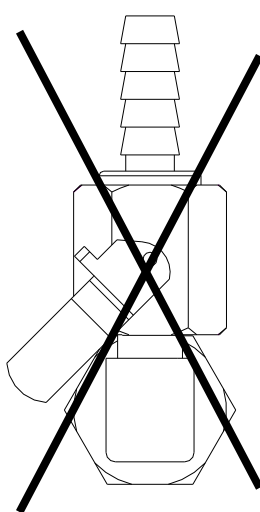
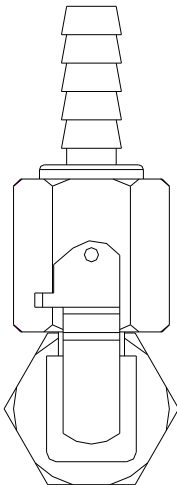



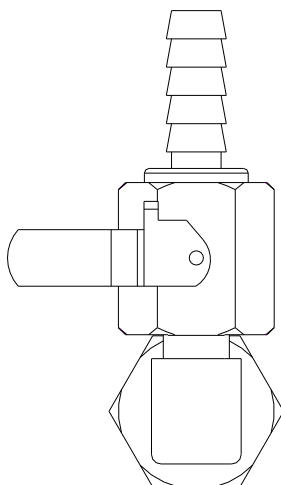

Vanne du circuit essence  
Position fermée



## INSTALLATION ET CIRCUIT – Carburant

### IV-1-5-Recommandations :

 <b>AVERTISSEMENT</b>	<p><b>EN CAS DE FUITE D'ESSENCE, OU D'INCENDIE, LA VANNE DE FERMETURE DU CIRCUIT ESSENCE, SITUEE SUR LE RESERVOIR, PERMET D'ISOLER LE RESERVOIR DU CIRCUIT ESSENCE ET DOIT RESTER FERMEE.</b></p>
 <b>AVERTISSEMENT</b>	<ul style="list-style-type: none"> <li><input checked="" type="checkbox"/> <b>UN RESERVOIR PLEIN EVITE LA CONDENSATION A CHAQUE SORTIE.</b></li> <li><input checked="" type="checkbox"/> <b>FAITES NETTOYER LE RESERVOIR TOUS LES 5 ANS.</b></li> <li><input checked="" type="checkbox"/> <b>VERIFIEZ LE SERRAGE DES COLLIERS SUR TOUTES LES DURITS.</b></li> <li><input checked="" type="checkbox"/> <b>LORSQUE VOUS PURGEZ LE FILTRE, NE VIDEZ PAS L'EAU DANS LE BATEAU. UTILISEZ UN BAC DE RECUPERATION SOUS LE FILTRE.</b></li> <li><input checked="" type="checkbox"/> <b>COUPEZ LE CONTACT AVANT DE DEMONTER LA CARTOUCHE DU FILTRE.</b></li> <li><input checked="" type="checkbox"/> <b>LIRE ATTENTIVEMENT LES INSTRUCTIONS SUR LA NOTICE DU FILTRE.</b></li> </ul>
 <b>AVERTISSEMENT</b>	<ul style="list-style-type: none"> <li><input checked="" type="checkbox"/> <b>L'ESSENCE EST EXTREMEMENT INFLAMMABLE. LORSQUE VOUS DEVEZ INTERVENIR SUR LE SYSTEME DE CARBURATION, ASSUREZ VOUS QUE LES MOTEURS SOIENT ARRETES.</b></li> </ul> <p><b>NE PAS FUMER ; ELOIGNER TOUTE FLAMME OU CORPS INCANDESCENT DE LA ZONE DE TRAVAIL.</b></p>
 <b>AVERTISSEMENT</b>	<ul style="list-style-type: none"> <li><input checked="" type="checkbox"/> <b>NE JAMAIS PERCER DANS LA ZONE RESERVOIR AVEC UN FORET DEPASSANT DE PLUS DE 30 MM DU MANDRIN DE LA PERCEUSE (REPERE SUR LE PONT PAR LA TRAPPE) ET NE PAS UTILISER DES VIS DE PLUS DE 20 MM DE LONGUEUR.</b></li> </ul>

# INSTALLATION ET CIRCUIT – Electricité

## IV -2-Electricité

IV -2-1-Schéma de principe : (un plan format A3 est fourni avec le boîtier de connexion console).

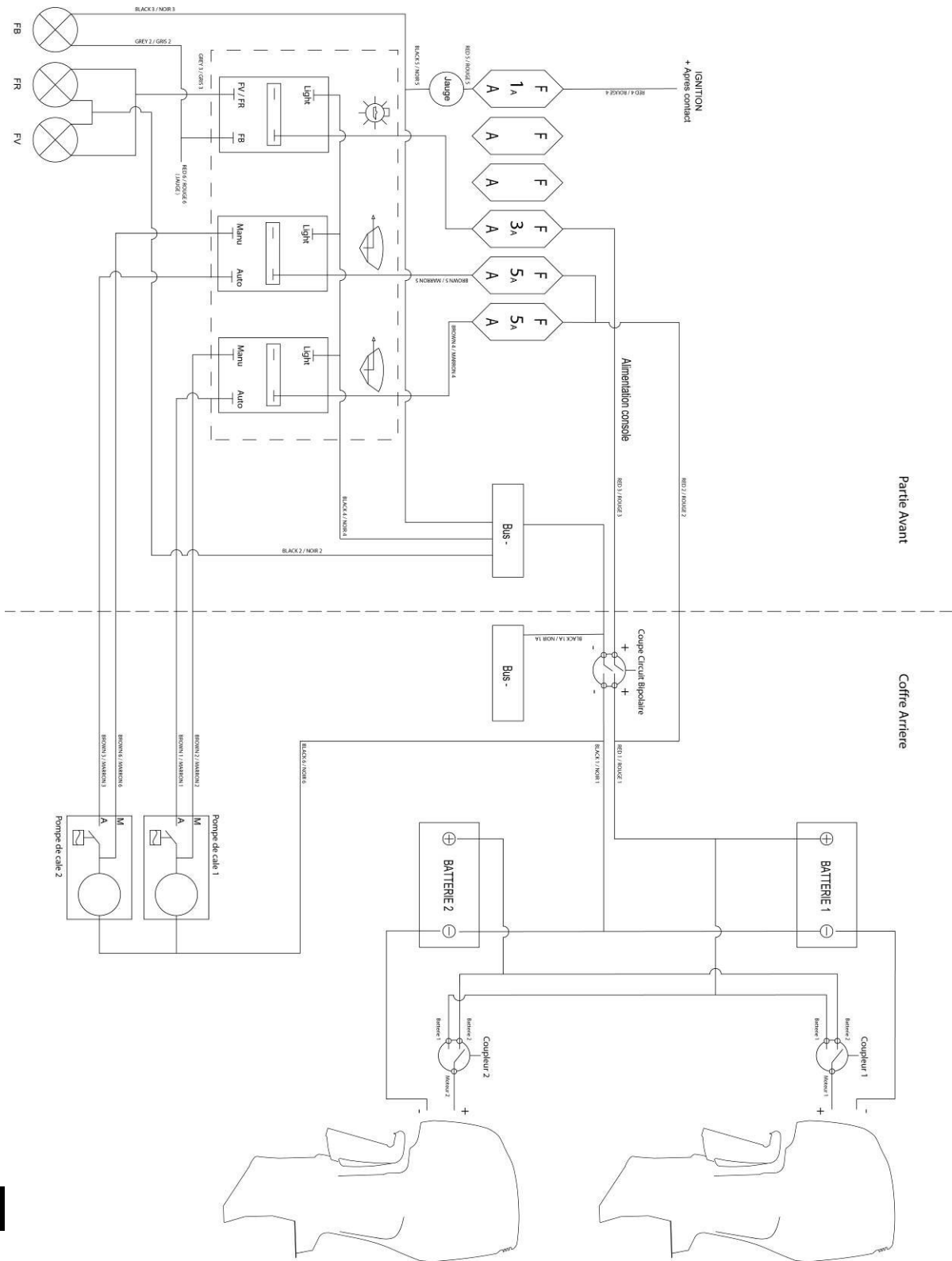



### IV-2-3 Localisation des éléments.

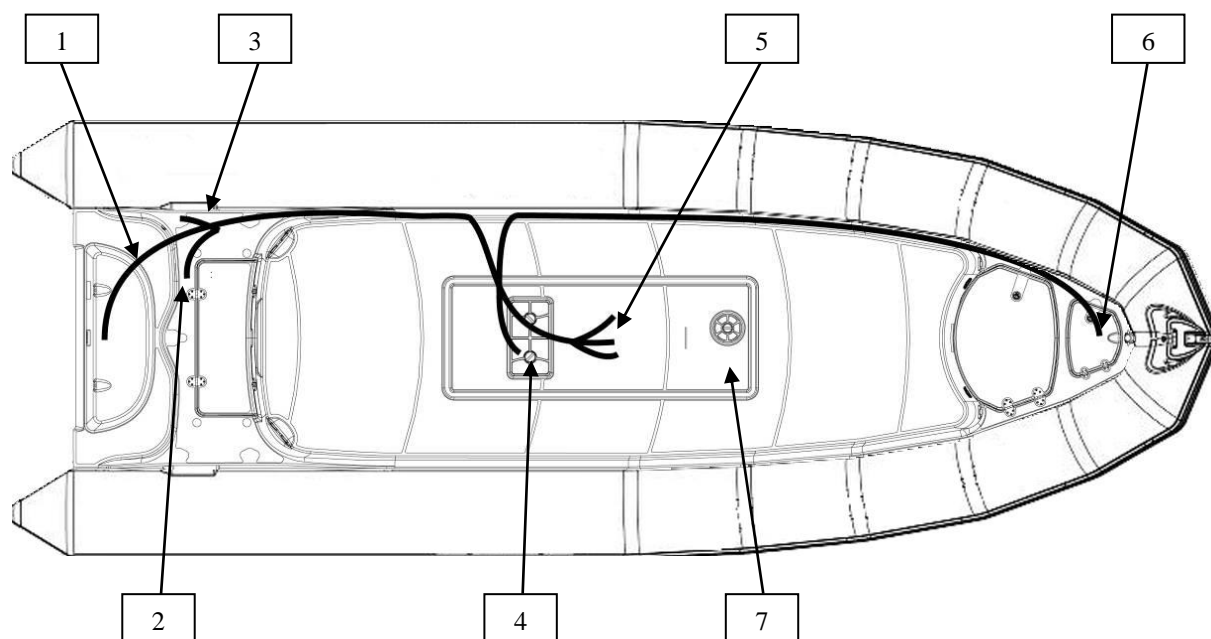

Correspondance :

N° REPERE	DESIGNATION
1	Alimentation pompe de cale
2	Support coupleurs et coupe batterie
3	Alimentation en attente pour feu blanc de navigation
4	Jauge réservoir
5	Câble en attente sous la trappe pour câblage dans la console
6	Alimentation feux de navigation vert / rouge
7	Position du passe câbles

### IV-2-4-Câblage du boîtier et interrupteur console.

Votre bateau est pré équipé d'un faisceau électrique, il reste à connecter certains éléments sur la console à savoir :( Le reste du faisceau à connecter dans la console se situe sous le pont repère 5)

- 1 Boîtier : répartiteur (bus bar + porte fusible)

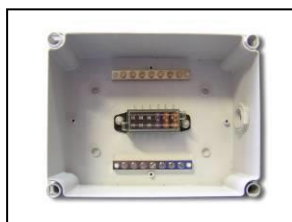

## INSTALLATION ET CIRCUIT – Electricité

- Les interrupteurs de commande des feux + pompes de cale (livrés également).

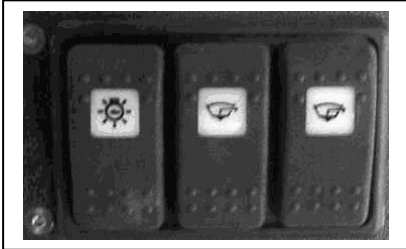

- Le récepteur de jauge essence.

### IV-2-5 Préparation au câblage.

#### IV-2-5-1 : Montage du passe câble. (Livré).

 <b>AVERTISSEMENT</b>	<b>LORS DE L'OPERATION DE PERÇAGE FAITES ATTENTION AU RESERVOIR SITUE JUSTE EN DESSOUS.</b>
---	---

1-Percer le trou pour le passage des câbles (zone grisée)

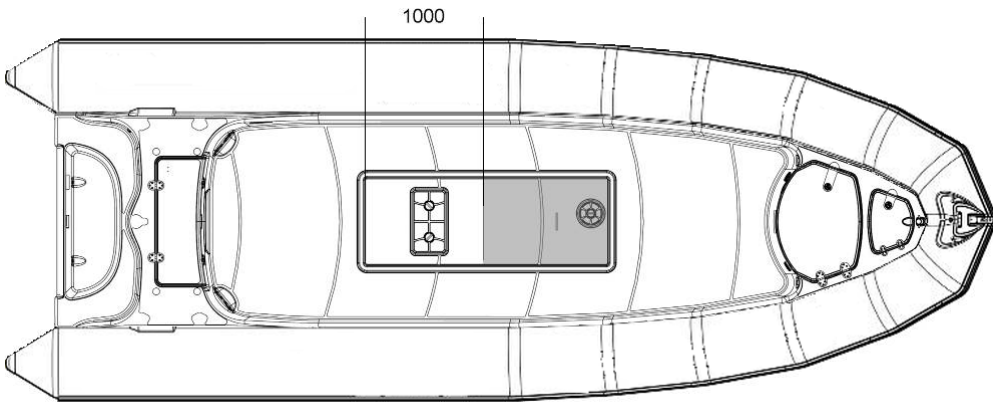

2- Récupérer les câbles électriques du faisceau en attente. Repère 5

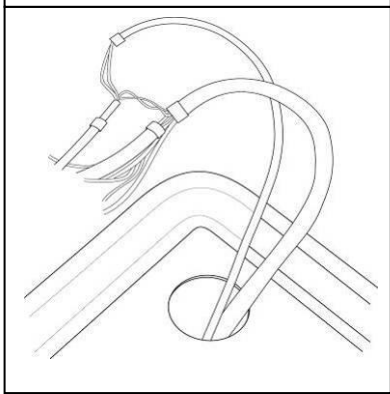

3- Présenter la bride pour pré-percer le pont, puis percer.

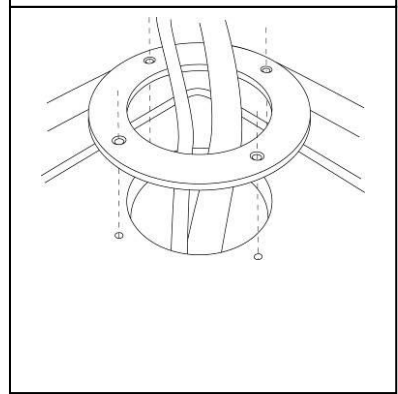

4 -Passer le passe câble, la bride puis fixer le tout sur le pont. (Bien étancher les vis, et le dessous du passe câbles)

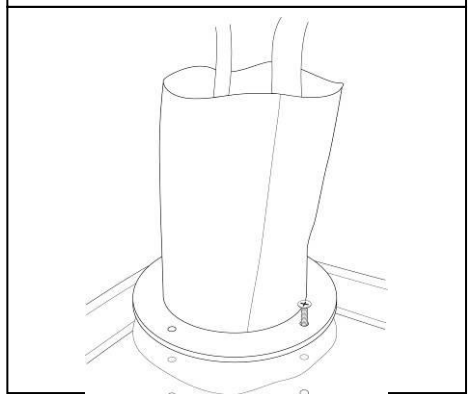

# INSTALLATION ET CIRCUIT – Electricité

## IV-2-5-2 : Câblage du boîtier :

Après avoir positionner la console sur le pont, et fait passer les câbles à travers l'étagère de console (si console T4) procéder au câblage du boîtier.

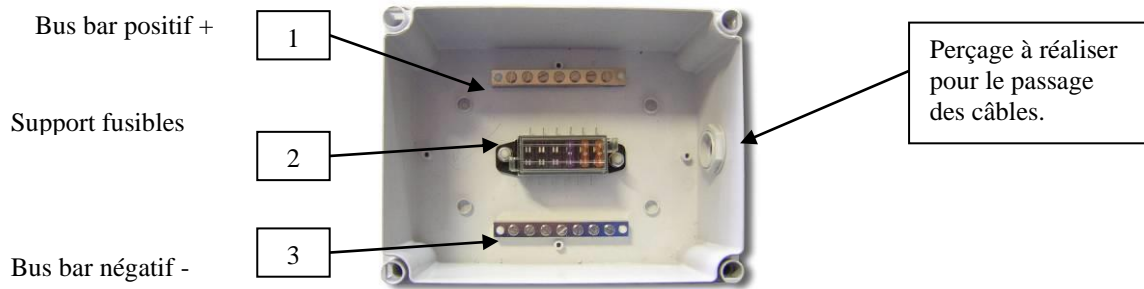

## IV-2-5-3 : Câblage

- Etape 1 : Connecter les câbles suivant sur le bus support fusible (repère 2).

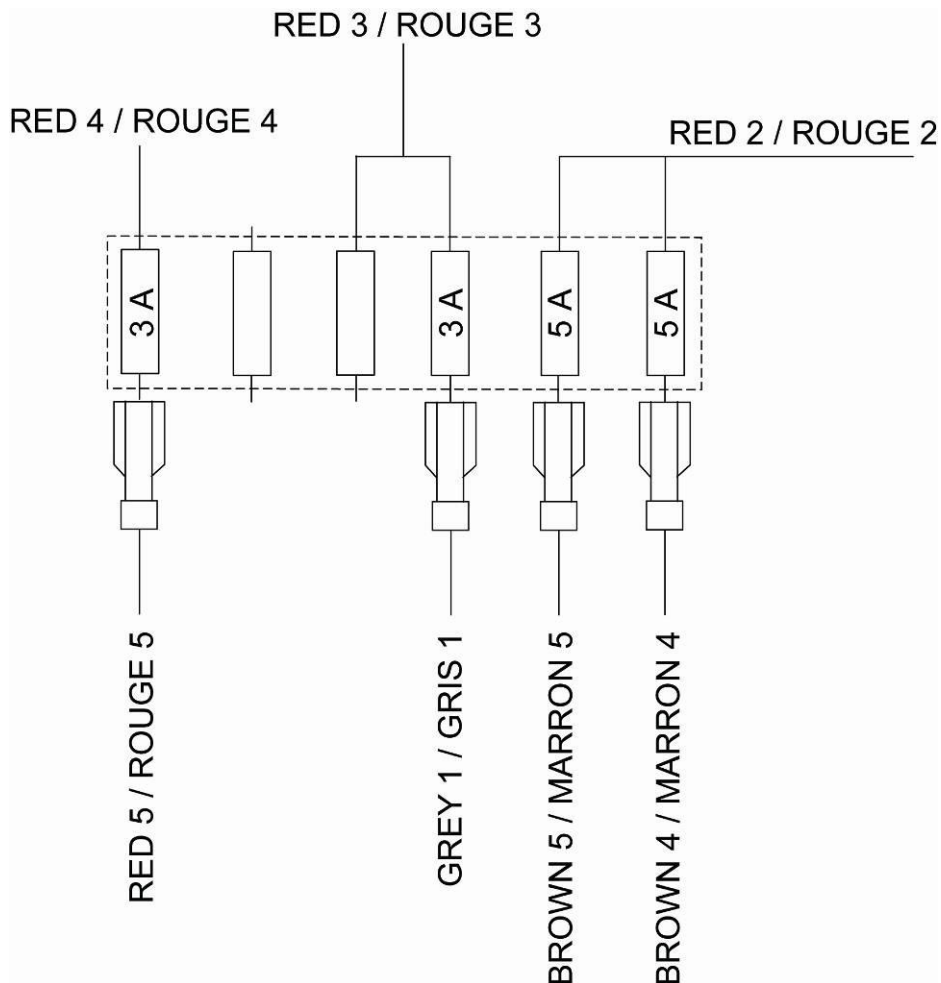

# INSTALLATION ET CIRCUIT – Electricité

- Etape 2 : Connecter les câbles suivant sur le bus bar négatif (repère 3).

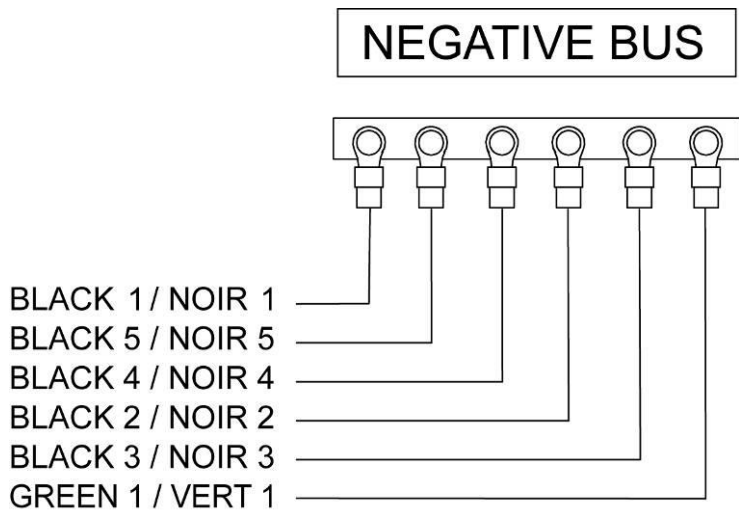

- Etape 3 : Connecter les câbles suivant sur le bus bar positif (repère 1).

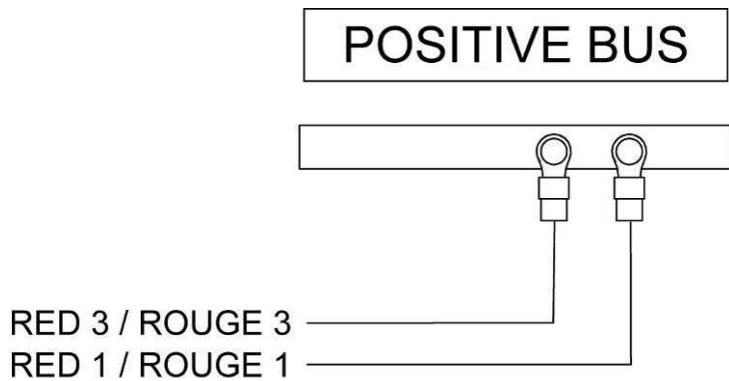

- Etape 4 : Fixer le boîtier sur la console.

Avant de fixer le boîtier sur le flanc de la console, coller une plaque de contre plaqué afin de créer de l'épaisseur pour effectuer le vissage.

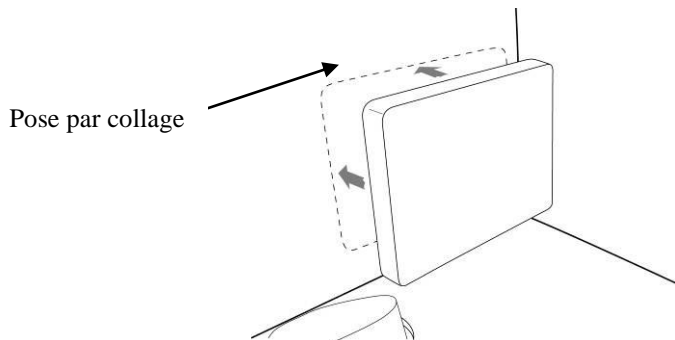



## INSTALLATION ET CIRCUIT – Electricité

Fixer le boîtier sur la plaque à l'aide de vis à bois (non fournies)

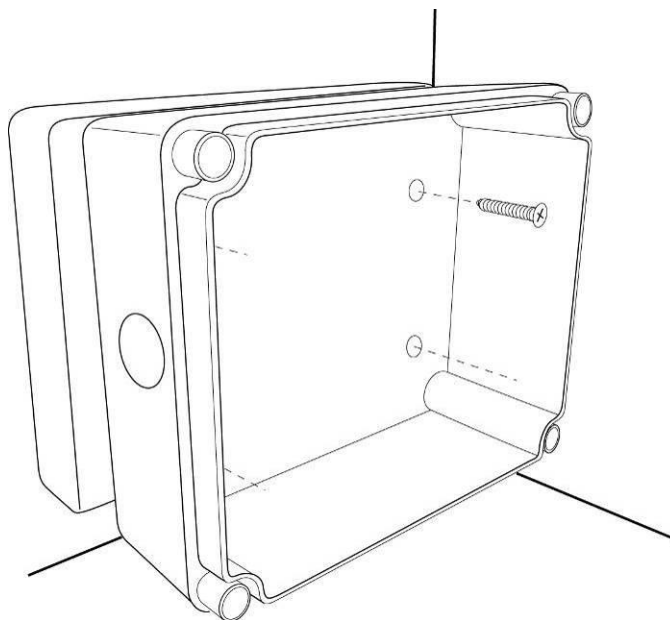

### IV-2-5-4 : Câblage des interrupteurs.(pompes de cale + feux)

- Etape 1 : Positionner les interrupteurs sur votre console ( en tenant compte de la longueur du faisceau électrique) .

Si vous équipez votre bateau d'une console T4, nous vous conseillons de positionner le panel d'interrupteurs comme indiqué ci-dessous.

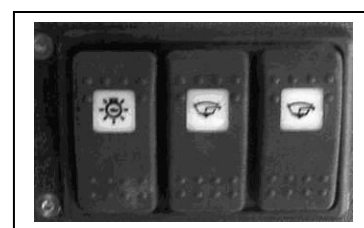
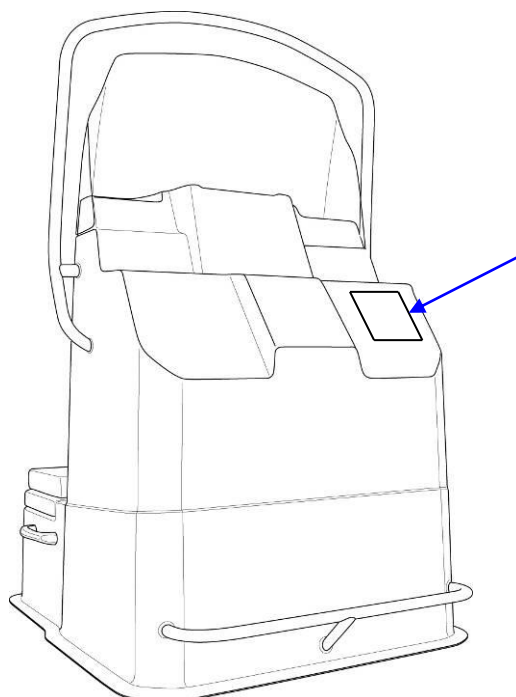

Emplacement conseillé pour le panel d'interrupteurs

# INSTALLATION ET CIRCUIT – Electricité

- Etape 2 : Câblage.

Groupe de fil à connecter

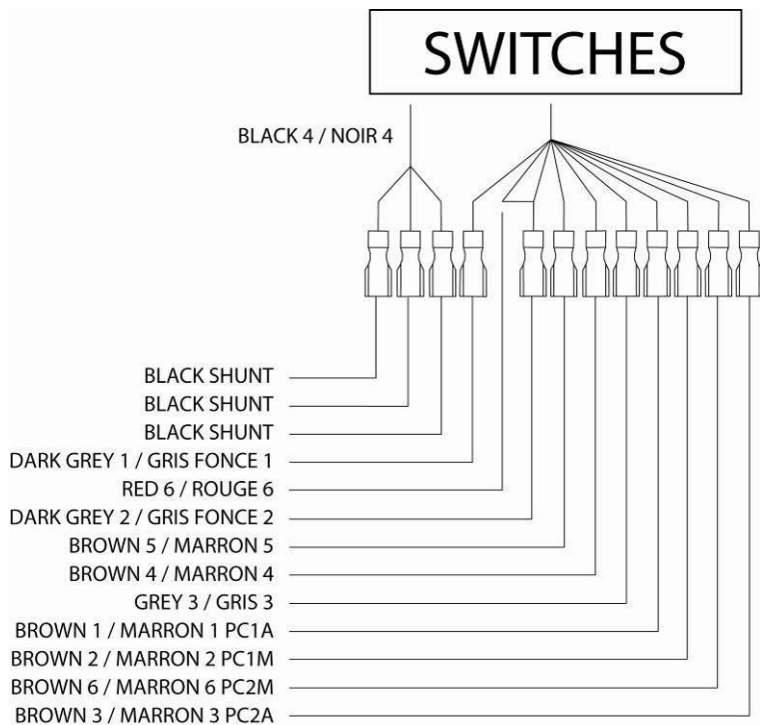

Câblage vu face arrière des interrupteurs.

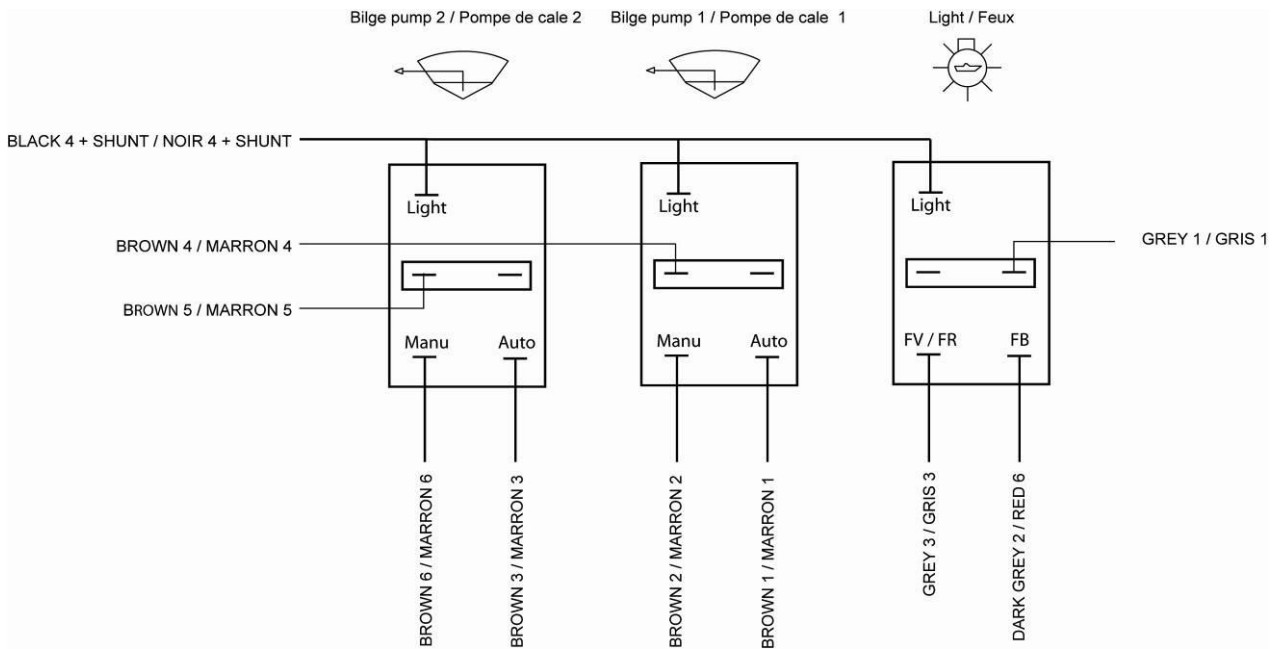

# INSTALLATION ET CIRCUIT – Electricité

IV-2-5-5 : Câblage du récepteur de jauge essence. (Vue arrière).

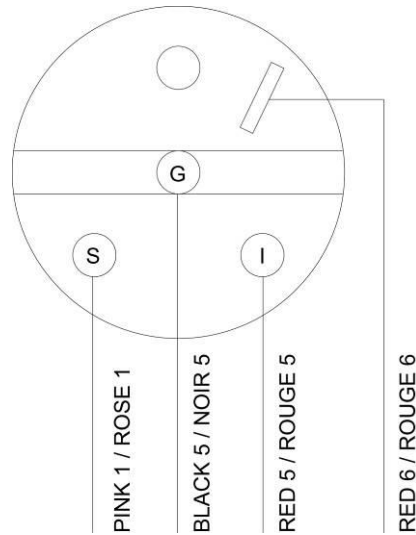

IV-2-5-6 :- Fonctionnement coupe circuit & coupleurs de batterie.

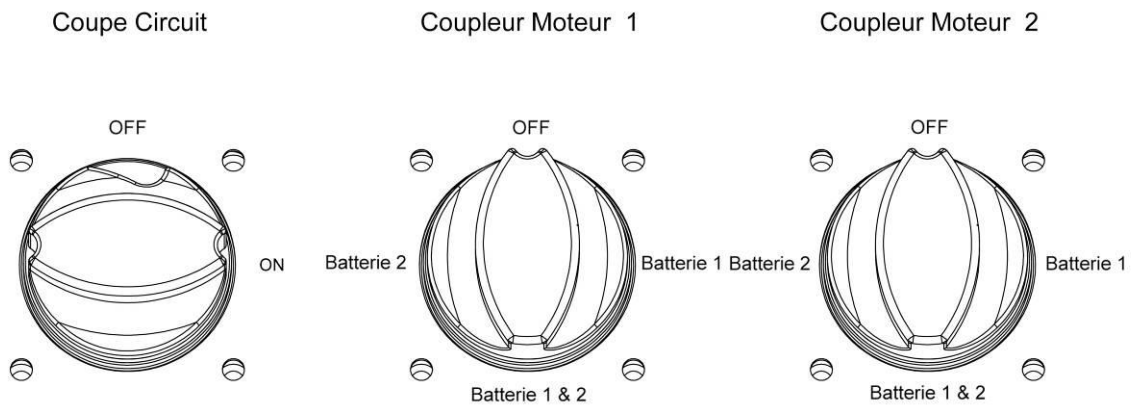

Votre bateau est équipé en série d'un coupe-circuit et de deux coupleurs de batteries (pour montage bi moteur).

Dans le cas d'un montage mono moteur, un seul coupleur sera utilisé.

## INSTALLATION ET CIRCUIT

Le coupe circuit, permet d'isoler l'alimentation du boîtier console.

<b>NOTE :</b>	Après chaque utilisation, pensez à mettre le coupe circuit sur position OFF.
---------------	--

Les coupleurs de batteries, permettent de démarrer les moteurs soit avec une batterie par moteur, soit en couplant les batteries (parallèles), ou bien de les démarrer avec une seule batterie.

IV-2-5-7 : Tableau des différentes configurations possibles.

ETAT COUPLEURS		RESULTAT
COUPLEUR 1 SUR POSITION "OFF"	COUPLEUR 2 SUR POSITION "OFF"	<b>LES MOTEURS ET LES BATTERIES SONT ISOLEES</b>
COUPLEUR 1 SUR POSITION "BAT 1"	COUPLEUR 2 SUR POSITION "BAT 2"	<b>CHAQUE MOTEUR DEMARRE AVEC SA BATTERIE RESPECTIVE. TOUJOURS METTRE LES COUPLEURS DANS CETTE CONFIGURATION</b>
COUPLEUR 1 SUR POSITION "BAT 1"	COUPLEUR 2 SUR POSITION "BAT 1"	<b>LES 2 MOTEURS DEMARRENT AVEC LA BATTERIE 1 (dans le cas ou la batterie 2 est défailante)</b>
COUPLEUR 1 SUR POSITION "BAT 2"	COUPLEUR 2 SUR POSITION "BAT 2"	<b>LES 2 MOTEURS DEMARRENT AVEC LA BATTERIE 2 (dans le cas ou la batterie 1 est défailante)</b>
COUPLEUR 1 SUR POSITION "BOTH"	COUPLEUR 2 SUR POSITION "BOTH"	<b>LES 2 MOTEURS SONT DEMARRES EN COUPLANT LES 2 BATTERIES</b>

# INSTALLATION ET CIRCUIT – Branchement d'options

## IV -2-6-BRANCHEMENT D'OPTIONS

### IV -2-6-1-Précautions :

Le bateau est équipé en série de 2 pompes de cale, des feux de navigation. Cependant, 2 emplacements restent disponibles sur le boîtier à fusibles (sous la console) pour le branchement d'accessoires supplémentaires sous certaines conditions :

① Les accessoires que voulez rajouter devront être branchés au niveau de la console.

② Les accessoires se partagent deux catégories :

**A** → les accessoires qui sont utilisés ou qui sont susceptibles d'être utilisés en continu lors d'une utilisation normale du bateau,

**B** → les accessoires qui sont utilisés de façon intermittente.

<b>A</b>	
Ventilateur de cale	
Radio	
Sondeur	
GPS	
Projecteur	
Système d'alarme	
Réfrigérateur	
VHF	
$\Sigma$	180W maxi

et

<b>B</b>	
Prise allume cigare	
Eclairage divers	
Avertisseur sonore	
Equipement électronique divers	
Pompe de douche	
<b>Puissance maxi retenue</b>	60W maxi

 <b>AVERTISSEMENT</b>	<p><b>Vous devez impérativement vous assurer que la somme des puissances des accessoires de la colonne A que vous <u>rajoutez</u> est inférieure ou égale à 180W (15A) <u>ET</u> que la puissance maxi d'un accessoire de la colonne B est inférieure ou égale à 60W (5A). Les sections des différents câbles du faisceau ont été calculées avec ces valeurs ; le non-respect de cette règle peut engendrer des dysfonctionnements électriques et causer des courts-circuits.</b></p>
---	---

Vous pouvez connecter les options directement sur le bus bar positif et négatif de la console (dans la limite de puissance maxi), en insérant un porte fusible homologué.

## INSTALLATION ET CIRCUIT – Branchement d’options

### Exemple 1

Vous voulez rajouter :  
 Une VHF de 72W,  
 Un GPS de 36W,  
 Une radio de 60W,  
 Un allume cigare de 72W,  
 Une montre de 20W.

A	
Ventilateur de cale	
Radio	60W
Sondeur	
GPS	36W
Projecteur	
Système d’alarme	
Réfrigérateur	
VHF	72W
Σ	168W (<180W ) ☺

et

B	
Eclairage divers	
Equipement électronique divers	20W (montre)
Pompe de douche	
Puissance maxi retenue	60W (< ou = 60W) ☺

CONCLUSION	☺
------------	---

### Exemple 2

Vous voulez rajouter :  
 Une VHF de 60W,  
 Un GPS de 36W,  
 Une radio de 48W,  
 Un projecteur de 120W.

A	
Ventilateur de cale	
Radio	48W
Sondeur	
GPS	36W
Projecteur	120W
Système d’alarme	
Réfrigérateur	
VHF	60W
Σ	264W (> 180W) ☹

et

B	
Eclairage divers	
Equipement électronique divers	
Pompe de douche	
Puissance maxi retenue	0 (< 60W) ☹

CONCLUSION	☹
------------	---

## INSTALLATION ET CIRCUIT – Branchement d’options

### Exemple 3

Vous voulez rajouter :  
 Un GPS de 60W,  
 Une radio de 60W,  
 Un avertisseur sonore de 120W.

A	
Ventilateur de cale	
Radio	60W
Sondeur	
GPS	60W
Projecteur	
Système d’alarme	
Réfrigérateur	
VHF	
Σ	120W (< 180W) ☺

et

B	
Eclairage divers	
Equipement électronique divers	
Pompe de douche	
Puissance maxi retenue	120W (> 60W) ☹

CONCLUSION	☹
------------	---

<b>NOTE :</b>	<b>Certains fabricants vous donneront l’ampérage au lieu de la puissance absorbée. En courant continu (c’est le cas ici), il suffit de multiplier par 12 pour obtenir la puissance et de diviser la puissance par 12 pour obtenir l’intensité consommée par l’appareil.</b>
---------------	---

### IV -2-6-2-Cablage :

- ① Choisir un emplacement de fusible libre,
- ② Connecter le câble d’alimentation de votre accessoire sur la borne correspondante à cet emplacement avec une «cosse languette» femelle de 6mm,
- ③ Si vous devez rajouter du câble pour le branchement, utiliser du câble de section mini 1.5mm<sup>2</sup> et respectant les recommandations en matière de câble « marine » (UL1426 ou SAE J378 ou SAE J1127 ou SAE J1128 ou d’une manière générale répondant aux recommandation ABYC et/ou CE),
- ④ Connecter le câble de masse de votre accessoire sur le bornier de masse avec une «cosse à œil» Ø5 (même remarque que précédemment pour le câble),
- ⑤ Insérer un fusible de type ATO d’intensité maxi de 15A et supérieure à l’intensité d’utilisation de votre appareil.

## INSTALLATION ET CIRCUIT – Branchement d’options

### IV -2-7-FONCTIONNEMENT DE LA POMPE DE CALE

Le fonctionnement de la pompe de cale est indépendant de la position du coupe-batterie ; l’interrupteur de commande  est toujours sous tension.

- ① Marche automatique (position fixe) ; dans cette position, le fonctionnement de la pompe de cale est automatique. Le voyant est allumé.
- ② Arrêt ; dans cette position (position fixe), la pompe de cale est arrêtée. Le voyant est éteint.
- ③ Marche forcée ; il faut maintenir l’interrupteur appuyé pour obtenir un fonctionnement en marche forcée. Dès que vous relâchez le doigt, l’interrupteur revient en position arrêt (2).

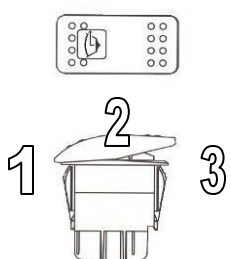

 <b>CONSEIL</b>	<b>AU MOUILLAGE, METTRE L’INTERRUPTEUR DE POMPE DE CALE SUR LA POSITION MARCHÉ AUTOMATIQUE.</b>
--	---

<b>NOTE :</b>	<b>ZODIAC RECOMMANDE L’USAGE D’UNE BACHE OU D’UN TAUX DE MOUILLAGE AFIN DE PREVENIR LES ENTRES D’EAU EN CAS DE PLUIE.</b>
---------------	---





## INSTALLATION ET CIRCUIT - Electricité

### IV -2-8-Batterie (non fournie)

Conformez vous aux recommandations ZODIAC et aux recommandations du fabricant de batteries pour l'entretien courant.

	<p>Entretenez votre batterie:</p> <ul style="list-style-type: none"> <li><input checked="" type="checkbox"/> Maintenez la batterie propre et sèche afin d'éviter une usure prématurée.</li> <li><input checked="" type="checkbox"/> Resserrez et entretenez les cosses sur borne en les graissant régulièrement avec de la vaseline.</li> </ul>
---	---

 <b>ATTENTION</b>	<p><b>L'EAU PROVENANT DU SYSTEME D'ADDUCTION D'EAU CONTIENT DES MINERAUX QUI ENDOMMAGENT LES BATTERIES. FAITES DONC TOUJOURS L'APPOINT AVEC DE L'EAU DISTILLEE</b></p>
 <b>AVERTISSEMENT</b>	<ul style="list-style-type: none"> <li>• <b>MAINTENIR LES BATTERIES ET L'ELECTROLYTE HORS DE PORTEE DES ENFANTS</b></li> <li>• <b>NE COUCHEZ JAMAIS LA BATTERIE.</b></li> <li>• <b>LORSQUE VOUS RAJOUTEZ DE L'ELECTROLYTE OU QUE VOUS RECHARGEZ LA BATTERIE, RETIREZ-LA TOUJOURS DU COMPARTIMENT MOTEUR</b></li> <li>• <b>L'ELECTROLYTE DE BATTERIE EST UN LIQUIDE TOXIQUE ET DANGEREUX. IL CONTIENT DE L'ACIDE SULFURIQUE, QUI PEUT PROVOQUER DE GRAVES BRULURES. EVITEZ TOUT CONTACT AVEC LA PEAU, LES YEUX ET LES VETEMENTS.</b></li> <li>• <b>LES BATTERIES PEUVENT DEGAGER DES GAZ EXPLOSIFS. ELOIGNEZ LES SOURCES D'ETINCELLES, LES FLAMMES NUES, LES CIGARETTES, ETC.</b></li> <li>• <b>LORSQUE VOUS CHARGEZ OU UTILISEZ UNE BATTERIE, OPEREZ EN UN ENDROIT BIEN VENTILE. PROTEGEZ TOUJOURS VOS YEUX LORSQUE VOUS TRAVAILLEZ A PROXIMITE D'UNE BATTERIE.</b></li> </ul>

<b>NOTE :</b>	<ul style="list-style-type: none"> <li><input checked="" type="checkbox"/> Lorsque vous n'utilisez pas votre bateau Zodiac® pendant un mois ou plus, retirez la batterie et rangez-la dans un endroit frais, sombre et sec. Rechargez complètement la batterie avant de la réutiliser</li> <li><input checked="" type="checkbox"/> Si la batterie doit être remise pendant une période plus longue, vérifiez la densité de l'électrolyte au moins une fois par mois et rechargez la batterie dès que la densité est trop basse. Densité de l'électrolyte : 1,28 à 20°C</li> </ul>
---------------	---

<b>NOTE :</b>	<p>Lorsque vous n'utilisez plus votre bateau, mettez le coupe-circuit sur la position OFF.</p>
---------------	--

# INSTALLATION ET CIRCUIT - Assèchement

## IV -3-ASSECHEMENT :

### IV -3-1-Description des éléments fonctionnels essentiels :

**Le bateau est auto videur, il est équipé de 4 gros vide-vite situés à l'arrière du pont.**

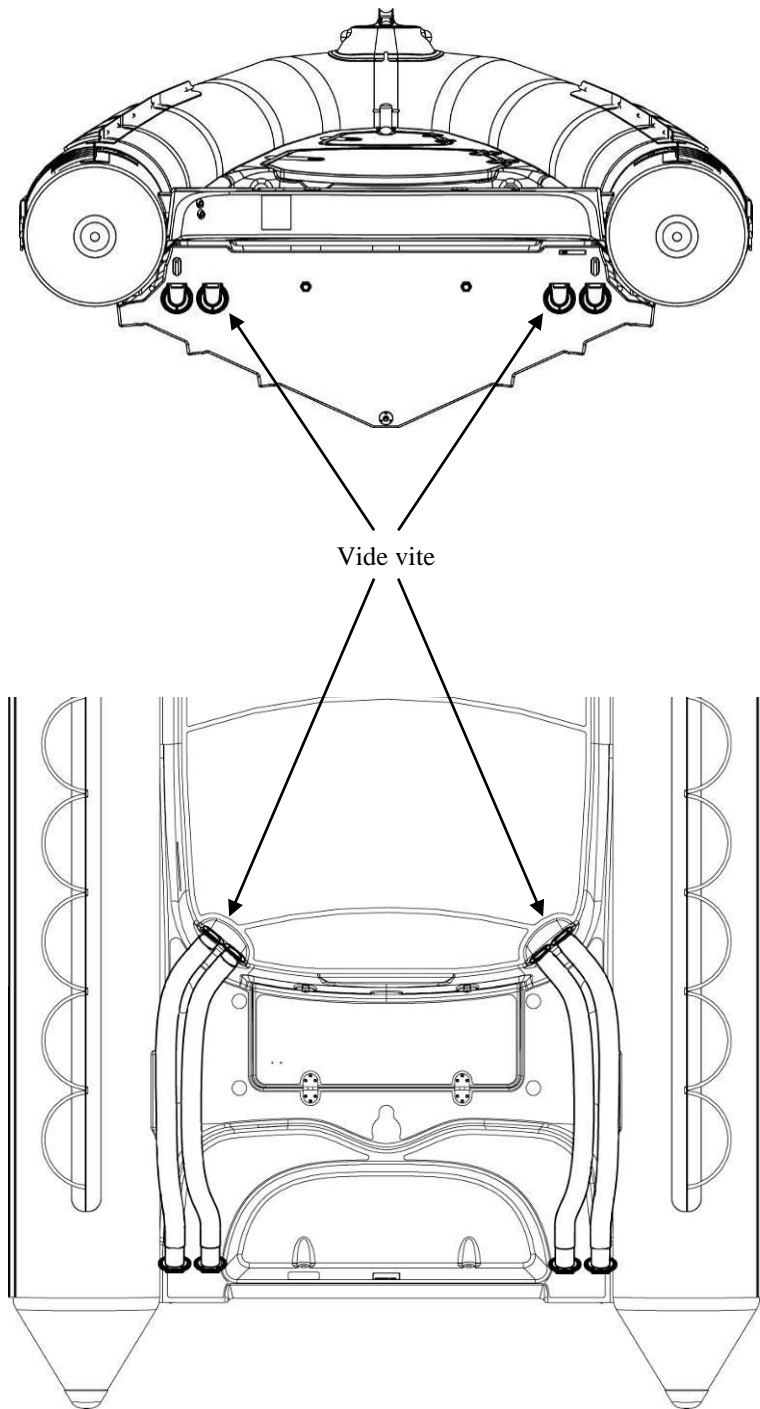

## INSTALLATION ET CIRCUIT - Assèchement

### IV-3-2-Nable de coque

#### IV-3-2-1-Bateau hors de l'eau (remorque, sur bers...)

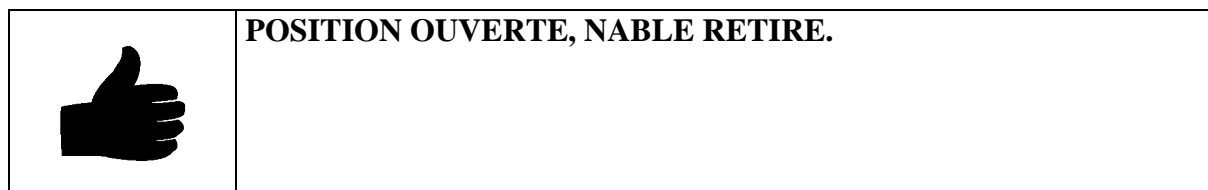

#### IV-3-2-2-Bateau à l'eau

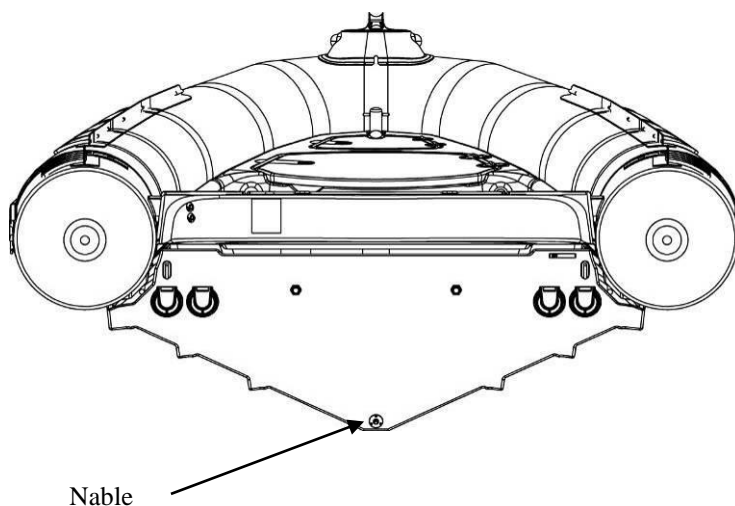
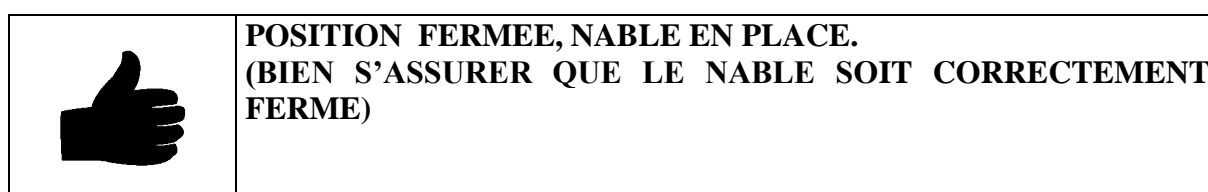

## INSTALLATION ET CIRCUIT - Direction

### IV-4-DIRECTION .

Un vérin hydraulique est fourni en série avec le bateau, il peut être utilisé pour le montage en mono moteur et dans certains cas en Bi motorisation (voir puissance maxi autorisée).

Conformez vous aux recommandations du constructeur de la direction (installation, utilisation et maintenance).

Pour une utilisation optimale de votre embarcation, veuillez consulter votre concessionnaire.

## INSTALLATION ET CIRCUIT - Incendie

### IV-5- INCENDIE



**AVERTISSEMENT**

**NOUS VOUS RECOMMANDONS D'AVOIR UN  
EXTINCTEUR A BORD, CONFORMEZ VOUS AUX LOIS  
EN VIGUEUR DE VOTRE PAYS.**

# INSTALLATION ET CIRCUIT - Mouillage/Amarrage

## IV-6- MOUILLAGE /AMARRAGE

### IV -6-1-Description des éléments fonctionnels essentiels :

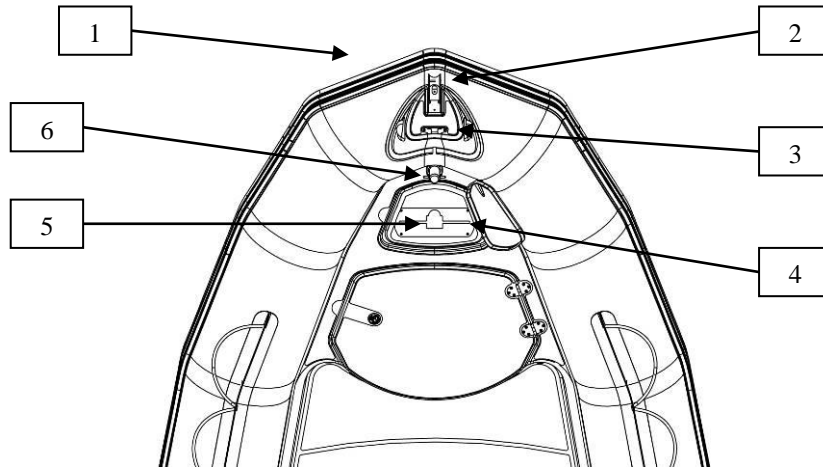

REPERE	DESIGNATION
1	Cadène d'étrave
2	Davier + Réa
3	Chaumard
4	Coffre à mouillage
5	Plaque repose ancre
6	Bitte amarrage

### IV -6-2-Utilisation :

 <b>AVERTISSEMENT</b>	<p><b>LA BITTE D'AMARRAGE, LES TAQUETS PERMETTENT UNIQUEMENT UN AMARRAGE OCCASIONNEL DU BATEAU.</b></p> <p><b>L'AMARRAGE PERMANENT DOIT SE FAIRE A L'AIDE DE LA CADENE D'ETRAVE SITUE A L'AVANT DU BATEAU.</b></p>
---	--

# SIGNALETIQUE

## V -1-POSITION DES AUTOCOLLANTS DE SECURITE ET PLAQUES SIGNALETIQUE

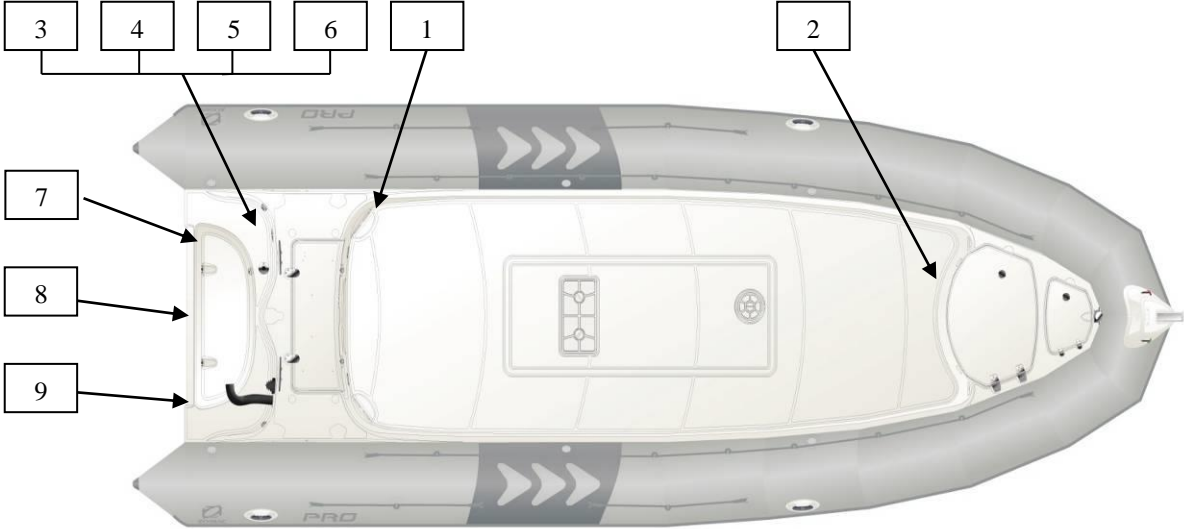

# SIGNALETIQUE

## V -2- DESCRIPTIF DES AUTOCOLLANTS DE SECURITE ET PLAQUES SIGNALETIQUE



⚠ WARNING	⚠ AVERTISSEMENTS
<ul style="list-style-type: none"> <li>• DO NOT TOUCH BATTERY TERMINALS (SHOCK AND ACID HAZARDS)</li> <li>• DISCONNECT BOTH LEADS BEFORE REMOVING BATTERY</li> <li>• CONNECT RED LEAD TO POSITIVE (+) TERMINAL</li> <li>• CONNECT BLACK LEAD TO NEGATIVE (-) TERMINAL</li> </ul>	<ul style="list-style-type: none"> <li>• NE PAS TOUCHER LES TERMINAUX DE LA BATTERIE (RISQUE DE CHOC ELECTRIQUE ET DE CONTACT AVEC L' ACIDE DE LA BATTERIE)</li> <li>• DEBRANCHER LES 2 FILS DE SORTIE AVANT DE RETIRER LA BATTERIE</li> <li>• RELIER LE CABLE ROUGE A LA BORNE (+)</li> <li>• RELIER LE CABLE NOIR A LA BORNE (-)</li> </ul>

1



⚠ WARNING	⚠ AVERTISSEMENTS
<p style="text-align: center;"><b>GASOLINE IS HIGHLY INFLAMMABLE AND EXPLOSIVE</b></p> <ul style="list-style-type: none"> <li>• STOP ENGINE BEFORE REFUELING</li> <li>• REFUEL IN WELL VENTILATED AREA</li> <li>• NEVER REFUEL WHILE SMOKING, AROUND SPARKS OR OPEN FLAME</li> <li>• AVOID SPILLING FUEL. WIPE UP ALL FUEL SPILLS IMMEDIATELY</li> <li>• LEAKING FUEL IS A FIRE HAZARD AND EXPLOSION HAZARD</li> <li>• INSPECT FUEL SYSTEM BEFORE EACH USE</li> </ul>	<p style="text-align: center;"><b>L' ESSENCE EST TRES FORTEMENT INFLAMMABLE ET EXPLOSIVE</b></p> <ul style="list-style-type: none"> <li>• ARRETER LE MOTEUR AVANT TOUT REMPLISSAGE.</li> <li>• NE PAS FUMER LORS DU REMPLISSAGE.</li> <li>• FAIRE LE PLEIN DANS UN ENDROIT VENTILE.</li> <li>• EVITER DE RENSER DU CARBURANT. ESSUYER IMMEDIATEMENT TOUTES LES FLAQUES DE CARBURANT CREES</li> <li>• LES FUITES DE CARBURANTS CONSTITUENT UN RISQUE D' INCENDIE ET D' EXPLOSION</li> <li>• VERIFIER LE CIRCUIT CARBURANT AVANT CHAQUE UTILISATION</li> </ul>

2

⚠ CAUTION	⚠ ATTENTION
<p style="text-align: center;"><b>IMPROPERLY TOWING YOUR BOAT CAN CAUSE SEVERE DAMAGE TO YOUR BOAT.</b></p> <ul style="list-style-type: none"> <li>• NEVER TOW IN OPEN SEAS</li> <li>• NEVER TOW ABOVE 6 KNOTS</li> </ul>	<p style="text-align: center;"><b>UN REMORQUAGE INAPROPRIE PEUT ENDOMMAGER VOTRE BATEAU</b></p> <ul style="list-style-type: none"> <li>• NE PAS REMORQUER EN PLEINE MER</li> <li>• NE PAS REMORQUER A PLUS DE 6 NOEUDS</li> </ul>

3

⚠ WARNING	⚠ AVERTISSEMENT
<p style="text-align: center;"><b>DO NOT LIFT THE BOAT WITH PASSENGERS ON BOARD</b></p>	<p style="text-align: center;"><b>NE PAS SOULEVER LE BATEAU AVEC DES PASSAGERS A BORD</b></p>

4

## SIGNALETIQUE

<b>DANGER</b> TO AVOID INJURY OR DEATH, SHUT OFF ENGINE WHEN NEAR SWIMMERS OR PRIOR TO USING SWIN PLATFORM AND BOARDING LADDER	<b>DANGER</b> POUR EVITER DES BLESSURES OU LA MORT, COUPER LE MOTEUR EN APPROCHANT DE NAGEURS, ET AVANT TOUTE UTILISATION DE LA PLATEFORME ARRIERE OU DE L' ECHELLE DE BAIN
---	--

5

<b>DANGER</b> A FIRE EXTINGUISHER MUST BE CARRIED AT ALL TIMES	<b>DANGER</b> UN EXTINCTEUR DOIT ETRE DISPONIBLE EN PERMANENCE A BORD
---	--

6

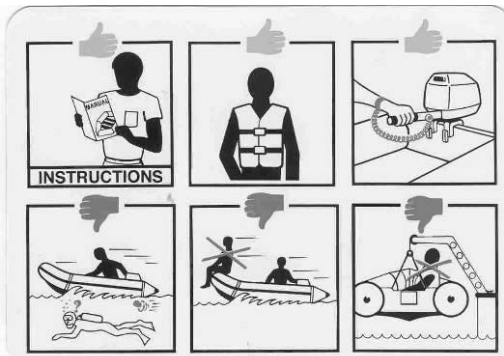

7

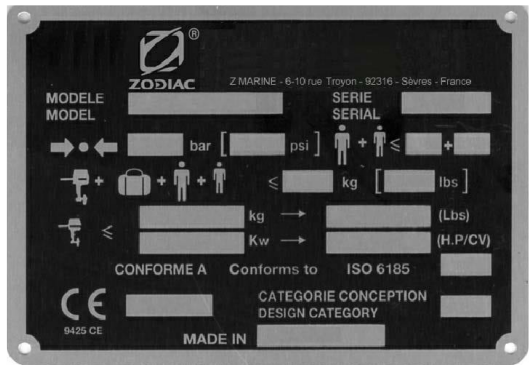

8



9

	<b>VEUILLEZ VOUS ASSURER DE LA PRESENCE ET DE LA LISIBILITE DES AUTOCOLLANTS. VEUILLEZ CONTACTER VOTRE REVENDEUR POUR VOUS EN PROCURER DE NOUVEAUX SI NECESSAIRE.</b>
--	---





## EMPLACEMENT ACCESSOIRES OPTIONNELS

### VI -1-EMPLACEMENT CONSOLE T4. (Quelle que soit la catégorie de navigation B ou C)

Votre bateau peut être équipé d'une console optionnelle appelée T4 (Voir votre revendeur Zodiac).

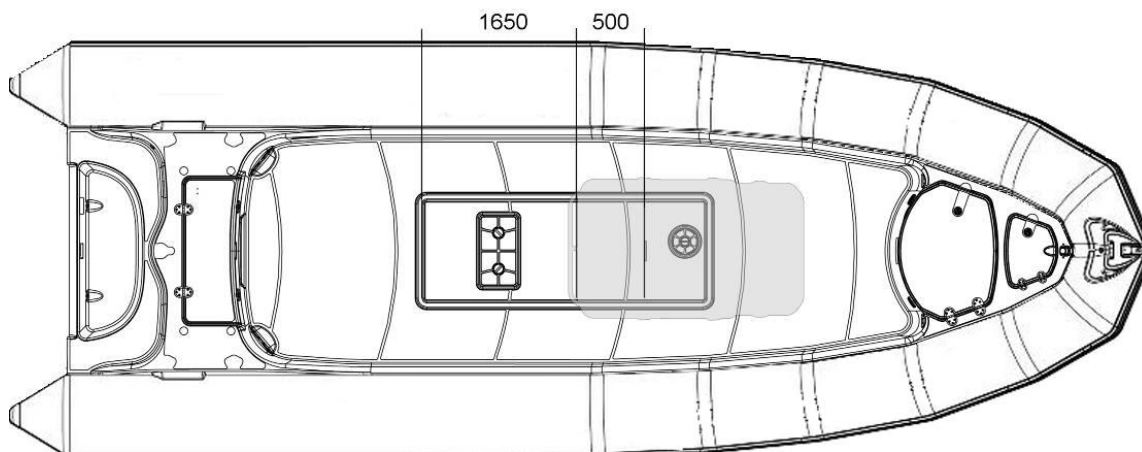
Dans le but, d'optimiser l'utilisation du bateau et de bénéficier de tous les accès sous le pont (accès réservoir/ câblage électrique et passage des câbles), nous vous recommandons de la placer dans la zone spécifiée ci-dessous.



 <b>AVERTISSEMENT</b>	<b>POUR BENEFICIER DU PASSAGE DES CABLES SOUS LE PONT ET AFIN DE NE PAS DETERIORER LA STRUCTURE DU BATEAU, LE PASSE CABLES (NON FOURNI) DOIT IMPERATIVEMENT ETRE PLACE SUR LA ZONE GRISEE INDIQUEE CI-DESSUS.</b>
---	---

### VI-1-2-PASSAGE DES CABLES :

Le passage des câbles et durites essence moteur est prévu sous le pont du bateau. (Par des gaines pré installées en usine).

Sortie des câbles sur le pont (à l'aide d'un passe câbles).

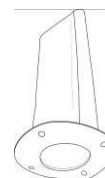

Zone passage des câbles

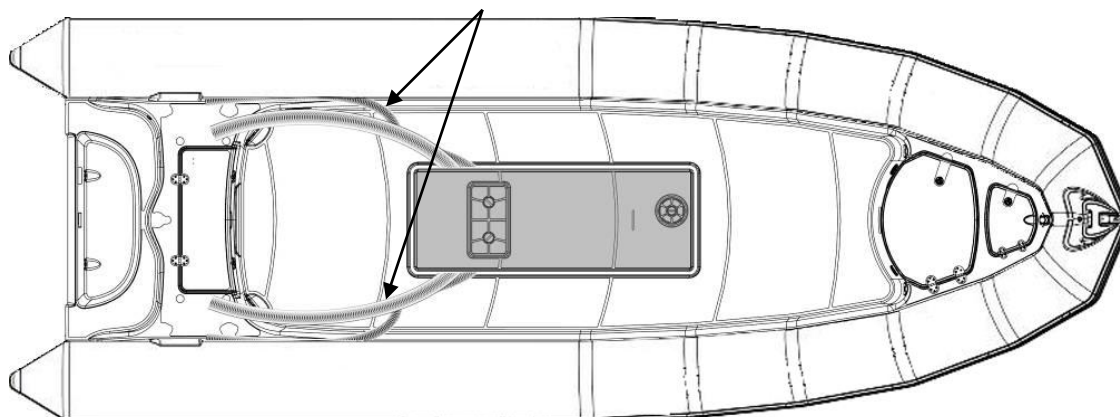

## EMPLACEMENT ACCESSOIRES OPTIONNELS

 <b>AVERTISSEMENT</b>	<p><b>POUR DES RAISONS DE SECURITE, L'OUVERTURE DE LA TRAPPE ACCES RESERVOIR DOIT RESTER ACCESSIBLE ET NE DOIT PAS ETRE GENEES PAR LA POSITION D'UN ACCESSOIRE. ELLE PEUT CEPENDANT SE TROUVER ENTIEREMENT RECOUVERTE PAR LA CONSOLE, MAIS RESTER ACCESSIBLE PAR LE COFFRE AVANT DE CETTE DERNIERE.</b></p>
---	---

 <b>ATTENTION</b>	<p><b>NE JAMAIS PERCER DANS LA ZONE RESERVOIR AVEC UN FORET DEPASSANT DE PLUS DE 30MM DU MANDRIN DE LA PERCEUSE ET NE PAS UTILISER DES VIS DE PLUS DE 20 MM DE LONGUEUR.</b></p>
---	--

### VI-1-3-Position accessoires SIEGE T4 / BOLSTER T4. (suivant catégorie de conception)

Suivant la catégorie de navigation dans laquelle on veut utiliser le bateau voici 2 emplacements de siège ou bolster répondant au nombre de place assise requise.

#### VI-1-3-1-catégorie C.

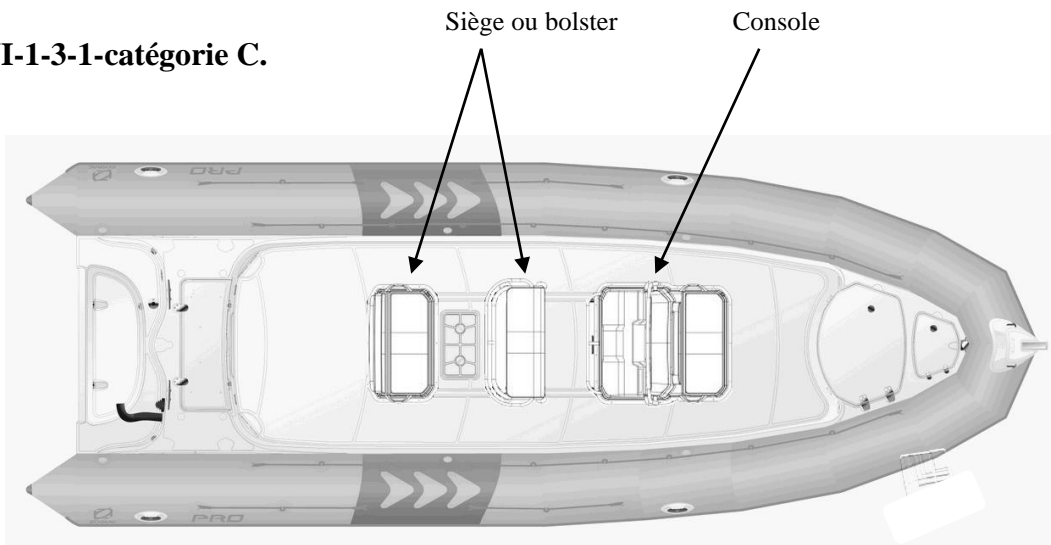

**VI-1-3-1-catégorie B. Le nombre de personne en catégorie B est limité à 10 toutes les personnes doivent être assises.**

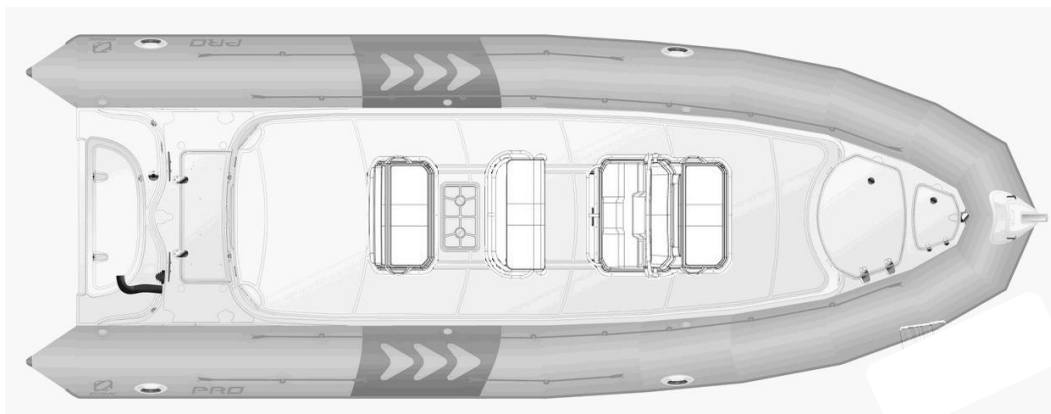

# EMPLACEMENT ACCESSOIRES OPTIONNELS

**VI-1-4-Position accessoire ROLL BAR. (des notices plus détaillées sont livrées avec chaque options).**

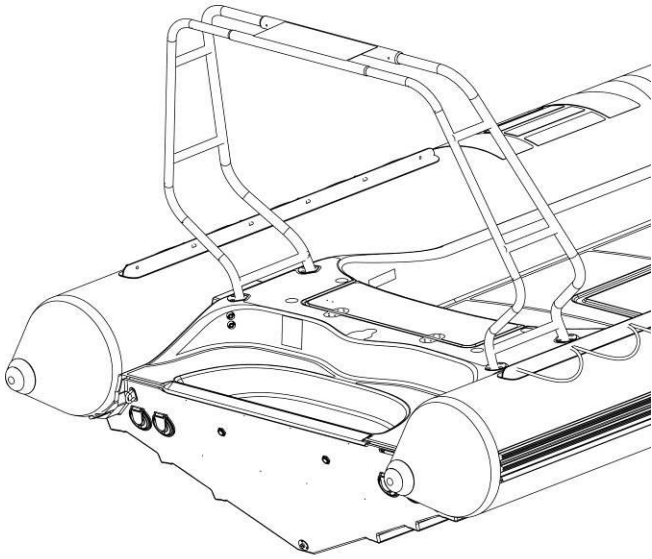

**VI-1-5-Position accessoire Mat de ski / Dossier arrière.**

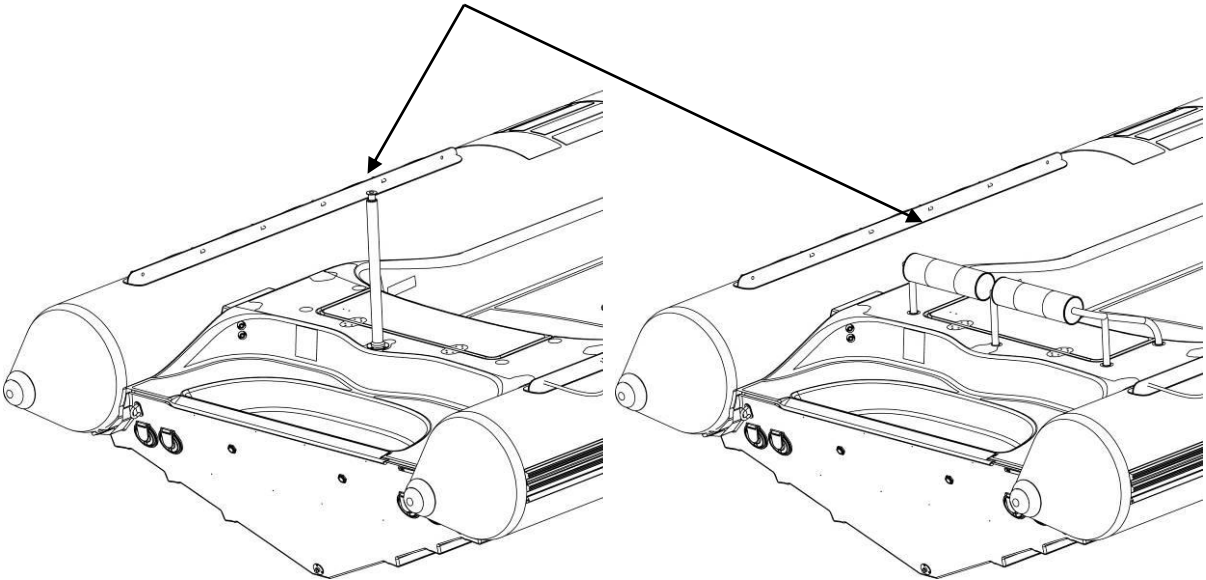

 <p><b>ATTENTION</b></p>	<p><b>NE JAMAIS UTILISER LE MAT DE SKI POUR UNE AUTRE UTILISATION, QUE LE SKI NAUTIQUE OU WAKE. POUR LE REMORQUAGE OU LE TRACTAGE DE BOUEE DE MER, UTILISER LES CADENES ARRIERES</b></p>
---	--



# EMPLACEMENT ACCESSOIRES OPTIONNELS

VI-1-6-Position accessoire T-TOP.

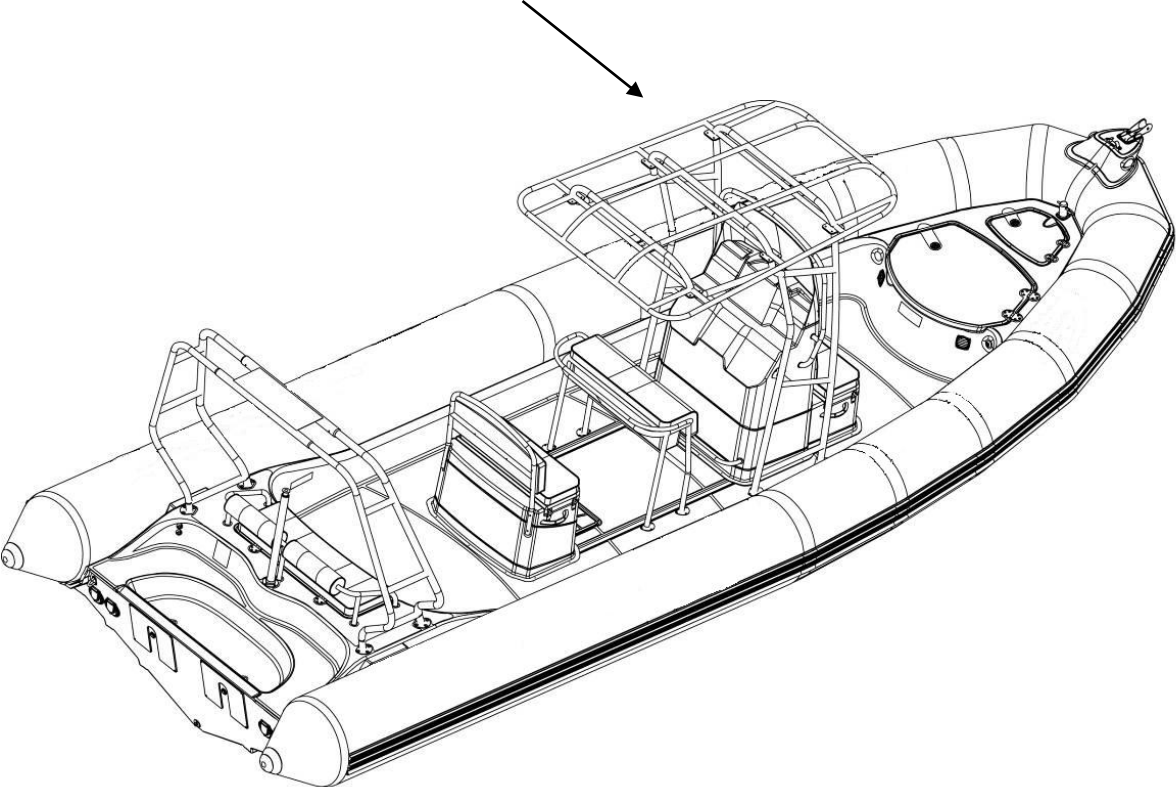



6-10 Rue Troyon  
92316- Sèvres - France

[www.zodiacmarine.com](http://www.zodiacmarine.com)

Pro 850

Code ZR20230

Edition 4



# **PRO**

## **PRO 850**

*Tome 2 – Volume 2*

*Teil 2 – Tomo 2*

7R20230

Edition 4



LIRE ATTENTIVEMENT CE MANUEL AVANT LA MISE EN SERVICE DE VOTRE ZODIAC.  
CAREFULLY READ THIS MANUAL BEFORE OPERATING YOUR ZODIAC.  
LEGGERE ATTENTAMENTE PRIMA DE INIZIARE IL MONTAGGIO DEL VOSTRO ZODIAC.  
VOR INBETRIEBNAHME IHRES ZODIAC VORLIEGENDES HANDBUCH AUFMERKSAM LESEN.  
LEER CUIDADOSAMENTE ESTE MANUAL ANTES DE PONER EN SERVICIO SU ZODIAC.



**Owner's Manual  
Volume 2**

**PRO 850**

**VOLUME 2  
DESCRIPTION – BUOYANCY MECHANISM  
PROPULSION SYSTEM  
INSTALLATION AND CIRCUITS**







# CONTENTS

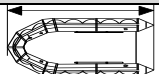

	PAGE
⇒ I – GENERAL DESCRIPTIONS	
I-1-Technical characteristics -----	3 - 5
I-2-Technical description-----	6
I-3-Item location-----	7 - 8
I-4-Handling-----	9
⇒ II – BUOYANCY MECHANISM	
II-1-Assembling the buoyancy mechanism on the hull-----	10
II-2-Fixing the flap-----	11
II-3-Inflation mechanism -----	12 – 13
II-4-Pressure-----	14 - 15
⇒ III -PROPULSION SYSTEM	16
⇒ IV - INSTALLATION AND CIRCUITS	
IV-1-Fuel -----	17 - 20
IV-2-Electricity -----	21 – 35
IV-3-Drainage -----	36 - 37
IV-4-Steering -----	38
IV-5-Fire-----	38
IV-6-Anchoring/Mooring-----	39
⇒ V – INFORMATION AND IDENTIFICATION PLATES	
V-1-Safety label and registration plates position -----	40
V-2-Safety label and registration plates description -----	41 - 42
⇒ VI – POSITIONING / ASSEMBLY OF OPTIONAL ACCESSORIES	
VI-1-Console position-----	43 - 44
VI-2-Seat / bolster position-----	44
VI-3-Rollbar position-----	45
VI-4-Ski mast / rear seatback-----	45
VI-5-T-TOP position-----	46

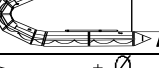

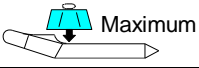
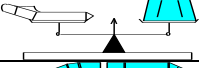

# DESCRIPTION - Technical Characteristics

## I-1-TECHNICAL CHARACTERISTICS

Dimensions		
	(m)	8.5
	(ft)	27'10"
	(m)	7.45
	(ft)	24'5"
	(m)	3
	(ft)	9'10"
	(m)	1.85
	(ft)	6'
	(m)	0.6
	(ft)	1'11"

Design category	
 (Directive 94/25/CE)	B / C

Capacity			
 (ISO)		B=10	C=20
	<b>Kg</b> <sup>(1)</sup>	2050	2800
	<b>lb.</b> <sup>(1)</sup>	4519	6173
	<b>Kg</b> <sup>(2)</sup>	1350	1350
	<b>lb.</b> <sup>(2)</sup>	2976	2976
 <b>Compartment</b>		7	

Motorisation				
Shaft length		SINGLE ENGINE		TWIN ENGINE
		XXL		XL
	Minimum power recommended	HP <sup>(3)</sup>	250	2 x 175
		kW <sup>(3)</sup>	187	2 x 131
	Maximum power recommended	CV	300	2 x 225
		kW	225	2 x 166
	Maximum power authorised	HP <sup>(3)</sup>	300	2 x 225
		kW <sup>(3)</sup>	225	2 x 166
	Maximum engine weight	kg	393	2 x 272
		lbs	866	2 x 600

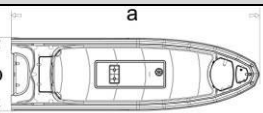
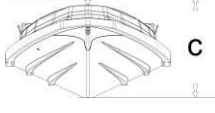
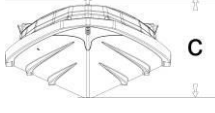
Hull dimensions (excluding options)		
	a <sup>(4)</sup> (m)	7,78
	(ft)	25'6"
	b <sup>(4)</sup> (m)	2,27
	(ft)	7'5"
	c <sup>(4)</sup> (m)	1,37
	(ft)	4'5"

## DESCRIPTION - Technical Characteristics

**Category conception :** Your boat has been built for B & C category. It means different layouts/ passengers and payload capacity for each category.

The B category allows to navigate with 10 passengers. Each passenger has to be seated and have possibility to hold on to the boat.

We recommend you to use the specific Zodiac accessories (contact your dealer).

### Position of accessories SEAT / BOLSTER (per design category)

Depending on the navigation category in which the boat is used, the diagram below shows 2 positions for the seat or bolster depending on the number of seats required.

#### -C Category.

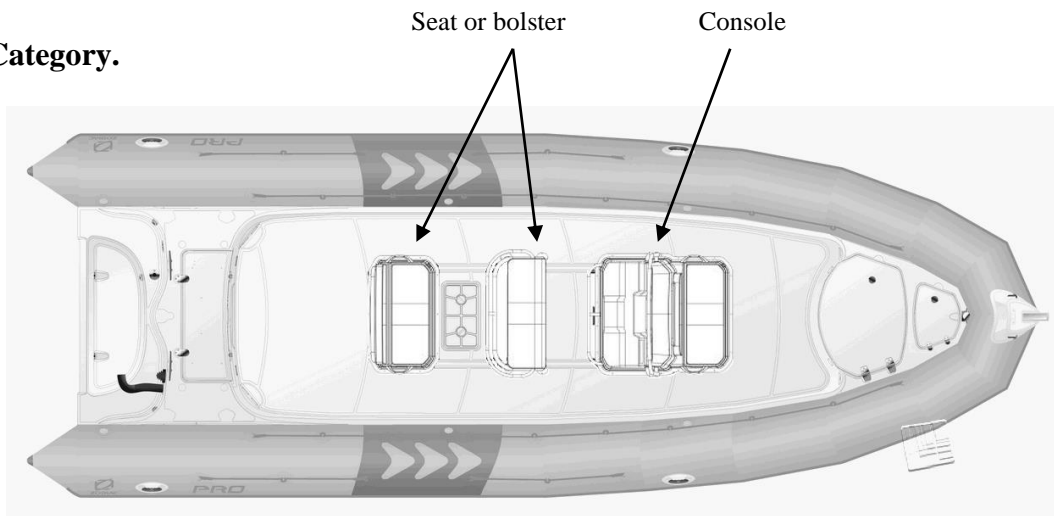

#### - B Category.

- The number of persons in category B is limited to 10, all seated.

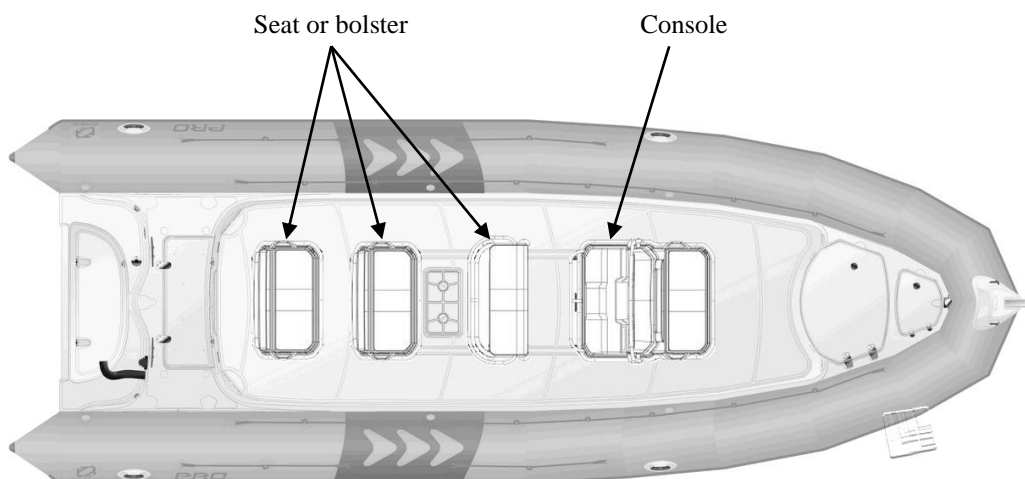

<b>NOTE</b>	<b>Dimension tolerances: +/- 4%</b> <b>Weight tolerances: +/- 5%</b>
-------------	---

<b>NOTE</b>	<p><sup>(1)</sup> <b>The maximum authorized load was calculated to standard ISO 6185. Navigate carefully when the boat carries the maximum load.</b></p> <p><sup>(2)</sup> <b>Weight shown not including accessories</b></p> <p><sup>(3)</sup> <b>The recommended power corresponds to optimum operation of the boat's capabilities for an average load.</b></p> <p><sup>(4)</sup> <b>Hull dimensions without buoyancy mechanism.</b></p> <p><b>Use the maximum authorised power with extreme prudence (see Volume 1 of the manual "Navigation advice")</b></p>
-------------	---

 <b>CAUTION</b>	<p><b>DO NOT EXCEED THE MAXIMUM LOAD ON THE MANUFACTURER'S PLATE. THE MAXIMUM LOAD INCLUDES THE WEIGHT OF THE ENGINE(S), FUEL, ACCESSORIES, PASSENGERS AND THEIR EQUIPMENT AND ANY OTHER TYPE OF LOAD.</b></p>
---	--

 <b>CAUTION</b>	<p><b>DO NOT STORE FLAMMABLE PRODUCTS IN THE AFT COMPARTMENT. IT IS STRICTLY FORBIDDEN TO STORE A JERRYCAN.</b></p>
---	---

## TUBE - Cleaning

This boat's tube is made with Hypalon™ Néoprène™ 1670 dtex fabric.

For a better maintenance we recommend to clean the tube with soapy water or ecological cleaner like Revival, available in your Zodiac dealer shop.

 <b>ATTENTION</b>	<p><b>DO NOT USE CLEANER WITH SOLVENT LIKE ACETATE</b></p>
---	--

# TECHNICAL DESCRIPTION

## I -2-INVENTORY

<b>HULL</b>
• Polyester hull
• Counter-moulded non-slip deck
• 1 bow ring
• 1 anchoring rope locker
• 1 sheave-hole
• 1 mooring cleat + 2 rear cleats
• 1 forward chest + removable chest (75 litres)
• 1 rear chest
• 2 tension chain plates
• 1 hull plug hole
• 4 quick drain holes
• 1 400-litre tank
• 1 fuel/water separator filter
• 1 fuel circuit valve/ gauge circuit essence access hatch
• 1 fuel pipes connection access hatch
• Electrical circuit with battery couplers and circuit breaker.
• 2 bilge pumps
<b>BUOYANCY MECHANISM</b>
• Removable buoyancy mechanism made of STRONGAN DUOTEX 2 X 1100 Decitex fabric
• 7 Semi built-in valves “easy-push”
• Anti-chafing band with ultra-wide profile
• 4 external handles
• 2 patches
• lashing
• Short cones
• 1 davit + rea + cleat + lights
<b>STANDARD EQUIPMENT</b>
• 2 paddles
• Foot inflation pump
• Manometer
• Repair kit
<b>OPTIONAL ACCESSORIES*</b>
• Console
• Seat
• Bolster
• Rear seatback
• Ski pylon
• Roll bar
• T-top
• Bathing ladder
• 4- and 6-cylinder racks
• Electrical inflator.

\* For more information on available optional accessories see your ZODIAC dealer.

# DESCRIPTION - Functional Elements

## I-3-LOCATION OF ELEMENTS

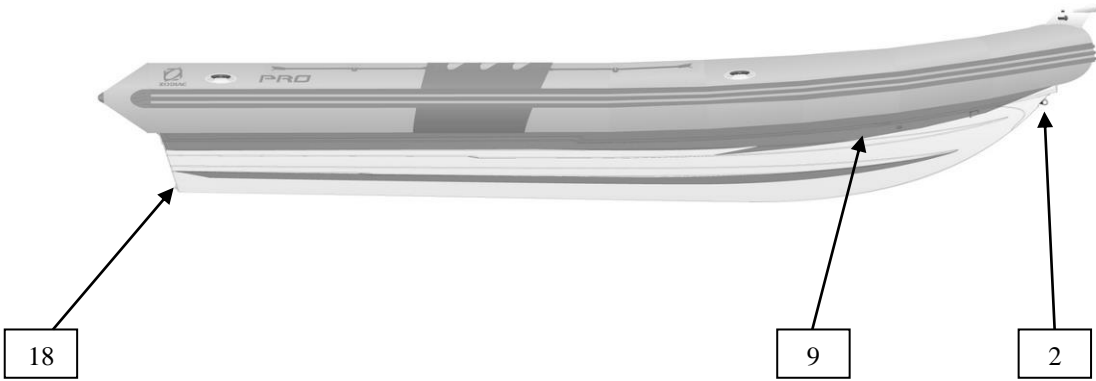
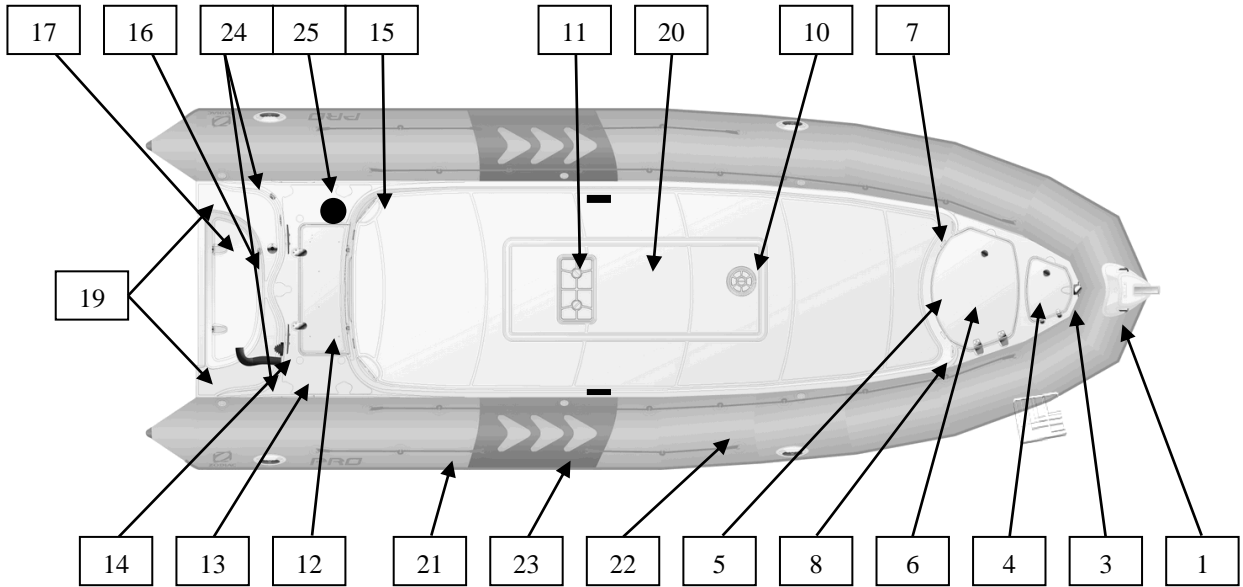

E  
N  
G  
L  
I  
S  
H

## DESCRIPTION - Functional Elements

MARK	DESIGNATION
1	1 davit + rea + cleat + lights
2	Bow ring
3	mooring cleat
4	Anchoring rope locker cover
5	Fuel filling point
6	Removable 75-litre chest
7	Tank compartment ventilation grid
8	Tank vent
9	Fuel overflow drainage
10	Tank hose access hatch.
11	Tank valve/gauge access hatch.
12	Rear cover
13	Fuel/water separator filter
14	Engine cable feedthrough
15	Quick drain hole
16	Rear trough
17	Trough outlets
18	Hull plug hole
19	Rear chain plates
20	Tank
21	Buoyancy mechanism
22	Lashing
23	Pro logos
24	Rear cleat
25	White light slot

## DESCRIPTION - Handling

### I-4-HANDLING

#### I-4-1-Transport:

- Advice for fitting to a trailer is given in the owner's manual, Volume 1.

#### I-4-2-Storage:

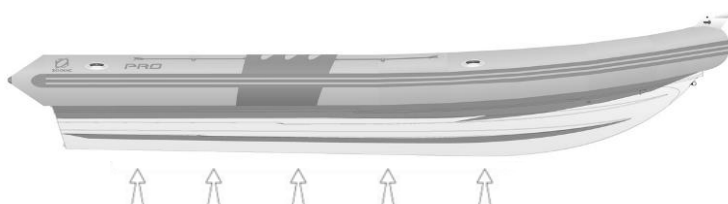

 <b>CAUTION</b>	<b>THE BOAT MUST REST ON THE BOW (SEE SKETCH BELOW)</b>
---	---

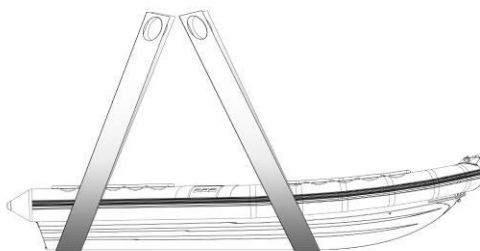

#### I-4-3-Lifting: The boat has no lifting devices.

 <b>WARNING</b>	<b>THE BOAT HAS NO LIFTING DEVICE SO HOISTING REQUIRES PASSING SUITABLE LIFTING STRAPS UNDER THE HULL. FOR THIS OPERATION USE PROFESSIONAL LIFTERS.</b>
---	---



 <b>ATTENTION</b>	<b>NO PASSENGERS ON BOARD WHILE LIFTING</b>
 <b>WARNING</b>	<b>ALL EQUIPMENT MUST BE UNLOADED FROM THE BOAT FOR LIFTING.</b>  <b>BEFORE LAUNCHING THE BOAT, OPEN THE PLUG HOLE (18) TO DRAIN ANY RAINWATER FROM THE COCKPIT (CLOSE THE PLUG HOLE AGAIN BEFORE LAUNCHING).</b>



# BUOYANCY MECHANISM – Assembly on the Hull

## II-1-ASSEMBLING THE BUOYANCY MECHANISM ON THE HULL

1

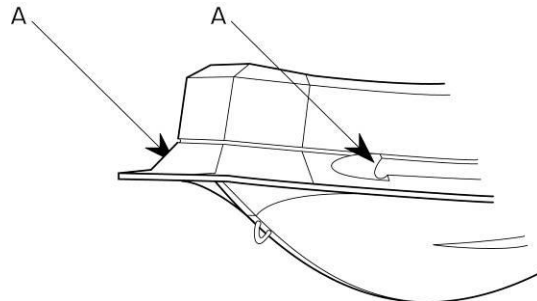

To facilitate the positioning of the buoyancy mechanism, apply liquid soap (A) to the hull rails

2

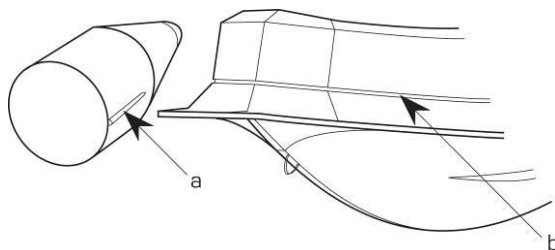

Place the bolt rope (a) of the buoyancy mechanism in the hull rail (b) located in the bow of the hull. Pull on the buoyancy mechanism until the mini-bolt rope faces the rail.

3

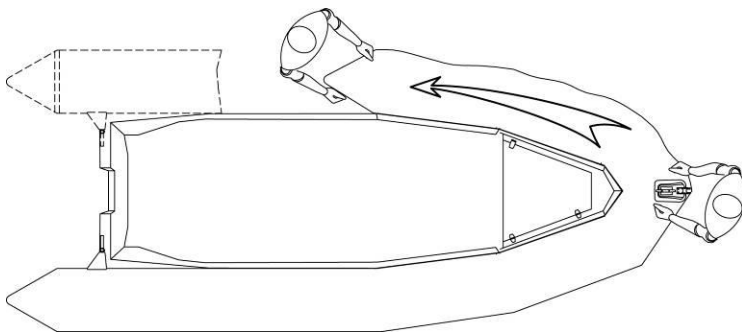

- Proceed in the same way for the other side of the buoyancy mechanism.
- Move the tip of the buoyancy mechanism forwards to fold the outer flap down under the tip of the hull.
- Pull the 2 tabs of the buoyancy mechanism again as far as possible towards the aft end of the boat, and try to centre the tip with the bow of the hull.
- Slightly inflate the tip of the buoyancy mechanism to check that it has been well centred and that it matches the hull perfectly. Begin the operation again if the buoyancy mechanism is not correctly positioned.

# BUOYANCY MECHANISM - Fixing the Flap

## II-2-FIXING THE FLAP

4

Fix the external flap using the stainless steel bars and bolts of the buoyancy mechanism kit. Apply sealing compound on all the screws and in the hull holes to achieve final tightness.

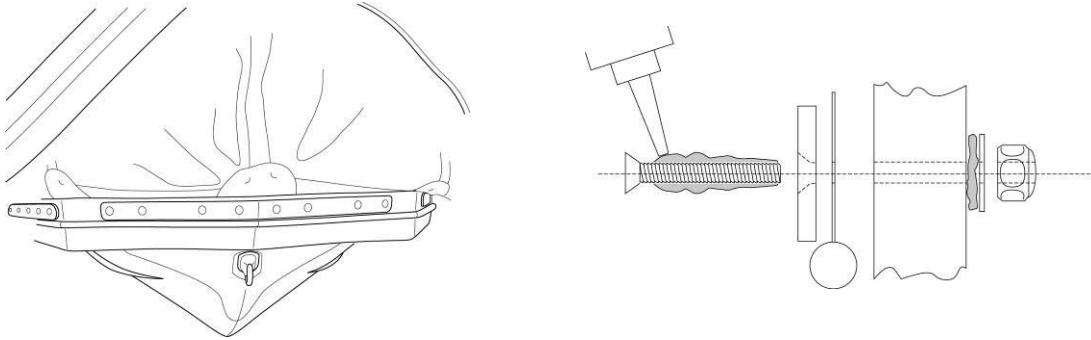

**NOTE:**

**The buoyancy mechanism is mounted on the hull deflated.**



You may inflate the buoyancy mechanism disassembled (pressure 240 mb) and let it stabilize for approximately one hour. Then deflate it.



If the buoyancy mechanism was stored at a temperature lower than 0 °C, leave it 12 hours at room temperature (20 °C) before folding it.

# BUOYANCY MECHANISM - Inflating System

## II-3-INFLATING SYSTEM

### II -3-1- The inflation pump

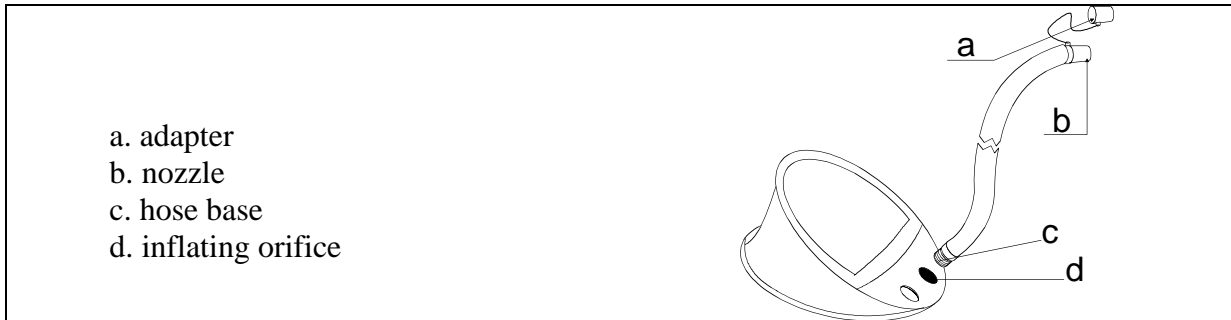

\* A fast electrical inflator (12 V) is available as an option (contact your dealer).

### II -3-2- Valves

#### EASY PUSH VALVES

To change position	In inflating position	In deflating position
 Push	 The membrane is closed, the knob is up	 The membrane is open, the knob is down

<b>NOTE:</b>	<b>ALWAYS REFIT THE VALVE PLUG AFTER INFLATING OR DEFLATING</b>
--------------	---

# BUOYANCY MECHANISM - Inflating System

## II -3-3- Pressure gauge

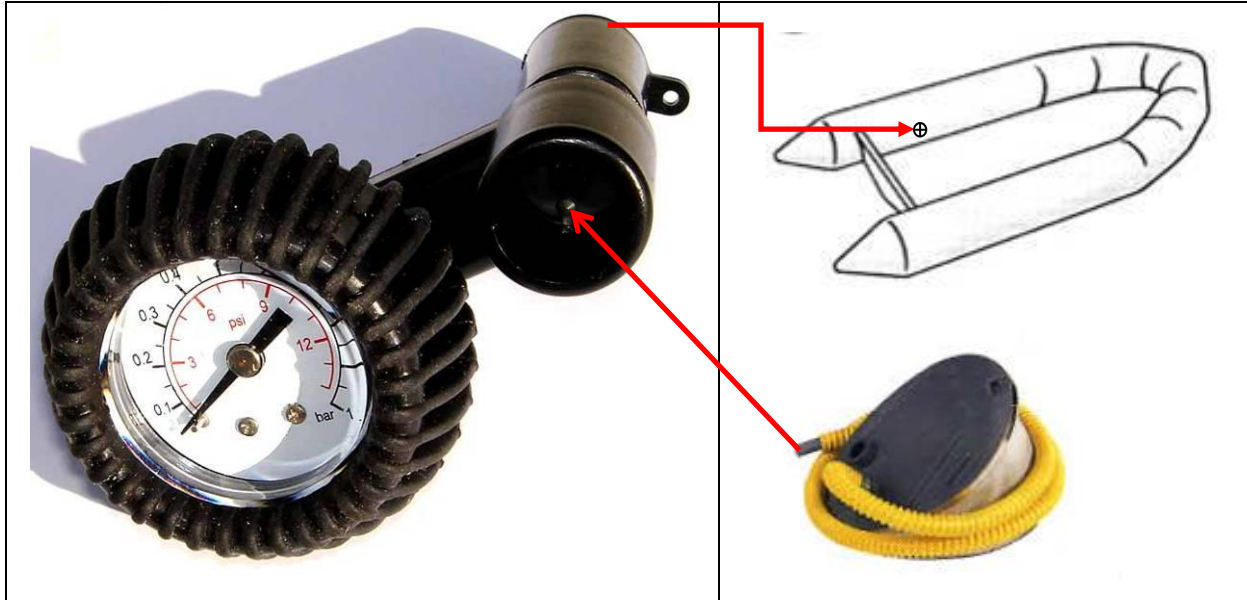

E  
N  
G  
L  
I  
S  
H

## II -3-4- Buoyancy mechanism inflation

Activate all valves in inflating position

Fix the hose base in the inflator inflating orifice

To inflate your boat properly, the inflator should be correctly placed on the ground.

The boat inflates rapidly if the inflator is used smoothly and without haste.

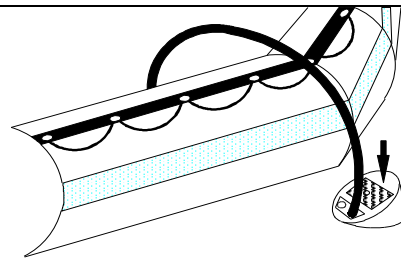

**DO NOT USE A COMPRESSOR OR COMPRESSED AIR CYLINDER**

# BUOYANCY MECHANISM - Pressure

## II -4-1- Buoyancy mechanism inflation

- Place the adapter corresponding to the diameter of the semi built-in valve at the inflator hose nozzle.

Inflate the buoyancy mechanism, **balancing the pressure between the different compartments until the partitions (a) are no longer visible (pressure = 240 mb)**

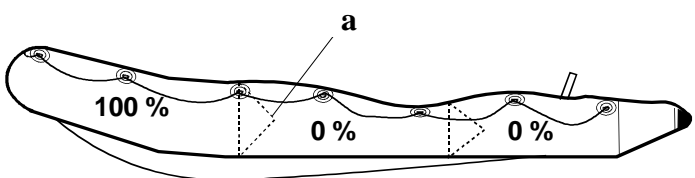
	Never pressurise a compartment when the others are completely deflated	
---	--	--

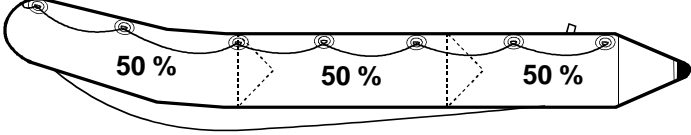
	1	
---	---	--

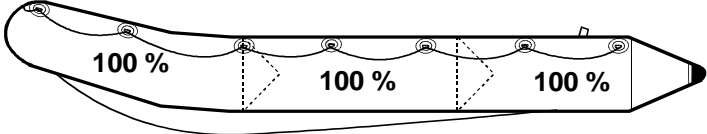
	2	
--	---	---

**Inflating is complete:** Screw on the inflating valve caps

<b>NOTE:</b>	<b>A slight air leak is normal before the valve cap is screwed on Only the caps guarantee final air tightness</b>
--------------	---

## II-4-2- Pressure

**Operating pressure for the buoyancy mechanism is 240 mb/ 3.4 PSI** (middle of the green zone of the pressure gauge).

Your boat is equipped with an *ACCESS* pressure indicator that will enable you to read the pressure quickly and efficiently during inflating (see explanations for use in the section Inflating System).

The ambient temperature of the air or water proportionately influences the level of internal pressure in the buoyancy mechanism	Ambient Temperature	Internal buoyancy mechanism pressure
	+1°C	+4 mb / 0.06 PSI
	-1°C	-4 mb / 0.06 PSI

# BUOYANCY MECHANISM - Pressure

Thus, it is important to anticipate:

Check and adjust the pressure in the inflatable compartments (re-inflating or deflating as necessary) according to temperature variations (especially when the temperature varies greatly between the morning and evening in hot climates) and ensure that the pressure is within the recommended pressure zone (from 220 to 270 mb/green zone).

## RISK OF UNDERPRESSURE:

**EXAMPLE:** Your boat is exposed on a beach in the sun (temperature=50 °C) at the recommended pressure (240 mb/3.4 PSI). When you launch it (temperature=20 °C), the temperature and internal pressure of the inflatable compartments will drop simultaneously (up to 120 mb) and **YOU WILL THEN NEED TO REFLATE** until you regain the millibars lost due to the difference between the ambient air and water temperatures. A drop in pressure at the end of the day, when the outside temperature is dropping, is normal.

## RISK OF OVERPRESSURE

**EXAMPLE:** Your boat is inflated to its recommended pressure (240 mb/3.4 PSI) at the beginning or end of the day (low outside temperature = 10 °C). Later in the day, your boat is exposed in the sun on the beach or on a yacht deck (temperature = 50 °C). The temperature inside the inflatable compartments may rise to 70 °C (particularly for dark buoyancy mechanisms), doubling the initial pressure (480 mb). **YOU WILL THEN NEED TO DEFLATE** the boat to return to the recommended pressure.



CAUTION

**IF YOUR BOAT IS OVERINFLATED, THERE WILL BE UNDUE PRESSURE ON THE INFLATABLE STRUCTURE THAT MAY RUPTURE IT.**

## IN CASE OF OVERPRESSURE

**“EASY-PUSH” VALVE**  
Release some air by pressing the valve knob.

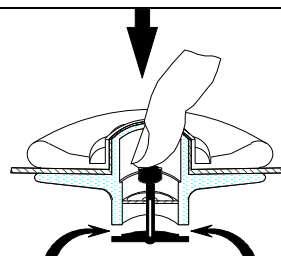

# PROPULSION SYSTEM

Comply with ZODIAC recommendations and engine constructor recommendations regarding engine assembly.

For optimum use of your boat, see your dealer.

# INSTALLATION AND CIRCUIT - Fuel

## IV-1-FUEL

### IV -1-1-Description of essential functional parts:

The boat is factory-mounted with a 400-litre tank located under the deck. It is filled at the prow, via a filling port below the front hood.

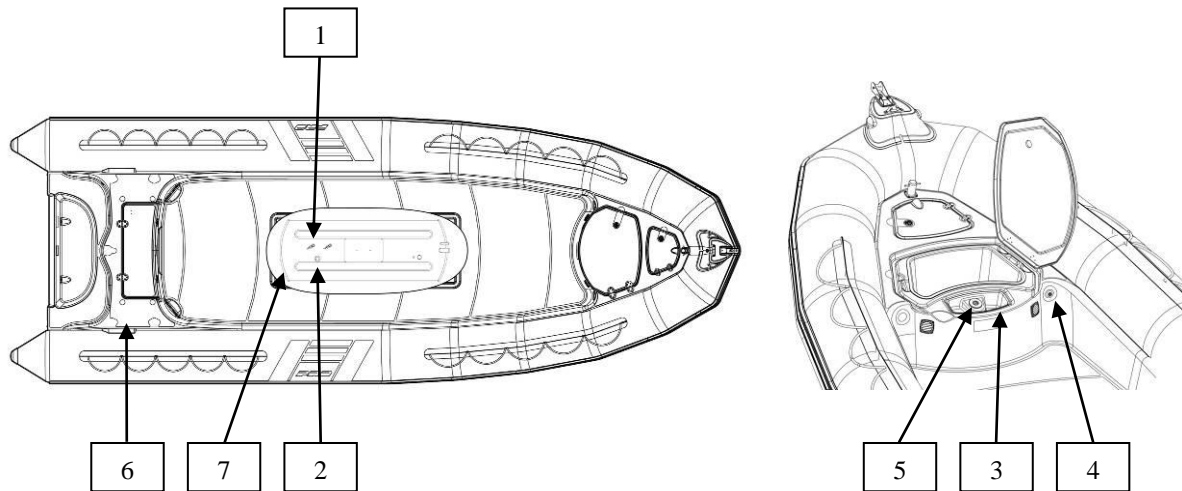

MARK	DESIGNATION
1	Fuel circuit closing valve
2	Gauge transmitter
3	Draining hole of the overflow compartment
4	Vent
5	Filling hole
6	Fuel/water separator filter (supplied for single-engine configuration)
7	Fuel tank

 <b>WARNING</b>	<p><input checked="" type="checkbox"/> <b>IN SINGLE-ENGINE CONFIGURATION, REMEMBER TO CLOSE THE FUEL VALVE OF THE SECOND ENGINE.</b></p>
---	--

### IV -2-1-Tank

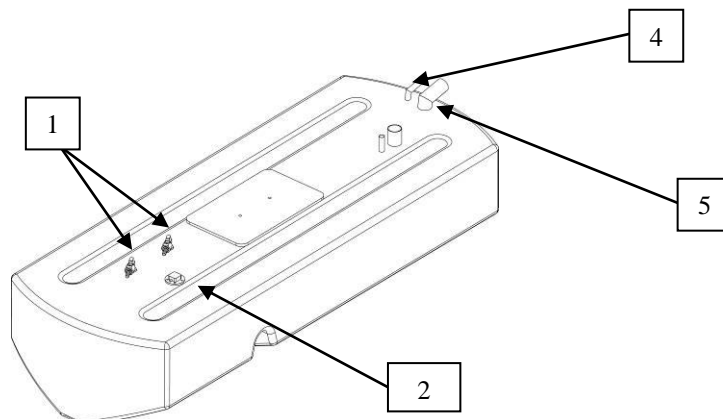



## INSTALLATION AND CIRCUIT - Fuel

### IV-1-3- Water/Fuel separator filter

<b>NOTE:</b>	<b>To protect the engine, a water/fuel separator filter is placed on the fuel supply circuit.</b>
--------------	---

The water/fuel separator filter is located in the aft chest, on the starboard partition (contact your dealer to obtain a second filter for dual-engine configurations).



MARK	DESIGNATION
1	Filter head, fixed to the boat
2	Interchangeable filtering element

 <b>WARNING</b>	<b>THE CARTRIDGE MUST BE CHANGED EVERY 50 HOURS USE</b>
---	---

# INSTALLATION AND CIRCUIT - Fuel

## Changing the filter cartridge:

Comply with Zodiac recommendations and filter manufacturer recommendations

Place a funnel and recovery bowl underneath the cartridge while it is being replaced. Before changing the filter, make sure the fuel supply line pressure is released. Please refer to the engine manufacturer's owner manual instructions.

Gasoline is a highly flammable product. **TURN THE ENGINE OFF**, disconnect the battery, do not smoke and keep all naked flames well away while you proceed with the kit installation. Place a funnel and bowl pan underneath the cartridge while it is being replaced.

Before changing the filter, make sure the fuel supply line pressure is released.



## IV-1-4-Using the fuel circuit cut-off valves:

<b>NOTE:</b>	<ul style="list-style-type: none"> <li>- When you are no longer using your boat, close the fuel circuit valve</li> <li>- When you are going to use your boat, open the fuel circuit valve</li> </ul>
--------------	--

Fuel circuit valve  
Open position

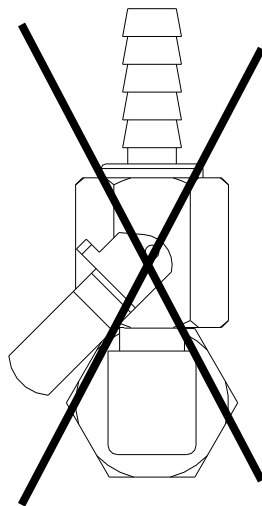
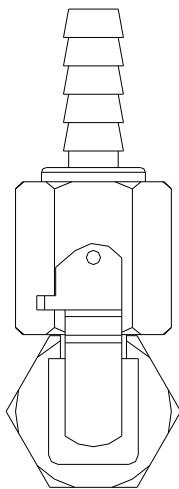



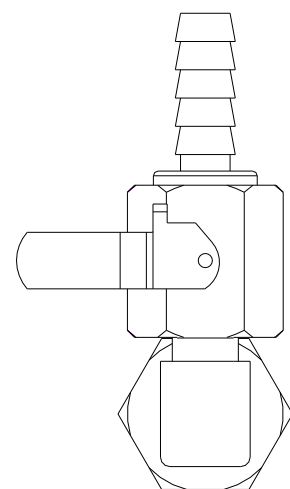

Fuel circuit valve  
Closed position



## INSTALLATION AND CIRCUIT - Fuel

### IV-1-5-Recommendations:

 <b>WARNING</b>	<p><b>IN CASE OF FUEL LEAK OR FIRE, THE FUEL CIRCUIT CLOSING VALVE, LOCATED ON THE TANK, ISOLATES THE TANK FROM THE FUEL CIRCUIT AND MUST REMAIN CLOSED.</b></p>
 <b>WARNING</b>	<ul style="list-style-type: none"> <li><input checked="" type="checkbox"/> <b>A FULL TANK AVOIDS CONDENSATION ON EACH OPERATION.</b></li> <li><input checked="" type="checkbox"/> <b>CLEAN THE TANK EVERY FIVE YEARS.</b></li> <li><input checked="" type="checkbox"/> <b>CHECK THAT THE CLAMPS ON ALL HOSES ARE CORRECTLY TIGHTENED.</b></li> <li><input checked="" type="checkbox"/> <b>WHEN PURGING THE FILTER, DO NOT DUMP THE WATER IN THE BOAT. USE A RECOVERY TRAY BELOW THE FILTER.</b></li> <li><input checked="" type="checkbox"/> <b>CUT THE POWER SUPPLY BEFORE DISMANTLING THE FILTER CARTRIDGE</b></li> <li><input checked="" type="checkbox"/> <b>READ THE INSTRUCTIONS ON THE FILTER MANUAL ATTENTIVELY.</b></li> </ul>
 <b>WARNING</b>	<ul style="list-style-type: none"> <li><input checked="" type="checkbox"/> <b>FUEL IS EXTREMELY FLAMMABLE. WHEN WORKING ON THE FUEL SYSTEM, MAKE SURE THE ENGINE IS CUT OFF.</b></li> </ul> <p><b>DO NOT SMOKE; KEEP FLAMES AND INCANDESCENT OBJECTS AWAY FROM THE WORKING AREA.</b></p>
 <b>WARNING</b>	<ul style="list-style-type: none"> <li><input checked="" type="checkbox"/> <b>NEVER DRILL THE TANK AREA WITH A BIT PROTRUDING MORE THAN 30 MM FROM THE DRILL HEAD (MARK ON THE DECK BY A HATCH) AND DO NOT USE SCREWS OVER 20 MM LONG.</b></li> </ul>

# INSTALLATION AND CIRCUIT - Electricity

## IV -2-ELECTRICITY

IV -2-1-Schematic diagram (an A3 drawing is supplied with the console connection unit).

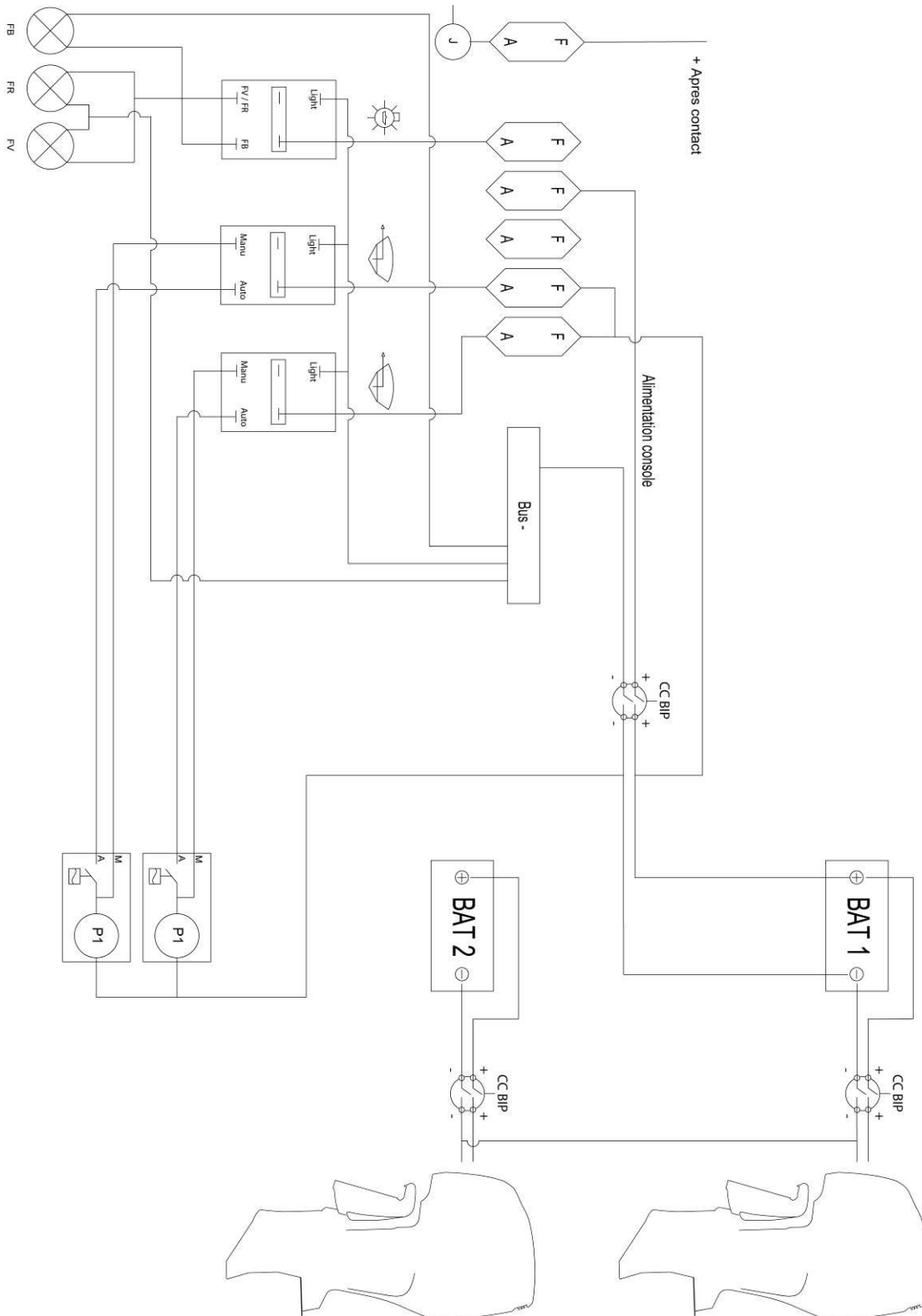

# INSTALLATION AND CIRCUIT - Electricity

## IV-2-2 - Harness drawings (an A3 drawing is supplied with the console connection unit).

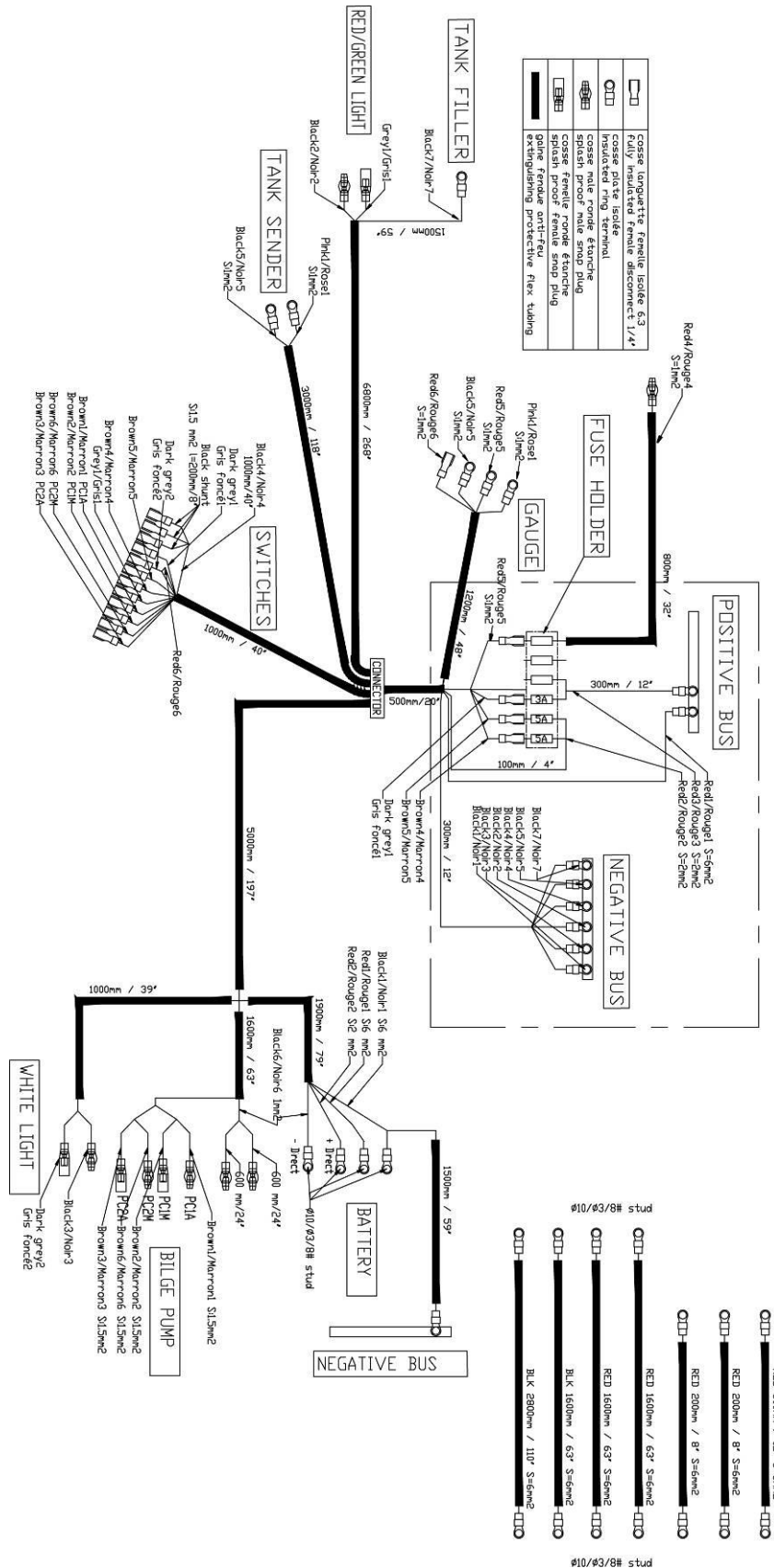

# INSTALLATION AND CIRCUIT - Electricity

## IV-2-3 Item location

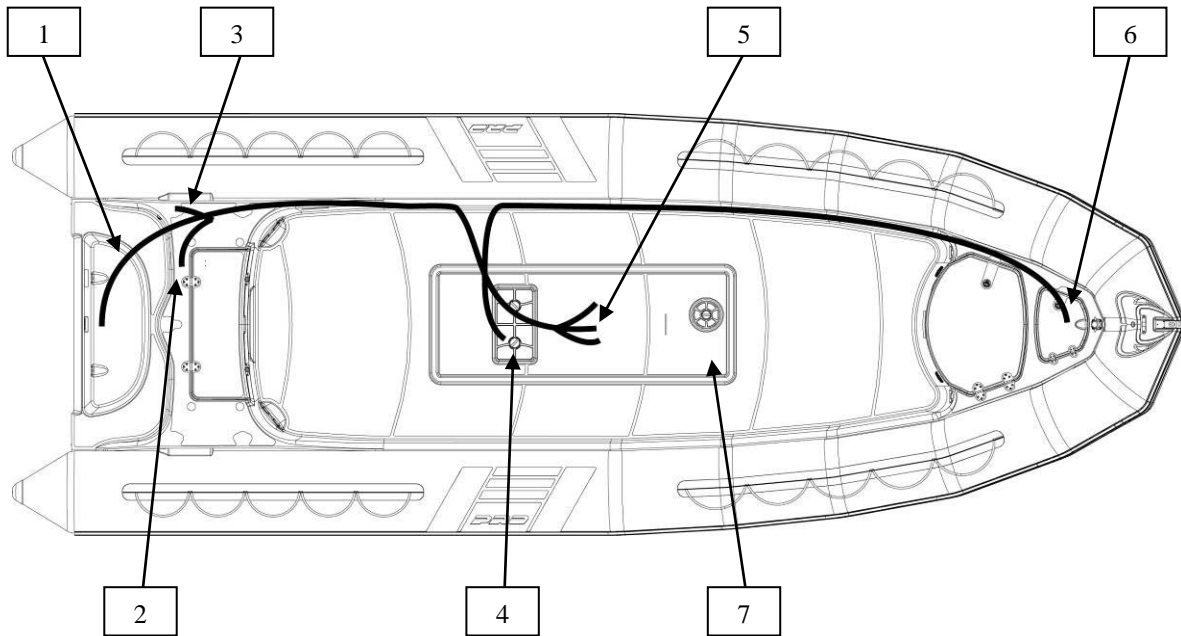

### Correspondence:

ITEM No.	DESIGNATION
1	Bilge pump switch
2	Coupler support and battery isolation switch
3	Standby power supply for white light
4	Reservoir gauge
5	Standby cable below the hatch for wiring to the console
6	Davit light power supply
7	Feedthrough position

## IV-2-4- Wiring the console unit and switch

Your boat has been prewired with an electrical harness; only some items remain to be connected to the console (the rest of the harness to connect to the console is below the bridge mark 5)

- 1 Box: distributor (bus bar + fuse holder)

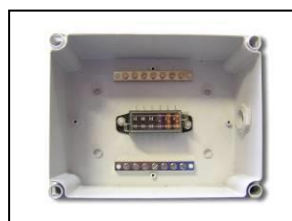

# INSTALLATION AND CIRCUIT - Electricity

- The light + bilge pump switches (also supplied).

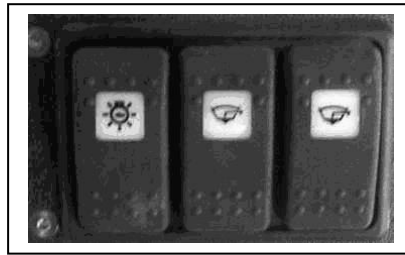

- The fuel gauge holder.

## IV-2-5 Wiring preparation

### IV-2-5-1 Installing the feedthrough (supplied)

 <p><b>WARNING</b></p>	<p><b>WHEN DRILLING, BE CAREFUL WITH THE TANK LOCATED JUST UNDERNEATH.</b></p>
---	--

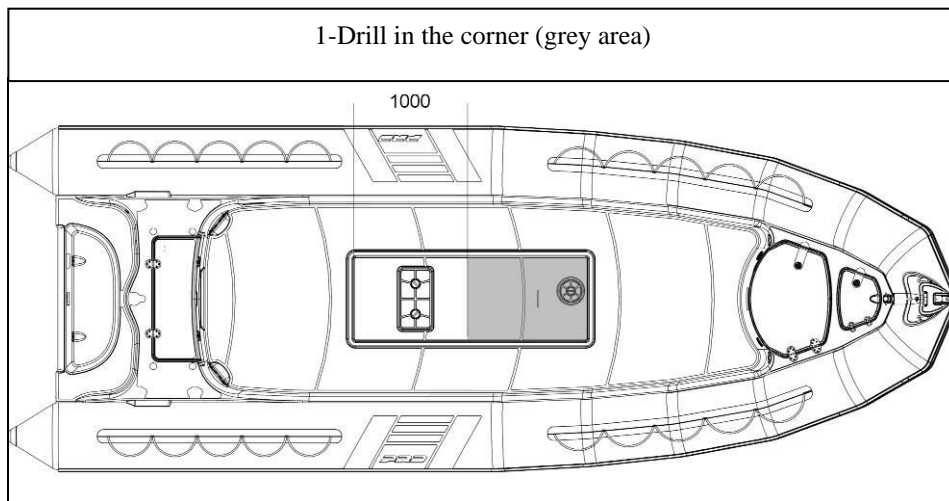

2- Find the electrical cables of the prewired harness. Mark 5

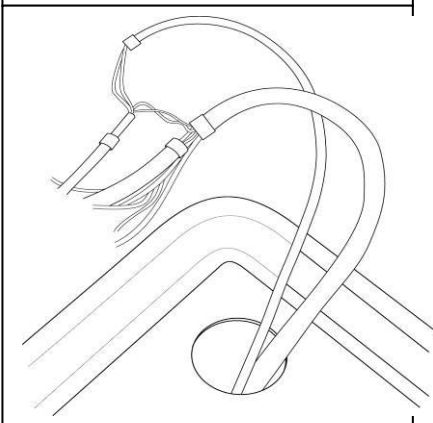

3- Present the clamp to pre-drill the deck, then drill.

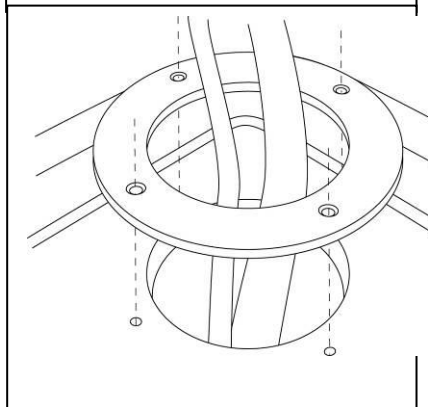

4 -Thread the feedthrough, the clamp and then attach everything to the deck. (Seal the screws and underside of the feedthrough)

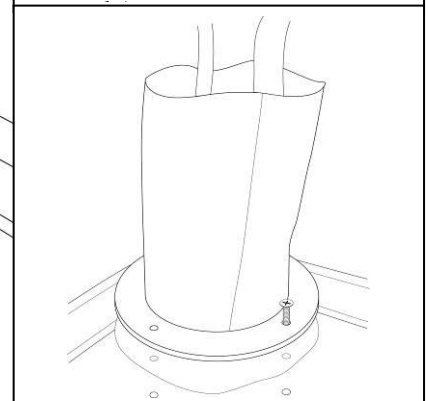

# INSTALLATION AND CIRCUIT - Electricity

## IV-2-5-2 Unit wiring

After positioning the console on the deck and passing the cables through the console shelf (for console Z61128), wire the unit.

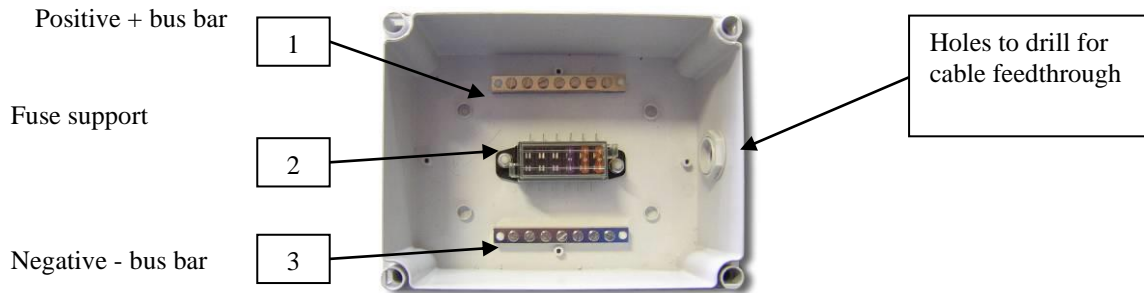

E  
N  
G  
L  
I  
S  
H

## IV-2-5-3 Wiring

- Step 1: Connect the following cables on the fuse support bus (mark 2).

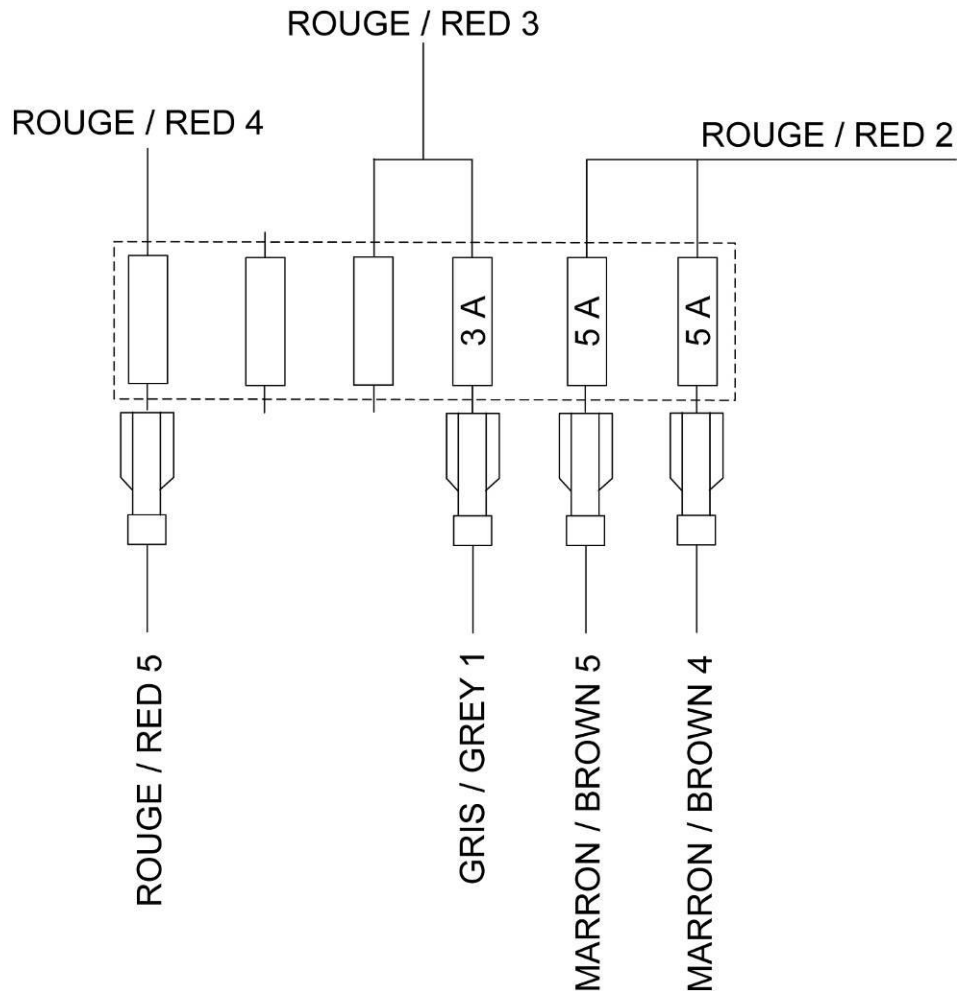



## INSTALLATION AND CIRCUIT - Electricity

- Step 2: Connect the following cables on the negative bus bar (mark 3).

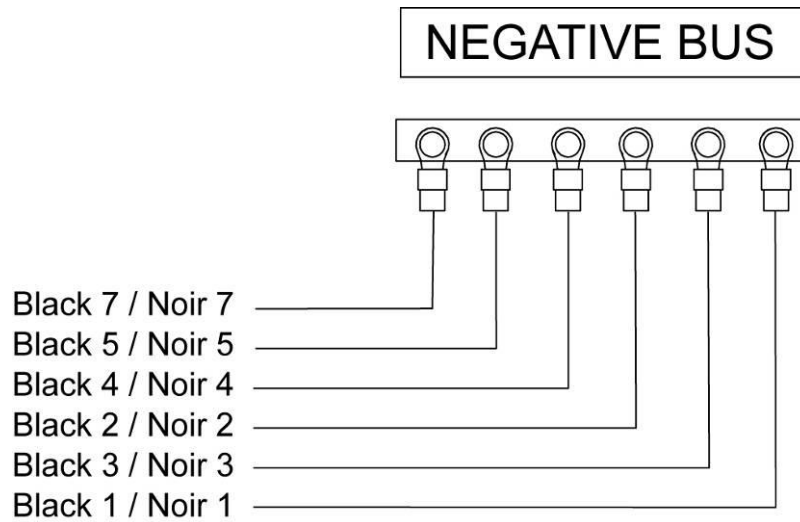

- Step 3: Connect the following cables on the positive bus bar (mark 1).

- Step 4: **Fix the unit to the console.**

Before attaching the unit to the side of the console, stick a piece of plywood on in order to increase the thickness to hold the screws.

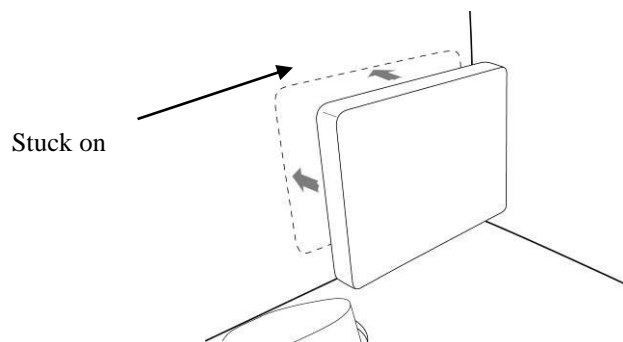

# INSTALLATION AND CIRCUIT - Electricity

Attach the unit onto the plywood using the wood screws (not supplied).

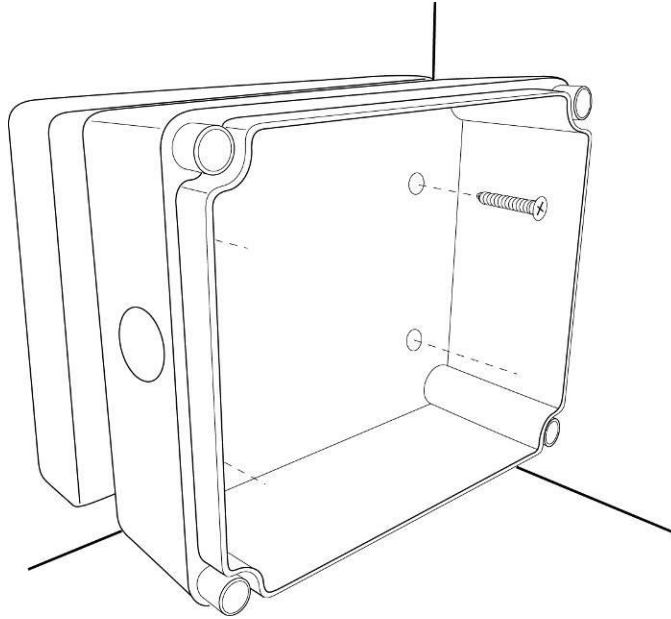

E  
N  
G  
L  
I  
S  
H

## IV-2-5-4 Switch wiring (bilge pumps + lights)

- Step 1: Position the switches on your console (taking the harness length into consideration).

If your boat has a Z61128 console, we recommend positioning the switch panel as shown below.

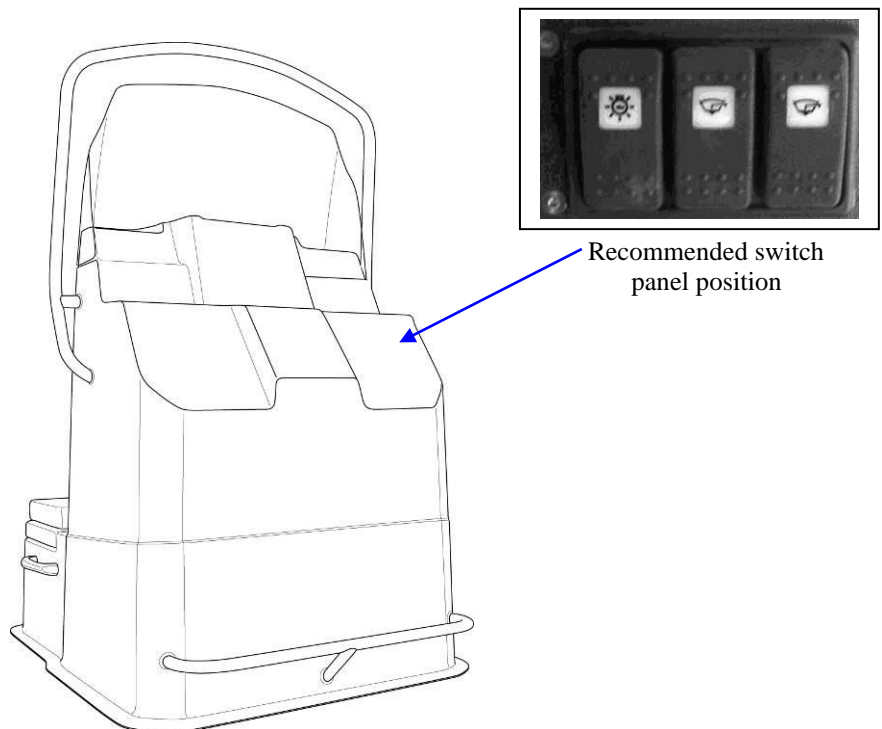

# INSTALLATION AND CIRCUIT - Electricity

- Step 2: Wiring

Group of wires to connect

Wiring seen from behind the switches

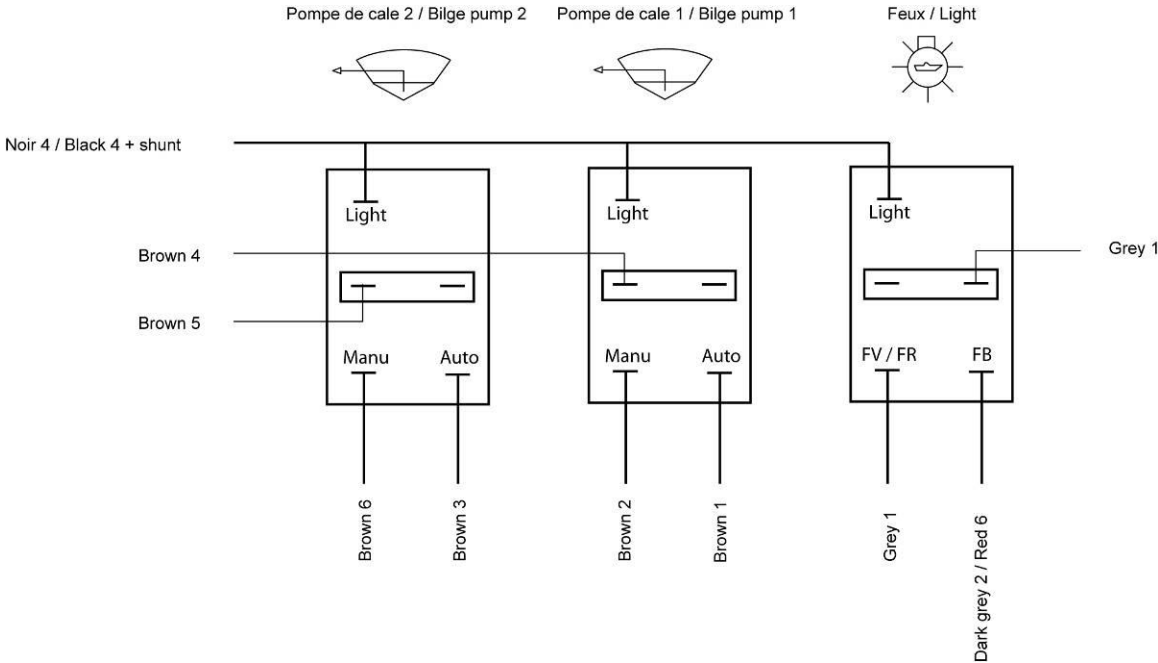

# INSTALLATION AND CIRCUIT - Electricity

## IV-2-5-5 Fuel gauge holder wiring (rear view)

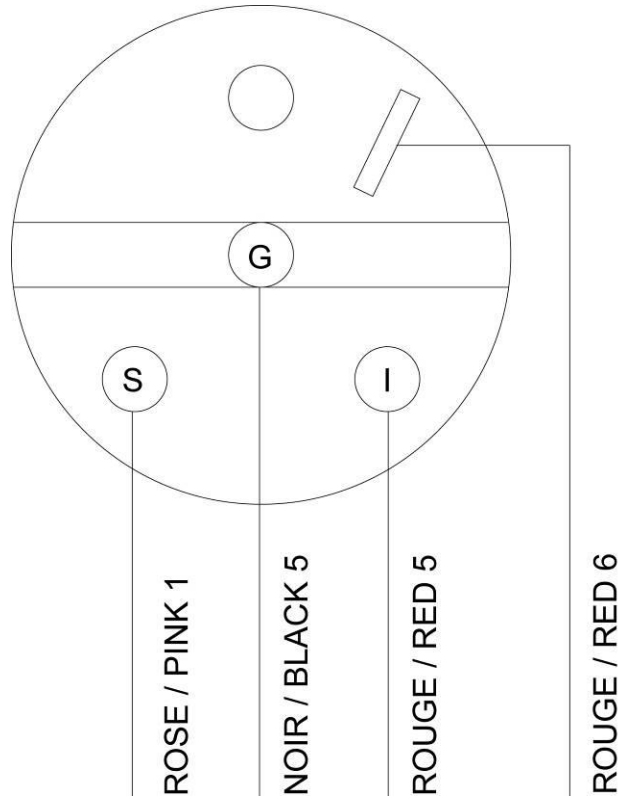

E  
N  
G  
L  
I  
S  
H

## IV-2-5-6 Circuit-breaker and battery isolation switch operation

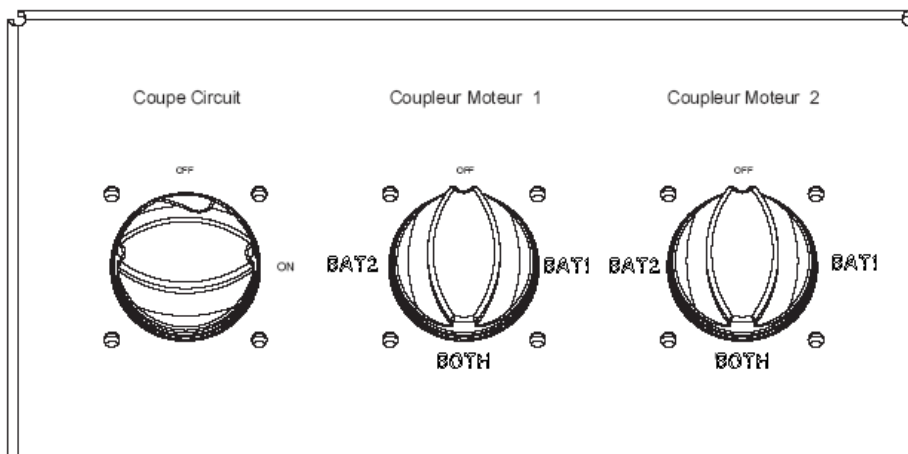

The boat is factory-mounted with a circuit breaker and two battery couplers (for dual-engine configuration).

For a single engine configuration, only one coupler will be used.

## INSTALLATION AND CIRCUIT

The circuit breaker isolates the console unit power supply.

<b>NOTE:</b>	After each use, set the circuit breaker back to OFF.
--------------	--

The battery couplers allow the engines to be started either with one battery per engine, or by coupling the batteries (in parallel), or with a single battery.

IV-2-5-7 Table of possible configurations

COUPLER STATE		RESULT
COUPLER 1 TO "OFF"	COUPLER 2 TO "OFF"	<i><b>THE ENGINES AND THE BATTERIES ARE ISOLATED</b></i>
COUPLER 1 TO "BAT 1"	COUPLER 2 TO "BAT 2"	<i><b>EACH ENGINE STARTS WITH ITS RESPECTIVE BATTERY. ALWAYS PUT THE COUPLERS IN THIS CONFIGURATION</b></i>
COUPLER 1 TO "BAT 1"	COUPLER 2 TO "BAT 1"	<i><b>BOTH ENGINES START WITH BATTERY 1 (used when battery 2 fails)</b></i>
COUPLER 1 TO "BAT 2"	COUPLER 2 TO "BAT 2"	<i><b>BOTH ENGINES START WITH BATTERY 2 (used when battery 1 fails)</b></i>
COUPLER 1 TO "BOTH"	COUPLER 2 TO "BOTH"	<i><b>BOTH ENGINES START COUPLING THE 2 BATTERIES</b></i>

# INSTALLATION AND CIRCUIT – Connecting the Options

## IV -2-6-CONNECTING THE OPTIONS

### IV -2-6-1-Precautions:

The boat is factory-mounted with 2 bilge pumps and navigation lights. Nevertheless, 2 spare positions remain in the fuse box (below the console) to connect additional accessories in some conditions:

- ① The accessories to add must be connected on the console.
- ② The accessories are divided into two categories:
  - A** → accessories used or that may be used continuously in normal boat operation,
  - B** → accessories only used intermittently.

A	and	B
Hold fan		Cigarette lighter
Radio		Miscellaneous lights
Depth-finder		Buzzer
GPS		Miscellaneous electronic equipment
Projector		Shower pump
Alarm system		Max. retained power
Fridge		60W maxi
VHF		
$\Sigma$		
	180 W max.	

 <b>WARNING</b>	<p><b>You must make sure that the total power consumed by all <u>added</u> column A accessories does not exceed 180 W (15 A) <u>AND</u> that the max. power of an accessory in column B does not exceed 60 W (5 A).</b></p> <p><b>The cross-sections of the bundle cables have been calculated for these values; non-compliance with this rule may cause electrical malfunction and short-circuiting.</b></p>
---	---

You may connect the options directly to the positive and negative console bus bars (within the max. power limits), using an approved fuse-holder.

# INSTALLATION AND CIRCUIT – Connecting the Options

**Example 1**

To add:

- a 72-W VHF,
- a 36-W GPS,
- a 60-W radio,
- a 72-W cigarette lighter,
- a 20-W clock.

A	
Hold fan	
Radio	60 W
Depth-finder	
GPS	36 W
Projector	
Alarm system	
Fridge	
VHF	72 W
$\Sigma$	168 W (< 180 W) ☺

and

B	
Miscellaneous lights	
Miscellaneous electronic equipment	20 W (clock)
Shower pump	
Max. retained power	60W ( $\leq$ 60W) ☺

CONCLUSION	☺
------------	---

**Example 2**

To add:

- a 60-W VHF,
- a 36-W GPS,
- a 48-W radio,
- a 120-W projector.

A	
Hold fan	
Radio	48 W
Depth-finder	
GPS	36 W
Projector	120 W
Alarm system	
Fridge	
VHF	60 W
$\Sigma$	264 W (> 180 W) ☹

and

B	
Miscellaneous lights	
Miscellaneous electronic equipment	
Shower pump	
Max. retained power	0 (< 60W) ☹

CONCLUSION	☹
------------	---

# INSTALLATION AND CIRCUIT – Connecting the Options

**Example 3**

To add:  
 a 60-W GPS,  
 a 60-W radio,  
 a 120-W buzzer.

A	
Hold fan	
Radio	60 W
Depth-finder	
GPS	60 W
Projector	
Alarm system	
Fridge	
VHF	
Σ	120 W (< 180 W) ↻

and

B	
Miscellaneous lights	
Miscellaneous electronic equipment	
Shower pump	
Max. retained power	120 W (> 60 W) ↻

CONCLUSION	
------------	--

<b>NOTE:</b>	<b>Some manufacturers indicate the intensity instead of the power consumed. For direct current (the case here), simply multiply by 12 to obtain the power and divide the power by 12 to obtain the intensity the device consumes.</b>
--------------	---

**IV -4-2-6-2Wiring:**

- ① Choose a free fuse position,
- ② Connect the accessory power supply to the position terminal with a 6-mm female tab,
- ③ If you must add a cable for connection, the minimum cross-section is 1.5 mm<sup>2</sup> and it must comply with "marine" cable recommendations (UL1426 or SAE J378 or SAE J1127 or SAE J1128 or, generally speaking, recommendations ABYC and/or CE),
- ④ Connect the accessory grounding cable to the grounding terminal with a dia. 5 ring lug (same remark as above for the cable),
- ⑤ Use an ATO type fuse, max. intensity 15 A and with a higher operating intensity that the accessory.





# INSTALLATION AND CIRCUIT – Connecting the Options

## IV -2-7-BILGE PUMP OPERATION

The bilge pump operation is independent from the battery switch position; the control switch  is always powered.

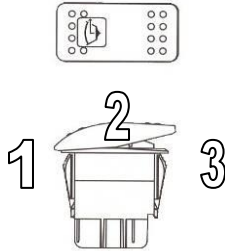
- ① Automatic ON (set position); in this position the bilge pump operates automatically. The indicator light is lit.
- ② OFF; in this position (set position), the bilge pump is shut down. The indicator light is not lit.
- ③ Forced ON; the switch must be held for forced operation. As soon as you release the switch, it returns to OFF (2).





 <b>WARNING</b>	<p style="text-align: center;"><b>WHEN MOORED, SET THE BILGE PUMP SWITCH TO AUTOMATIC.</b></p>
<p><b>NOTE:</b></p>	<p style="text-align: center;"><b>ZODIAC RECOMMENDS USING A TARPAULIN OR COCKPIT COVER TO PREVENT RAINWATER FROM COMING IN.</b></p>

# INSTALLATION AND CIRCUIT - Electricity

## IV-2-8- Battery (not supplied)

Comply with ZODIAC recommendations and battery manufacturer recommendations for everyday maintenance.

	<p>Battery care:</p> <ul style="list-style-type: none"> <li><input checked="" type="checkbox"/> Keep the battery clean and dry to avoid premature wear</li> <li><input checked="" type="checkbox"/> Tighten and maintain the terminal lugs coating them regularly with Vaseline</li> </ul>
---	--

 <b>CAUTION</b>	<p><b>WATER FROM THE WATER COLLECTION SYSTEM CONTAINS MINERALS THAT DAMAGE THE BATTERIES. CONSEQUENTLY ALWAYS TOP UP WITH DISTILLED WATER.</b></p>
 <b>WARNING</b>	<ul style="list-style-type: none"> <li>• <b>KEEP BATTERIES AND BATTERY ACID OUT OF THE REACH OF CHILDREN</b></li> <li>• <b>ALWAYS KEEP BATTERIES UPRIGHT</b></li> <li>• <b>WHEN ADDING BATTERY ACID OR RECHARGING THE BATTERY, ALWAYS REMOVE IT FROM THE ENGINE COMPARTMENT</b></li> <li>• <b>BATTERY ACID IS A TOXIC AND DANGEROUS SUBSTANCE IT CONTAINS SULPHURIC ACID THAT CAN CAUSE SERIOUS BURNS AVOID CONTACT WITH THE SKIN, EYES AND CLOTHING</b></li> <li>• <b>BATTERIES MAY GIVE OFF EXPLOSIVE GASES REMOVE ALL SOURCES OF SPARKS, NAKED FLAMES, CIGARETTES, ETC.</b></li> <li>• <b>ONLY CHARGE OR USE A BATTERY IN A WELL AIRED PLACE. ALWAYS PROTECT YOUR EYES WHEN WORKING CLOSE TO A BATTERY.</b></li> </ul>

<p><b>NOTE:</b></p>	<ul style="list-style-type: none"> <li><input checked="" type="checkbox"/> If you do not plan to use your Zodiac® for a month or more, remove the battery and store it in a cool, dark and dry place. Completely recharge the battery before reusing it.</li> <li><input checked="" type="checkbox"/> If the battery is to be put away for a long period, check the density of the battery acid at least once a month and recharge the battery when the density is too low.  <b>Battery acid density: 1.28 at 20 °C</b></li> </ul>
---------------------	--

<p><b>NOTE:</b></p>	<p><b>When you stop using the boat, set the circuit-breaker to OFF.</b></p>
---------------------	---

# INSTALLATION AND CIRCUIT - Drainage

## IV -3-DRAINAGE:

### IV -3-1-Description of essential functional parts:

The boat empties itself, it has 4 quick drain holes at the rear of the deck.

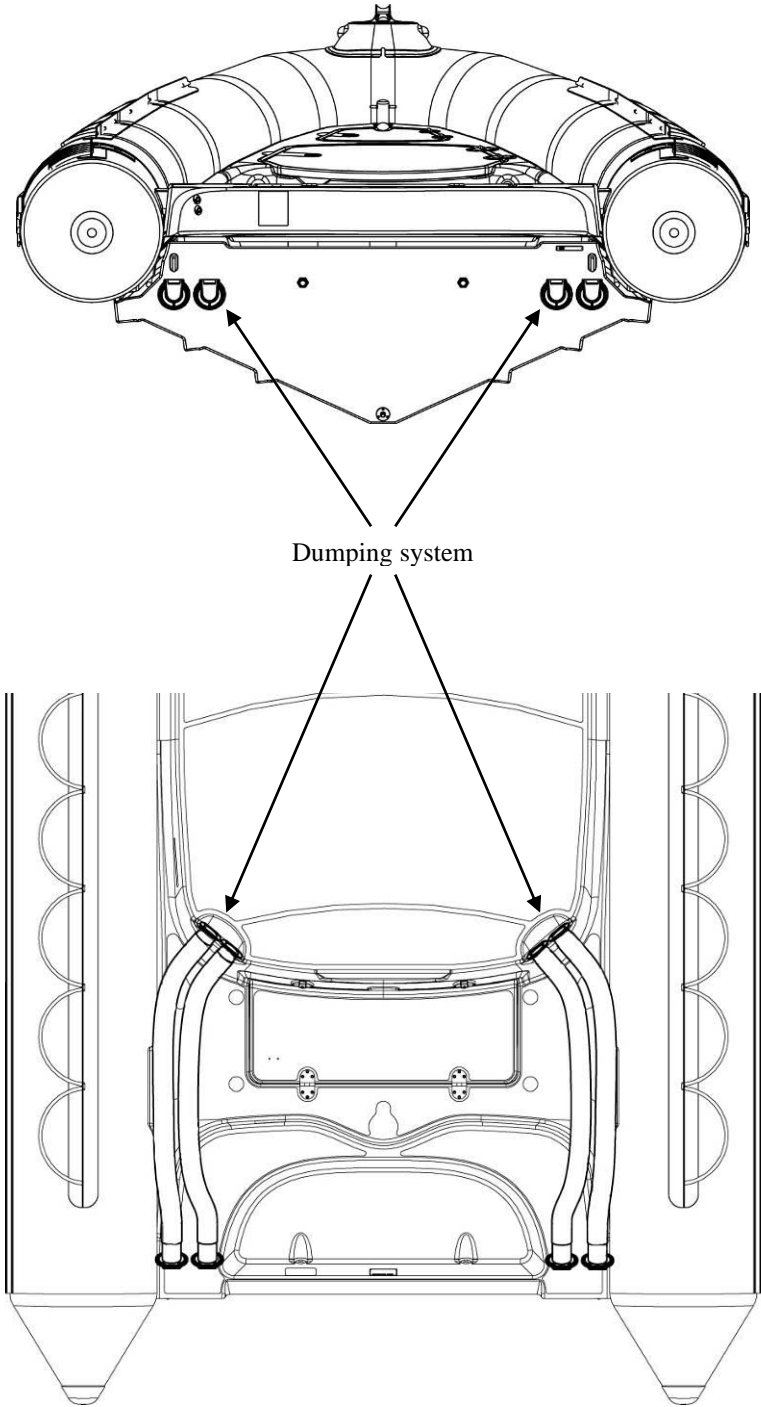

# INSTALLATION AND CIRCUIT - Drainage

## IV-3-2-Hull plug hole

### IV-3-2-1-Boat outside the water (on trailer, cradle, etc.)

	<b>POSITION OPEN, PLUG REMOVED.</b>
---	-------------------------------------

### IV-3-2-2-Boat in the water

	<b>POSITION CLOSED, PLUG(S) IN POSITION. (MAKE SURE THE PLUG IS PROPERLY CLOSED.)</b>
---	---

ENGLISH

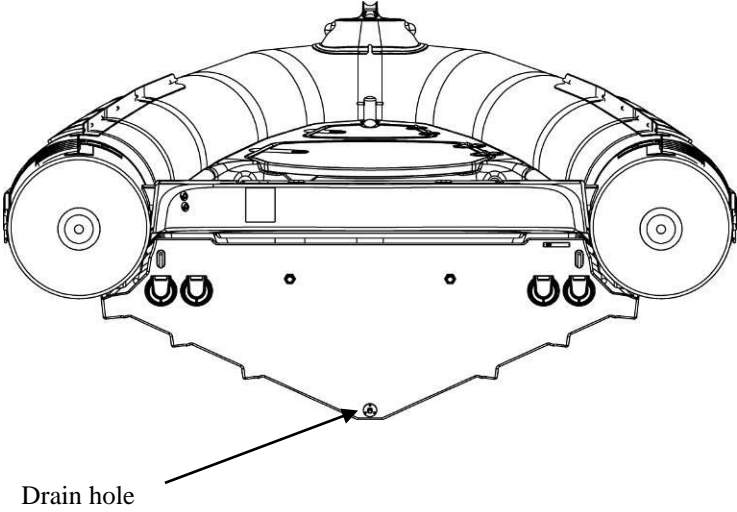

## **INSTALLATION AND CIRCUIT - Steering**

### **IV-4-STEERING**

A hydraulic jack (optional) may be used for the single-engine configuration and in some cases for the dual-engine (see max. authorized power).

Comply with the steering manufacturer's recommendations (installation, use and maintenance).

For optimum use of your boat, see your dealer.

## **INSTALLATION AND CIRCUIT - Fire**

### **IV-5- FIRE**



**WE RECOMMEND YOU KEEP AN EXTINGUISHER ON BOARD. COMPLY WITH THE LAWS APPLICABLE IN YOUR COUNTRY.**

# INSTALLATION AND CIRCUIT - Anchoring/Mooring

**IV-6- ANCHORING/MOORING**

**IV -6-1-Description of essential functional parts:**

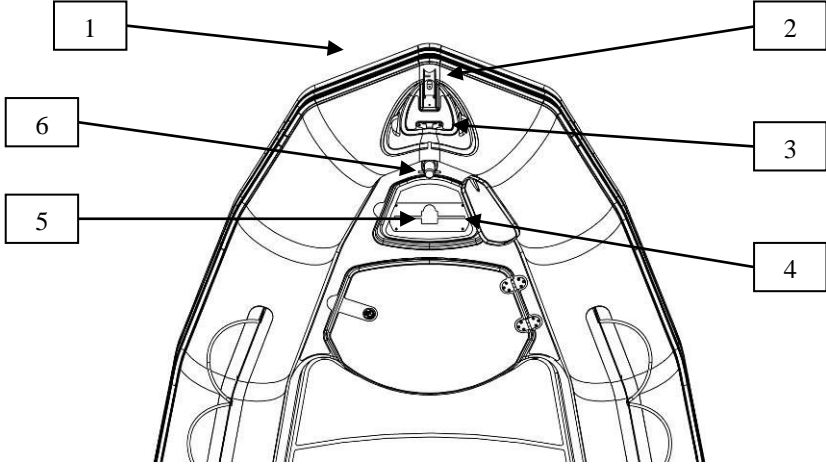

E  
N  
G  
L  
I  
S  
H

MARK	DESIGNATION
1	Chain plate
2	Roller chock + rea
3	Fairlead
4	Anchoring chest
5	Anchor support plate
6	Mooring cleat

**IV-6-2- Use**

 <b>WARNING</b>	<p><b>THE FAIRLEAD AND CLEATS CAN ONLY BE USED FOR OCCASIONAL MOORING OF THE BOAT. FOR PERMANENT MOORING, USE THE BOW CHAIN PLATE PROVIDED AT THE FRONT OF THE BOAT.</b></p>
---	--

# INFORMATION AND IDENTIFICATION PLATES

## V-1-SAFETY LABEL AND REGISTRATION PLATES POSITION

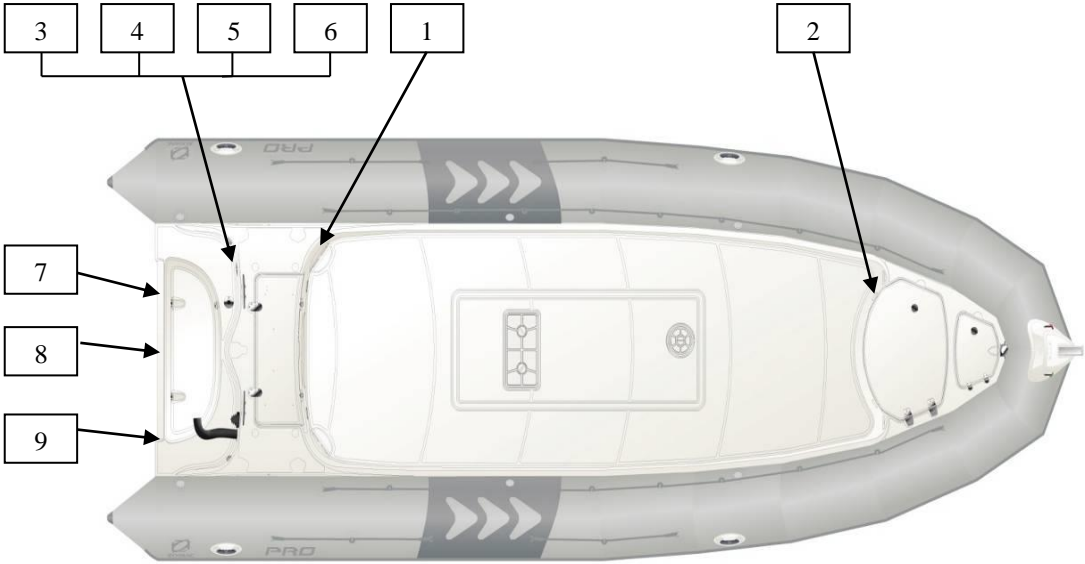

# INFORMATION AND IDENTIFICATION PLATES

## V -2-SAFETY LABEL AND REGISTRATION PLATES DESCRIPTION

	<b>⚠ WARNING</b>	<b>⚠ AVERTISSEMENTS</b>	1
	<ul style="list-style-type: none"> <li>DO NOT TOUCH BATTERY TERMINALS (SHOCK AND ACID HAZARDS)</li> <li>DISCONNECT BOTH LEADS BEFORE REMOVING BATTERY</li> <li>CONNECT RED LEAD TO POSITIVE (+) TERMINAL</li> <li>CONNECT BLACK LEAD TO NEGATIVE (-) TERMINAL</li> </ul>	<ul style="list-style-type: none"> <li>NE PAS TOUCHER LES TERMINAUX DE LA BATTERIE (RISQUE DE CHOC ELECTRIQUE ET DE CONTACT AVEC L' ACIDE DE LA BATTERIE)</li> <li>DEBRANCHER LES 2 FILS DE SORTIE AVANT DE RETIRER LA BATTERIE</li> <li>RELIER LE CABLE ROUGE A LA BORNE (+)</li> <li>RELIER LE CABLE NOIR A LA BORNE (-)</li> </ul>	

	<b>⚠ WARNING</b>	<b>⚠ AVERTISSEMENTS</b>	2
	<p style="text-align: center; margin: 0;"><b>GASOLINE IS HIGHLY INFLAMMABLE AND EXPLOSIVE</b></p> <ul style="list-style-type: none"> <li>STOP ENGINE BEFORE REFUELING</li> <li>REFUEL IN WELL VENTILATED AREA</li> <li>NEVER REFUEL WHILE SMOKING, AROUND SPARKS OR OPEN FLAME</li> <li>AVOID SPILLING FUEL. WIPE UP ALL FUEL SPILLS IMMEDIATELY</li> <li>LEAKING FUEL IS A FIRE HAZARD AND EXPLOSION HAZARD</li> <li>INSPECT FUEL SYSTEM BEFORE EACH USE</li> </ul>	<p style="text-align: center; margin: 0;"><b>L' ESSENCE EST TRES FORTEMENT INFLAMMABLE ET EXPLOSIVE</b></p> <ul style="list-style-type: none"> <li>ARRETER LE MOTEUR AVANT TOUT REMPLISSAGE.</li> <li>NE PAS FUMER LORS DU REMPLISSAGE.</li> <li>FAIRE LE PLEIN DANS UN ENDROIT VENTILE.</li> <li>EVITER DE RENVERSER DU CARBURANT. ESSUYER IMMEDIATEMENT TOUTES LES FLAQUES DE CARBURANT CREEES</li> <li>LES FUITES DE CARBURANTS CONSTITUENT UN RISQUE D' INCENDIE ET D' EXPLOSION</li> <li>VERIFIER LE CIRCUIT CARBURANT AVANT CHAQUE UTILISATION</li> </ul>	

<b>⚠ CAUTION</b>	<b>⚠ ATTENTION</b>	3
<p style="text-align: center; margin: 0;"><b>IMPROPERLY TOWING YOUR BOAT CAN CAUSE SEVERE DAMAGE TO YOUR BOAT.</b></p> <ul style="list-style-type: none"> <li>NEVER TOW IN OPEN SEAS</li> <li>NEVER TOW ABOVE 6 KNOTS</li> </ul>	<p style="text-align: center; margin: 0;"><b>UN REMORQUAGE INAPROPRIE PEUT ENDOMMAGER VOTRE BATEAU</b></p> <ul style="list-style-type: none"> <li>NE PAS REMORQUER EN PLEINE MER</li> <li>NE PAS REMORQUER A PLUS DE 6 NOEUDS</li> </ul>	

<b>⚠ WARNING</b>	<b>⚠ AVERTISSEMENT</b>	4
<p><b>DO NOT LIFT THE BOAT WITH PASSENGERS ON BOARD</b></p>	<p><b>NE PAS SOULEVER LE BATEAU AVEC DES PASSAGERS A BORD</b></p>	



# INFORMATION AND IDENTIFICATION PLATES

<p style="font-size: 24px; margin: 0;"><b>⚠ DANGER</b></p> <p>TO AVOID INJURY OR DEATH, SHUT OFF ENGINE WHEN NEAR SWIMMERS OR PRIOR TO USING SWIN PLATFORM AND BOARDING LADDER</p>	<p style="font-size: 24px; margin: 0;"><b>⚠ DANGER</b></p> <p>POUR EVITER DES BLESSURES OU LA MORT, COUPER LE MOTEUR EN APPROCHANT DE NAGEURS, ET AVANT TOUTE UTILISATION DE LA PLATEFORME ARRIERE OU DE L' ECHELLE DE BAIN</p>
--	---

5

<p style="font-size: 24px; margin: 0;"><b>⚠ DANGER</b></p> <p>A FIRE EXTINGUISHER MUST BE CARRIED AT ALL TIMES</p>	<p style="font-size: 24px; margin: 0;"><b>⚠ DANGER</b></p> <p>UN EXTINCTEUR DOIT ETRE DISPONIBLE EN PERMANENCE A BORD</p>
--	---

6

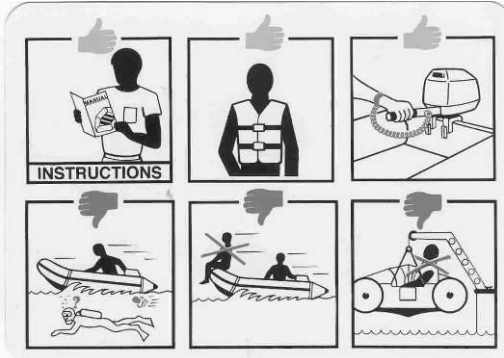

7

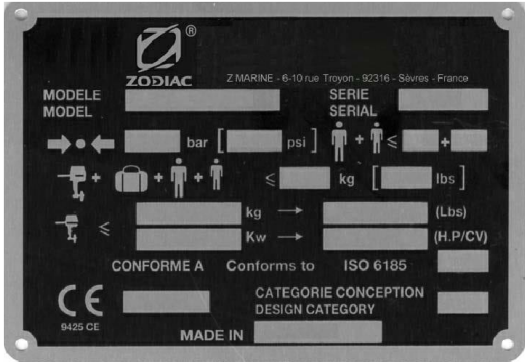

8

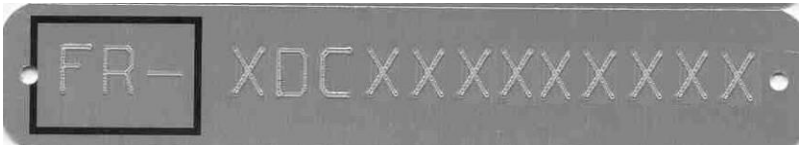

9

	<p style="text-align: center; font-weight: bold;">MAKE SURE THAT THE LABELS ARE PRESENT AND LEGIBLE. CONTACT YOUR DEALER TO OBTAIN NEW ONES IF NECESSARY.</p>
--	---

# LOCATION OF OPTIONAL ACCESSORIES

## VI -1 LOCATION OF CONSOLE Z61128 (For navigation category B or C)

Your boat may be fitted with an optional console (see your Zodiac dealer). To optimise the use of the boat and retain all accesses to deck wells (tank/electrical wiring and cable feedthrough accesses), we recommend placing the console in the area indicated below.

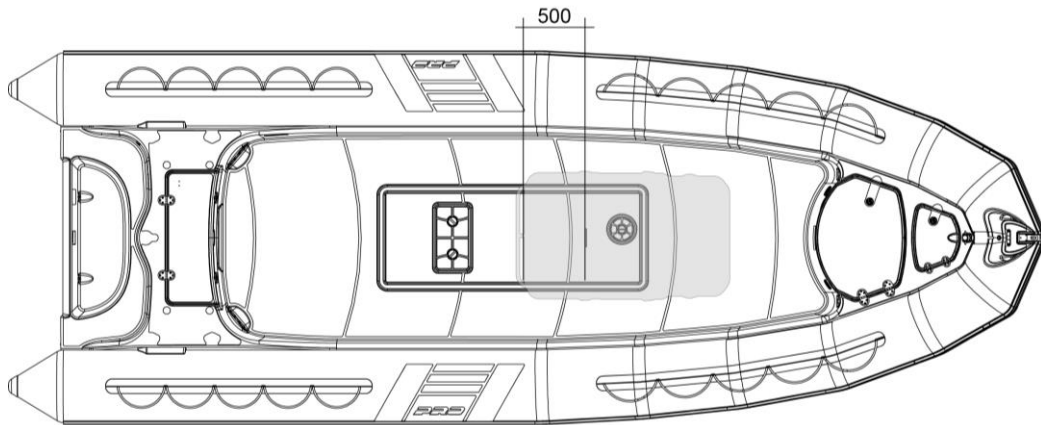

**WARNING**

**FEEDTHROUGH (NOT SUPPLIED) MUST ONLY BE PLACED IN THE GREY AREA SHOWN ABOVE.**

**E**

## VI-2 CABLE FEEDTHROUGH

Cables and fuel hoses are threaded below the boat deck (through factory pre-installed sleeves).

Cable exit on the deck (through a cable feedthrough)

Cable feedthrough area.

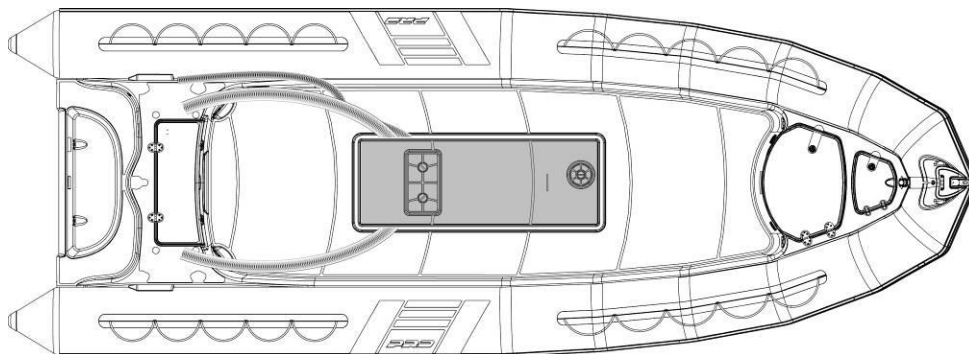
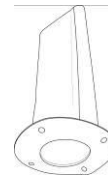

# LOCATION OF OPTIONAL ACCESSORIES

 <b>WARNING</b>	<p><b>FOR SAFETY REASONS, THE TANK HATCH MUST REMAIN ACCESSIBLE AND UNENCUMBERED BY THE POSITION OF ACCESSORIES. IT MAY HOWEVER BE ENTIRELY COVERED BY THE CONSOLE, WHILE REMAINING ACCESSIBLE THROUGH THE CONSOLE FRONT CHEST.</b></p>
---	---

 <b>CAUTION</b>	<p><b>NEVER DRILL THE TANK AREA WITH A BIT PROTRUDING MORE THAN 30MM FROM THE DRILL HEAD AND DO NOT USE SCREWS OVER 20 MM LONG.</b></p>
---	---

**VI-3 Position of accessories SEAT / BOLSTER (per design category)**

Depending on the navigation category in which the boat is used, the diagram below shows 2 positions for the seat or bolster depending on the number of seats required.

**VI-3-1 Category C**

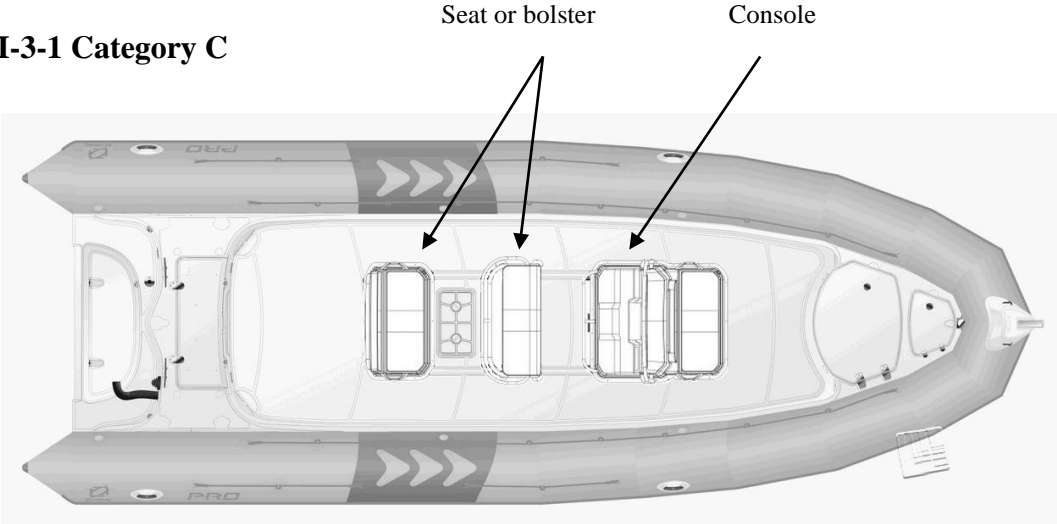

**VI-3-1 Category B. The number of persons in category B is limited to 10,**

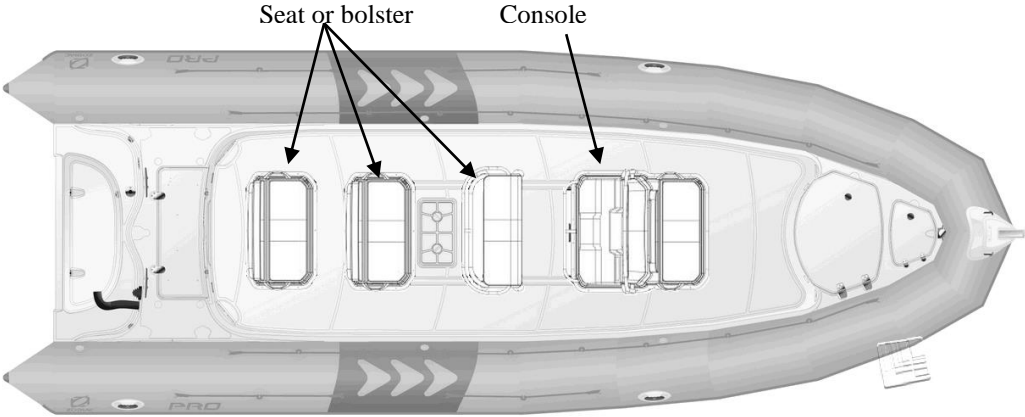

## LOCATION OF OPTIONAL ACCESSORIES

**VI-4-Position of ROLL BAR accessory (more detailed instructions are supplied with each option)**

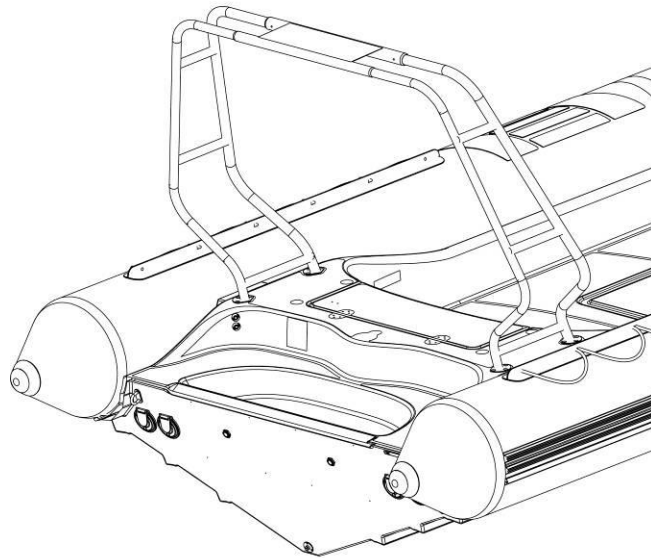

**VI-5-Position of accessory ski mast/ rear seatback**

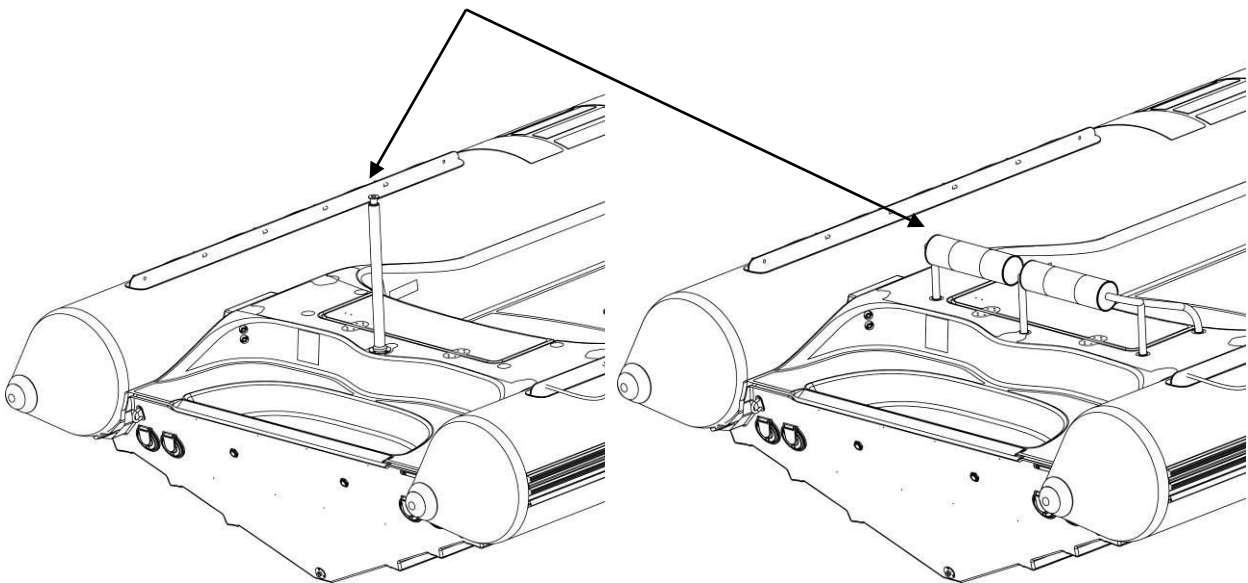



**THE SKI MAST CAN BE USED ONLY FOR SKI OR WAKEBOARD. FOR TOWING BOATS OR BUOY, USE REAR CHAIN PLATE**

## **LOCATION OF OPTIONAL ACCESSORIES**

**VI-1-6-Position of T-TOP accessory**

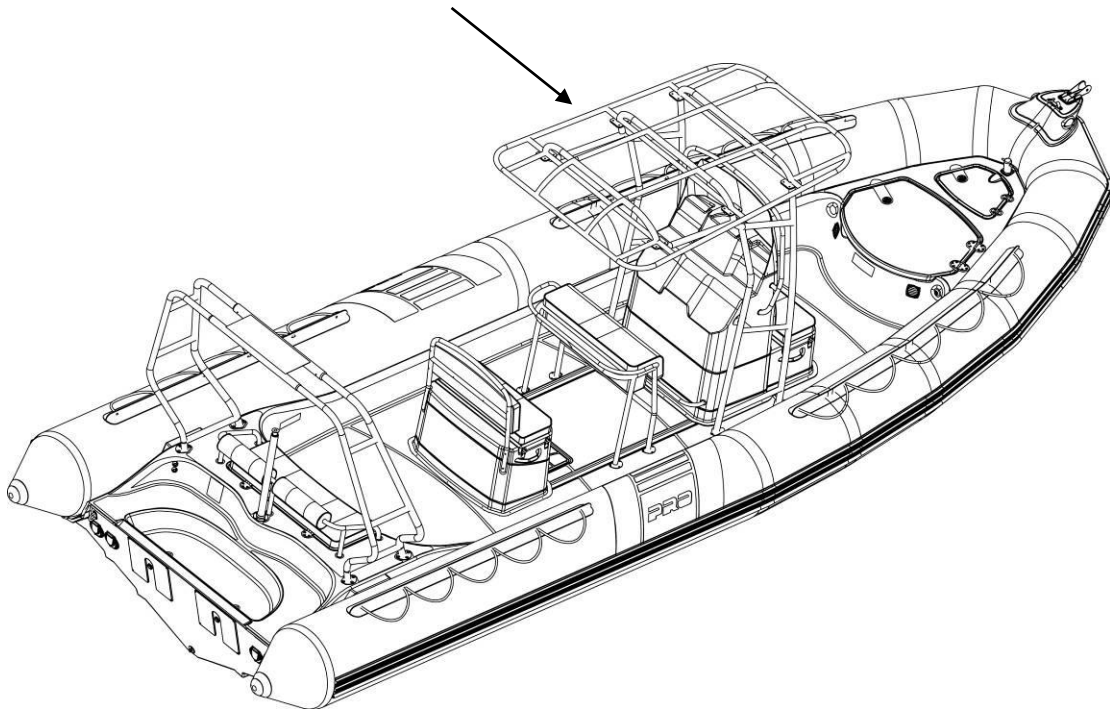





6-10 Rue Troyon  
92316- Sèvres - France

[www.zodiacmarine.com](http://www.zodiacmarine.com)

Pro 850

Code ZR20230

Edition 4



# **PRO**

## **PRO 850**

*Tome 2 – Volume 2*

*Teil 2 – Tomo 2*

7R20230

Edition 4



LIRE ATTENTIVEMENT CE MANUEL AVANT LA MISE EN SERVICE DE VOTRE ZODIAC.  
CAREFULLY READ THIS MANUAL BEFORE OPERATING YOUR ZODIAC.  
LEGGERE ATTENTAMENTE PRIMA DE INIZIARE IL MONTAGGIO DEL VOSTRO ZODIAC.  
VOR INBETRIEBNAHME IHRES ZODIAC VORLIEGENDES HANDBUCH AUFMERKSAM LESEN.  
LEER CUIDADOSAMENTE ESTE MANUAL ANTES DE PONER EN SERVICIO SU ZODIAC.





**Manual del Propietario  
Tomo 2**

**PRO 850**



**TOMO 2  
DESCRIPCIÓN - FLOTADOR  
SISTEMA DE PROPULSIÓN  
INSTALACIÓN Y CIRCUITOS**

# ÍNDICE

	PÁGINA
<b>⇒ I – DESCRIPCIONES GENERALES</b>	
<b>I-1-Características técnicas -----</b>	<b>3-6</b>
<b>I-2-Descripción técnica-----</b>	<b>6</b>
<b>I-3-Localización de los elementos-----</b>	<b>7-8</b>
<b>I-4-Manipulado-----</b>	<b>9</b>
<b>⇒ II – FLOTADOR</b>	
<b>II-1-Montaje del flotador en el casco-----</b>	<b>10</b>
<b>II-2-Fijación del faldón -----</b>	<b>11</b>
<b>II-3-Sistema de inflado-----</b>	<b>12-13</b>
<b>II-4-Presión -----</b>	<b>14-15</b>
<b>⇒ III - SISTEMA DE PROPULSIÓN</b>	<b>16</b>
<b>⇒ IV – INSTALACIONES Y CIRCUITOS</b>	
<b>IV-1-Combustible -----</b>	<b>17-20</b>
<b>IV-2-Electricidad -----</b>	<b>21-35</b>
<b>IV-3-Achique -----</b>	<b>36-37</b>
<b>IV-4-Dirección -----</b>	<b>37</b>
<b>IV-5-Incendio-----</b>	<b>38</b>
<b>IV-6-Fondeo/ Amarre-----</b>	<b>39</b>
<b>⇒ V – SEÑALIZACIÓN</b>	
<b>V-1-Posición de los adhesivos de seguridad y de las placas de matriculación-----</b>	<b>40</b>
<b>V-2-Descripción de los adhesivos de seguridad y de las placas de matriculación-----</b>	<b>41-42</b>
<b>⇒ VI – POSICIÓN / MONTAJE ACCESORIOS OPCIONALES</b>	
<b>VI-1-Posición consola -----</b>	<b>43-44</b>
<b>VI-2-Posición asiento / bolster -----</b>	<b>44</b>
<b>VI-3 Posición rollbar -----</b>	<b>45</b>
<b>VI-4 Posición mástil de esquí /respaldo posterior -----</b>	<b>45</b>
<b>VI-5 Posición TTOP -----</b>	<b>46</b>



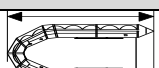
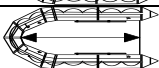

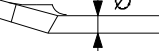
# DESCRIPCIÓN - Características Técnicas

## I-1-CARACTERÍSTICAS TÉCNICAS

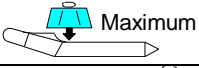
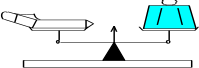
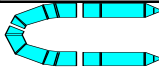
Dimensiones		
	(m)	8.5
	(ft)	27'10"
	(m)	7.45
	(ft)	24'5"
	(m)	3
	(ft)	9'10"
	(m)	1.85
	(ft)	6'
	(m)	0.6
	(ft)	1'11"

Categoría de concepción	
 (Directiva 94/25/CE)	B / C

Capacidad			
 (ISO)		B=10	C=20
 Maximum	kg <sup>(1)</sup>	2050	2800
	lbs <sup>(1)</sup>	4519	6173
	kg <sup>(2)</sup>	1350	1350
	lbs <sup>(2)</sup>	2976	2976
 Compartimentos		7	

Motor				
Longitud del eje			MONOMOTOR	BIMOTOR
			XXL	XL
	Potencia MÍNIMA aconsejada	CV <sup>(3)</sup>	250	2*175
		Kw <sup>(3)</sup>	187	2*131
	Potencia MÁXIMA aconsejada	CV	300	2*225
		kW	225	2*166
	Potencia MÁXIMA autorizada	CV <sup>(3)</sup>	300	2*225
		kW <sup>(3)</sup>	225	2*166
 Maximum	Peso MÁXIMO motor	kg	393	2*272
		lbs	866	2*600

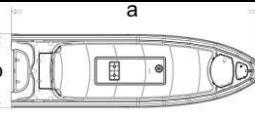
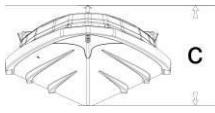
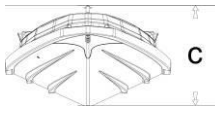
Dimensiones del casco (sin opciones)		
 a	a <sup>(4)</sup> (m)	7,78
	(ft)	25'6"
 b	b <sup>(4)</sup> (m)	2,27
	(ft)	7'5"
 c	c <sup>(4)</sup> (m)	1,37
	(ft)	4'5"

E  
S  
P  
A  
Ñ  
O  
L

## DESCRIPCIÓN - Características técnicas

**Categoría de concepción :** Su embarcación se ha diseñado para navegar en categoría B o C, lo que implica cargas y accesorios diferentes. (ver tabla anterior).

Respecto a la categoría B, el máximo de personas autorizadas es de 10 y la disposición de la cubierta debe permitir a todos los pasajeros permanecer sentados y poderse sujetar. Para ello, le aconsejamos utilizar los accesorios T4 previstos para este efecto. (contacte con su distribuidor)

**Posicion de los accesorios ASIENTO T4 / BOLSTER T4. (Depiende de la categoria de concepcion)**

**VI-1-3-1-categoría C.**

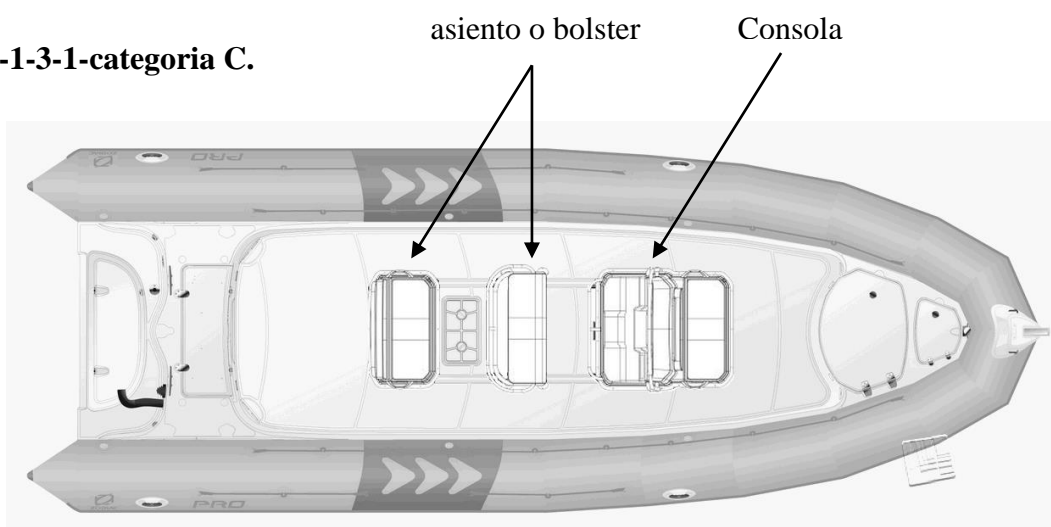

**VI-1-3-1-categoría B. El nombre de pasajeros esta limitado a 10 personas por este categoria.**

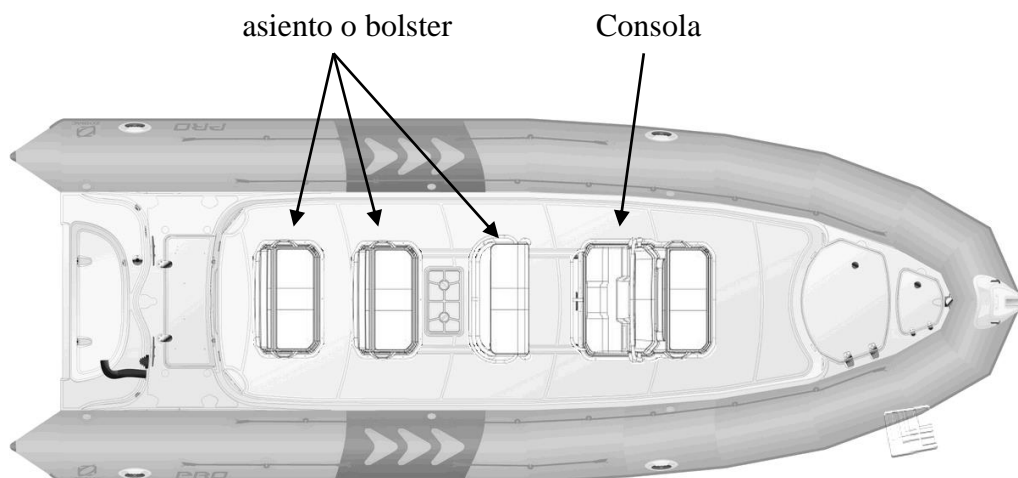





## DESCRIPCIÓN - Características técnicas

NOTA	Tolerancia en las dimensiones: +/- 4 % Tolerancia en los pesos: +/- 5%
------	---

NOTA	<p>(1) La carga máxima autorizada se ha calculado según la norma ISO 6185. Se aconseja navegar con precaución cuando la embarcación esté cargada al máximo.</p> <p>(2) Pesos indicados sin accesorios</p> <p>(3) Las potencias aconsejadas corresponden a una explotación óptima de las capacidades de la embarcación para una carga media.</p> <p>(4) Dimensiones del casco sin flotador.</p> <p>Utilice la potencia máxima autorizada con extrema prudencia (ver Tomo 1 del manual, capítulo "Consejos de navegación").</p>
------	---

 ATENCIÓN	<b>NO SE DEBE SOBREPASAR LA CARGA MÁXIMA INDICADA EN LA PLACA DEL FABRICANTE. LA CARGA MÁXIMA COMPRENDE EL/LOS MOTOR/ES, EL COMBUSTIBLE, LOS ACCESORIOS, LOS PASAJEROS Y SU EQUIPAMIENTO Y CUALQUIER OTRO TIPO DE CARGA.</b>
--	--

 ATENCIÓN	<b>NO ALMACENAR PRODUCTOS INFLAMABLES EN EL COMPARTIMENTO DE POPA. ESTÁ PROHIBIDO ALMACENAR UN DEPÓSITO AUXILIAR.</b>
---	---

## FLOTADOR - LIMPIEZA

El flotador de su embarcación es de tejido Hypalon™ Néoprène™ 1670 dtex.

Para una limpieza óptima, aconsejamos limpiar el flotador con agua jabonosa o con productos ecológicos, tipo Revival, disponible en su distribuidor.

 ATENCIÓN	<b>NO UTILIZAR PRODUCTOS DE LIMPIEZA AGRESIVOS CON DISOLVENTES COMO EL ACETATO</b>
---	--

# DESCRIPCIÓN TÉCNICA

## I -2-INVENTARIO

CASCO
• Casco de poliéster
• Cubierta antideslizante
• 1 anilla de arrastre
• 1 Cofre de ancla
• 1 pasteca de amarre
• 1 bita de amarre
• 1 tambucho de proa + recipiente extraíble (75 litros)
• 1 tambucho de popa
• 2 anillas de arrastre
• 1 desagüe de casco
• 4 desagües de gran caudal
• 1 depósito de 400 litros
• 1 filtro separador agua / carburante
• 1 registro de acceso a válvulas / aforador del circuito de combustible
• 1 registro de acceso a conexiones de tubos de combustible
• Circuito eléctrico con conectadores de baterías y desconectador
• 2 bombas de achique
FLOTADOR
• Flotador extraíble de tejido STRONGAN DUOTEX 2 X 1100 Decitex
• 7 Válvulas semi-encastradas “easy-push”
• Perfil defensa ultra ancho
• 4 asas exteriores
• 2 parches
• cabos
• Conos cortos
• 1 púlpito de proa + roldana + cornamusa + luces
EQUIPAMIENTO ESTÁNDAR
• 2 pagayas
• Inflador de pie
• Manómetro
• Maletín de reparaciones
ACCESORIOS OPCIONALES*
• Consola T4
• Asiento T4
• Bolster
• Respaldo popa
• Mástil de esquí
• Roll-bar
• T Top
• Escalera de baño
• Soporte para botella de 4 y 6 botellas
• Inflador eléctrico.

\* Para más información sobre los accesorios opcionales disponibles, contacte con su distribuidor ZODIAC.

# DESCRIPCIÓN - Elementos funcionales

## I-3-LOCALIZACIÓN DE LOS ELEMENTOS

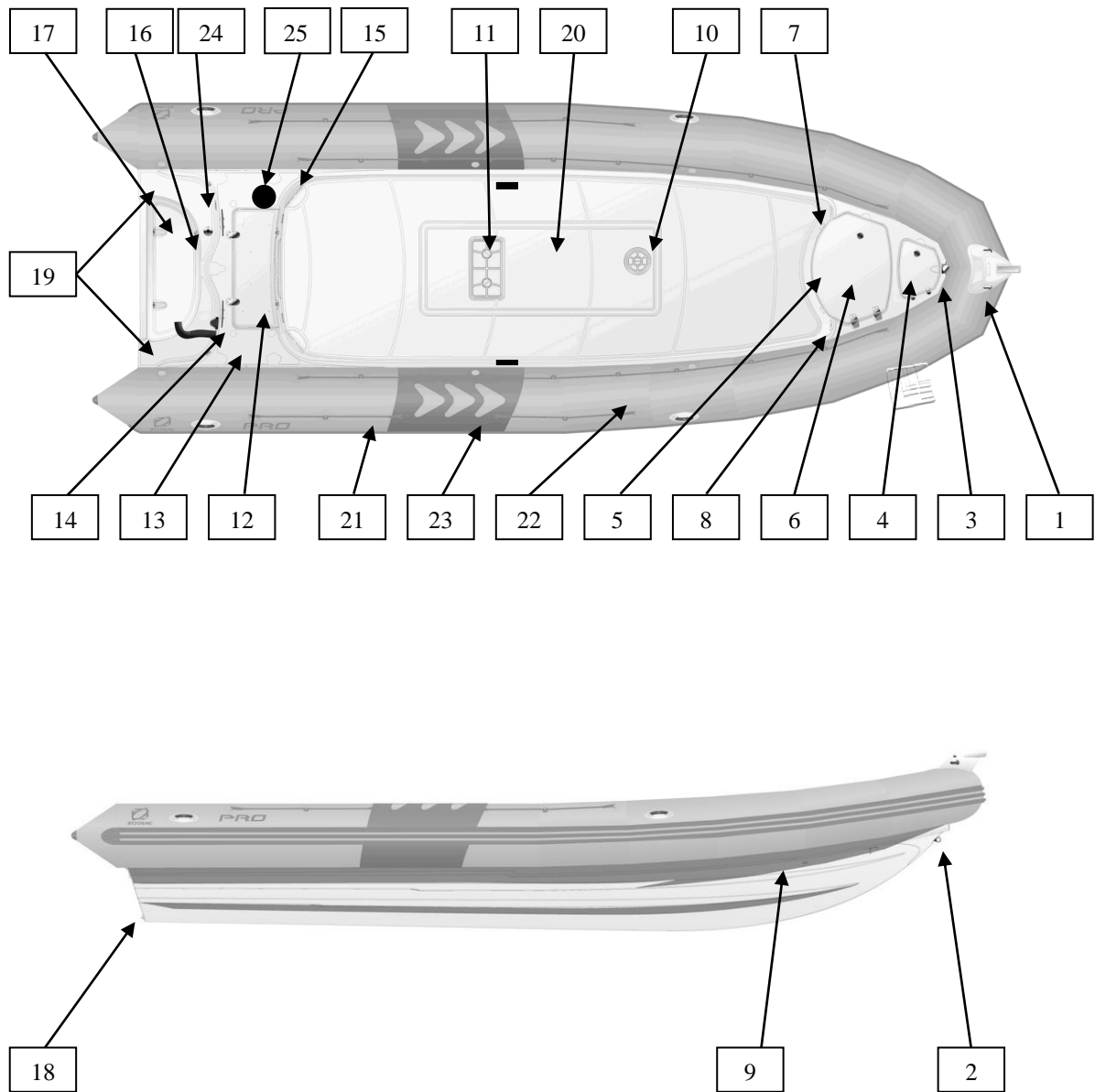



## DESCRIPCIÓN - Elementos funcionales

MARCA	DESCRIPCIÓN
1	Púlpito de proa + cornamusa + luces
2	Anilla de arrastre
3	Bitas de amarre
4	Cofre de ancla
5	Toma de combustible
6	Cofre extraíble de 75 litros
7	Rejilla de ventilación compartimiento depósito de combustible
8	Respiradero depósito de combustible
9	Evacuación desbordamiento de combustible
10	Registro acceso manguera depósito de combustible
11	Registro acceso válvula / aforador depósito de combustible
12	Tapa popa
13	Filtro separador agua / carburante
14	Salida cables motor
15	Desagüe de gran caudal
16	Bañera de popa
17	Desagües bañera
18	Desagüe de casco
19	Cadenotes tracción popa
20	Depósito de combustible
21	Flotador
22	Guirnalda
23	Logotipos pro
24	Cornamusas de proa
25	Base luz blanca

## DESCRIPCIÓN - Manipulación

### I -4-MANIPULACIÓN

#### I-4-1-Transporte

- Los consejos de colocación sobre remolque se especifican en el manual del propietario TOMO I.

#### I-4-2-Almacenaje

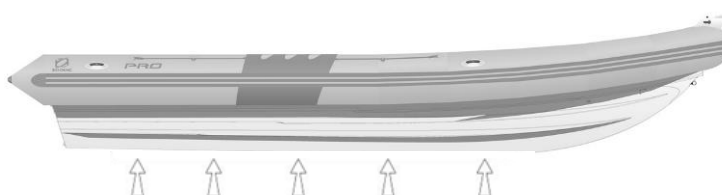

 <b>ATENCIÓN</b>	<b>LA EMBARCACIÓN DEBE APOYARSE OBLIGATORIAMENTE SOBRE LA QUILLA (VER CROQUIS A CONTINUACIÓN)</b>
--	---

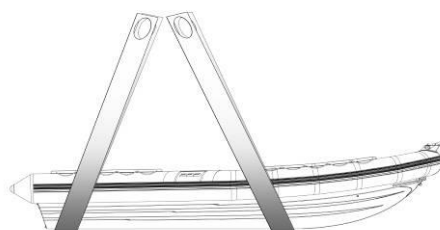

#### I -4-3-Izado: La embarcación no dispone de sistema de izado.

 <b>ADVERTENCIA</b>	<p><b>PUESTO QUE LA EMBARCACIÓN NO DISPONE DE SISTEMA DE IZADO, LA MANIOBRA DE IZADO DEBE EFECTUARSE OBLIGATORIAMENTE PASANDO LAS SANGLAS DE IZADO ADECUADAS POR DEBAJO DEL CASCO.</b></p> <p><b>PARA ESTA OPERACIÓN, CONSULTE CON ESPECIALISTAS EN IZADO.</b></p>
--	--



 <b>ATENCIÓN</b>	<b>NINGÚN PASAJERO A BORDO DURANTE EL IZADO CON GRÚA</b>
 <b>ADVERTENCIA</b>	<p><b>LA EMBARCACIÓN NO DEBE LLEVAR NINGUNA CARGA DURANTE EL IZADO CON GRÚA.</b></p> <p><b>ANTES DE BOTAR LA EMBARCACIÓN, ABRIR EL DESAGÜE (18) PARA ASEGURAR LA EVACUACIÓN EVENTUAL DE AGUA DE LLUVIA EN EL COCKPIT (VOLVER A CERRAR EL DESAGÜE ANTES DE BOTAR LA EMBARCACIÓN).</b></p>

# FLOTADOR – Montaje del flotador en el casco

## II-1-MONTAJE DEL FLOTADOR EN EL CASCO

1

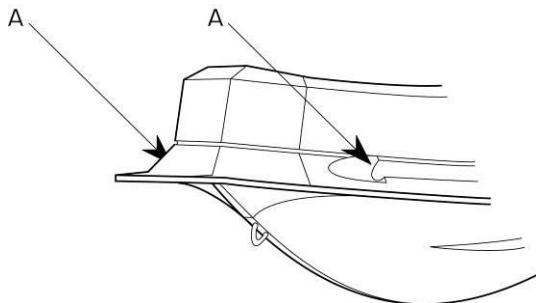

Para facilitar la colocación del flotador, poner jabón líquido (A) en los raíles del casco

2

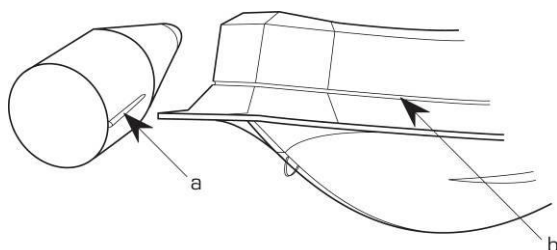

Coloque la relinga (a) del flotador en el raíl del casco (b) situado en la parte delantera del casco. Tire del flotador hasta que la mini-relinga quede frente al raíl de popa.

3

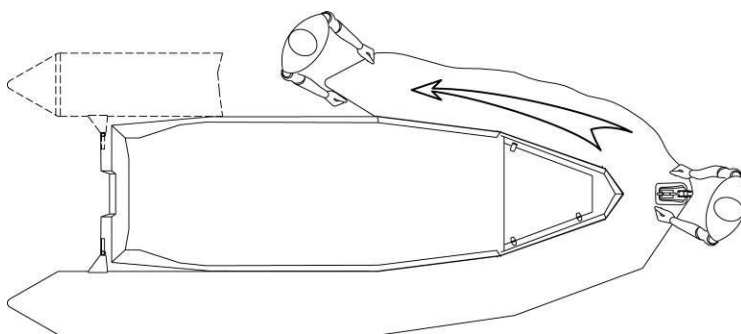

- Proceder del mismo modo para el otro lado del flotador.
- Tirar de la punta del flotador para pasar el faldón por el exterior de la punta del casco.
- Tirar nuevamente de los 2 extremos del flotador el máximo hacia la popa de la embarcación intentando centrar la punta respecto a la parte delantera del casco.
- Infle ligeramente la punta del flotador para comprobar que está bien centrado y se adapta perfectamente al casco. Repita la operación si el flotador no está bien colocado.

## FLOTADOR – Fijación del faldón



### II-2-FIJACIÓN DEL FALDÓN

4

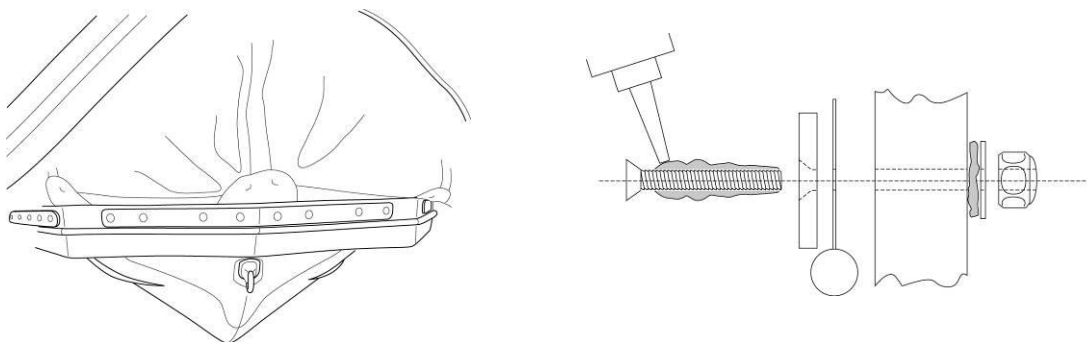
Fijar el faldón con la ayuda de las barras de acero inoxidable y de los pernos del kit del flotador. Colocar masilla de estanqueidad en todos los tornillos y en los orificios del casco para asegurar la estanqueidad.



<b>NOTA:</b>	<b>El montaje del flotador sobre el casco se efectúa con el flotador desinflado.</b>
--------------	--

	Puede inflar el flotador no montado (presión 240 mbar) y dejar que se estabilice aproximadamente una hora. A continuación, deshincharlo.
	Si el flotador ha estado almacenado a una temperatura inferior a 0 °C, dejarlo 12h en un lugar templado (20 °C) antes de desplegarlo.

# FLOTADOR - Sistema de inflado

## II-3-SISTEMA DE INFLADO

### II -3-1- El inflador

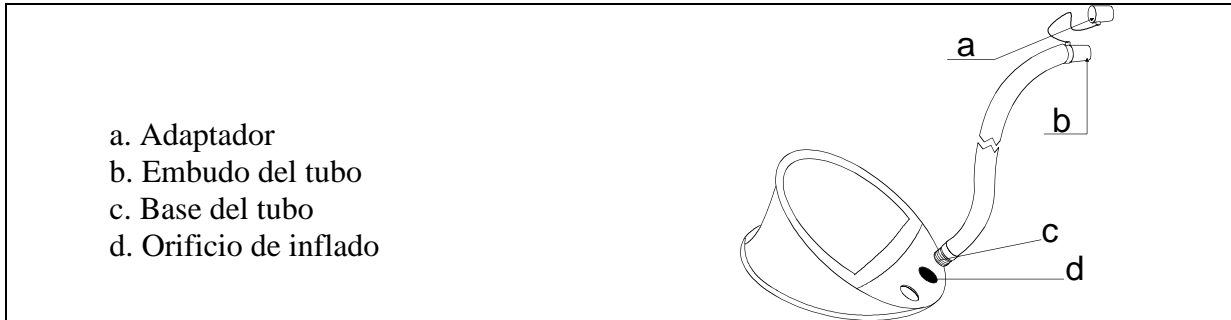

\* Existe un inflador eléctrico (12 V) de gran caudal disponible como opción (contacte con su distribuidor).

### II -3-2- Las válvulas

#### VÁLVULAS EASY PUSH

Para cambiar de posición	en posición de inflado	en posición de desinflado
 Empuje	 La membrana está cerrada, el empujador se encuentra en posición alta	 La membrana está abierta el empujador está en posición baja

**NOTA:** SIEMPRE SE DEBE VOLVER A PONER EL TAPÓN DE LA VÁLVULA DESPUÉS DEL INFLADO O DESINFLADO

## FLOTADOR - Sistema de inflado

### II -3-3- El indicador de presión

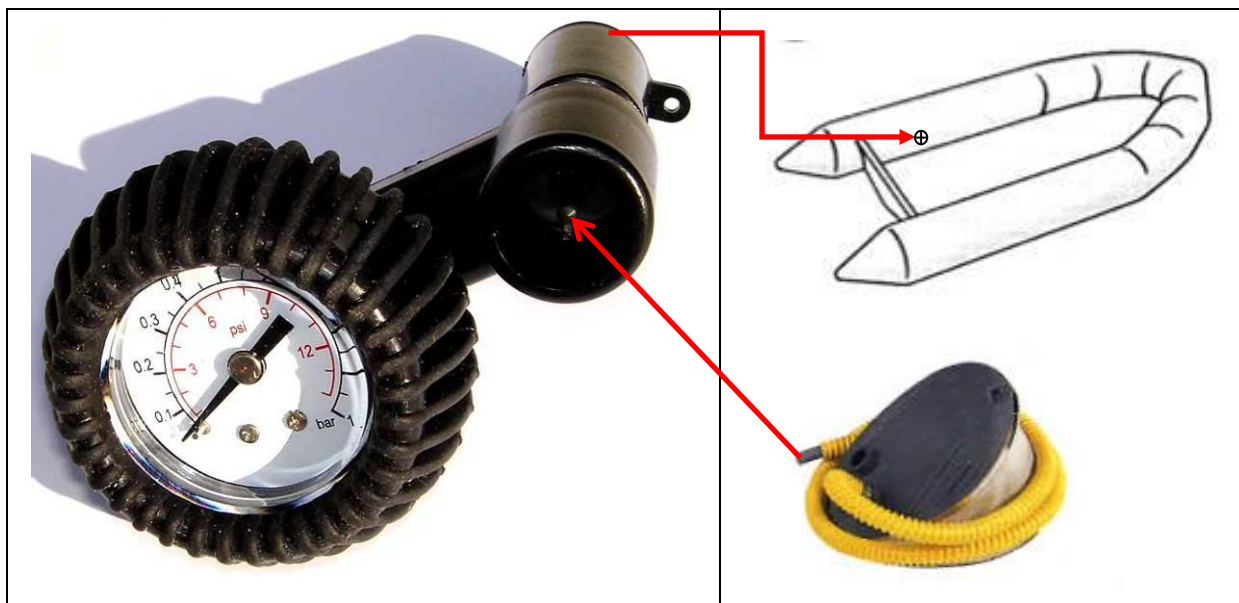

### II -3-4- Inflado del flotador

**Coloque todas las válvulas en posición de inflado.**

Fije la base del tubo en el orificio de inflado del inflador.

Para inflar correctamente su embarcación, el inflador debe estar bien asentado en el suelo. La embarcación se infla rápidamente si se acciona el inflador con suavidad y sin prisas.

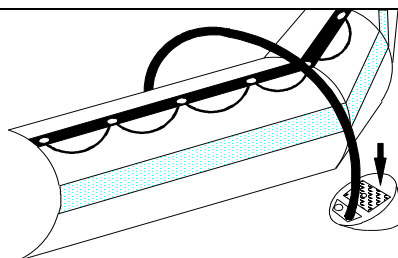

**NO UTILIZAR COMPRESOR O BOTELLA DE AIRE COMPRIMIDO.**

# FLOTADOR - Presión

## II -4-1- Inflado del flotador

- Añadir el adaptador correspondiente al diámetro de la válvula semi-encastrada al embudo del tubo del inflador.

Infle el flotador **equilibrando las presiones entre los diferentes compartimentos, hasta que los mamparos (a) no sean visibles (presión = 240 mbar).**

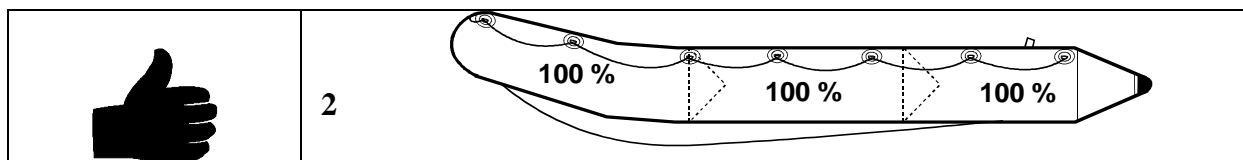
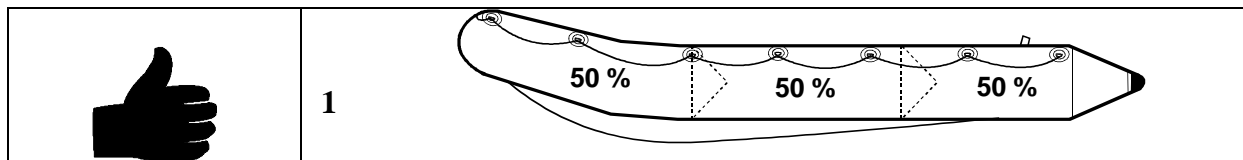
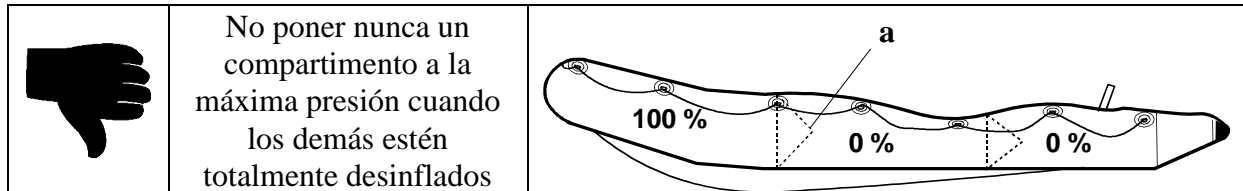

**El inflado ha terminado:** Enrosque los tapones de las válvulas de inflado.

<p><b>NOTA:</b></p>	<p><b>Es normal que se produzca una ligera fuga de aire antes de enroscar el tapón de válvula. Sólo los tapones garantizan la estanqueidad final.</b></p>
---------------------	---

## II -4-2- Presión

**La presión de utilización para el flotador es de 240 mb/3,4 PSI** (mitad de la zona verde del manómetro).

Su embarcación está equipada con un indicador de presión **ACCESS** que le permitirá una lectura rápida y eficaz durante el inflado (ver las explicaciones de utilización en la sección "Sistema de inflado").

<p>La temperatura ambiente del aire o del agua influye proporcionalmente en el nivel de la presión interna del flotador:</p>	<p>Temperatura ambiente</p>	<p>presión interna del flotador</p>
	<p>+1°C</p>	<p>+4 mb/0,06 PSI</p>
	<p>-1 °C</p>	<p>-4 mb/0,06 PSI</p>

## FLOTADOR - Presión

**También es importante saber anticiparse:**

**Compruebe y ajuste la presión de los compartimentos inflables (inflando o desinflando, según el caso) en función de las variaciones de temperatura (sobre todo si hay una gran diferencia de temperatura entre mañana y tarde en las zonas especialmente cálidas), y compruebe que la presión no se desvía de la zona de presión recomendada (de 220 a 270 mbar / zona verde).**

### RIESGO DE BAJA PRESIÓN:

**EJEMPLO:** Su embarcación está expuesta a pleno sol en la playa (temperatura = 50 °C) a la presión aconsejada (240 mb/3,4 PSI). Cuando lo ponga en el agua (temperatura = 20 °C), la temperatura y la presión interna de los compartimentos inflables bajarán a la vez (hasta 120 mbar) y **TENDRÁ QUE VOLVER A INFLAR** hasta ganar los milibares perdidos por la diferencia de temperatura entre el aire y el agua. También es normal observar una disminución de presión al final del día, cuando baja la temperatura exterior.

### RIESGO DE SOBREPRESIÓN:

**EJEMPLO:** Su embarcación está inflada a la presión aconsejada (240 mb/3,4 PSI) al principio o al final del día (temperatura exterior baja = 10 °C). Más tarde, durante el día, su embarcación está expuesta a pleno sol en la playa o sobre la cubierta de un yate (temperatura = 50 °C). La temperatura interior de los compartimentos inflables puede entonces aumentar y llegar hasta 70°C (especialmente los flotadores de color oscuro), duplicando la presión inicial (480 mbar). **TENDRÁ QUE DESINFLAR** para volver a la presión aconsejada.



**SI SU EMBARCACIÓN ESTÁ DEMASIADO INFLADA, LA PRESIÓN SOBRE LA ESTRUCTURA INFLABLE PUEDE SER EXCESIVA Y PROVOCAR UNA ROTURA DEL ENSAMBLAJE.**

### EN CASO DE SOBREPRESIÓN

**VÁLVULA EASY-PUSH :**  
Suelte el aire presionando el botón de la válvula.

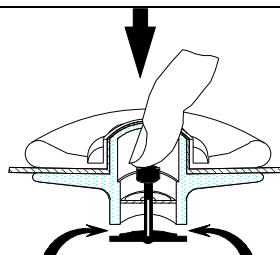



# SISTEMA DE PROPULSIÓN

Remítase a las recomendaciones de ZODIAC y a las del fabricante del motor para el montaje del/de los motores.

Para utilizar de forma óptima su embarcación, consulte con su distribuidor.

# INSTALACIÓN Y CIRCUITO - Combustible

## IV -1-COMBUSTIBLE

### IV -1-1-Descripción de los principales elementos funcionales:

La embarcación va equipada con un depósito de 400 litros situado bajo cubierta. El depósito se llena por la proa del barco, mediante un orificio de repostaje ubicado bajo el capó de proa.

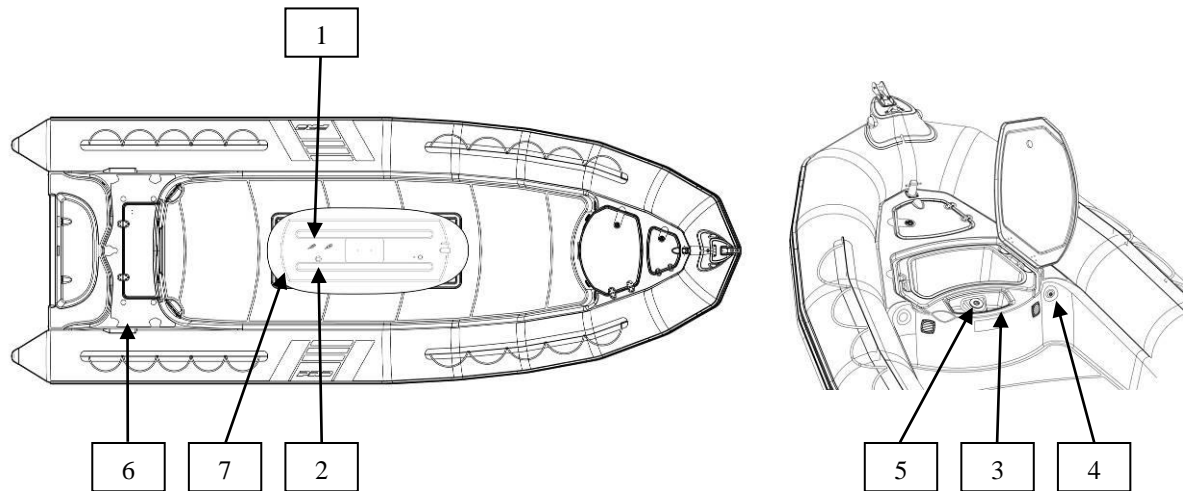

Nº	DESCRIPCIÓN
1	Llave de cierre del combustible
2	Transmisor del indicador de nivel
3	Desagüe del compartimento "desbordamiento"
4	Respiradero
5	Orificio de repostaje
6	Filtro separador agua / gasolina (suministrado para montaje monomotor)
7	Depósito de combustible

 <b>ADVERTENCIA</b>	<input checked="" type="checkbox"/> <b>EN CONFIGURACIÓN MONOMOTOR, NO OLVIDAR CERRAR LA VÁLVULA DE COMBUSTIBLE DEL SEGUNDO MOTOR.</b>
---	---

### IV -1-2-Depósito de combustible

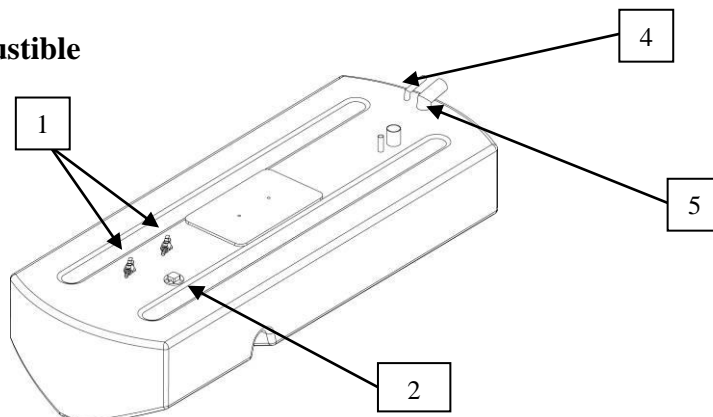

## INSTALACIÓN Y CIRCUITO - Combustible

### IV-1-3-1 Filtro separador Agua / Combustible

<b>NOTA:</b>	<b>Para proteger el motor, se ha instalado un filtro separador de agua / gasolina en el circuito de alimentación de combustible del motor.</b>
--------------	--

El filtro separador agua/combustible se encuentra en el tambucho de popa, en el lado de estribor (para una configuración bimotor, contacte con su distribuidor para obtener un segundo filtro).



Nº	DESCRIPCIÓN
1	Cabeza del filtro, fijada a la embarcación
2	Elemento de filtración intercambiable

 <b>ADVERTENCIA</b>	<b>EL RECAMBIO SE DEBA CAMBIAR CADA 50 HORAS DE USO.</b>
---	--

## INSTALACIÓN Y CIRCUITO - Combustible

### Cambio del cartucho del filtro:

Siga las recomendaciones ZODIAC y las del fabricante del filtro

Colocar un embudo debajo del lugar donde se colocará el recambio.

Antes de efectuar el cambio del filtro, debe liberarse la presión del sistema de alimentación de combustible.

Consulte el manual o las instrucciones del fabricante del motor.

El carburante es una materia extremadamente inflamable. **PARE EL MOTOR,** desconecte la batería y no fume ni efectúe la instalación del kit cerca de una llama.

Coloque un embudo debajo del lugar donde se efectuará el cambio.

Antes de cambiar el filtro, debe liberarse la presión del sistema de alimentación de combustible.



### IV-1-4- Utilización de las válvulas de cierre del circuito de combustible:

<b>NOTA:</b>	<ul style="list-style-type: none"><li>- Cuando ya no utilice su embarcación, cierre la válvula del circuito de combustible.</li><li>- Cuando vaya a utilizar su embarcación, abra la válvula del circuito de combustible.</li></ul>
--------------	---

Válvula del circuito de combustible  
Posición abierta

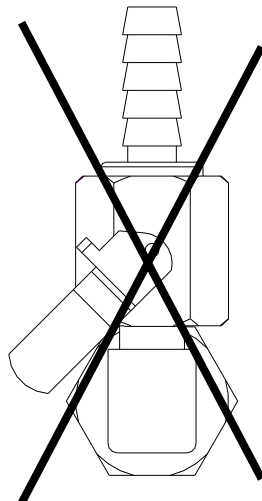
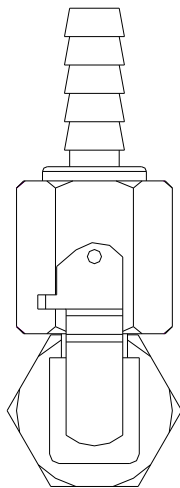



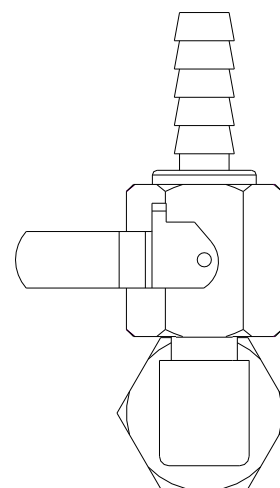

Válvula del circuito de combustible  
Posición cerrada



## INSTALACIÓN Y CIRCUITO - Combustible

### IV-1-5-Recomendaciones

 <p>ADVERTENCIA</p>	<p>EN CASO DE FUGA DE GASOLINA O INCENDIO, LA VÁLVULA DE CIERRE DEL CIRCUITO DE COMBUSTIBLE, SITUADA EN EL DEPÓSITO, PERMITE AISLAR EL DEPÓSITO DEL CIRCUITO DE COMBUSTIBLE Y DEBE PERMANECER CERRADA.</p>
 <p>ADVERTENCIA</p>	<p><input checked="" type="checkbox"/> UN DEPÓSITO LLENO EVITA LA CONDENSACIÓN EN CADA SALIDA. <input checked="" type="checkbox"/> HAGA LIMPIAR EL DEPÓSITO CADA 5 AÑOS. <input checked="" type="checkbox"/> COMPRUEBE EL AJUSTE DE LAS ABRAZADERAS DE TODOS LOS TUBOS. <input checked="" type="checkbox"/> CUANDO PURGUE EL FILTRO, NO VACÍE EL AGUA DENTRO DE LA EMBARCACIÓN. UTILICE UN RECIPIENTE DE RECUPERACIÓN DEBAJO DEL FILTRO. <input checked="" type="checkbox"/> CIERRE EL CONTACTO ANTES DE DESMONTAR EL CARTUCHO DEL FILTRO. <input checked="" type="checkbox"/> LEA ATENTAMENTE LAS INSTRUCCIONES DEL MANUAL DEL FILTRO.</p>
 <p>ADVERTENCIA</p>	<p><input checked="" type="checkbox"/> LA GASOLINA ES EXTREMADAMENTE INFLAMABLE. CUANDO MANIPULE EL SISTEMA DE CARBURANTE, ASEGÚRESE DE QUE LOS MOTORES ESTÉN PARADOS. NO FUMAR; MANTENER ALEJADA TODA LLAMA O CUERPO INCANDESCENTE DE LA ZONA DE TRABAJO.</p>
 <p>ADVERTENCIA</p>	<p><input checked="" type="checkbox"/> NO PERFORAR NUNCA EN LA ZONA DEL DEPÓSITO CON UN TALADRO CUYA BROCA SOBREPASE 30 MM (INDICADO EN LA CUBIERTA POR EL REGISTRO) Y NO UTILIZAR TORNILLOS DE MÁS DE 20 MM DE LONGITUD.</p>

# INSTALACIÓN Y CIRCUITO - Electricidad

## IV -2-ELECTRICIDAD

IV -2-1-Esquema de base (se suministra un plano en formato A3 con la caja de conexiones de la consola)

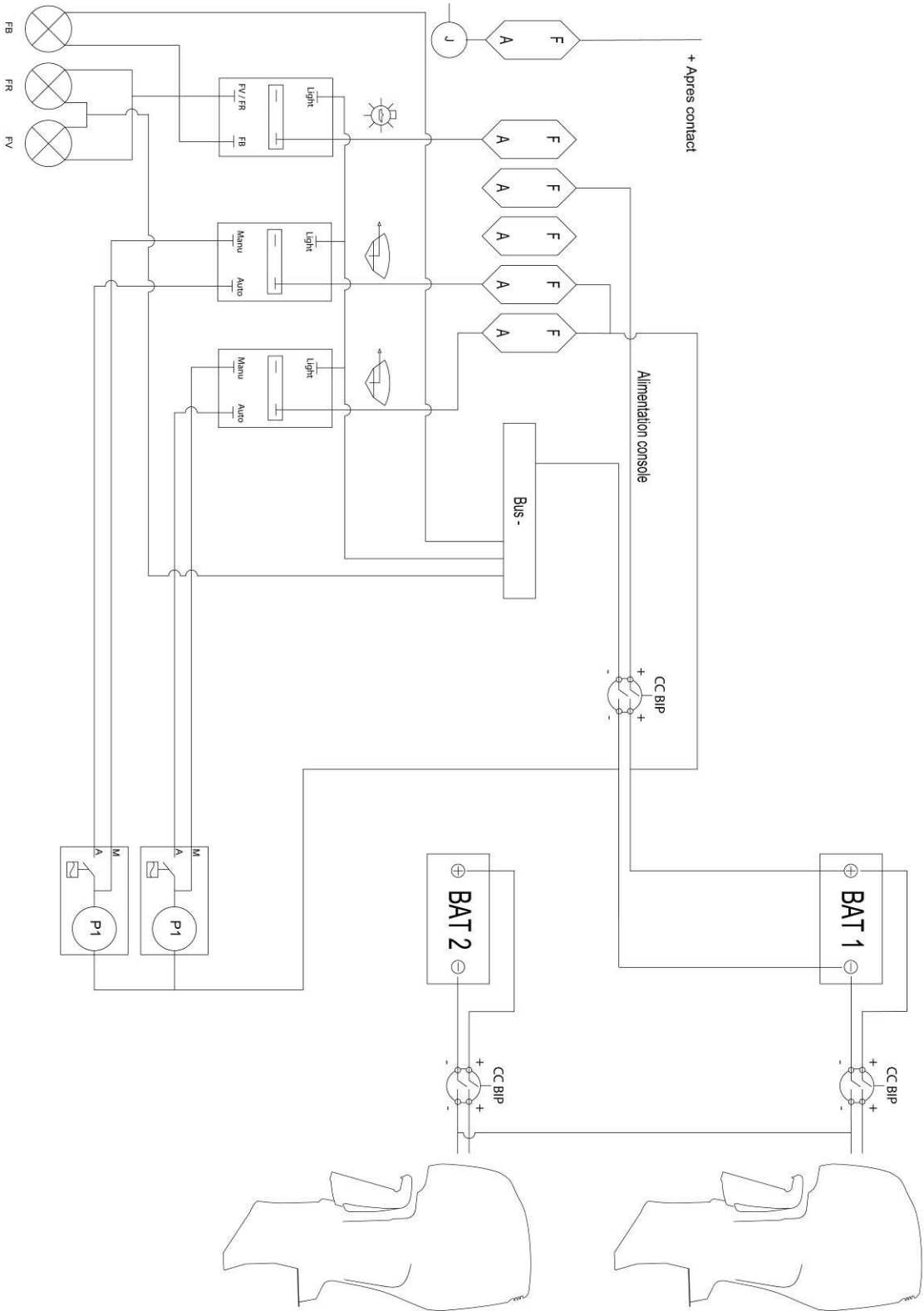



# INSTALACIÓN Y CIRCUITO - Electricidad

## IV-2-3 Localización de los elementos

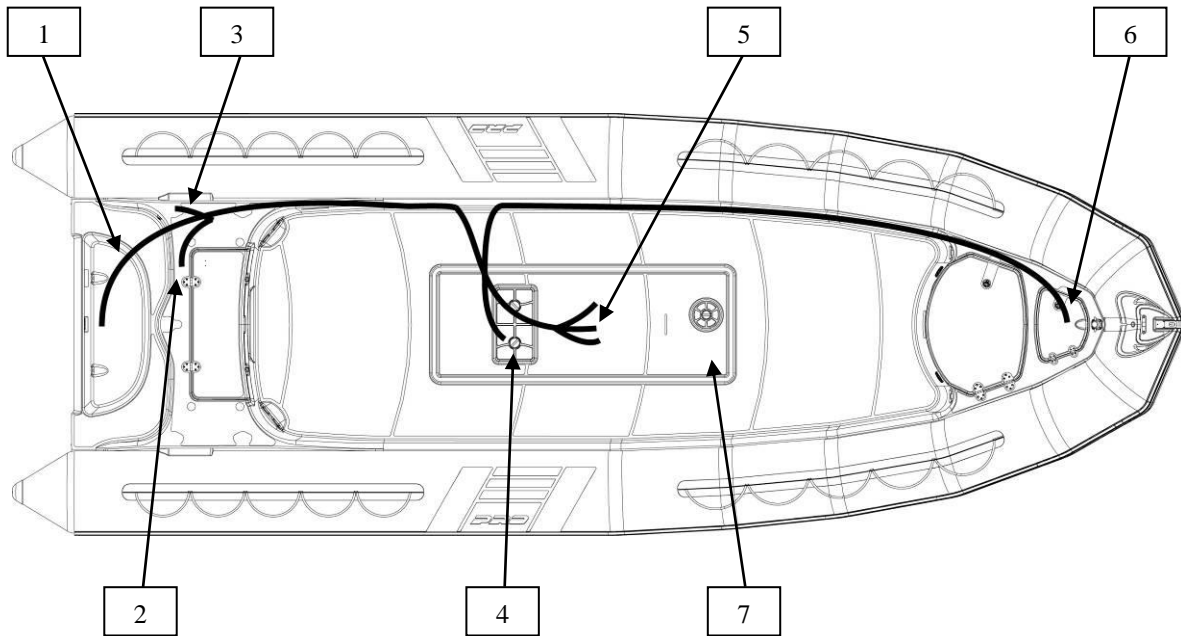

### Correspondencia:

N°	DESCRIPCIÓN
1	Alimentación bomba de achique
2	Soporte acopladores y desconector batería
3	Conexión libre para luz todo horizonte
4	Aforador depósito
5	Cable libre bajo el registro para cableado dentro de la consola
6	Conexión luces púlpito de proa
7	Posición del pasa cables

## IV-2-4-Cableado del cajetín e interruptor consola

Su embarcación está preequipada con cableado eléctrico, falta conectar algún elemento a la consola, a saber (el resto del cableado a conectar a la consola se encuentra bajo cubierta, n° 5)

- 1 Cajetín: repartidor (“bus bar” + porta fusible)

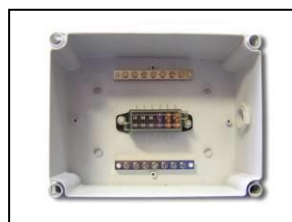



# INSTALACIÓN Y CIRCUITO - Electricidad

- Los interruptores de control de las luces + bombas de achique (también suministrados).

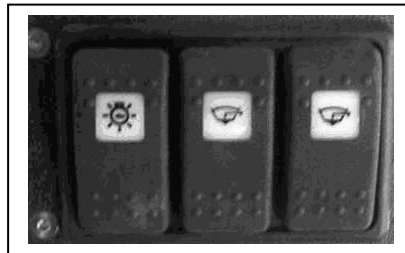

- El receptor del aforador de combustible.

## IV-2-5 Preparación del cableado.

### IV-2-5-1 Montaje del pasa cables (suministrado) (nº 7)

 <p><b>ADVERTENCIA</b></p>	<p><b>DURANTE EL PERFORADO, TENGA CUIDADO CON EL DEPÓSITO SITUADO JUSTO DEBAJO.</b></p>
---	---

1-Perforar en el ángulo (nº 7)

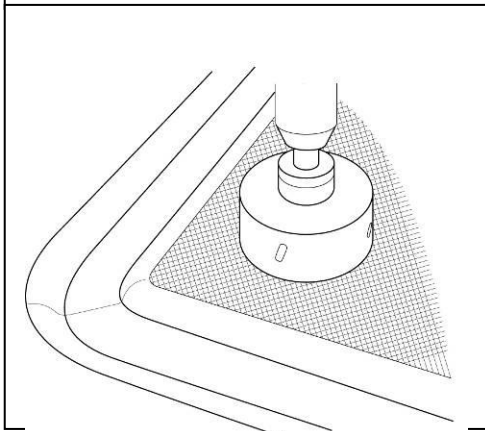

2- Recuperar los cables eléctricos del cableado libre (nº 5)

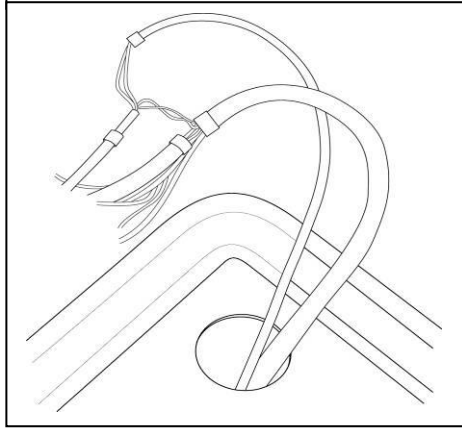

3- Situar la arandela para una perforación previa de la cubierta, luego perforar.

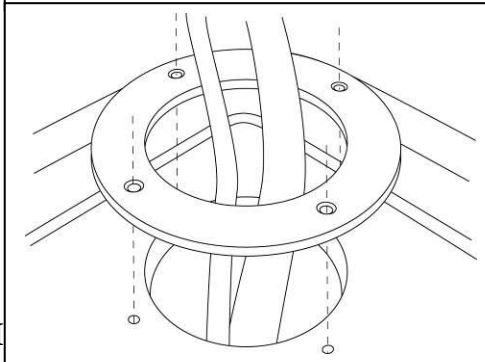

4 -Pasar el pasa cables, la brida y luego fijar el conjunto sobre la cubierta (asegurar la estanqueidad de los tornillos y la parte inferior del pasa-cables).

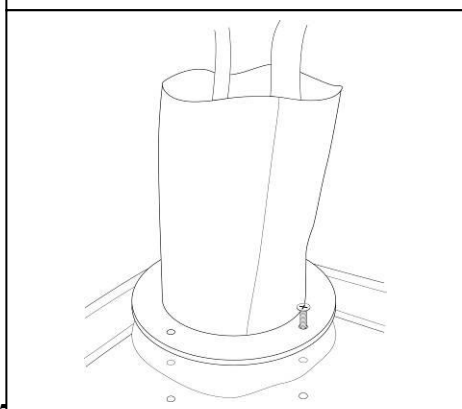

**E  
S  
P  
A  
Ñ  
O  
L**

# INSTALACIÓN Y CIRCUITO - Electricidad

Después de posicionar la consola sobre la cubierta y pasar los cables por el cajón de la consola (en el caso de consola T4), proceder a cablear el cajetín.

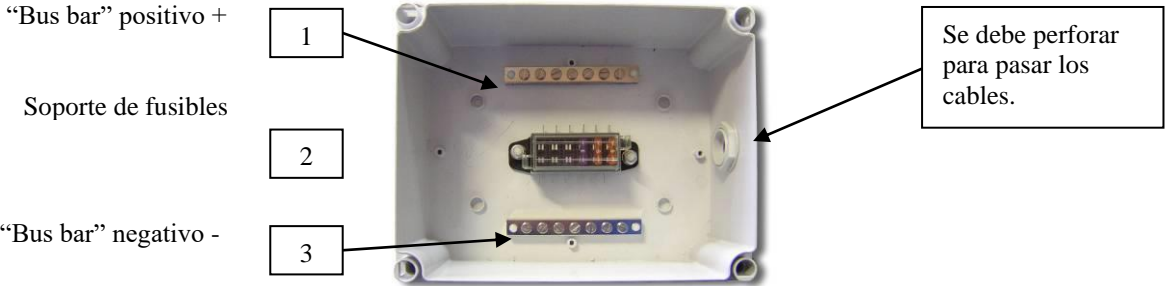

## IV-2-5-2: Cableado

- Paso 1: Conectar los cables siguientes al "bus" soporte fusible (nº 2).

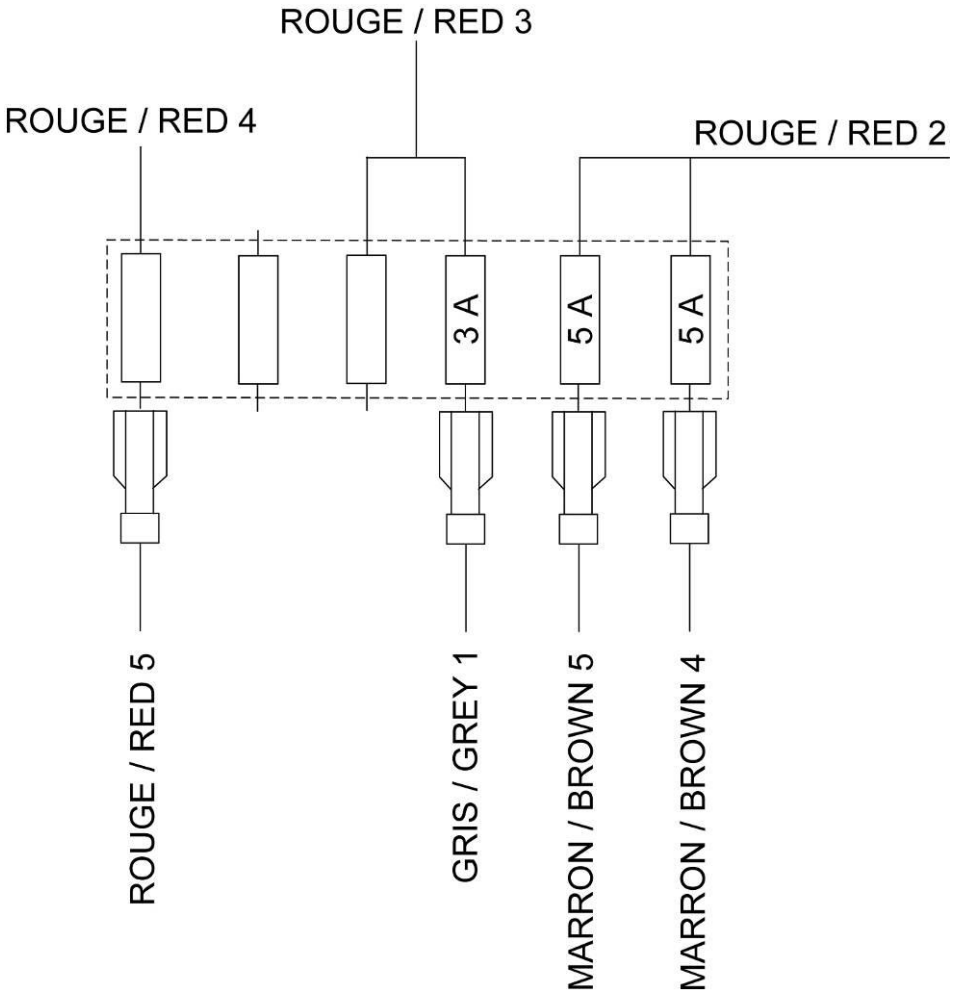

# INSTALACIÓN Y CIRCUITO - Electricidad

- Paso 2: Conectar los cables siguientes al “bus bar” negativo (nº 3).

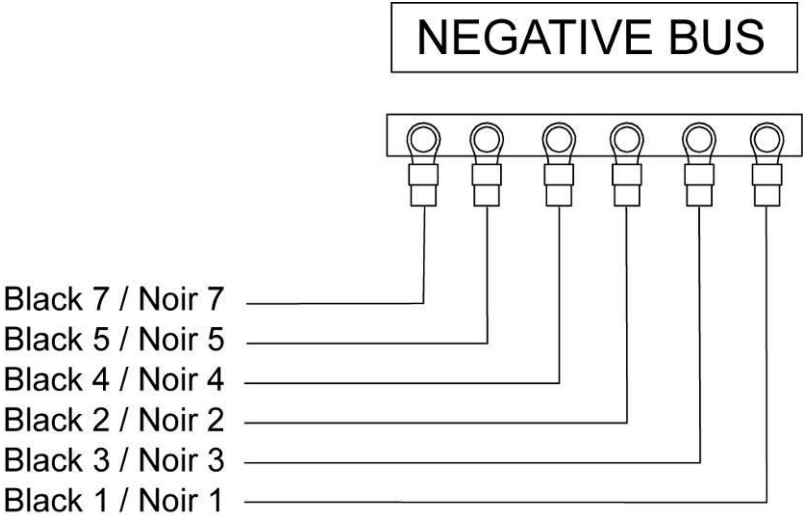

- Paso 3: Conectar los cables siguientes al “bus bar” positivo (nº 1).

- Paso 4: **Fijar el cajetín a la consola.**

Antes de fijar el cajetín en el lateral de la consola, encolar una placa de contrachapado a fin de obtener el espesor para efectuar el atornillado.

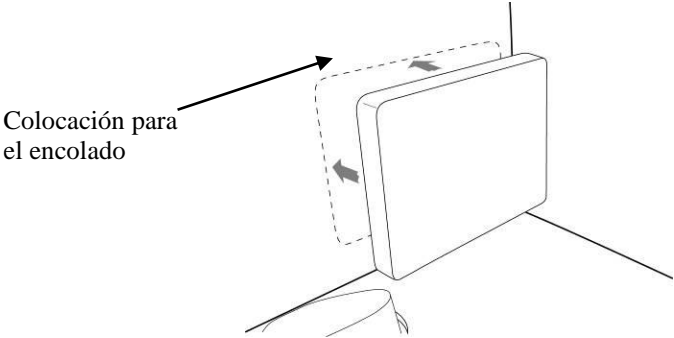

# INSTALACIÓN Y CIRCUITO - Electricidad

Fijar el cajetín a la placa con tornillos para madera (no suministrados)

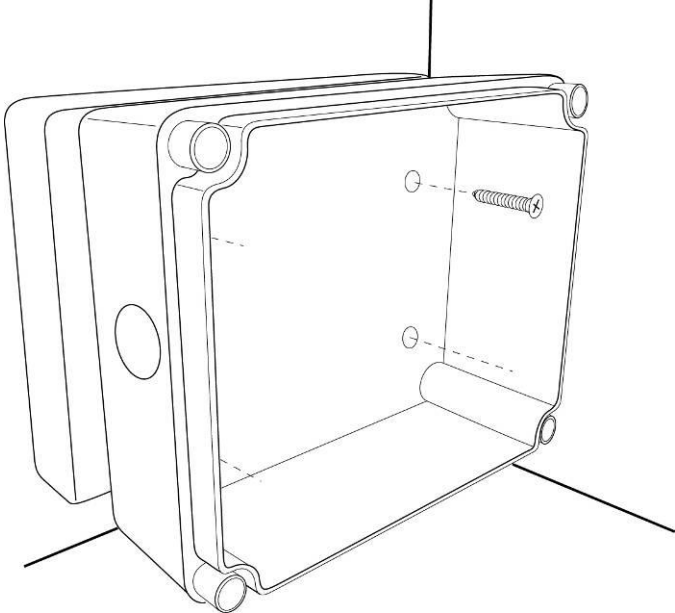

## IV-2-5-3: Cableado de los interruptores (bombas de achique + luces)

- Paso 1: Colocar los interruptores en la consola (teniendo en cuenta la longitud del cableado eléctrico).  
Si equipa su embarcación con una consola T4, le aconsejamos colocar el panel de interruptores como se indica a continuación.

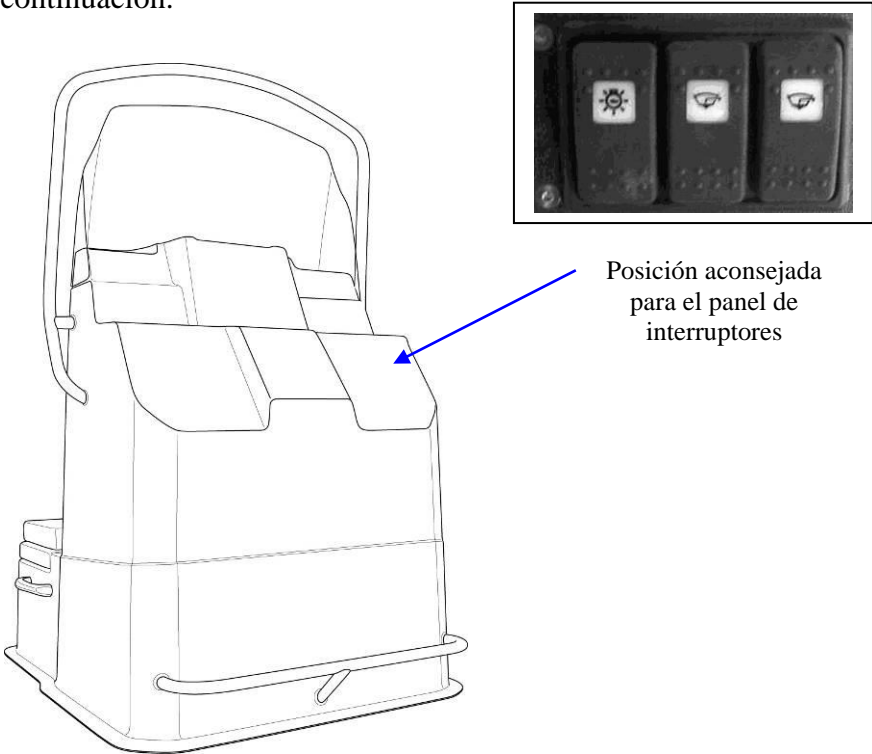

# INSTALACIÓN Y CIRCUITO - Electricidad

- Paso 2: Cableado

Conjunto de cables a conectar

Cableado visto desde la parte posterior de los interruptores.

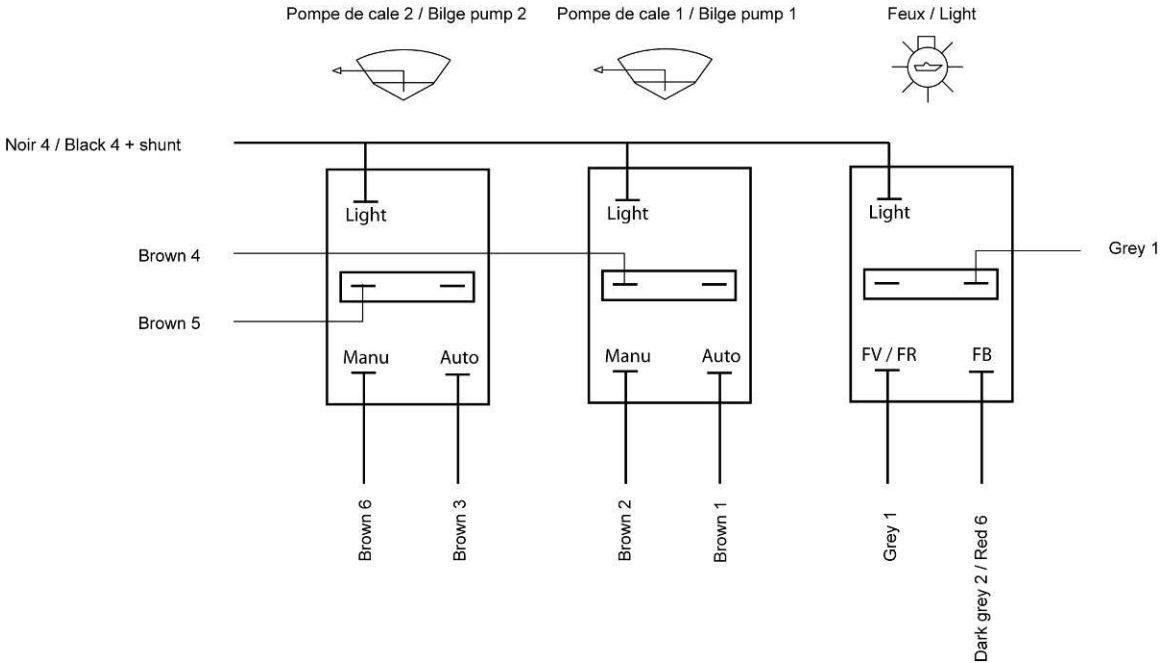

ESPAÑOL

# INSTALACIÓN Y CIRCUITO - Electricidad

## IV-2-5-4: Cableado del receptor del aforador de combustible (vista posterior).

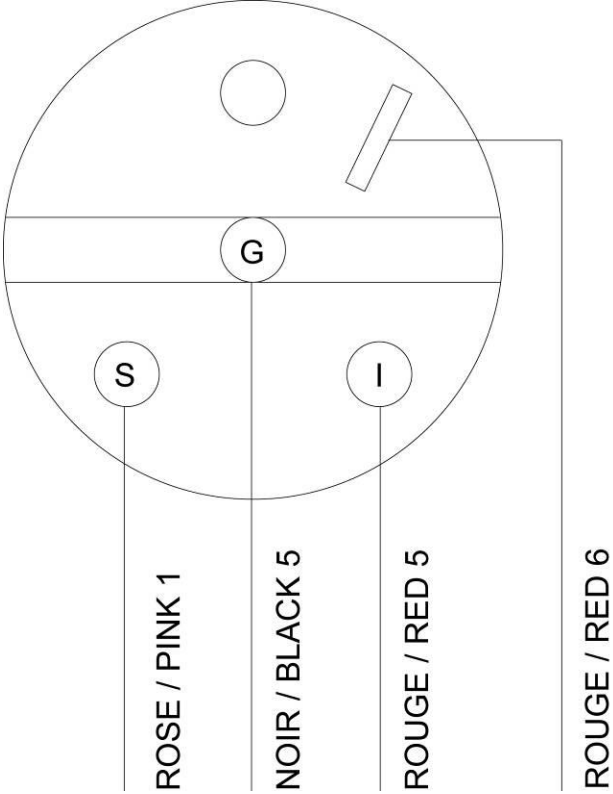

## IV-2-5-5 Funcionamiento del desconectador y de los conectores de batería

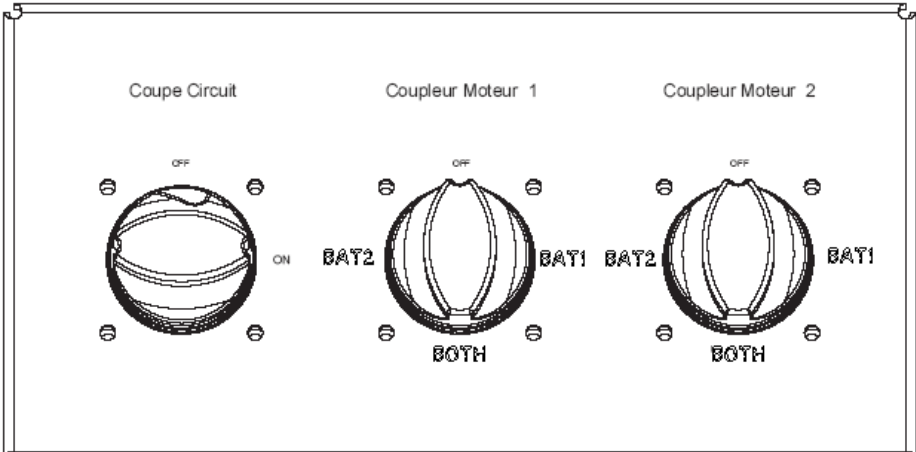

La embarcación va equipada de fábrica con un desconectador y dos conectores de batería (para montaje bimotor).  
Para montaje monomotor, sólo se utilizará un desconectador.

# INSTALACIÓN Y CIRCUITO

El desconectador permite aislar la alimentación del cajetín de la consola.

<b>NOTA:</b>	Tras cada utilización, recuerde poner el desconectador en posición OFF.
--------------	---

Los conectadores de baterías permiten poner en marcha los motores ya sea con una batería por motor, o conectando las baterías (en paralelo), o bien con una sola batería.

IV-2-5-6: Tabla de las distintas configuraciones posibles.

ESTADO CONECTADORES		RESULTADO
CONECTADOR 1 EN POSICIÓN "OFF"	CONECTADOR 2 EN POSICIÓN "OFF"	<i>LOS MOTORES Y LAS BATERÍAS ESTÁN AISLADOS</i>
CONECTADOR 1 EN POSICIÓN "BAT 1"	CONECTADOR 2 EN POSICIÓN "BAT 2"	<i>CADA MOTOR SE PONE EN MARCHA CON SU BATERÍA RESPECTIVA. PONER SIEMPRE LOS CONECTADORES EN ESTA CONFIGURACIÓN</i>
CONECTADOR 1 EN POSICIÓN "BAT 1"	CONECTADOR 2 EN POSICIÓN "BAT 1"	<i>LOS 2 MOTORES SE PONEN EN MARCHA CON LA BATERÍA 1 (si la batería 2 falla)</i>
CONECTADOR 1 EN POSICIÓN "BAT 2"	CONECTADOR 2 EN POSICIÓN "BAT 2"	<i>LOS 2 MOTORES SE PONEN EN MARCHA CON LA BATERÍA 2 (si la batería 1 falla)</i>
CONECTADOR 1 EN POSICIÓN "BOTH"	CONECTADOR 2 EN POSICIÓN "BOTH"	<i>LOS 2 MOTORES SE PONEN EN MARCHA CONECTANDO LAS 2 BATERÍAS</i>

# INSTALACIÓN Y CIRCUITO – Acometida de las opciones

## IV -2-6-ACOMETIDA DE LAS OPCIONES

### IV -2-6-1-Precauciones:

La embarcación va equipada de fábrica con 2 bombas de achique y luces de navegación. No obstante, quedan 2 posiciones libres en el cajetín de fusibles (bajo la consola) para conectar accesorios adicionales bajo ciertas condiciones:

- ① Los accesorios que quiera añadir se deberán conectar a la consola.
- ② Los accesorios se dividen en dos categorías:
  - A** → los accesorios que se utilizan o pueden utilizarse de modo continuo durante la utilización normal de la embarcación,
  - B** → los accesorios que se utilizan de modo intermitente.

A	
Ventilador sentina	
Radio	
Sonda	
GPS	
Proyector	
Sistema de alarma	
Nevera	
VHF	
$\Sigma$	180 W máx.

y

B	
Toma encendedor	
Iluminación diversa	
Bocina	
Equipamiento electrónico diverso	
Bomba ducha	
Potencia máx. seleccionada	60W máx

 <b>ADVERTENCIA</b>	<p><b>Debe comprobar obligatoriamente que la suma de las potencias de los accesorios <u>que añada</u> de la columna A es inferior o igual a 180 W (15 A) <u>Y</u> que la potencia máxima de un accesorio de la columna B debe ser inferior o igual a 60 W (5A).</b></p> <p><b>Las secciones de los distintos cables se han calculado con estos valores; no cumplir esta regla puede provocar problemas eléctricos y causar cortocircuitos.</b></p>
---	--

Puede conectar las opciones directamente al “bus bar” positivo y negativo de la consola (dentro del límite de la potencia máx.), insertando un porta fusibles homologado.



# INSTALACIÓN Y CIRCUITO – Conexión de opciones

## Ejemplo 1

Quiere añadir:

Una VHF de 72 W,

Un GPS de 36 W,

Una radio de 60 W,

Un encendedor de 72 W,

Un reloj de 20 W,

A	
Ventilador sentina	
Radio	60W
Sonda	
GPS	36W
Proyector	
Sistema de alarma	
Nevera	
VHF	72W
$\Sigma$	168W (<180W ) ☺

y

B	
Iluminación diversa	
Equipos electrónicos diversos	20 W (reloj)
Bomba de ducha	
Potencia máx. seleccionada	60W ( $\leq 60W$ ) ☺

CONCLUSIÓN



## Ejemplo 2

Quiere añadir:

Una VHF de 72 W,

Un GPS de 36 W,

Una radio de 48 W,

Un proyector de 120 W,

A	
Ventilador sentina	
Radio	48W
Sonda	
GPS	36W
Proyector	120W
Sistema de alarma	
Nevera	
VHF	60W
$\Sigma$	264W (> 120W) ☹

y

B	
Iluminación diversa	
Equipos electrónicos diversos	
Bomba de ducha	
Potencia máx. seleccionada	0 (< 60W) ☹

CONCLUSIÓN



# INSTALACIÓN Y CIRCUITO – Conexión de opciones

## Ejemplo 3

Quiere añadir:

Una VHF de 60 W,

Una radio de 60 W,

Una bocina de 120 W,

A	
Ventilador sentina	
Radio	60W
Sonda	
GPS	60W
Proyector	
Sistema de alarma	
Nevera	
VHF	
Σ	120W (< 180W) ☺

y

B	
Iluminación diversa	
Equipos electrónicos diversos	
Bomba de ducha	
Potencia máx. seleccionada	120W (> 60W) ☹

CONCLUSIÓN	☹
------------	---

<b>NOTA:</b>	<b>Algunos fabricantes indican el amperaje en lugar de la potencia absorbida. En corriente continua (este caso), basta con multiplicar por 12 para obtener la potencia y dividirla entre 12 para obtener la intensidad consumida por el aparato.</b>
--------------	--

### IV -4-2-6-2-Cableado:

- ① Escoger una localización de fusible libre,
- ② Conectar el cable de alimentación del accesorio al borne correspondiente a esta localización con una "terminal lengüeta" hembra de 6mm,
- ③ Si debe añadir cable para la conexión, utilice cable de 1,5mm<sup>2</sup> que cumpla las recomendaciones para cable "marino" (UL1426 ó SAE J378 ó SAE J1127 ó SAE J1128 o que cumpla en general con la recomendación ABYC y/o CE),
- ④ Conectar el cable de tierra del accesorio a la regleta de terminales de tierra con un guardacabo de Ø 5 (mismos comentarios que anteriormente para el cable),
- ⑤ Insertar un fusible tipo ATO de intensidad máxima de 15A y superior a la intensidad de utilización del aparato.

## INSTALACIÓN Y CIRCUITO – Conexión de opciones

### IV -2-7-FUNCIONAMIENTO DE LA BOMBA DE ACHIQUE

El funcionamiento de la bomba de achique es independiente de la posición del desconectador de la batería;

el interruptor de mando  siempre está encendido.

① Marcha automática (posición fija); en esta posición, el funcionamiento de la bomba de achique es automático. El indicador luminoso está encendido.

② Paro; en esta posición (posición fija), la bomba de achique está parada. El indicador luminoso está apagado.

③ Marcha forzada; se debe mantener el interruptor presionado para que la bomba de achique funcione en marcha forzada. Al soltar el interruptor, vuelve a la posición de paro (2).

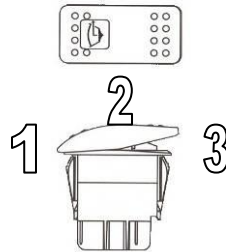

 <b>ADVERTENCIA</b>	<b>EN FONDEO, PONER EL INTERRUPTOR DE LA BOMBA DE ACHIQUE EN POSICIÓN MARCHA AUTOMÁTICA.</b>
---	--



<b>NOTA:</b>	<b>ZODIAC RECOMIENDA UTILIZAR UN TOLDO O LONA DE FONDEO PARA EVITAR QUE ENTRE EL AGUA EN CASO DE LLUVIA.</b>
--------------	--

# INSTALACIÓN Y CIRCUITO - Electricidad

## IV-2-8- Batería (no incluida)

Remítase a las recomendaciones de ZODIAC y a las del fabricante de baterías para el mantenimiento normal.

	<p><b>MANTENIMIENTO DE LA BATERÍA:</b></p> <ul style="list-style-type: none"> <li><input checked="" type="checkbox"/> Mantenga la batería limpia y seca para evitar un desgaste prematuro.</li> <li><input checked="" type="checkbox"/> Apriete y mantenga los terminales de los bornes engrasándolos regularmente con vaselina.</li> </ul>
---	---

 <b>ATENCIÓN</b>	<p><b>EL AGUA PROCEDENTE DEL SISTEMA DE TRAÍDA DE AGUAS CONTIENE MINERALES QUE DETERIORAN LAS BATERÍAS. POR ELLO, COMPLETE SIEMPRE EL NIVEL CON AGUA DESTILADA</b></p>
 <b>ADVERTENCIA</b>	<ul style="list-style-type: none"> <li>• <b>MANTENER LAS BATERÍAS Y EL ELECTROLITO FUERA DEL ALCANCE DE LOS NIÑOS</b></li> <li>• <b>NO INCLINE NUNCA LA BATERÍA.</b></li> <li>• <b>AL AÑADIR ELECTROLITO O RECARGAR LA BATERÍA, SACARLA SIEMPRE DEL COMPARTIMENTO MOTOR.</b></li> <li>• <b>EL ELECTROLITO DE BATERÍA ES UN LÍQUIDO TÓXICO Y PELIGROSO. CONTIENE ÁCIDO SULFÚRICO QUE PUEDE PROVOCAR GRAVES QUEMADURAS. EVITE EL CONTACTO CON LA PIEL, LOS OJOS Y LA ROPA.</b></li> <li>• <b>LAS BATERÍAS PUEDEN EMITIR GASES EXPLOSIVOS. MANTÉNGALAS ALEJADAS DE CHISPAS, LLAMAS, CIGARRILLOS, ETC.</b></li> <li>• <b>CUANDO CARGUE O UTILICE UNA BATERÍA, SITÚESE EN UN LUGAR BIEN VENTILADO. PROTÉJASE SIEMPRE LOS OJOS CUANDO TRABAJE CERCA DE UNA BATERÍA.</b></li> </ul>

<b>NOTA:</b>	<ul style="list-style-type: none"> <li><input checked="" type="checkbox"/> Si no va a utilizar su embarcación Zodiac durante un mes o más, retire la batería y guárdela en un lugar fresco, oscuro y seco. Recargue completamente la batería antes de volver a utilizarla</li> <li><input checked="" type="checkbox"/> Si la batería se ha de guardar durante un período más largo, verifique la densidad del electrolito al menos una vez al mes y recargue la batería cuando la densidad sea demasiado baja</li> </ul> <p><b>Densidad del electrolito: 1,28 a 20° C</b></p>
--------------	---

<b>NOTA:</b>	<p><b>Cuando ya no vaya a utilizar la embarcación, ponga el desconectador en posición OFF.</b></p>
--------------	--

# INSTALACIÓN Y CIRCUITO - Achique

## IV -3-ACHIQUÉ:

### IV -3-1-Descripción de los principales elementos funcionales:

La embarcación es auto-vaciante, tiene 4 desagües de gran caudal ubicados en la parte de popa.

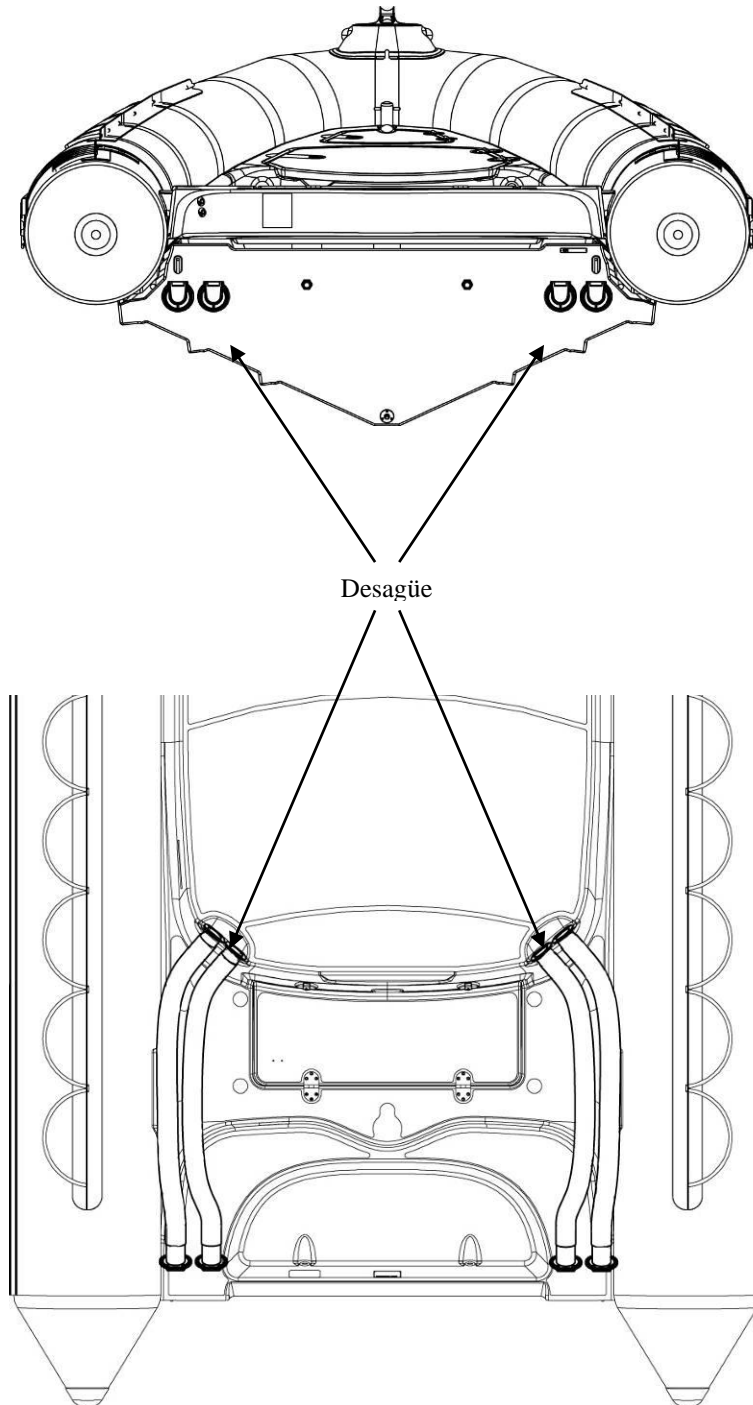

## INSTALACIÓN Y CIRCUITO - Achique

### IV-3-2-Desagüe del casco

#### IV-3-2-1-Embarcación fuera del agua (en remolque, cuna...)

	<b>POSICIÓN ABIERTA, TAPÓN DESAGÜE RETIRADO.</b>
---	--

#### IV-3-2-2-Embarcación en el agua

	<b>POSICIÓN CERRADA, TAPÓN DESAGÜE COLOCADO. (ASEGÚRESE DE QUE ESTÉ BIEN CERRADO)</b>
---	---

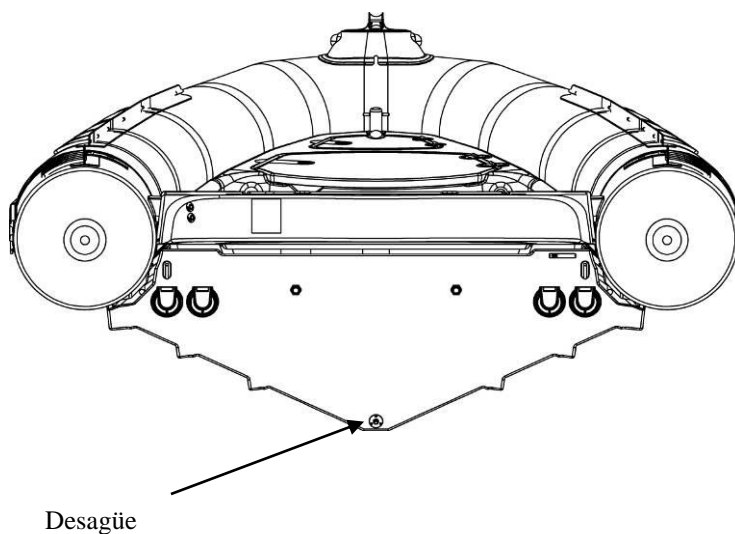

## **INSTALACIÓN Y CIRCUITO - Dirección**

### **IV-4-DIRECCIÓN**

Se puede utilizar una dirección hidráulica (opcional) para el montaje monomotor y, en algunos casos, el bimotor (ver la potencia máxima autorizada).

Siga las recomendaciones del fabricante de la dirección (instalación, utilización y mantenimiento).

Para utilizar de forma óptima su embarcación, consulte con su concesionario.

## **INSTALACIÓN Y CIRCUITO - Incendio**

### **IV-5- INCENDIO**



**ADVERTENCIA**

**RECOMENDAMOS LLEVAR UN EXTINTOR A BORDO Y CUMPLIR LAS LEYES VIGENTES DE SU PAÍS.**

# INSTALACIÓN Y CIRCUITO – Fondeo / amarre

## IV-6- FONDEO / AMARRE

### IV -6-1-Descripción de los principales elementos funcionales:

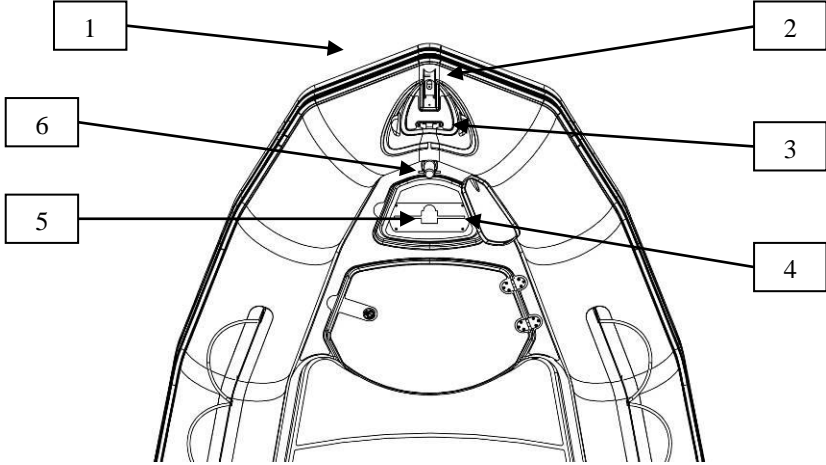

Nº	DESCRIPCIÓN
1	Cadenote de roda
2	Púlpito de proa + Roldana
3	Pasteca
4	Cofre de fondeo
5	Placa apoyo ancla
6	Bitas de amarre

### IV-6-2- Utilización

 <b>ADVERTENCIA</b>	<b>LA PASTECA Y LAS CORNAMUSAS SÓLO PERMITEN UN AMARRE OCASIONAL DE LA EMBARCACIÓN. EL AMARRE PERMANENTE DEBE EFECTUARSE MEDIANTE EL CADENOTE DE RODA SITUADO EN PROA.</b>
------------------------	--



# SEÑALIZACIÓN

## V-1-POSICIÓN DE LOS ADHESIVOS DE SEGURIDAD Y LAS PLACAS DE SEÑALIZACIÓN

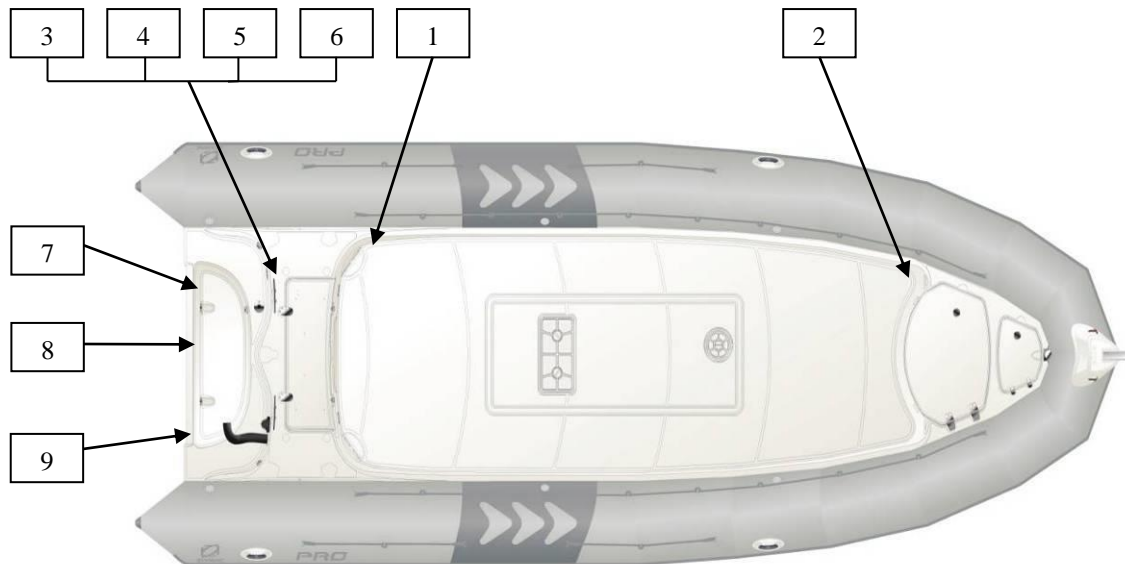

# SEÑALIZACIÓN

## V-2-DESCRIPCIÓN DE LOS ADHESIVOS DE SEGURIDAD Y LAS PLACAS DE SEÑALIZACIÓN



<b>⚠ WARNING</b>	<b>⚠ ADVERTENCIA</b>
<ul style="list-style-type: none"> <li>• DO NOT TOUCH BATTERY TERMINALS (SHOCK AND ACID HAZARDS)</li> <li>• DISCONNECT BOTH LEADS BEFORE REMOVING BATTERY</li> <li>• CONNECT RED LEAD TO POSITIVE (+) TERMINAL</li> <li>• CONNECT BLACK LEAD TO NEGATIVE (-) TERMINAL</li> </ul>	<ul style="list-style-type: none"> <li>• NO TOCAR LOS TERMINALES DE LA BATERIA (RIESGOS DE DESCARGA ELECTRICA Y DE CONTACTO CON EL ACIDO)</li> <li>• DESCONECTAR LOS DOS CABLES DE SALIDA ANTES DE EXTRAER LA BATERIA</li> <li>• CONECTAR EL CABLE ROJO AL BORNE (+)</li> <li>• CONECTAR EL CABLE NEGRO (O AMARILLO) AL BORNE (-)</li> </ul>

1



<b>⚠ WARNING</b>	<b>⚠ ADVERTENCIA</b>
<p style="text-align: center;"><b>GASOLINE IS HIGHLY INFLAMMABLE AND EXPLOSIVE</b></p> <ul style="list-style-type: none"> <li>• STOP ENGINE BEFORE REFUELING</li> <li>• REFUEL IN WELL VENTILATED AREA</li> <li>• NEVER REFUEL WHILE SMOKING, AROUND SPARKS OR OPEN FLAME</li> <li>• AVOID SPILLING FUEL. WIPE UP ALL FUEL SPILLS IMMEDIATELY</li> <li>• LEAKING FUEL IS A FIRE HAZARD AND EXPLOSION HAZARD</li> <li>• INSPECT FUEL SYSTEM BEFORE EACH USE</li> </ul>	<p style="text-align: center;"><b>LA GASOLINA ES ALTAMENTE INFLAMABLE Y EXPLOSIVA</b></p> <ul style="list-style-type: none"> <li>• APAGAR EL MOTOR ANTES DE LA REPOSTAR</li> <li>• REPOSTAR SOLO EN ZONAS BIEN VENTILADAS</li> <li>• NO FUMAR DURANTE EL REPOSTAJE</li> <li>• EVITAR DERRAMAR CARBURANTE. EN CASO DE PRODUCIRSE LIMPIAR INMEDIATAMENTE</li> <li>• LOS RESTOS DE COMBURANTE SON RIESGOS DE INCENDIO Y EXPLOSION</li> <li>• COMPROVAR EL CIRCUITO DE CARBURANTE ANTES DE CADA UTILIZACION</li> </ul>

2

<b>⚠ CAUTION</b>	<b>⚠ PRECAUCION</b>
<p style="text-align: center;"><b>IMPROPERLY TOWING YOUR BOAT CAN CAUSE SEVERE DAMAGE TO YOUR BOAT.</b></p> <ul style="list-style-type: none"> <li>• NEVER TOW IN OPEN SEAS</li> <li>• NEVER TOW ABOVE 6 KNOTS</li> </ul>	<p style="text-align: center;"><b>REMOLCAR DE MODO INADECUADO PUEDE DANAR SERIAMENTE SU EMBARCACION</b></p> <ul style="list-style-type: none"> <li>• NO REMOLCAR EN MAR ABIERTO</li> <li>• NO REMOLCAR A MAS DE 6 NUDOS</li> </ul>

3

<b>⚠ WARNING</b>	<b>⚠ ADVERTENCIA</b>
<p style="text-align: center;"><b>DO NOT LIFT THE BOAT WITH PASSENGERS ON BOARD</b></p>	<p style="text-align: center;"><b>NO IZAR LA EMBARCACION CON PASAJEROS A BORDO</b></p>

4

# SEÑALIZACIÓN

<b>⚠ DANGER</b>	<b>⚠ PELIGRO</b>
TO AVOID INJURY OR DEATH, SHUT OFF ENGINE WHEN NEAR SWIMMERS OR PRIOR TO USING SWIN PLATFORM AND BOARDING LADDER	PARA EVITAR LESIONES O LA MUERTE, APAGAR EL MOTOR AL APROXIMARSE A NADADORES Y ANTES DE USAR LA PLATAFORMA DE POPA O LA ESCALERA DE BANO
	<b>5</b>

<b>⚠ DANGER</b>	<b>⚠ PRECAUCION</b>
A FIRE EXTINGUISHER MUST BE CARRIED AT ALL TIMES	EN TODO MOMENTO SE DEBE LLEVAR UN EXTINTOR DE INCENDIOS
	<b>6</b>

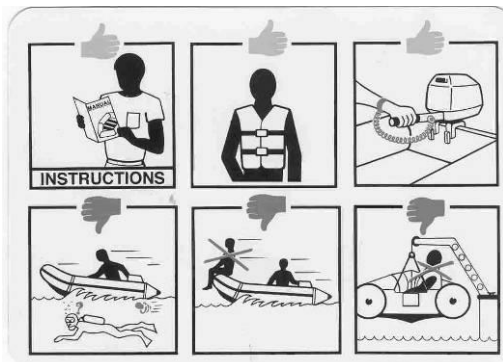

**7**

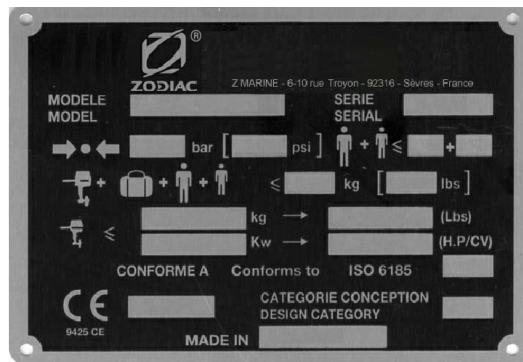

**8**



**9**

	ASEGÚRESE DE QUE LOS ADHESIVOS ESTÉN COLOCADOS Y SEAN LEGIBLES. CONTACTE CON SU DISTRIBUIDOR PARA OBTENER NUEVOS SI FUERA NECESARIO.
---	--

E  
S  
P  
A  
Ñ  
O  
L

## POSICIÓN ACCESORIOS OPCIONALES

### VI-1-POSICIÓN DE LA CONSOLA T4 (tanto para categoría de construcción B ó C)

Su embarcación se puede equipar con una consola opcional T4 (consulte con su distribuidor Zodiac).

Para optimizar la utilización de la embarcación y aprovechar todos los accesos bajo cubierta (acceso depósito/cableado eléctrico y paso de cables), recomendamos colocar la consola en la zona indicada a continuación.

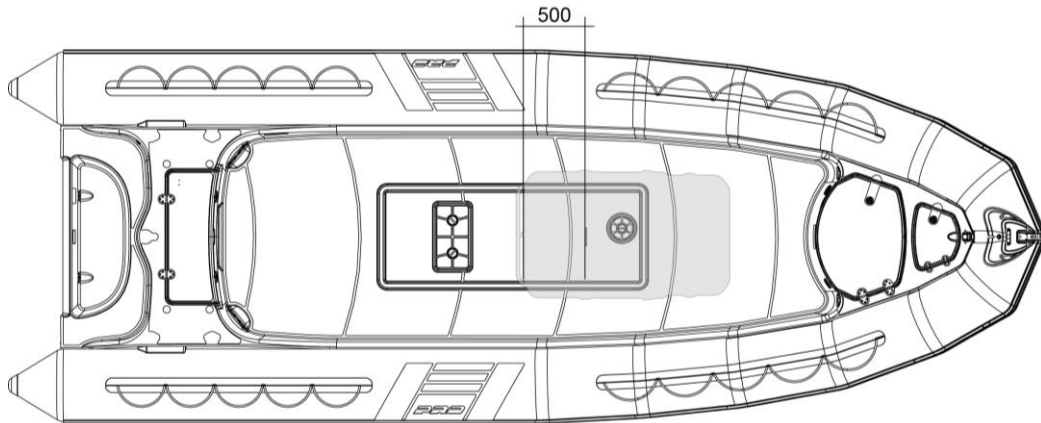

**ADVERTENCIA**

**DE LA EMBARCACIÓN, EL PASACABLES (NO SUMINISTRADO) DEBE COLOCARSE OBLIGATORIAMENTE EN LA ZONA SOMBREADA INDICADA ARRIBA.**

A

### VI-2-PASO DE LOS CABLES:

El paso de los cables y de la manguera de la gasolina del motor se ha previsto debajo de la cubierta de la embarcación (mediante forros previamente instalados en fábrica).

Salida de cables a cubierta (con un pasa cables).

Zona de paso de los cables.

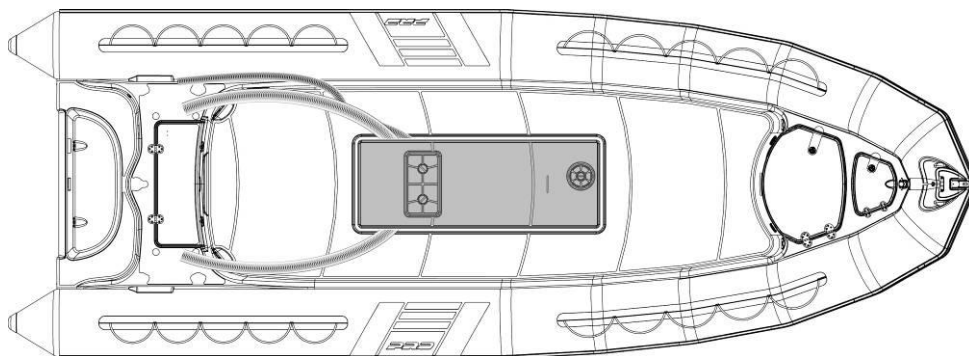
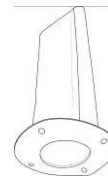

## POSICIÓN ACCESORIOS OPCIONALES

 <p>ADVERTENCIA</p>	<p>POR RAZONES DE SEGURIDAD, LA APERTURA DE LA TRAMPILLA DE ACCESO AL DEPÓSITO DE COMBUSTIBLE DEBE PERMANECER ACCESIBLE Y NO DEBE QUEDAR OBSTACULIZADA POR LA COLOCACIÓN DE UN ACCESORIO. SIN EMBARGO PUEDE ESTAR COMPLETAMENTE RECUBIERTA POR LA CONSOLA, PERO PERMANECER ACCESIBLE POR EL COFRE DELANTERO DE ESTA ÚLTIMA.</p>
--	---

 <p>ATENCIÓN</p>	<p>NO PERFORAR NUNCA EN LA ZONA DEL DEPÓSITO CON UN TALADRO CUYA BROCA SOBREPASE DE 30MM Y NO UTILIZAR TORNILLOS DE MÁS DE 20 MM DE LONGITUD.</p>
---	---

### VI-3-Posición de los accesorios ASIENTO T4 / BOLSTER T4 (según la categoría de construcción)

Según la categoría de construcción en la que se desea utilizar la embarcación, a continuación se muestran dos posiciones para el asiento o el bolster dependiendo de las plazas de asiento requeridas.

#### VI-3-1-Categoría C

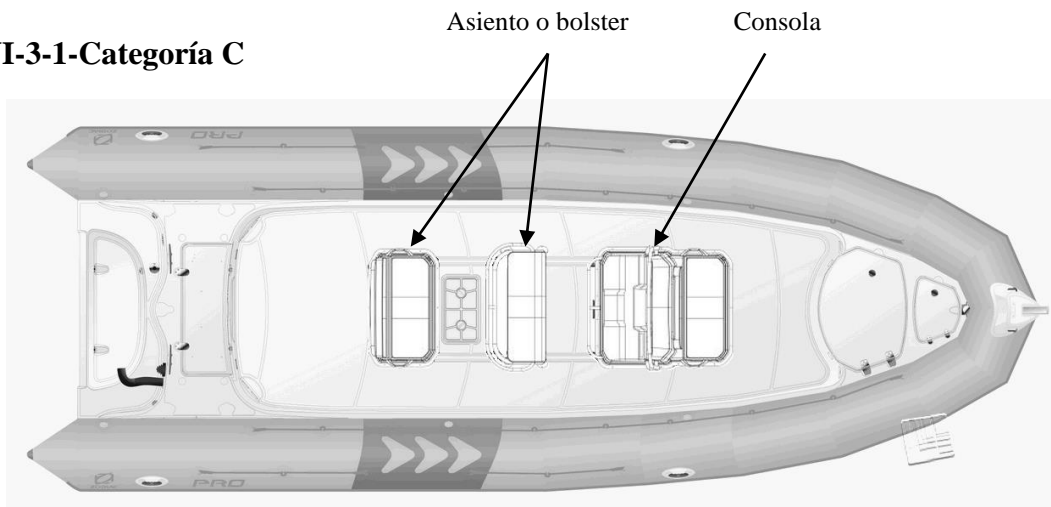

VI-3-2-Categoría B. El número de plazas en categoría B está limitado a 10 personas, todas deben estar sentadas.

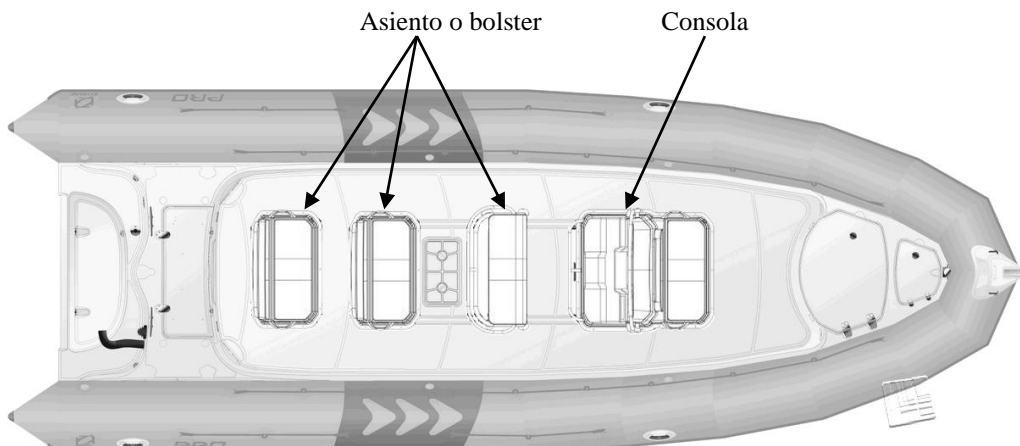

## POSICIÓN ACCESORIOS OPCIONALES

VI-4-Posición del accesorio ROLL BAR (con cada opción se entregan instrucciones más detalladas).

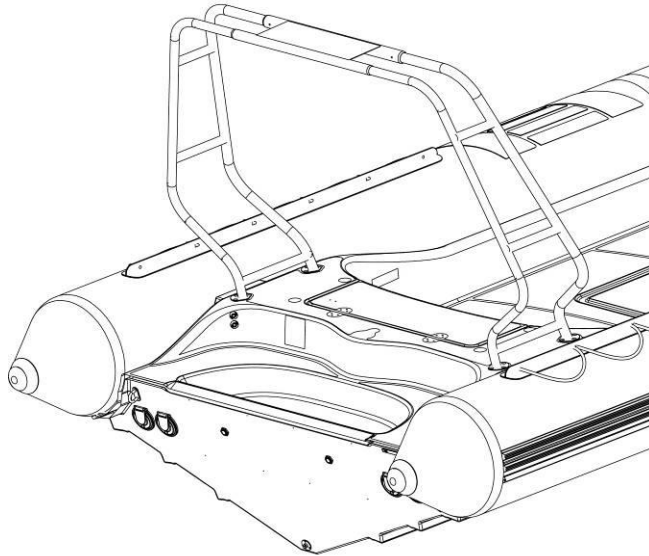

VI-5 Posición del accesorio mástil de esquí /respaldo posterior

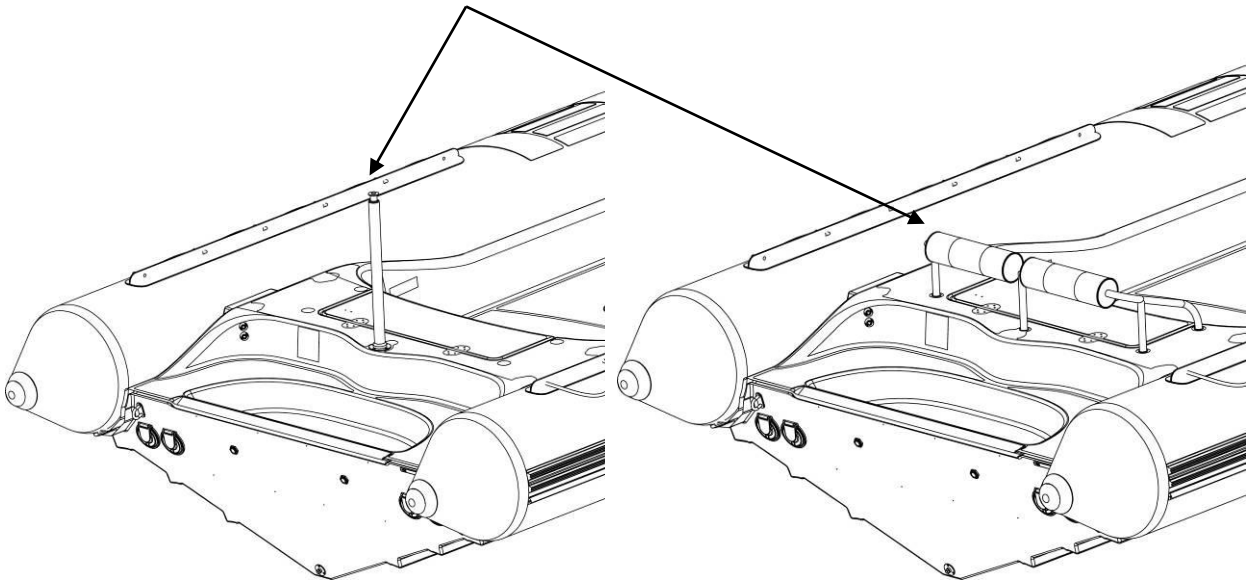

**NO UTILIZAR NUNCA EL MÁSTIL DE ESQUÍ PARA OTRO USO QUE ESQUÍ NÁUTICO O WAKE. PARA REMOLQUE O ARRASTRE, UTILICE LAS ANILLAS DE POPa.**

# POSICIÓN ACCESORIOS OPCIONALES

VI-6-Posición del accesorio T-TOP

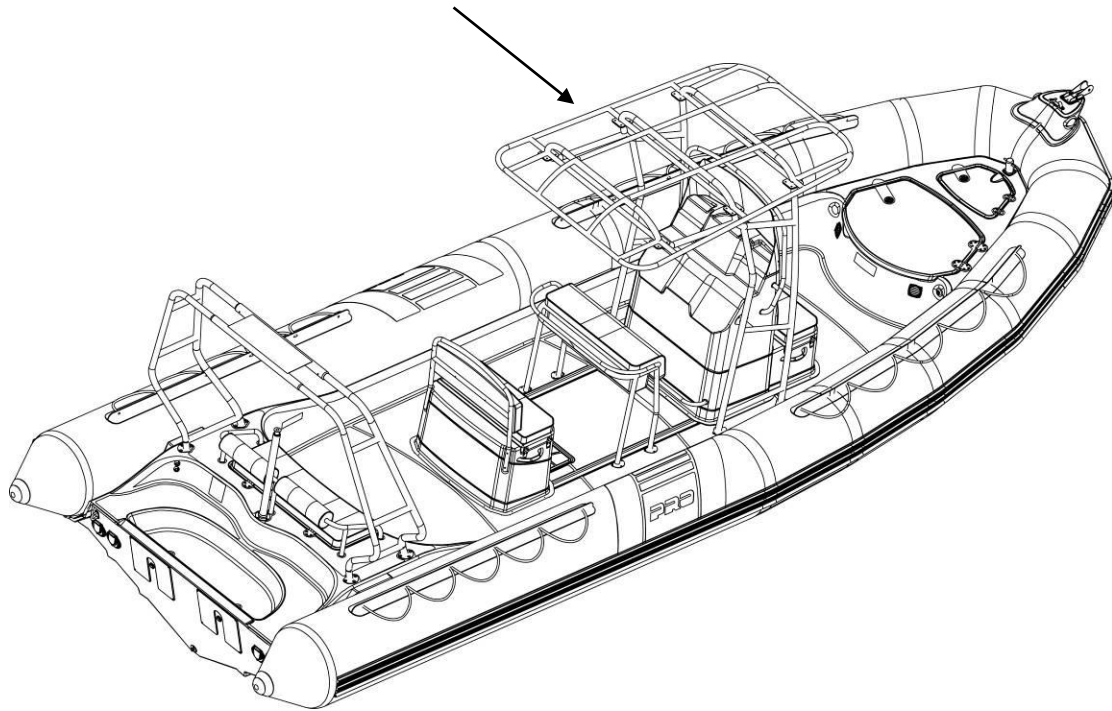



6-10 Rue Troyon  
92316- Sèvres - France

[www.zodiacmarine.com](http://www.zodiacmarine.com)

Pro 850

Code ZR20230

Edition 4





# **PRO**

## **PRO 850**

*Tome 2 – Volume 2*

*Teil 2 – Tomo 2*

7R20230

Edition 4



LIRE ATTENTIVEMENT CE MANUEL AVANT LA MISE EN SERVICE DE VOTRE ZODIAC.  
CAREFULLY READ THIS MANUAL BEFORE OPERATING YOUR ZODIAC.  
LEGGERE ATTENTAMENTE PRIMA DE INIZIARE IL MONTAGGIO DEL VOSTRO ZODIAC.  
VOR INBETRIEBNAHME IHRES ZODIAC VORLIEGENDES HANDBUCH AUFMERKSAM LESEN.  
LEER CUIDADOSAMENTE ESTE MANUAL ANTES DE PONER EN SERVICIO SU ZODIAC.



**Manuale del Proprietario  
Volume 2**

**PRO 850**





**VOLUME 2  
DESCRIZIONE - GOMMONE  
SISTEMA DI PROPULSIONE  
IMPIANTO E CIRCUITI**

# INDICE

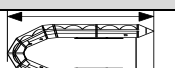

	PAGINA
<b>⇒ I – GENERALITA’</b>	
<b>I-1-Caratteristiche tecniche</b> -----	3 - 6
<b>I-2-Scheda tecnica</b> -----	6
<b>I-3-Ubicazione dei componenti</b> -----	7-8
<b>I-4-Movimentazione</b> -----	9
<b>⇒ II – IL GOMMONE</b>	
<b>II-1-Montaggio del gommone sullo scafo</b> -----	10
<b>II-2-Fissaggio del paraspruzzi</b> -----	11
<b>II-3-Sistema di gonfiaggio</b> -----	12-13
<b>II-4-Pressione</b> -----	14-15
<b>⇒ III - SISTEMA DI PROPULSIONE</b>	16
<b>⇒ IV - IMPIANTI E CIRCUITI</b>	
<b>IV-1-Carburante</b> -----	17-20
<b>IV-2-Impianto elettrico</b> -----	21-35
<b>IV-3-Asciugamento</b> -----	36-37
<b>IV-4-Sterzo</b> -----	38
<b>IV-5-Incendio</b> -----	38
<b>IV-6-Ormeggio/Ancoraggio</b> -----	39
<b>⇒ V – SEGNALETICA</b>	
<b>V-1-Posizione degli adesivi di sicurezza e targhe di</b> <b>immatricolazione</b> -----	40
<b>V-2-Descrizione degli adesivi di sicurezza e delle targhe di</b> <b>immatricolazione</b> -----	41-42
<b>⇒ VI – POSIZIONAMENTO / MONTAGGIO ACCESSORI OPTIONAL</b>	
<b>VI-1-Posizionamento console</b> -----	43-44
<b>VI-2-Posizionamento sedile / bolster</b> -----	44
<b>VI-3 Posizionamento rollbar</b> -----	45
<b>VI-4 Posizionamento asta per sci nautico / schienale posteriore</b> -----	45
<b>VI-5 Posizionamento TTOP</b> -----	46



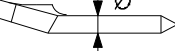

# DESCRIZIONE – Caratteristiche tecniche

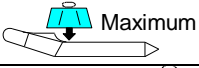
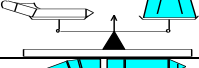

## I-1-CARATTERISTICHE TECNICHE

Dimensioni		
	(m)	8.5
	(ft)	27'10"
	(m)	7.45
	(ft)	24'5"
	(m)	3
	(ft)	9'10"
	(m)	1.85
	(ft)	6'
	(m)	0.6
	(ft)	1'11"

Categoria di concezione	
 (Direttiva 94/25/CE)	B / C

Capacità			
 (ISO)		B=10	C=20
	Kg <sup>(1)</sup>	2050	2800
	lb. <sup>(1)</sup>	4519	6173
	Kg <sup>(2)</sup>	1350	1350
	lb. <sup>(2)</sup>	2976	2976
 Compartimento		7	

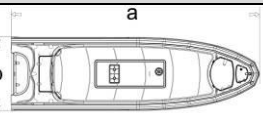
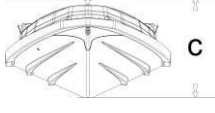
Motorizzazione				
Lunghezza dell'albero			MONOMOTORE	BIMOTORE
			XXL	XL
	Potenza MINIMA consigliata	CV <sup>(3)</sup>	250	2*175
		KW <sup>(3)</sup>	187	2*131
	Potenza MASSIMA consigliata	CV	300	2*225
		kW	225	2*168
	Potenza MASSIMA autorizzata	CV <sup>(3)</sup>	300	2*225
		KW <sup>(3)</sup>	225	2*168
	Peso MASSIMO motore	Kg	393	2*272
		Lb	866	2*600

Dimensioni scafo (optional esclusi)		
	a <sup>(4)</sup> (m)	7,78
	(ft)	25'6"
	b <sup>(4)</sup>	2,27
	(ft)	7'5"
	c <sup>(4)</sup> (m)	1,37
	(ft)	4'5"

## DESCRIZIONE – Caratteristiche tecniche

**Categoria di concezione :** Il vostro battello è stato progettato per essere omologato sia in categoria B che in categoria C. Questo comporta delle differenze di portata passeggeri e capacità di carico a seconda della categoria.

La categoria B permette una navigazione con 10 passeggeri a bordo. Ogni passeggero deve rimanere seduto e reggersi durante la navigazione.

Consigliamo l'uso degli accessori specifici Zodiac (Chiedete consiglio al vostro rivenditore di fiducia).

### **Posizione accessori SEDILE T4 / BOLSTER T4. (a seconda della categoria di concezione)**

A seconda della categoria di navigazione in cui si desidera utilizzare l'imbarcazione, sono previsti 2 posizionamenti del sedile o del bolster in base al numero di posti a sedere richiesto.

#### **VI-1-3-1-categoria C.**

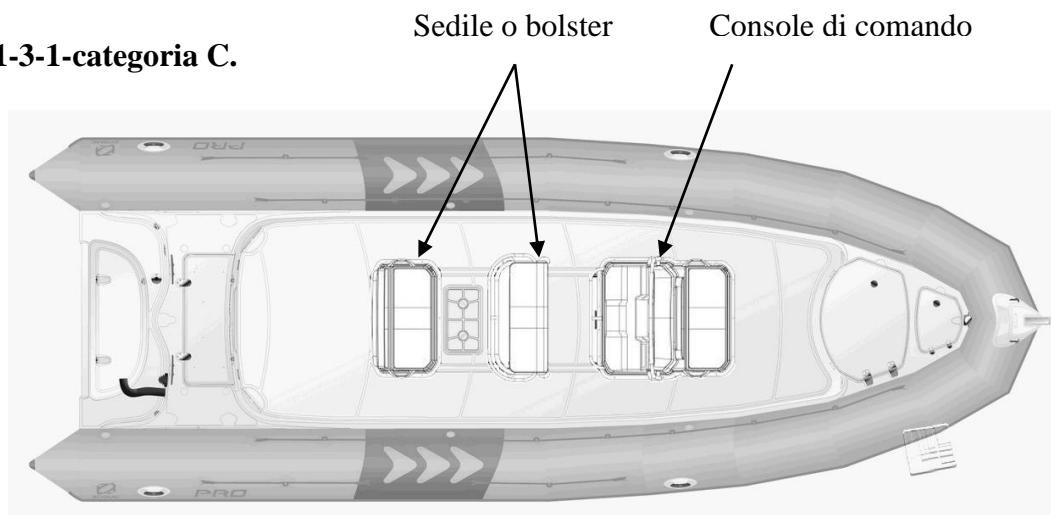

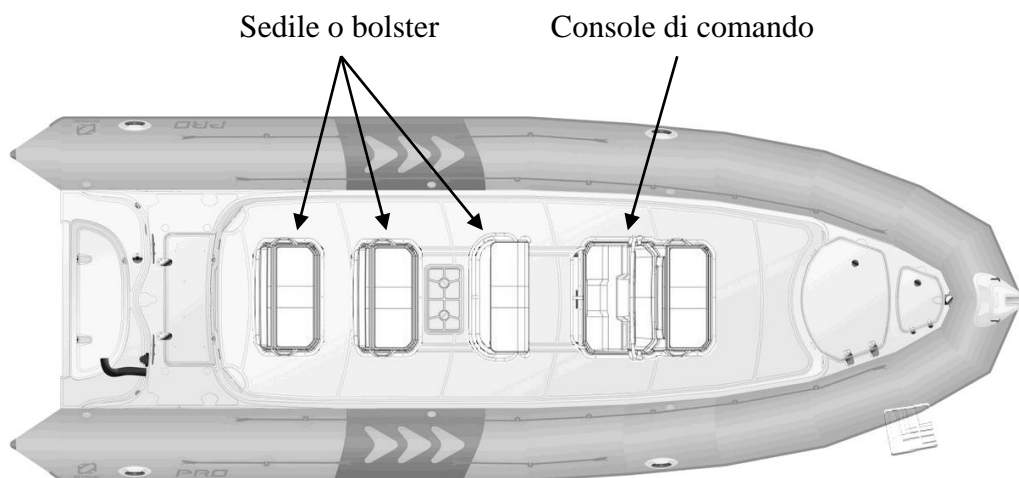

**VI-1-3-1-categoria B. Il numero di persone in categoria B è limitato a 10; tutte le persone devono essere sedute.**



<b>NOTA</b>	<b>Tolleranze dimensionali: +/- 4 %</b> <b>Tolleranze di peso: +/- 5%</b>
-------------	--

<b>NOTA</b>	<p><sup>(1)</sup> Il carico massimo consentito è stato calcolato in conformità alla norma ISO 6185. Si raccomanda di navigare con la massima prudenza quando l'imbarcazione è caricata fino al carico massimo consentito.</p> <p><sup>(2)</sup> Pesi indicati accessori esclusi</p> <p><sup>(3)</sup> Le potenze consigliate corrispondono ad uno sfruttamento ottimale delle capacità dell'imbarcazione per carico medio supportato.</p> <p><sup>(4)</sup> Dimensioni dello scafo senza gommone.</p> <p>Utilizzare con la massima prudenza la potenza massima autorizzata (vedi Volume 1 del manuale, capitolo "Consigli per la navigazione").</p>
-------------	---

 <b>ATTENZIONE</b>	<b>IL CARICO MASSIMO INDICATO SULLA TARGHETTA DEL FABBRICANTE NON DEVE ESSERE SUPERATO. IL CARICO MASSIMO INCLUDE LA MASSA DEL/I MOTORE/I, CARBURANTE, ACCESSORI, PASSEGGERI E RISPETTIVE ATTREZZATURE, E QUALSIASI ALTRO TIPO DI CARICO.</b>
--	---

 <b>ATTENZIONE</b>	<b>NON COLLOCARE PRODOTTI INFIAMMABILI NEL COMPARTIMENTO DI POPPA. E' SEVERAMENTE VIETATO CONSERVARE SULL'IMBARCAZIONE UN SERBATOIO D'EMERGENZA.</b>
--	--

## TUBOLARI - Pulizia

I tubolari di questo battello sono in tessuto Hypalon™ Néoprène™ 1670 dtex .

Per un miglior mantenimento vi raccomandiamo di pulire i tubolari con acqua insaponata o con detersivi ecologici come Revival, disponibile presso i concessionari Zodiac.

 <b>ATTENZIONE</b>	<b>NON USARE DETERGENTI CON SOLVENTI QUALI ACETATO E DERIVATI</b>
--	---

# SCHEDA TECNICA

## I-2-INVENTARIO

<b>SCAFO</b>
• Scafo in poliestere
• Ponte controstampato antiscivolo
• 1 Anello di prua
• 1 Pozzo dell'ancora
• 1 Cubia di ormeggio
• 1 Bitta di ormeggio
• 1 Gavone di prua + vasca amovibile (75 litri)
• 1 Gavone di poppa
• 2 Lande di trazione
• 1 Alleggio scafo
• Valvola di scarico rapido a flusso elevato
• 1 Serbatoio da 400 litri
• 1 Filtro di separazione acqua/benzina
• 1 Botola di accesso valvole / indicatore di livello circuito benzina
• 1 Botola di accesso raccordi tubi benzina
• Circuito elettrico con accoppiatori batterie e interruttore di sicurezza.
• 2 Pompe di sentina
<b>GOMMONE</b>
• Gommone amovibile in tessuto STRONGAN DUOTEX 2 X 1100 decitex
• 7 Valvole semi-incassate « easy-push »
• Banda antigraffio a profilo Ultra-largo
• 4impugnature esterne
• 2 Patch
• rizze
• Punte corte
• 1 Passacavo + puleggia + galloccia + fari
<b>EQUIPAGGIAMENTO STANDARD</b>
• 2 Pagaie
• Pompa a piede
• Manometro
• Valigetta di riparazione
<b>ACCESSORI OPTIONAL *</b>
• Console T4
• Sedile T4
• Bolster
• Schienale posteriore
• Asta per sci nautico
• Roll-bar
• T- top
• Scaletta di discesa
• Griglie porta-bombole per 4 e 6 bombole
• Pompa ad aria elettrica.

\* Per ulteriori informazioni sugli accessori optional disponibili, contattare il proprio rivenditore ZODIAC.

# DESCRIZIONE – Elementi funzionali

## I-3-UBICAZIONE DEI COMPONENTI

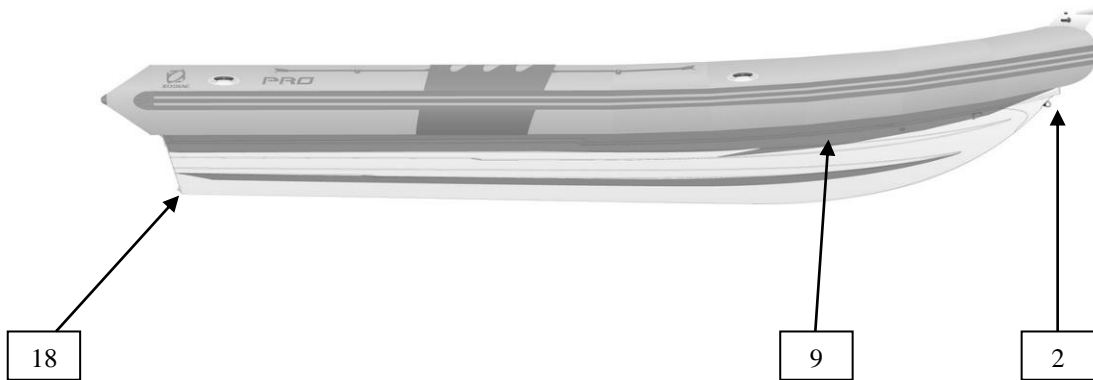
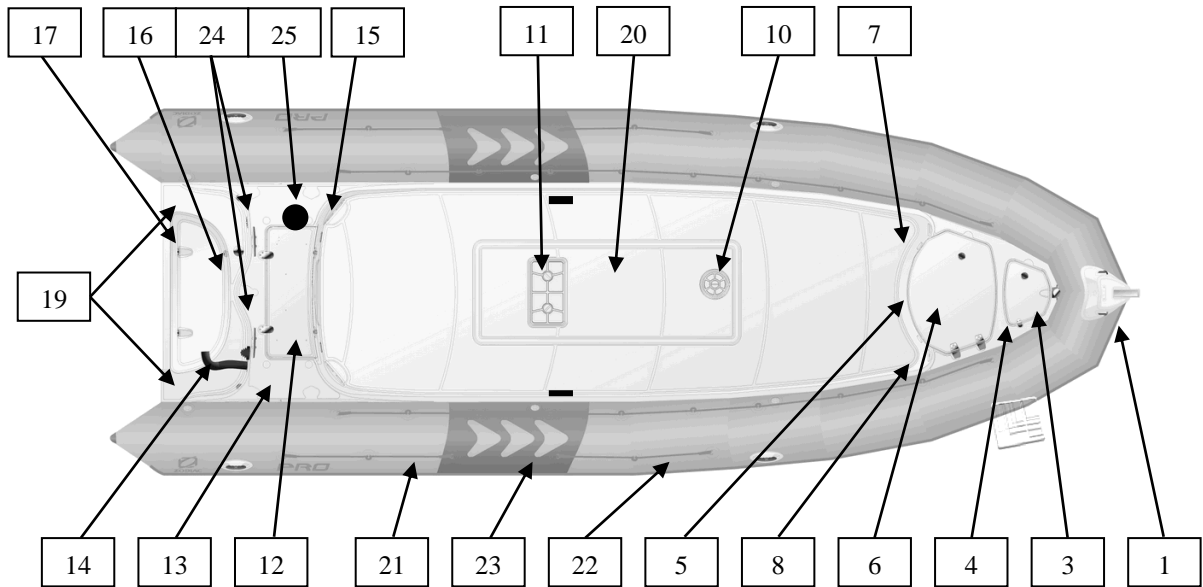

I  
T  
A  
L  
I  
A  
N  
O



## DESCRIZIONE – Elementi funzionali

RIFERIMENTO	DENOMINAZIONE
1	Passacavo con puleggia + galloccia + fari
2	Anello di prua
3	Bitta di ormeggio
4	Cofano pozzo dell'ancora
5	Riempimento carburante
6	Vasca amovibile da 75 litri
7	Griglia di ventilazione vano serbatoio
8	Sfiato serbatoio
9	Evacuazione troppo-pieno benzina
10	Botola di accesso tubo serbatoio.
11	Botola di accesso valvola / indicatore di livello serbatoio
12	Cofano posteriore
13	Filtro di separazione acqua/benzina
14	Passaggio cavi motore
15	Valvola di scarico rapido a flusso elevato
16	Vaschetta posteriore
17	Alleggi vaschetta
18	Alleggio scafo
19	Lande posteriori
20	Serbatoio
21	Gommone
22	Rizza
23	Logos pro
24	Anello posteriore
25	Base luce bianca

## DESCRIZIONE – Movimentazione

### I-4-MOVIMENTAZIONE

#### I-4-1-Trasporto:

- Le raccomandazioni per la messa su rimorchio sono specificate nel manuale del proprietario VOLUME I.

#### I-4-2-Deposito:

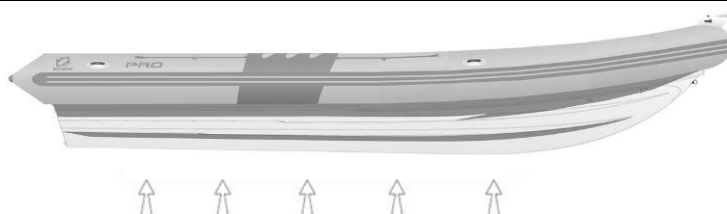

 <b>ATTENZIONE</b>	<p style="text-align: center;"><b>IL GOMMONE DEVE ASSOLUTAMENTE SOSTARE SULLA LINEA DI PRUA (VEDERE SCHIZZO SOTTOSTANTE).</b></p>
--	---

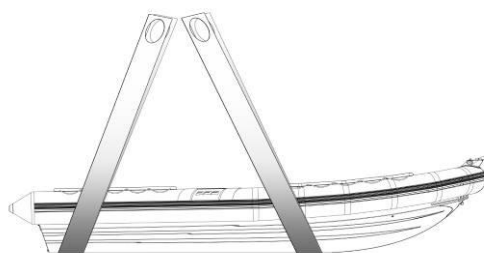

**I-4-3-Sollevamento:**  L'imbarcazione non dispone di mezzi di sollevamento.

 <b>ATTENZIONE</b>	<p style="text-align: center;"><b>L'IMBARCAZIONE NON DISPONE DI MEZZI DI SOLLEVAMENTO.</b></p> <p style="text-align: center;"><b>L'OPERAZIONE DI SOLLEVAMENTO DEVE ESSERE OBBLIGATORIAMENTE EFFETTUATA FACENDO PASSARE APPOSITI CAVI DI SOLLEVAMENTO SOTTO ALLO SCAFO.</b></p> <p style="text-align: center;"><b>PER QUESTA OPERAZIONE, RIVOLGERSI A PERSONALE ADDETTO AL SOLLEVAMENTO.</b></p>
---	---



 <b>ATTENZIONE</b>	<p><b>NESSUN PASSEGGERO A BORDO DURANTE IL SOLLEVAMENTO</b></p>
 <b>ATTENZIONE</b>	<p style="text-align: center;"><b>L'IMBARCAZIONE DEVE RISULTARE COMPLETAMENTE PRIVA DI QUALSIASI MATERIALE DURANTE IL SOLLEVAMENTO.</b></p> <p style="text-align: center;"><b>APRIRE L'ALLEGGIO (18) PRIMA DELLA MESSA IN ACQUA DELL'IMBARCAZIONE PER GARANTIRE L'EVACUAZIONE DELL'EVENTUALE ACQUA PIOVANA PRESENTE NEL COCKPIT (RICHIUDERE L'ALLEGGIO PRIMA DELLA MESSA IN ACQUA).</b></p>

# GOMMONE – Montaggio del gommone sullo scafo

## II-1-MONTAGGIO DEL GOMMONE SULLO SCAFO

1

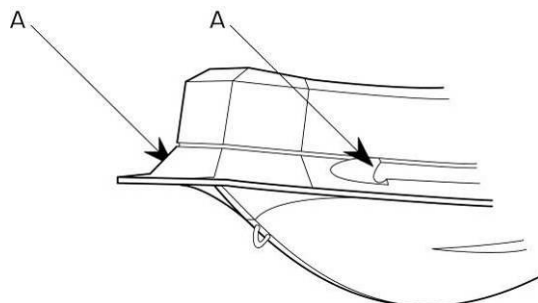

Per semplificare la procedura di montaggio del canotto, cospargere di sapone liquido (A) le guide dello scafo

2

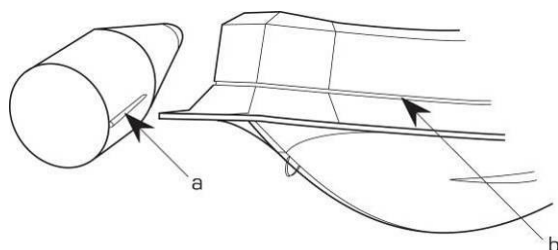

Posizionare la ralinga (a) del gommone all'interno della guida dello scafo (b) situata nella parte anteriore dello scafo. Tirare il gommone fino a portare la mini-ralinga di fronte alla guida posteriore.

3

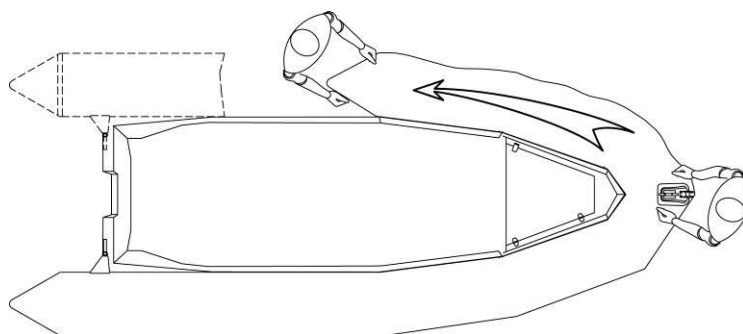

- Procedere allo stesso modo per l'altro lato del gommone.
- Far avanzare il muso del gommone per ribaltare la bavetta esterna sotto al muso dello scafo.
- Tirare di nuovo al massimo le 2 patte del gommone verso la poppa dell'imbarcazione cercando di centrare il muso rispetto alla prua dello scafo.
- Gonfiare leggermente il gommone per verificare che sia ben centrato e perfettamente adattato allo scafo. Ripetere l'operazione se il gommone non è posizionato correttamente.

## GOMMONE – Fissaggio del paraspruzzi

### II -2- FISSAGGIO DEL PARASPRUZZI

4

Fissare la bavetta esterna mediante barre di acciaio inossidabile e bulloni forniti nel kit in dotazione con il gommone. Per garantire la tenuta dell'insieme, applicare del mastice di tenuta sulle viti e nei fori dello scafo.

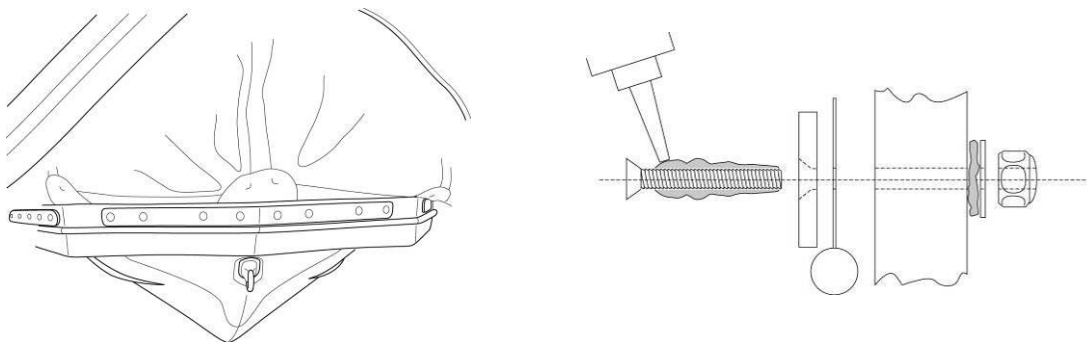

**NOTA:**

**Il montaggio del gommone sullo scafo va effettuato con gommone sgonfio.**



È possibile effettuare il gonfiaggio del gommone da smontato (pressione 240 mb) e lasciarlo stabilizzare per circa un'ora. Quindi sgonfiarlo nuovamente.



Se il gommone e' stato conservato ad una temperatura inferiore a 0°C, lasciarlo per un periodo di 12 ore in un ambiente temperato (20°C) prima di procedere alla spiegatura.

# GOMMONE – Sistema di gonfiaggio

## II-3-SISTEMA DI GONFIAGGIO

### II -3-1- Pompa ad aria

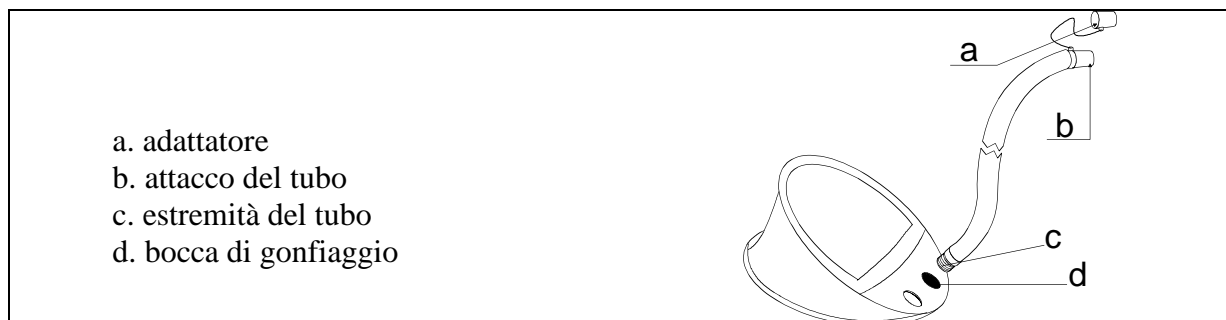

\* Una pompa ad aria elettrica (12 V) per grandi portate è disponibile come optional. (contattare il proprio rivenditore).

### II -3-2- Le valvole

#### LE VALVOLE “EASY PUSH”

Per modificare la posizione	in posizione di gonfiaggio	in posizione di sgonfiaggio
 Spingere	 La membrana è chiusa, il pulsante è in posizione sollevata	 La membrana è aperta, il pulsante è in posizione abbassata

**NOTA:**

**BISOGNA SEMPRE RIPOSIZIONARE IL TAPPO DELLA VALVOLA DOPO AVER EFFETTUATO IL GONFIAGGIO O LO SGONFIAGGIO**

## GOMMONE – Sistema di gonfiaggio

### II -3-3- L'indicatore di pressione.

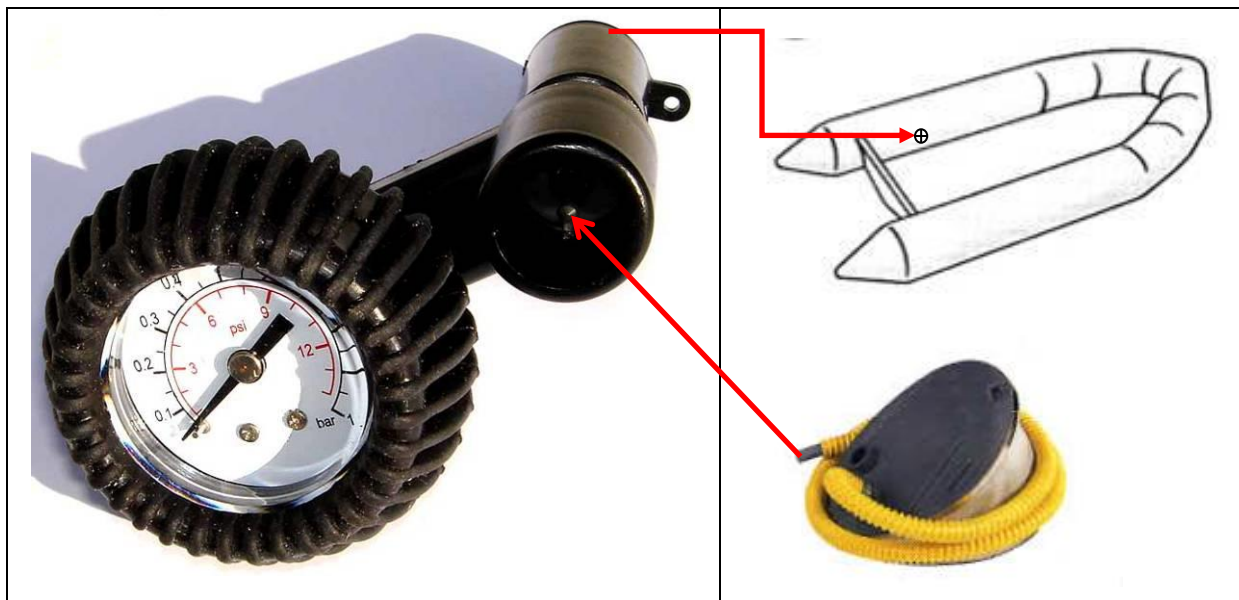

I  
T  
A  
L  
I  
A  
N  
O

### II -3-4- Gonfiaggio del gommone

#### Attivare le valvole in posizione di gonfiaggio.

Collegare la base del tubo alla bocca di gonfiaggio della pompa ad aria.  
Per un corretto gonfiaggio, la pompa ad aria deve poggiare perfettamente sul suolo.  
Il gommone si gonfia rapidamente se la pompa ad aria viene azionata delicatamente e senza fretta.

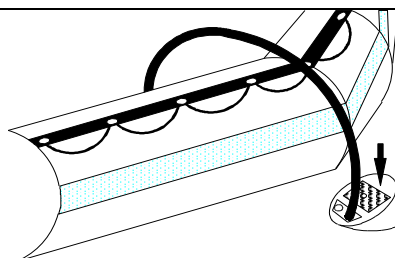

**NON UTILIZZARE COMPRESSORI O BOMBOLE AD ARIA COMPRESSA.**

# GOMMONE - Pressione

## II -4-1- Gonfiaggio del gommone

- Inserire l'adattatore corrispondente al diametro della valvola semi-incassata sull'attacco del tubo della pompa ad aria.

Procedere al gonfiaggio del gommone **equilibrando le pressioni dei diversi compartimenti, fino a quando le paratie (a) non scompaiano completamente (pressione = 240 mb)**

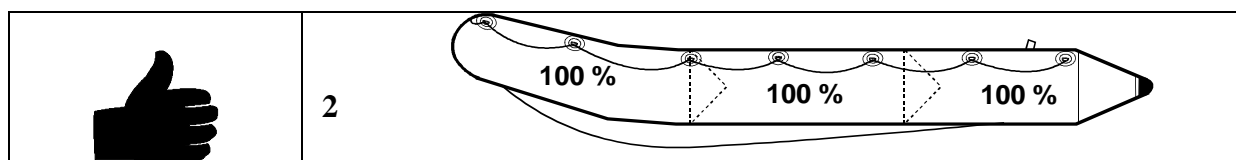
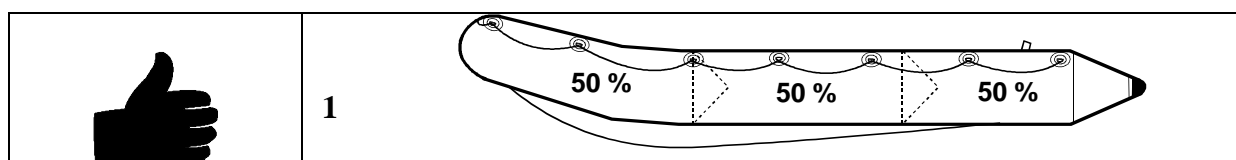
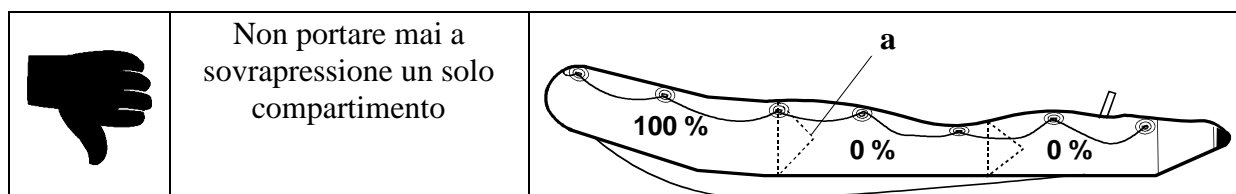

**Il gonfiaggio è ultimato:** Avvitare i tappi delle valvole di gonfiaggio.

<p><b>NOTA:</b></p>	<p><b>E' normale constatare una leggera fuga d'aria dalla valvola prima di inserire il tappo Solamente i tappi sono in grado di garantire la perfetta tenuta finale.</b></p>
---------------------	--

## II -4-2- Pressione

**La pressione d'utilizzo del gommone deve corrispondere a 240 mb/ 3,4 PSI (centro della zona verde del manometro).**

Il vostro gommone è dotato di un indicatore di pressione **ACCESS** in grado di consentire una lettura rapida ed efficace in fase di gonfiaggio (vedere le istruzioni d'utilizzo sezione "Sistema di gonfiaggio").

<p>La temperatura ambiente dell'aria o dell'acqua influisce, in modo direttamente proporzionale, sul livello della pressione interna del gommone:</p>	<p>Temperatura ambiente</p>	<p>Pressione interna del gommone</p>
	<p>+1°C</p>	<p>+4 mb / 0,06 PSI</p>
	<p>-1°C</p>	<p>-4 mb / 0,06 PSI</p>

## GOMMONE - Pressione

**Risulta altrettanto fondamentale il fatto di saper prevenire:**

**Provvedere a verificare e regolare la pressione dei compartimenti gonfiabili (rigonfiando o sgonfiando a seconda dei casi) in funzione delle variazioni di temperatura (nella fattispecie nei casi di sensibili escursioni di temperatura tra il mattino e la sera in zone particolarmente calde) e assicurarsi che la pressione non si discosti dalla zona di pressione consigliata (da 220 a 270 mb/zona verde).**

### RISCHIO DI SOTTOPRESSIONE:

**ESEMPIO:** Il vostro gommone si trova sulla spiaggia completamente esposto alla luce del sole (temperatura = 50°C) alla pressione consigliata (240 mb/3,4 PSI). Una volta immerso in acqua (temperatura = 20°C), la temperatura e la pressione interna dei compartimenti gonfiabili evidenzieranno entrambi una sensibile riduzione (sino a 120 mb), pertanto **OCCORRERA' RIGONFIARE** il gommone al fine di recuperare la pressione persa a causa dell'escursione termica verificatesi tra la temperatura ambiente e quella dell'acqua. L'eventuale diminuzione di pressione sul finire della giornata, dovuta ad un calo della temperatura esterna, sarà da considerarsi altrettanto normale.

### RISCHIO DI SOVRAPRESSIONE:

**ESEMPIO:** Il vostro gommone risulta regolarmente gonfio alla pressione consigliata (240 mb/3,4 PSI) ad inizio e fine giornata (temperatura esterna bassa = 10°C). Nel corso della giornata, il vostro gommone può essere esposto sulla spiaggia alla luce del sole o sul ponte di uno yacht (temperatura = 50°C). La temperatura interna dei compartimenti gonfiabili potrebbe, allora, evidenziare un sensibile incremento sino a raggiungere i 70°C (ciò si verifica in particolar modo con gommoni dai colori scuri), comportando un raddoppiamento della pressione originaria (480 mb). **OCCORRERA' QUINDI SGONFIARE** il gommone, al fine di raggiungere la pressione consigliata.



**ATTENZIONE**

**CON IL GOMMONE ECCESSIVAMENTE GONFIO, LA PRESSIONE SOLLECITA IN MODO ANORMALE LA STRUTTURA GONFIABILE CON IL RISCHIO DI UN EVENTUALE ROTTURA DELL'ASSEMBLAGGIO.**

### IN CASO DI SOVRAPRESSIONE

#### VALVOLA "EASY-PUSH"

Far fuoriuscire l'aria premendo il pulsante della valvola

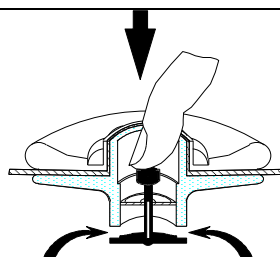



## **SISTEMA DI PROPULSIONE**

Fare riferimento alle istruzioni ZODIAC nonché alle istruzioni del fabbricante del motore per il montaggio del/i motore/i.

Per un impiego ottimale della vostra imbarcazione, siete pregati di contattare il vostro rivenditore di fiducia.

# IMPIANTO E CIRCUITO - Carburante

## IV -1-CARBURANTE

### IV -1-1-Descrizione dei principali elementi funzionali:

L'imbarcazione è dotata di un serbatoio da 400 litri, situato sotto al ponte. Il suo riempimento si effettua dalla parte anteriore dell'imbarcazione tramite un orifizio di riempimento situato sotto al cofano anteriore.

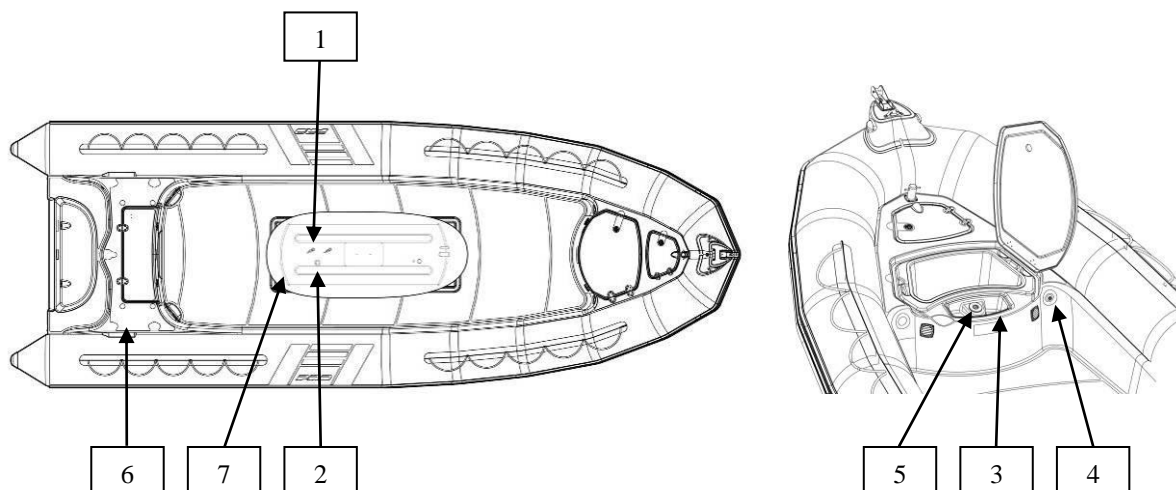

ITALIANO

RIFERIMENTO	DENOMINAZIONE
1	Valvola di chiusura benzina
2	Trasmittitore di flusso indicatore di livello
3	Alleggio di svuotamento del compartimento di "troppo pieno"
4	Sfiato
5	Bocca di riempimento
6	Filtro separatore acqua/benzina (in dotazione per il montaggio monomotore)
7	Serbatoio della benzina

 <b>ATTENZIONE</b>	<input checked="" type="checkbox"/> <b>IN CASO DI UTILIZZO MONOMOTORE, NON DIMENTICARSI DI CHIUDERE LA VALVOLA DELLA BENZINA DEL SECONDO MOTORE.</b>
--	--

### IV -2-1-Serbatoio

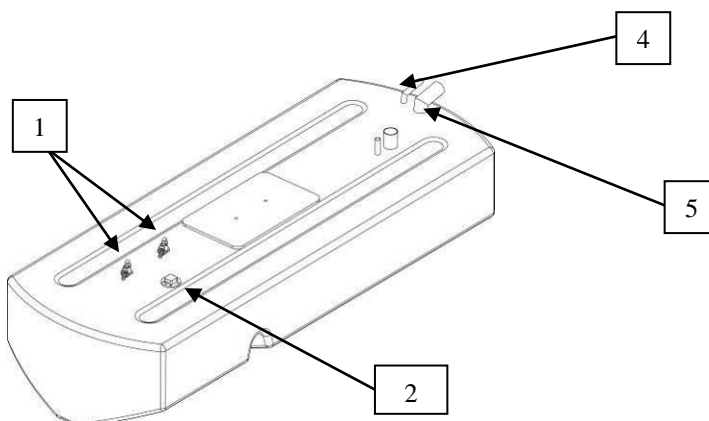

## IMPIANTO E CIRCUITO - Carburante

### IV-1-3-1 Filtro di separazione acqua / carburante

<b>NOTA:</b>	<b>Allo scopo di proteggere il motore, un filtro separatore acqua/benzina è presente sul circuito d'alimentazione della benzina del motore.</b>
--------------	---

Il filtro separatore acqua/benzina si trova nel cofano posteriore sulla parete di tribordo: (per il montaggio bimotore, contattare il proprio rivenditore per procurarsi un secondo filtro)



<b>RIFERIMENTO</b>	<b>DENOMINAZIONE</b>
1	Testa del filtro, fissata al gommone
2	Elemento di filtrazione intercambiabile

 <b>ATTENZIONE</b>	<b>SOSTITUIRE LA CARTUCCIA DEL FILTRO TUTTI 50 ORAS DE UTILIZZAZIONE</b>
-----------------------	--

# IMPIANTO E CIRCUITO - Carburante

## Sostituzione della cartuccia del filtro:

Seguire scrupolosamente le istruzioni fornite da ZODIAC, nonché le disposizioni del costruttore del filtro.

Posizionare un imbuto sotto la cartuccia da sostituire.

Prima di sostituire il filtro a cartuccia, assicurarsi che il sistema d'alimentazione della benzina non sia in pressione.

Riferirsi al manuale d'istruzioni del produttore del motore.

La benzina è una materia estremamente infiammabile. Spengere il motore, staccare la batteria e non fumare nè procedere all'istallazione del kit in prossimità di una fiamma.

Posizionare un imbuto sotto la cartuccia da sostituire

Prima di sostituire il filtro a cartuccia, assicurarsi che il sistema d'alimentazione della benzina non sia in pressione.



## IV-1-4- Utilizzo delle valvole di chiusura circuito benzina:

<b>NOTA:</b>	<b>Quando l'imbarcazione non viene utilizzata, chiudere la valvola del circuito di benzina. - Quando si intende utilizzare l'imbarcazione, aprire la valvola del circuito di benzina.</b>
--------------	---

Valvola del circuito  
benzina  
Posizione aperta

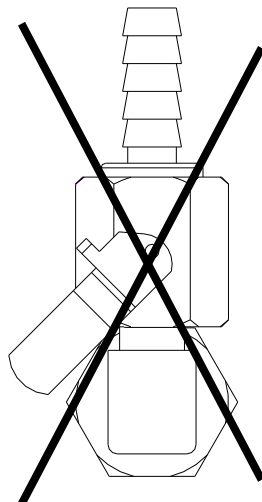
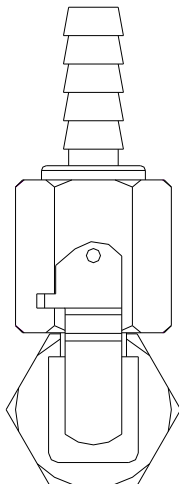



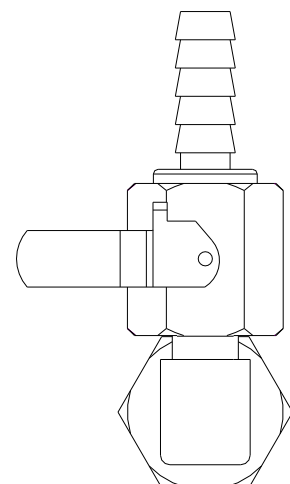

Valvola del circuito  
benzina  
Posizione chiusa



## IMPIANTO E CIRCUITO - Carburante

### IV-1-5- Avvertenze:

 <b>ATTENZIONE</b>	<p><b>IN CASO DI EVENTUALI FUGHE DI BENZINA O INCENDI, LA VALVOLA DI CHIUSURA DEL CIRCUITO D'ALIMENTAZIONE DELLA BENZINA, POSTA SUL SERBATOIO, CONSENTE D'ISOLARE IL SERBATOIO STESSO DAL CIRCUITO D'ALIMENTAZIONE DELLA BENZINA E DEVE, PERTANTO, RIMANERE CHIUSA.</b></p>
 <b>ATTENZIONE</b>	<p><b>☑ UN SERBATOIO PIENO EVITA FENOMENI DI CONDENSA IN OCCASIONE DELLE USCITE IN MARE.</b></p> <p><b>☑ PROVVEDERE ALLA PULIZIA DEL SERBATOIO OGNI 5 ANNI.</b></p> <p><b>☑ VERIFICARE IL CORRETTO SERRAGGIO DELLE FASCETTE DI OGNI SINGOLO MANICOTTO.</b></p> <p><b>☑ IN FASE DI SPURGO DEL FILTRO, PRESTARE ATTENZIONE A</b>  <b>NON FAR DEFLUIRE L'ACQUA ALL'INTERNO DEL CANOTTO. POSIZIONARE UNA VASCA DI RACCOLTA AL DI SOTTO DEL FILTRO.</b></p> <p><b>☑ PRESTARE ATTENZIONE A TOGLIERE TENSIONE PRIMA DI PROVVEDERE ALLO SMONTAGGIO DELLA CARTUCCIA DEL FILTRO.</b></p> <p><b>☑ LEGGERE ATTENTAMENTE LE ISTRUZIONI RIPORTATE SUL MANUALE DEL FILTRO.</b></p>
 <b>ATTENZIONE</b>	<p><b>☑ LA BENZINA E' ALTAMENTE INFIAMMABILE. DURANTE GLI INTERVENTI SUL SISTEMA DI CARBURAZIONE, ACCERTARSI CHE I MOTORI SIANO SPENTI.</b></p> <p><b>NON FUMARE; ALLONTANARE FIAMME O CORPI INCANDESCENTI DALLA ZONA DI LAVORO.</b></p>
 <b>ATTENZIONE</b>	<p><b>☑ NON PRATICARE MAI FORI NELLA ZONA DEL SERBATOIO CON UNA PUNTA CHE SPORGA DI OLTRE 30 MM DAL MANDRINO DEL TRAPANO (INDICATO SUL PONTE DALLA BOTOLA) E NON UTILIZZARE VITI DI LUNGHEZZA SUPERIORE A 20 MM.</b></p>





# IMPIANTO E CIRCUITO – Impianto elettrico

## IV-2-3 Ubicazione dei componenti.

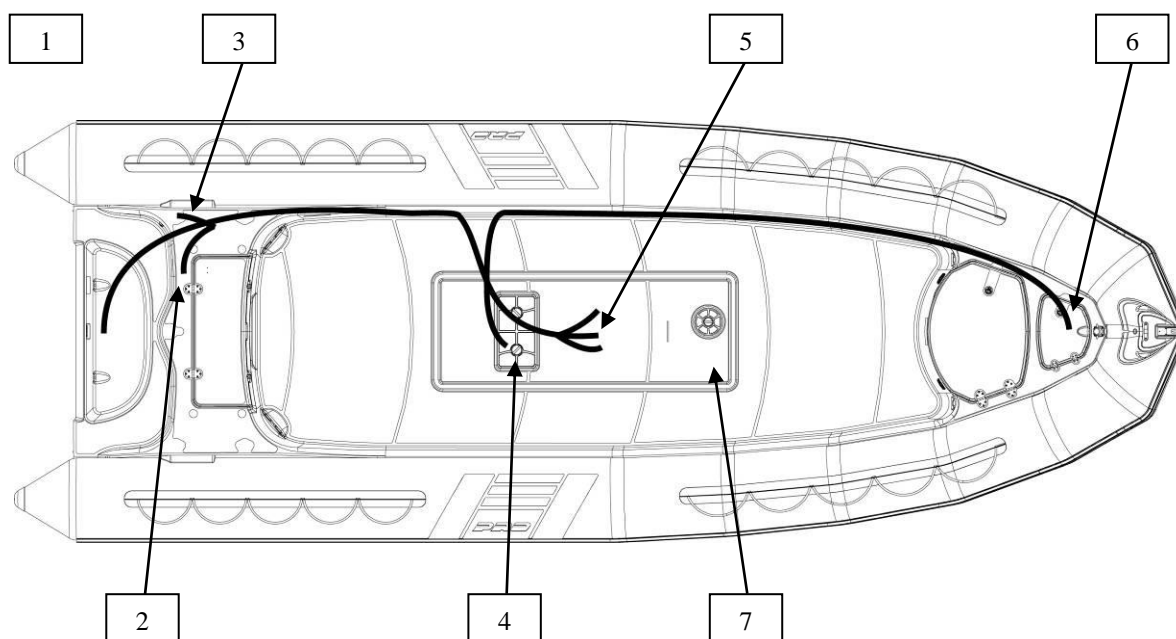

### Corrispondenze:

N° RIF.	DENOMINAZIONE
1	Alimentazione pompa di sentina
2	Supporto accoppiatori e interruttore batteria
3	Alimentazione in attesa di faro bianco
4	Indicatore di livello serbatoio
5	Cavo in attesa sotto alla botola per il cablaggio nella console
6	Alimentazione fari passacavo
7	Posizione del passacavo

## IV-2-4-Cablaggio della scatola e interruttore della console.

L'imbarcazione è dotata di un cablaggio elettrico preinstallato. Rimangono solo alcuni elementi da collegare sulla console, ossia: Il resto del cablaggio da collegare nella console si trova sotto al ponte rif. 5)

- 1 Scatola: ripartitore (bus bar + porta-fusibile)

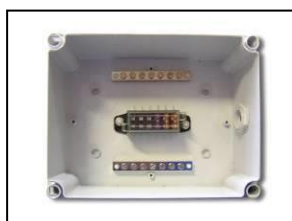



## IMPIANTO E CIRCUITO – Impianto elettrico

- Interruttori di comando dei fari + pompe di sentina (anch'essi in dotazione).

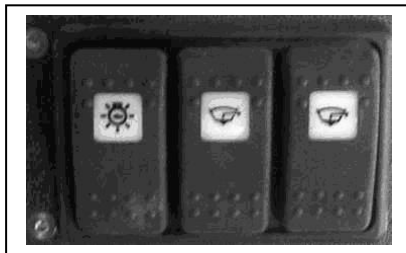

- Ricevitore dell'indicatore di livello della benzina.

### IV-2-5 Preparazione al cablaggio.

#### IV-2-5-1: Montaggio del passacavo. (in dotazione). Rif. 7

 <b>ATTENZIONE</b>	<b>DURANTE L'OPERAZIONE DI FORATURA, PRESTARE ATTENZIONE AL SERBATOIO SITUATO AL DI SOTTO.</b>
--	--

1-Forare nell'angolo.  
Rif. 7

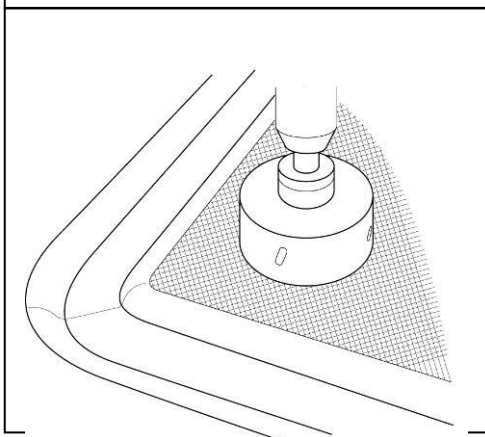

2- Recuperare i cavi elettrici del cablaggio in attesa. Rif. 5

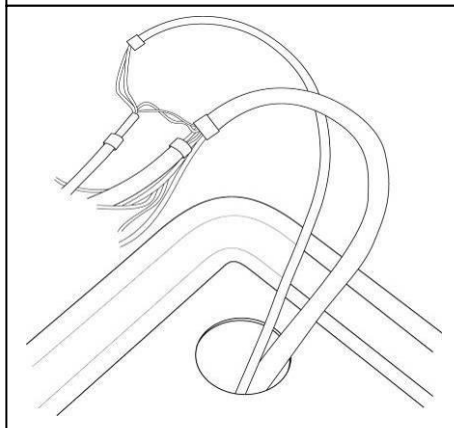

3- Posizionare la flangia per pre-forare il ponte, quindi praticare il foro.

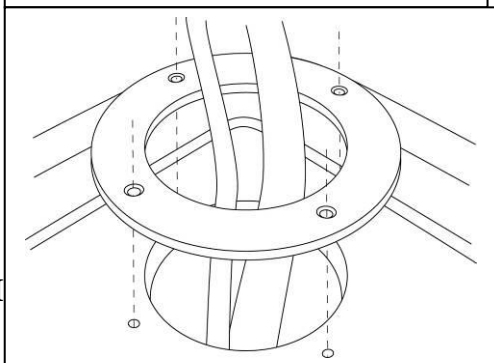

4 -Passare il passacavo e la flangia, quindi fissare il tutto sul ponte.  
(Serrare bene le viti e la parte inferiore del passacavo)

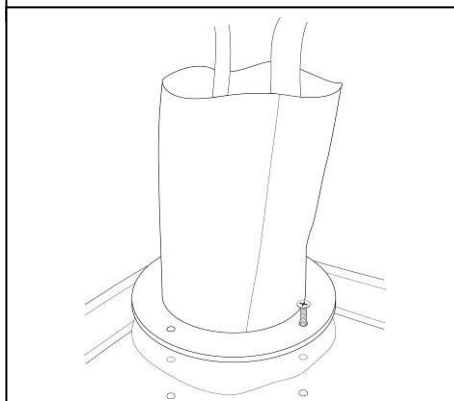

# IMPIANTO E CIRCUITO – Impianto elettrico

Dopo aver posizionato la console sul ponte e aver fatto passare i cavi attraverso il ripiano della console (in caso di console T4), procedere al cablaggio della scatola.

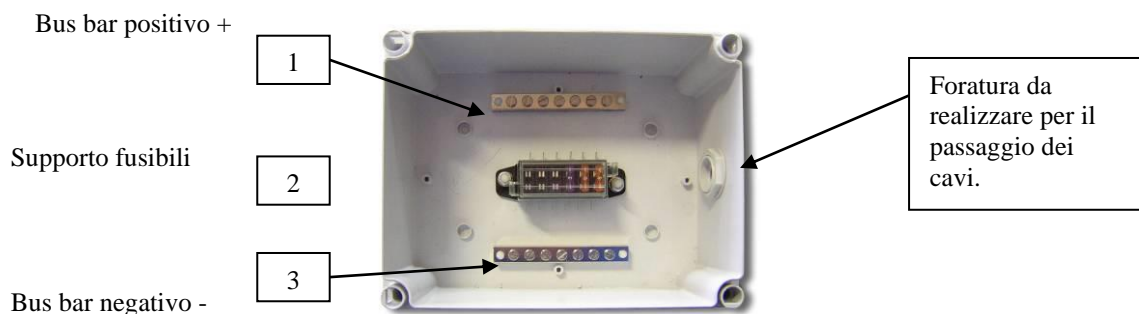

## IV-2-5-2: Cablaggio

- Fase 1: Collegare i seguenti cavi sul bus di supporto fusibile (rif. 2).

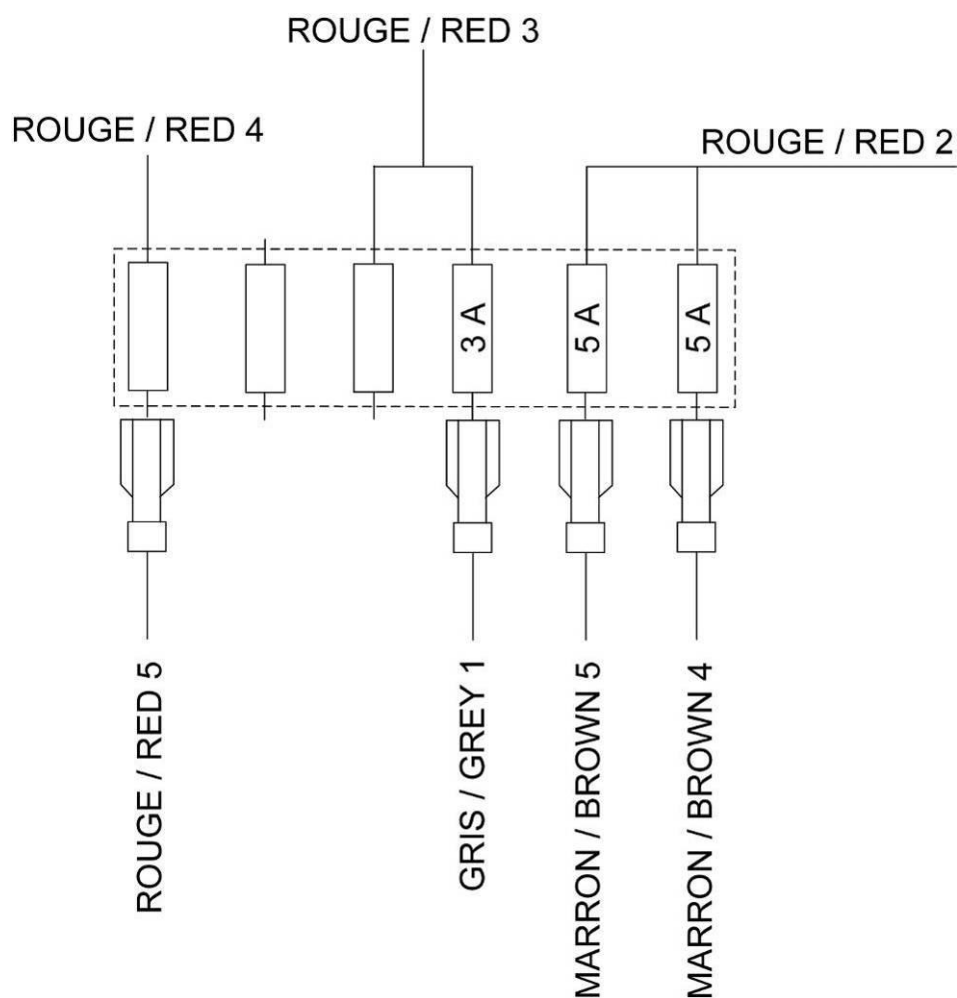

## IMPIANTO E CIRCUITO – Impianto elettrico

- Fase 2: Collegare i seguenti cavi sul bus bar negativo (rif. 3).

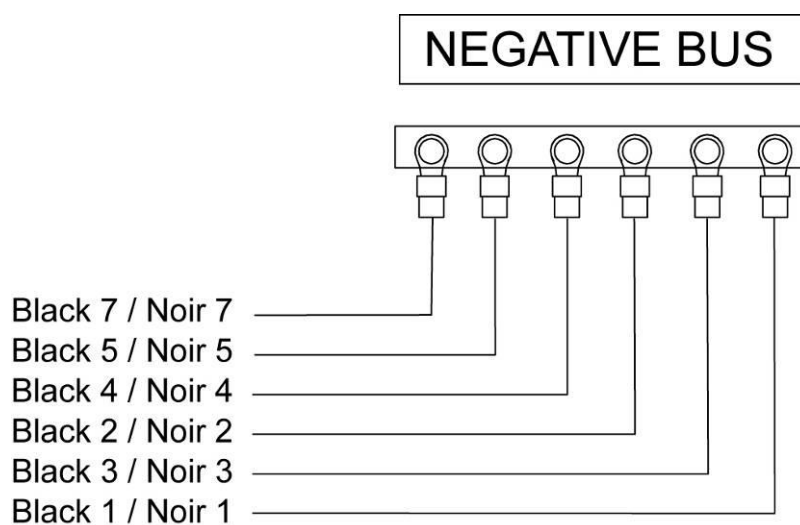

- Fase 3: Collegare i seguenti cavi sul bus bar positivo (rif. 1).

- Fase 4: Fissare la scatola sulla console.

Prima di fissare la scatola sul fianco della console, incollare una piastra di compensato per creare uno spessore su cui effettuare l'avvitamento.

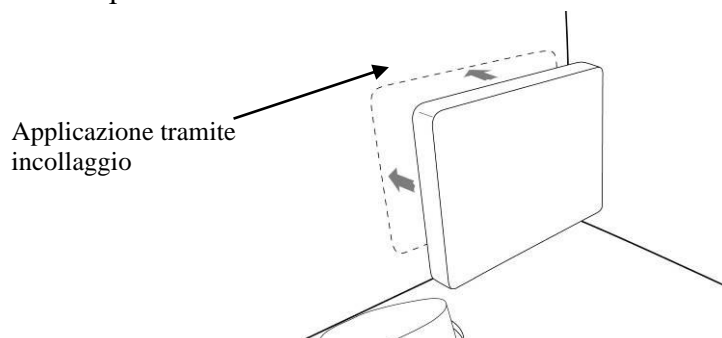

## IMPIANTO E CIRCUITO – Impianto elettrico

Fissare la scatola sulla piastra mediante viti per legno (non in dotazione)

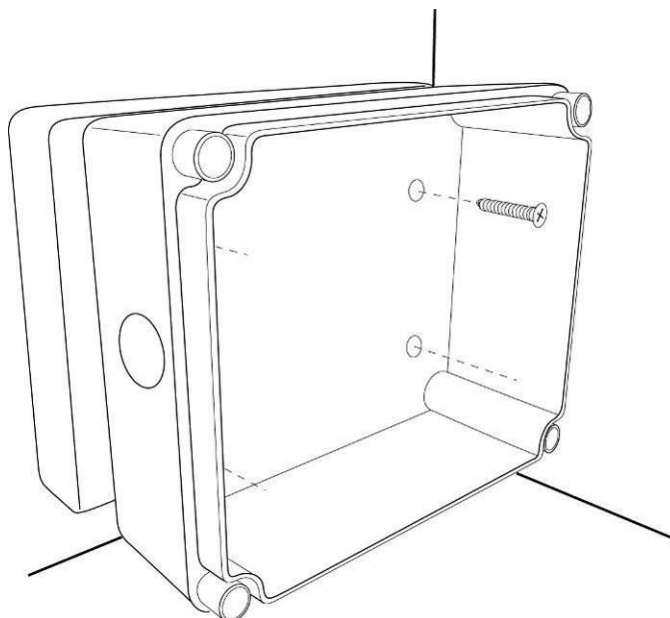

I  
T  
A  
L  
I  
A  
N  
O

### IV-2-5-3: Cablaggio degli interruttori (pompe di sentina + fari)

- Fase 1: Posizionare gli interruttori sulla console (tenendo conto della lunghezza del cablaggio elettrico).

Se si dota la propria imbarcazione di una console T4, si consiglia di posizionare il pannello degli interruttori come qui di seguito indicato.

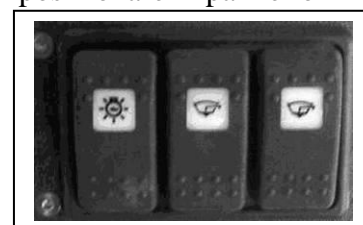
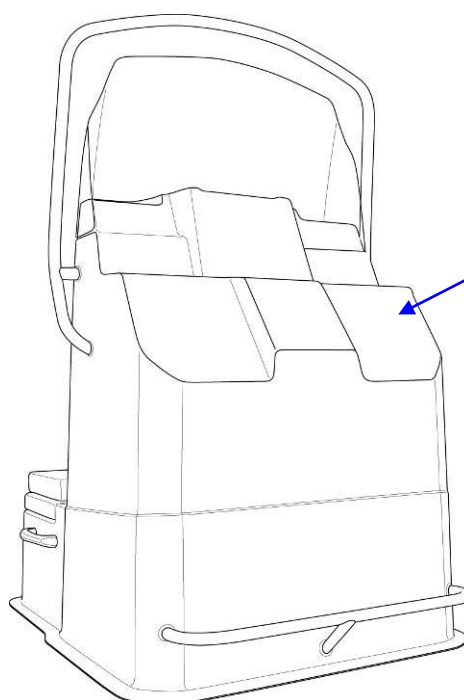

Posizionamento consigliato  
per il pannello degli  
interruttori

# IMPIANTO E CIRCUITO – Impianto elettrico

- Fase 2: Cablaggio.

Gruppo di fili da collegare

Cablaggio visto dal lato posteriore degli interruttori.

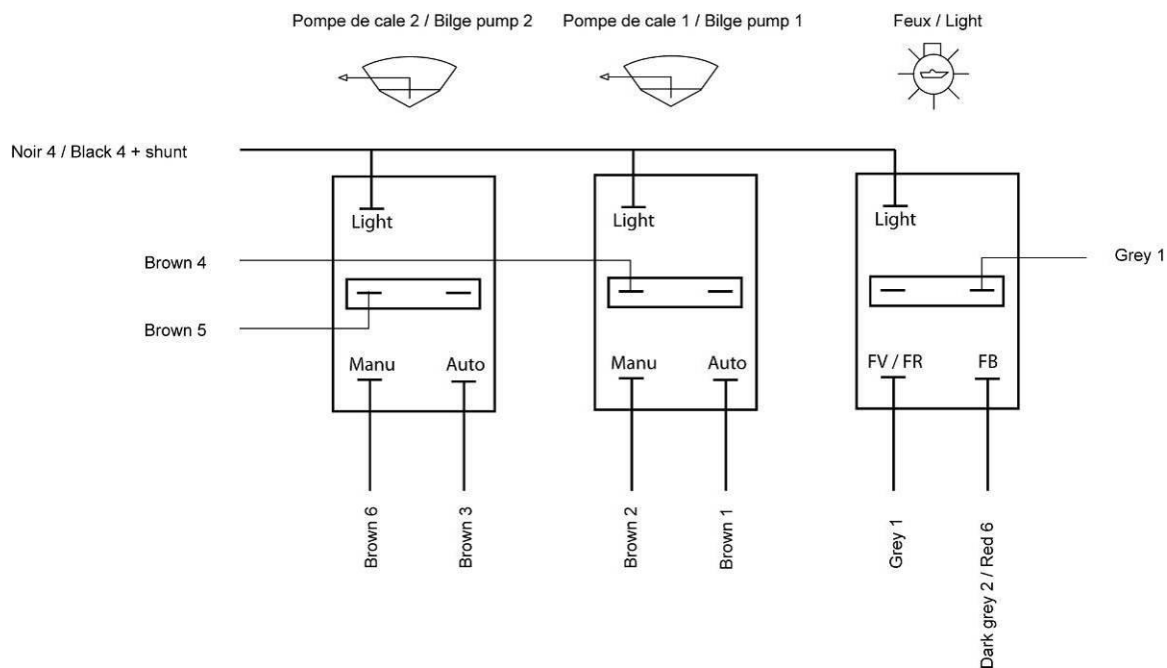

## IMPIANTO E CIRCUITO – Impianto elettrico

IV-2-5-4: Cablaggio del ricevitore dell'indicatore di livello della benzina. (Vista posteriore).

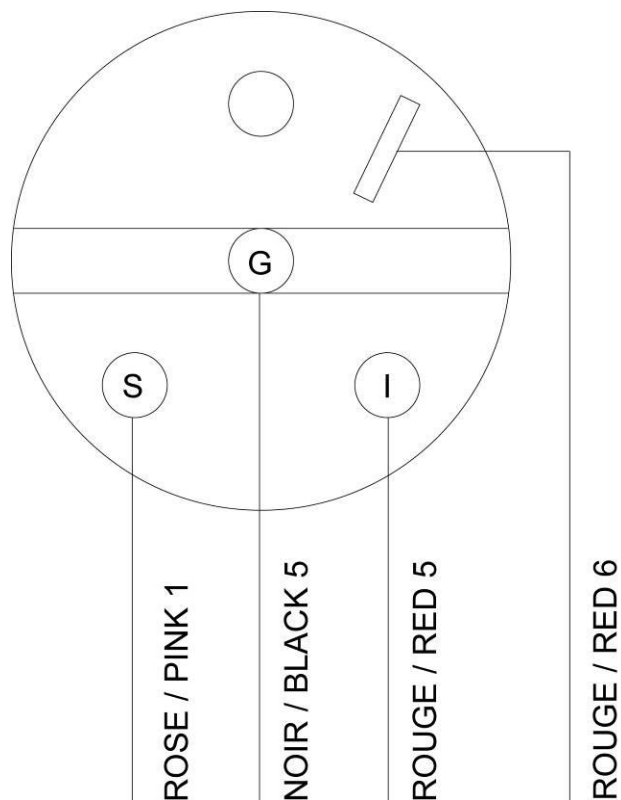

I  
T  
A  
L  
I  
A  
N  
O

IV-2-5-5:- Funzionamento interruttore di sicurezza e accoppiatori di batteria.

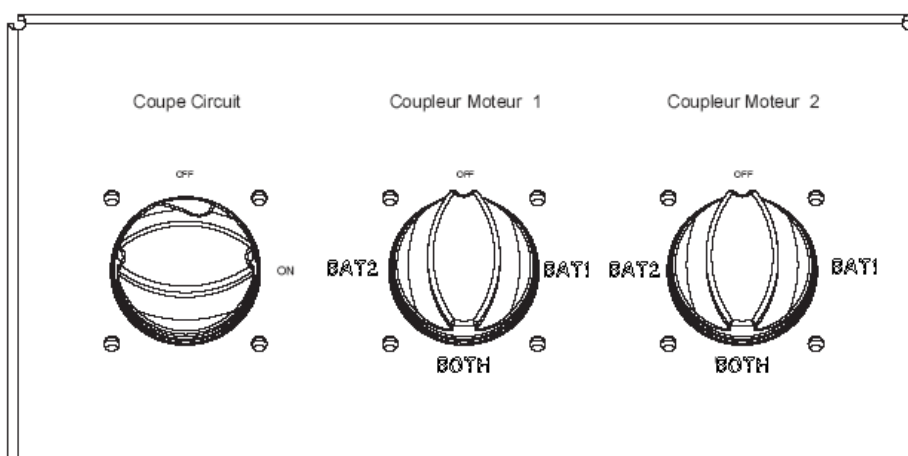

L'imbarcazione è dotata di serie di un interruttore di sicurezza e di due accoppiatori di batterie (per il montaggio bimotores).

In caso di montaggio monomotore, sarà utilizzato un solo accoppiatore.

## IMPIANTO E CIRCUITO

L'interruttore di sicurezza consente di isolare l'alimentazione della scatola della console.

<b>NOTA:</b>	Dopo ogni utilizzo, ricordarsi di posizionare l'interruttore di sicurezza su OFF.
--------------	---

Gli accoppiatori di batterie consentono di avviare i motori con una batteria per motore, ossia accoppiando le batterie (parallele), oppure di avviarli con una sola batteria.

IV-2-5-6: Tabella delle varie configurazioni possibili.

STATO ACCOPPIATORI		RISULTATO
ACCOPIATORE 1 IN POSIZIONE "OFF"	ACCOPIATORE 2 IN POSIZIONE "OFF"	<i>I MOTORI E LE BATTERIE SONO ISOLATI</i>
ACCOPIATORE 1 IN POSIZIONE "BAT 1"	ACCOPIATORE 2 IN POSIZIONE "BAT 2"	<i>OGNI MOTORE SI AVVIA CON LA PROPRIA BATTERIA CORRISPONDENTE. POSIZIONARE SEMPRE GLI ACCOPPIATORI IN QUESTA CONFIGURAZIONE</i>
ACCOPIATORE 1 IN POSIZIONE "BAT 1"	ACCOPIATORE 2 IN POSIZIONE "BAT 1"	<i>I 2 MOTORI SI AVVIANO CON LA BATTERIA 1 (nel caso in cui la batteria 2 sia difettosa)</i>
ACCOPIATORE 1 IN POSIZIONE "BAT 2"	ACCOPIATORE 2 IN POSIZIONE "BAT 2"	<i>I 2 MOTORI SI AVVIANO CON LA BATTERIA 2 (nel caso in cui la batteria 1 sia difettosa)</i>
ACCOPIATORE 1 IN POSIZIONE "BOTH"	ACCOPIATORE 2 IN POSIZIONE "BOTH"	<i>I 2 MOTORI SONO AVVIATI ACCOPPIANDO LE 2 BATTERIE</i>

# IMPIANTO E CIRCUITO – Collegamento di optional

## IV -2-6-COLLEGAMENTO DEGLI OPTIONAL

### IV-2-6-1- Avvertenze:

L'imbarcazione è dotata di serie di 2 pompe di sentina e di fari di navigazione. Rimangono tuttavia disponibili sulla morsettiera porta-fusibili (sotto alla console) 2 alloggiamenti per il collegamento di accessori supplementari nel rispetto delle seguenti condizioni:

① Gli eventuali accessori da aggiungere dovranno essere collegati a livello della console di comando.

② Gli accessori si dividono in due categorie:

**A** → gli accessori utilizzati o suscettibili di essere utilizzati in modo continuo durante il normale utilizzo dell'imbarcazione,

**B** → gli accessori utilizzati in modo discontinuo.

<b>A</b>	
Ventilatore di sentina	
Radio	
Scandagliatore	
GPS	
Riflettore	
Sistema d'allarme	
Frigorifero	
VHF	
$\Sigma$	180W max.

e

<b>B</b>	
Presenza accendi-sigaro	
Luci varie	
Avvisatore acustico	
Equipaggiamento elettronico vario	
Pompa per doccia	
Potenza massima assorbita	60W max



**E' indispensabile accertarsi che la somma delle potenze degli accessori che si intendono aggiungere, elencati nella colonna A, sia inferiore o uguale a 180W (15A) E che la potenza massima di un accessorio indicato nella colonna B sia inferiore o uguale a 60W (5A).**

**Le sezioni dei vari cavi del cablaggio elettrico sono stati calcolati in base ai suddetti valori; il mancato rispetto di tale disposizione può determinare malfunzionamenti elettrici e causare cortocircuiti.**

È possibile collegare gli optional direttamente sul bus bar positivo e negativo della console (entro i limiti di potenza massima), inserendo un porta-fusibile omologato.



## IMPIANTO E CIRCUITO – Collegamento di optional

### Esempio 1

Se si desidera aggiungere:

Una VHF da 72W,

Un GPS da 36W,

Una radio da 60W,

Un accendisigari da 72W,

Un orologio da 20W.

A	
Ventilatore di sentina	
Radio	60W
Scandagliatore	
GPS	36W
Riflettore	
Sistema d'allarme	
Frigorifero	
VHF	72W
$\Sigma$	168W (<180W ) ☺

e

B	
Luci varie	
Equipaggiamento elettronico vario	20W (orologio)
Pompa per doccia	
Potenza massima assorbita	72W (< 0 = 72W) ☺

CONCLUSIONE



### Esempio 2

Se si desidera aggiungere:

Una VHF da 60W,

Un GPS da 36W,

Una radio da 48W,

Un riflettore da 120W.

A	
Ventilatore di sentina	
Radio	48W
Scandagliatore	
GPS	36W
Riflettore	120W
Sistema d'allarme	
Frigorifero	
VHF	60W
$\Sigma$	264W (> 180W) ☹

e

B	
Luci varie	
Equipaggiamento elettronico vario	
Pompa per doccia	
Potenza massima assorbita	0 (< 60W) ☺

CONCLUSIONE



## IMPIANTO E CIRCUITO – Collegamento di optional

### Esempio 3

Se si desidera aggiungere:

Un GPS da 60W,

Una radio da 60W,

Un avvisatore acustico da 120W.

A	
Ventilatore di sentina	
Radio	60W
Scandagliatore	
GPS	60W
Riflettore	
Sistema d'allarme	
Frigorifero	
VHF	
Σ	120W (< 180W) ☺

e

B	
Luci varie	
Equipaggiamento elettronico vario	
Pompa per doccia	
Potenza massima assorbita	120W (> 60W) ☹

CONCLUSIONE



**NOTA:**

**Alcuni fabbricanti potranno indicare l'amperaggio anziché la potenza assorbita. In corrente continua (come in questo caso), è sufficiente moltiplicare per 12 per ottenere la potenza e dividere la potenza per 12 per ottenere l'intensità consumata dall'apparecchio.**

### IV-2-6-2- Cablaggio:

- ① Selezionare un alloggiamento per fusibile libero,
- ② Collegare il cavo di alimentazione del vostro accessorio sul morsetto corrispondente a tale alloggiamento mediante un "capocorda a linguetta" femmina da 6mm,
- ③ Se si desidera aggiungere del cavo di collegamento, utilizzare un cavo avente sezione minima di 1,5mm<sup>2</sup> e conforme alle raccomandazioni in materia di cavi "nautici" (UL1426 o SAE J378 o SAE J1127 o SAE J1128 o più in generale conforme alle raccomandazioni ABYC e/o CE),
- ④ Collegare il cavo di massa dell'accessorio sul terminale di massa mediante un "capocorda a occhiello" Ø5 (stessa nota come sopra per il cavo),
- ⑤ Inserire un fusibile di tipo ATO di intensità massima di 15A e superiore all'intensità di utilizzo del vostro apparecchio.

## IMPIANTO E CIRCUITO – Collegamento di optional

### IV -2-7-FUNZIONAMENTO DELLA POMPA DI SENTINA

Il funzionamento della pompa di sentina è indipendente dalla posizione dell'interruttore della batteria; l'interruttore di comando  è sempre sotto tensione.

① Funzionamento automatico (posizione fissa); in questa posizione, il funzionamento della pompa di sentina è automatico. La spia è accesa.

② Arresto; in questa posizione (posizione fissa), la pompa di sentina è ferma. La spia è spenta.

③ Funzionamento forzato; occorre mantenere premuto l'interruttore per ottenere un funzionamento forzato. Non appena viene rilasciato, l'interruttore torna in posizione di arresto (2).

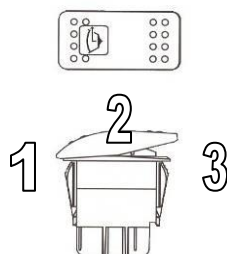

 <b>ATTENZIONE</b>	<b>IN FASE DI ORMEGGIO, POSIZIONARE L'INTERRUTTORE DELLA POMPA DI SENTINA NELLA POSIZIONE DI FUNZIONAMENTO AUTOMATICO.</b>
<b>NOTA:</b>	<b>ZODIAC CONSIGLIA DI UTILIZZARE UN TELONE O UN RAPPORTO DI ORMEGGIO AL FINE DI EVITARE LA PENETRAZIONE DI ACQUA PIOVANA.</b>

## IMPIANTO E CIRCUITO – Impianto elettrico

### IV-2-8 Batteria (non in dotazione)

Per tutti gli interventi di manutenzione ordinaria, si prega di fare riferimento alle istruzioni fornite da ZODIAC, nonché alle istruzioni fornite dal costruttore delle batterie.

	<p>PROCEDERE ALLA MANUTENZIONE della batteria:</p> <ul style="list-style-type: none"> <li><input checked="" type="checkbox"/> Mantenere la batteria perfettamente pulita e ben asciutta, al fine di evitare l'usura prematura della stessa.</li> <li><input checked="" type="checkbox"/> Provvedere al corretto serraggio e alla manutenzione dei capicorda, lubrificandoli regolarmente con vaselina.</li> </ul>
---	---

 <b>ATTENZIONE</b>	<p><b>L'ACQUA PROVENIENTE DALLA RETE DI ALIMENTAZIONE CONTIENE MINERALI CHE DANNEGGIANO LE BATTERIE. RABBOCCARE SEMPRE CON ACQUA DISTILLATA.</b></p>
 <b>ATTENZIONE</b>	<ul style="list-style-type: none"> <li>• <b>TENERE LE BATTERIE E L'ELETTROLITA FUORI DALLA PORTATA DEI BAMBINI.</b></li> <li>• <b>NON CORICARE MAI LA BATTERIA.</b></li> <li>• <b>PER AGGIUNGERE ELETTROLITA O RICARICARE LA BATTERIA, TOGLIERLA SEMPRE DAL VANO MOTORE.</b></li> <li>• <b>L'ELETTROLITA DELLA BATTERIA E' UN LIQUIDO TOSSICO E PERICOLOSO. CONTIENE ACIDO SOLFORICO CHE PUO' PROVOCARE GRAVI USTIONI. EVITARE OGNI CONTATTO CON LA PELLE, GLI OCCHI E GLI INDUMENTI.</b></li> <li>• <b>LE BATTERIE POSSONO LIBERARE GAS ESPLOSIVI. ALLONTANARE EVENTUALI FONTI DI SCINTILLE, FIAMME APERTE, SIGARETTE, ECC.</b></li> <li>• <b>CARICANDO O USANDO UNA BATTERIA, OPERARE IN UN AMBIENTE BEN VENTILATO. PROTEGGERSI SEMPRE GLI OCCHI QUANDO SI LAVORA IN PROSSIMITA' DI UNA BATTERIA.</b></li> </ul>

<b>NOTA:</b>	<ul style="list-style-type: none"> <li><input checked="" type="checkbox"/> Se si prevede di non utilizzare lo Zodiac® per un mese o più, togliere la batteria e sistemarla in un ambiente fresco, ombreggiato e asciutto. Ricaricare completamente la batteria prima di riutilizzarla.</li> <li><input checked="" type="checkbox"/> Se la batteria deve essere riposta per un periodo più lungo, verificare la densità dell'elettrolita almeno una volta al mese e ricaricare la batteria se la densità è troppo bassa.</li> </ul> <p><b>Densità dell'elettrolita: 1,28 a 20°C</b></p>
--------------	--

<b>NOTA:</b>	<p><b>Quando l'imbarcazione non viene utilizzata, posizionare l'interruttore su OFF.</b></p>
--------------	--

## IMPIANTO E CIRCUITO – Impianto di asciugamento

### IV -3-IMPIANTO DI ASCIUGAMENTO:

#### IV -3-1-Descrizione dei principali elementi funzionali:

L'imbarcazione è di tipo a scarico automatico. È dotata di 4 grandi valvole di scarico situate nella parte posteriore del ponte.

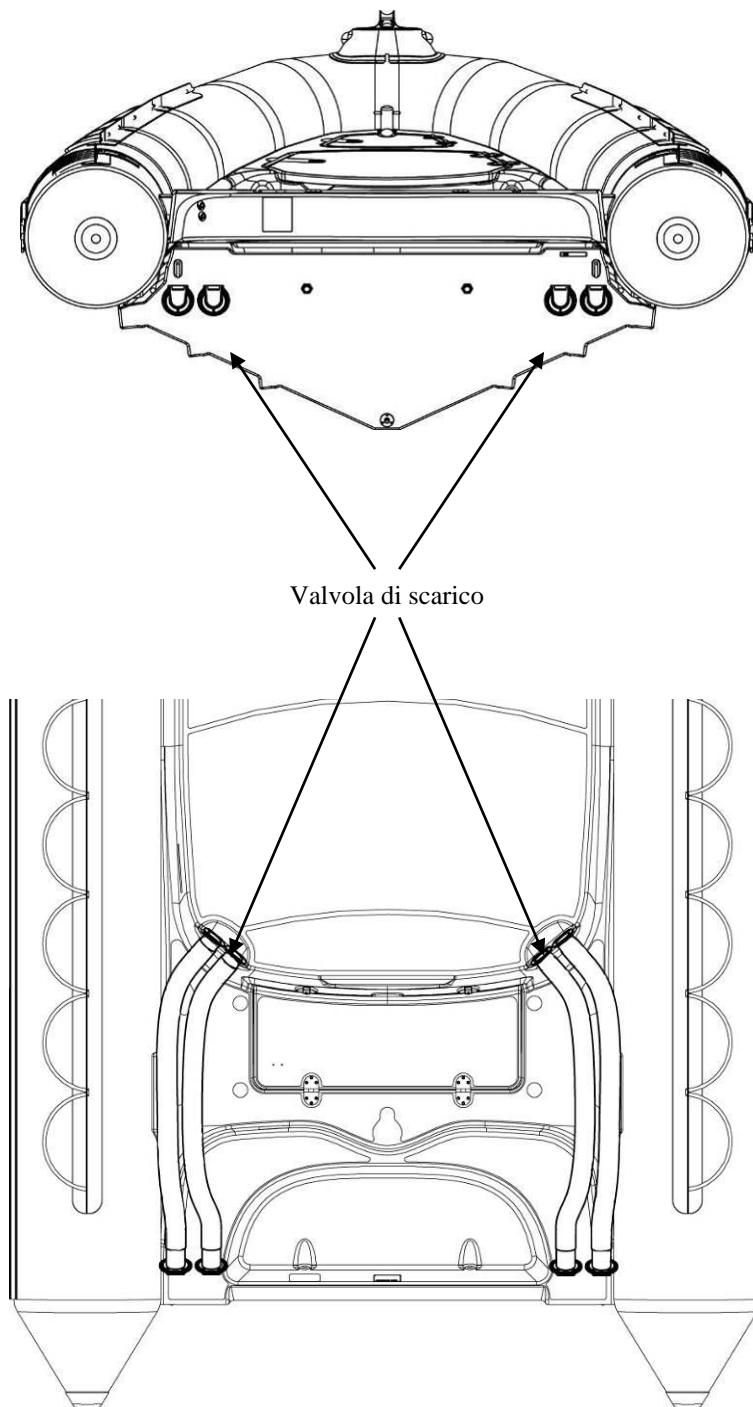

## IMPIANTO E CIRCUITO – Impianto di asciugamento

### IV-3-2-Alleggio scafo

#### IV –3-2-1-Imbarcazione a terra (rimorchio, su invasature...)

	<b>POSIZIONE APERTA, SENZA ALEGGIO.</b>
---	---

#### IV-3-2-2-Imbarcazione in acqua

	<b>POSIZIONE CHIUSA, ALEGGIO IN POSIZIONE. (ASSICURARSI CHE L’ALEGGIO SIA BEN CHIUSO)</b>
---	---

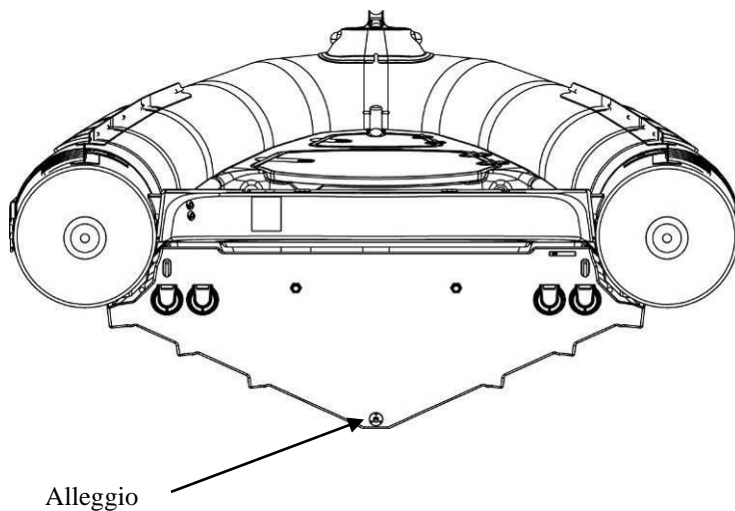

## **IMPIANTO E CIRCUITO – Sterzo**

### **IV-4-STERZO**

Per il montaggio in monomotore e, in determinati casi, in bimotores (vedi potenza massima consentita), è possibile utilizzare un martinetto idraulico (optional).

Fare riferimento alle istruzioni fornite dal costruttore dello sterzo (installazione, utilizzo e manutenzione).

Per un impiego ottimale della vostra imbarcazione, siete pregati di contattare il vostro rivenditore di fiducia.

## **IMPIANTO E CIRCUITO – Incendio**

### **IV-5- Incendio**



**ATTENZIONE**

**E' VIVAMENTE CONSIGLIATO AVERE UN ESTINTORE A BORDO, IN TUTTI I CASI SIETE PREGATI DI FARE RIFERIMENTO ALLE LEGGI IN VIGORE NEL VOSTRO PAESE.**

## IMPIANTO E CIRCUITO - Ormeggio/Ancoraggio

### IV-6-ORMEGGIO/ANCORAGGIO

#### IV -6-1-Descrizione dei principali elementi funzionali:

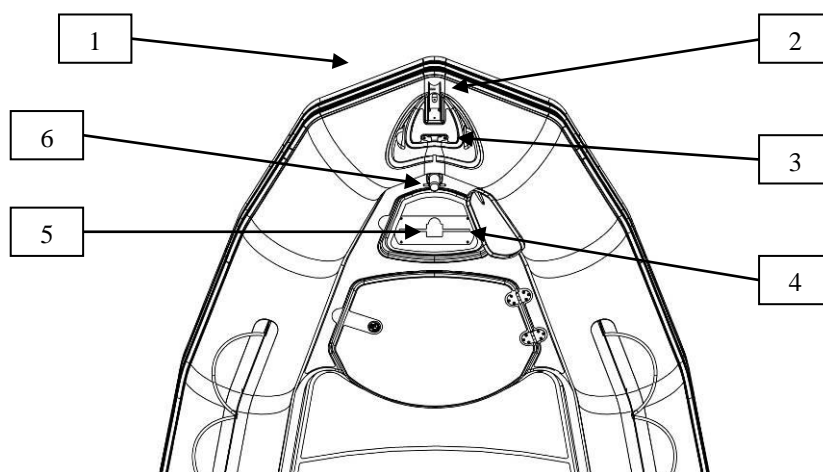

RIFERIMENTO	DENOMINAZIONE
1	Landa di prua
2	Davier + puleggia
3	Cubia
4	Gavitello d'ormeggio
5	Piastra appoggia-ancora
6	Bitta di ormeggio

#### IV-6-2- Utilizzo:

 <b>ATTENZIONE</b>	<b>LA CUBIA E LE GALLOCCE CONSENTONO SOLO UN ANCORAGGIO OCCASIONALE DELL'IMBARCAZIONE. L'ANCORAGGIO PERMANENTE DEVE ESSERE EFFETTUATO TRAMITE LA LANDA DI PRUA SITUATA SULLA PARTE ANTERIORE DELL'IMBARCAZIONE.</b>
--	---



# SEGNALETICA

## V -1-POSIZIONE DEGLI ADESIVI DI SICUREZZA E DELLE TARGHE SEGNALETICHE

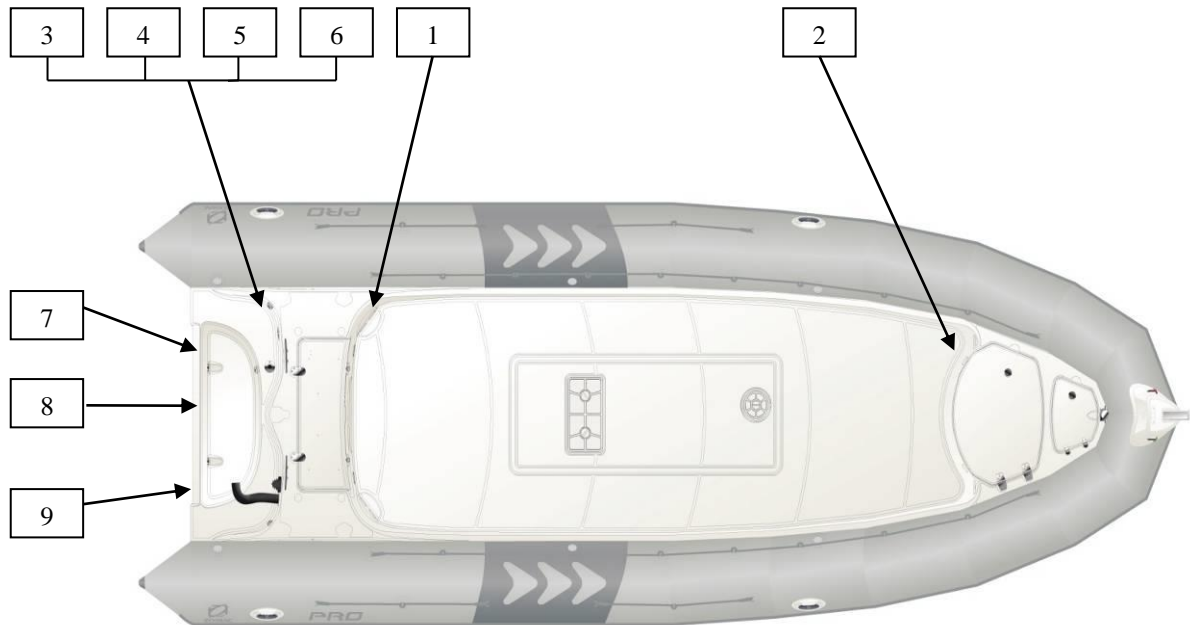

# SEGNALETICA

## V -2-DESCRIZIONE DEGLI ADESIVI DI SICUREZZA E DELLE TARGHE SEGNALETICHE



⚠ WARNING	⚠ AVERTISSEMENTS
<ul style="list-style-type: none"> <li>• DO NOT TOUCH BATTERY TERMINALS (SHOCK AND ACID HAZARDS)</li> <li>• DISCONNECT BOTH LEADS BEFORE REMOVING BATTERY</li> <li>• CONNECT RED LEAD TO POSITIVE (+) TERMINAL</li> <li>• CONNECT BLACK LEAD TO NEGATIVE (-) TERMINAL</li> </ul>	<ul style="list-style-type: none"> <li>• NE PAS TOUCHER LES TERMINAUX DE LA BATTERIE (RISQUE DE CHOC ELECTRIQUE ET DE CONTACT AVEC L' ACIDE DE LA BATTERIE)</li> <li>• DEBRANCHER LES 2 FILS DE SORTIE AVANT DE RETIRER LA BATTERIE</li> <li>• RELIER LE CABLE ROUGE A LA BORNE (+)</li> <li>• RELIER LE CABLE NOIR A LA BORNE (-)</li> </ul>

1



⚠ WARNING	⚠ AVERTISSEMENTS
<p style="text-align: center;"><b>GASOLINE IS HIGHLY INFLAMMABLE AND EXPLOSIVE</b></p> <ul style="list-style-type: none"> <li>• STOP ENGINE BEFORE REFUELING</li> <li>• REFUEL IN WELL VENTILATED AREA</li> <li>• NEVER REFUEL WHILE SMOKING, AROUND SPARKS OR OPEN FLAME</li> <li>• AVOID SPILLING FUEL. WIPE UP ALL FUEL SPILLS IMMEDIATELY</li> <li>• LEAKING FUEL IS A FIRE HAZARD AND EXPLOSION HAZARD</li> <li>• INSPECT FUEL SYSTEM BEFORE EACH USE</li> </ul>	<p style="text-align: center;"><b>L' ESSENCE EST TRES FORTEMENT INFLAMMABLE ET EXPLOSIVE</b></p> <ul style="list-style-type: none"> <li>• ARRETER LE MOTEUR AVANT TOUT REMPLISSAGE</li> <li>• NE PAS FUMER LORS DU REMPLISSAGE</li> <li>• FAIRE LE PLEIN DANS UN ENDROIT VENTILE</li> <li>• EVITER DE RENSER DU CARBURANT. ESSUYER IMMEDIATEMENT TOUTES LES FLAQUES DE CARBURANT CREEES</li> <li>• LES FUITES DE CARBURANTS CONSTITUENT UN RISQUE D' INCENDIE ET D' EXPLOSION</li> <li>• VERIFIER LE CIRCUIT CARBURANT AVANT CHAQUE UTILISATION</li> </ul>

2

⚠ CAUTION	⚠ ATTENTION
<p style="text-align: center;"><b>IMPROPERLY TOWING YOUR BOAT CAN CAUSE SEVERE DAMAGE TO YOUR BOAT.</b></p> <ul style="list-style-type: none"> <li>• NEVER TOW IN OPEN SEAS</li> <li>• NEVER TOW ABOVE 6 KNOTS</li> </ul>	<p style="text-align: center;"><b>UN REMORQUAGE INAPPROPRIE PEUT ENDOMMAGER VOTRE BATEAU</b></p> <ul style="list-style-type: none"> <li>• NE PAS REMORQUER EN PLEINE MER</li> <li>• NE PAS REMORQUER A PLUS DE 6 NOEUDS</li> </ul>

3

⚠ WARNING	⚠ AVERTISSEMENT
<p style="text-align: center;"><b>DO NOT LIFT THE BOAT WITH PASSENGERS ON BOARD</b></p>	<p style="text-align: center;"><b>NE PAS SOULEVER LE BATEAU AVEC DES PASSAGERS A BORD</b></p>

4

# SEGNALETICA

<b>⚠ DANGER</b>	<b>⚠ DANGER</b>
TO AVOID INJURY OR DEATH, SHUT OFF ENGINE WHEN NEAR SWIMMERS OR PRIOR TO USING SWIN PLATFORM AND BOARDING LADDER	POUR EVITER DES BLESSURES OU LA MORT, COUPER LE MOTEUR EN APPROCHANT DE NAGEURS, ET AVANT TOUTE UTILISATION DE LA PLATEFORME ARRIERE OU DE L' ECHELLE DE BAIN

5

<b>⚠ DANGER</b>	<b>⚠ DANGER</b>
A FIRE EXTINGUISHER MUST BE CARRIED AT ALL TIMES	UN EXTINCTEUR DOIT ETRE DISPONIBLE EN PERMANENCE A BORD

6

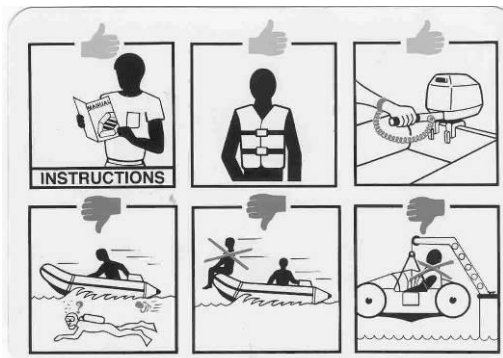

7

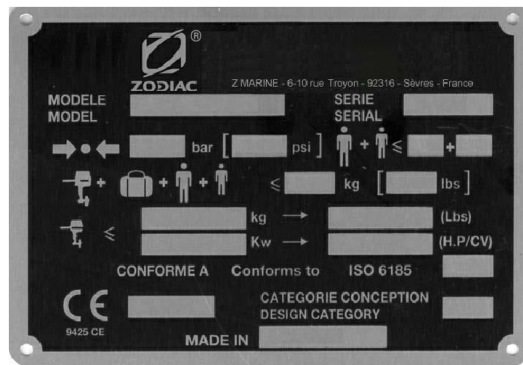

8



9

	<p><b>GARANTIRE LA PRESENZA E LA LEGGIBILITA DEGLI ADESIVI. CONTATTARE IL PROPRIO RIVENDITORE DI FIDUCIA PER PROCURARSENE DI NUOVI, SE NECESSARIO.</b></p>
--	--

## POSIZIONAMENTO DEGLI ACCESSORI OPTIONAL

**VI -1-POSIZIONAMENTO DELLA CONSOLE T4.** (A prescindere dalla categoria di navigazione B o C)

La vostra imbarcazione può essere dotata di una console optional denominata T4 (rivolgersi al proprio rivenditore Zodiac).

Al fine di ottimizzare l'utilizzo dell'imbarcazione e di usufruire di tutti gli accessi sotto al ponte (accesso serbatoio/cablaggio elettrico e passaggio dei cavi), si raccomanda di posizionarla nella zona qui di seguito specificata.

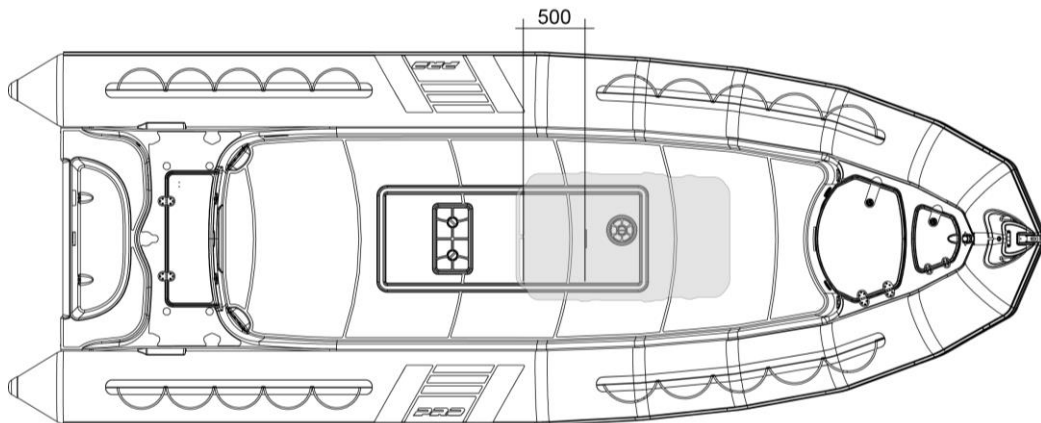

**ATTENZIONE**

**DELL'IMBARCAZIONE, IL PASSAGGIO DI CAVI (NON IN DOTAZIONE) DEVE ESSERE OBBLIGATORIAMENTE POSIZIONATO SULLA ZONA GRIGIA QUI DI SEGUITO INDICATA.**

### VI-1-2-PASSAGGIO DI CAVI:

Il passaggio di cavi e manicotti di gomma per la benzina motore è previsto sotto al ponte dell'imbarcazione. (tramite canalette preinstallate in fabbrica).

Uscita dei cavi sul ponte (tramite un passacavi).

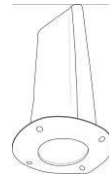

Zona di passaggio dei cavi.

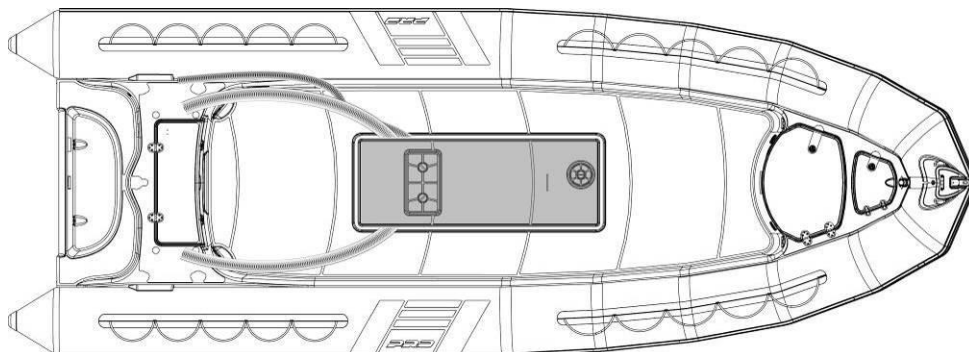

## POSIZIONAMENTO DEGLI ACCESSORI OPTIONAL

 <p>ATTENZIONE</p>	<p>PER RAGIONI DI SICUREZZA, L'APERTURA DELLA BOTOLA DI ACCESSO AL SERBATOIO DEVE RESTARE ACCESSIBILE E NON DEVE ESSERE OSTACOLATA DALLA POSIZIONE DI UN ACCESSORIO. L'APERTURA PUO' TUTTAVIA ESSERE INTERAMENTE COPERTA DALLA CONSOLE, MA RIMANERE ACCESSIBILE TRAMITE IL GAVONE DI PRUA DI QUEST'ULTIMA.</p>
---	--

 <p>ATTENZIONE</p>	<p>NON PRATICARE MAI FORI NELLA ZONA DEL SERBATOIO CON UNA PUNTA CHE SPORGA DI OLTRE 30 MM DAL MANDRINO DEL TRAPANO E NON UTILIZZARE VITI DI LUNGHEZZA SUPERIORE A 20 MM.</p>
---	---

### VI-1-3-Posizione accessori SEDILE T4 / BOLSTER T4. (a seconda della categoria di concezione)

A seconda della categoria di navigazione in cui si desidera utilizzare l'imbarcazione, sono previsti 2 posizionamenti del sedile o del bolster in base al numero di posti a sedere richiesto.

#### VI-1-3-1-categoria C.

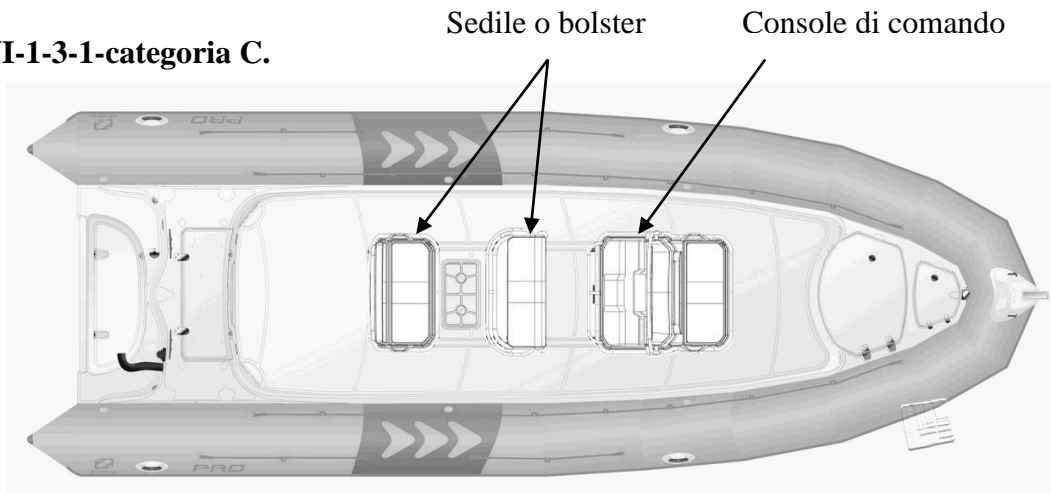

#### VI-1-3-2-categoria B. Il numero di persone in categoria B è limitato a 10; tutte le persone devono essere sedute.

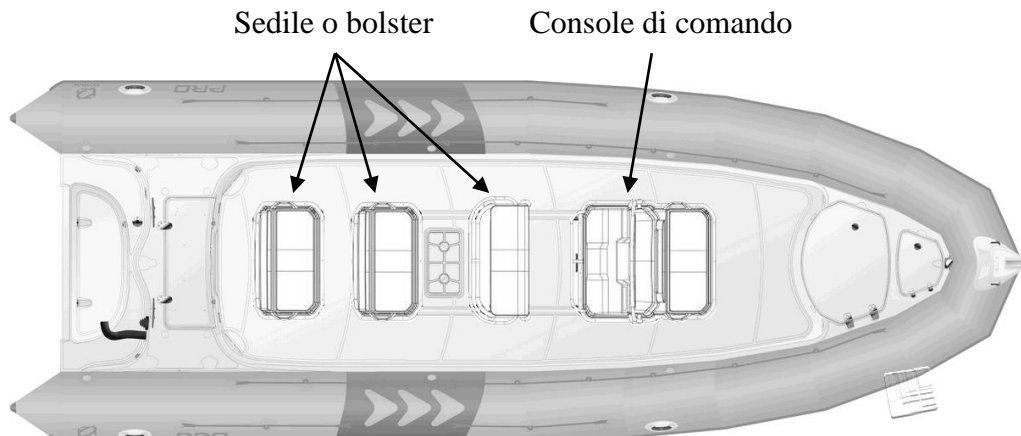

## POSIZIONAMENTO DEGLI ACCESSORI OPTIONAL

VI-1-4-Posizione accessorio ROLL-BAR. (informazioni più dettagliate sono allegate a ciascun optional).

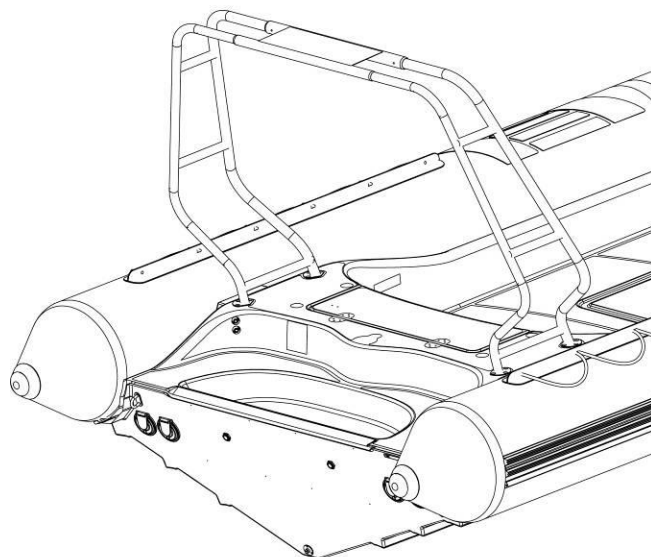

VI-1-5-Posizione accessorio asta per sci nautico / schienale posteriore.

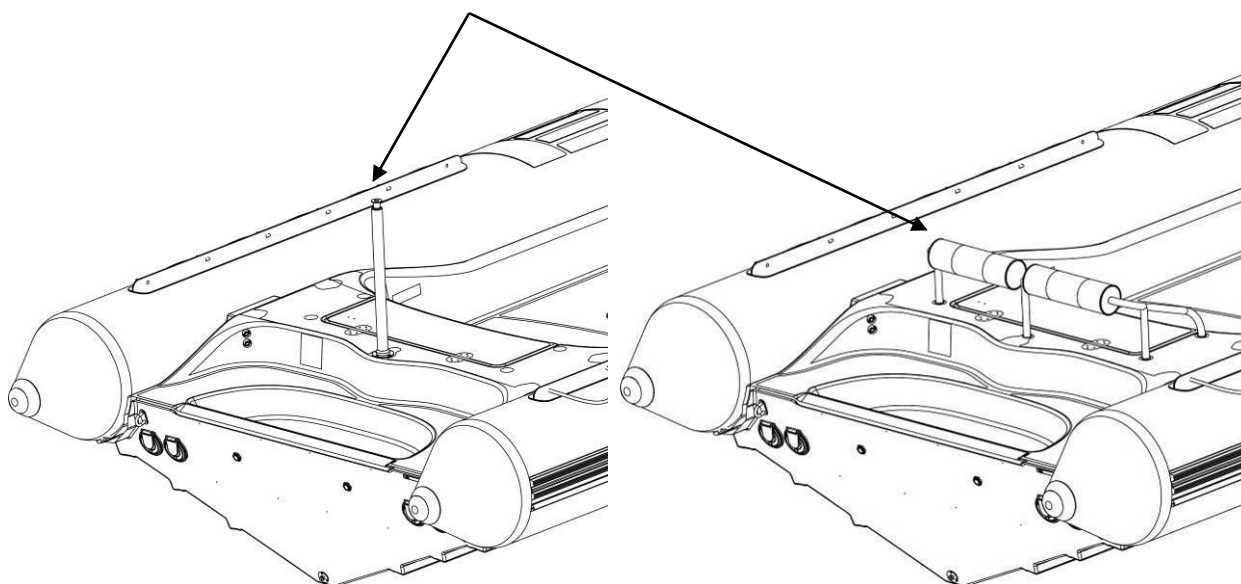

**ATTENZIONE**

**L'ASTA TRAINO SCI DEVE ESSERE USATA UNICAMENTE PER LO SCI NAUTICO. PER TRAINARE BATTELLI O CIAMBELLONI, UTILIZZATE PREFERIBILMENTE L'ANELLO DI RIMORCHIO.**

# POSIZIONAMENTO DEGLI ACCESSORI OPTIONAL

**VI-1-6-Posizione accessorio T-TOP.**

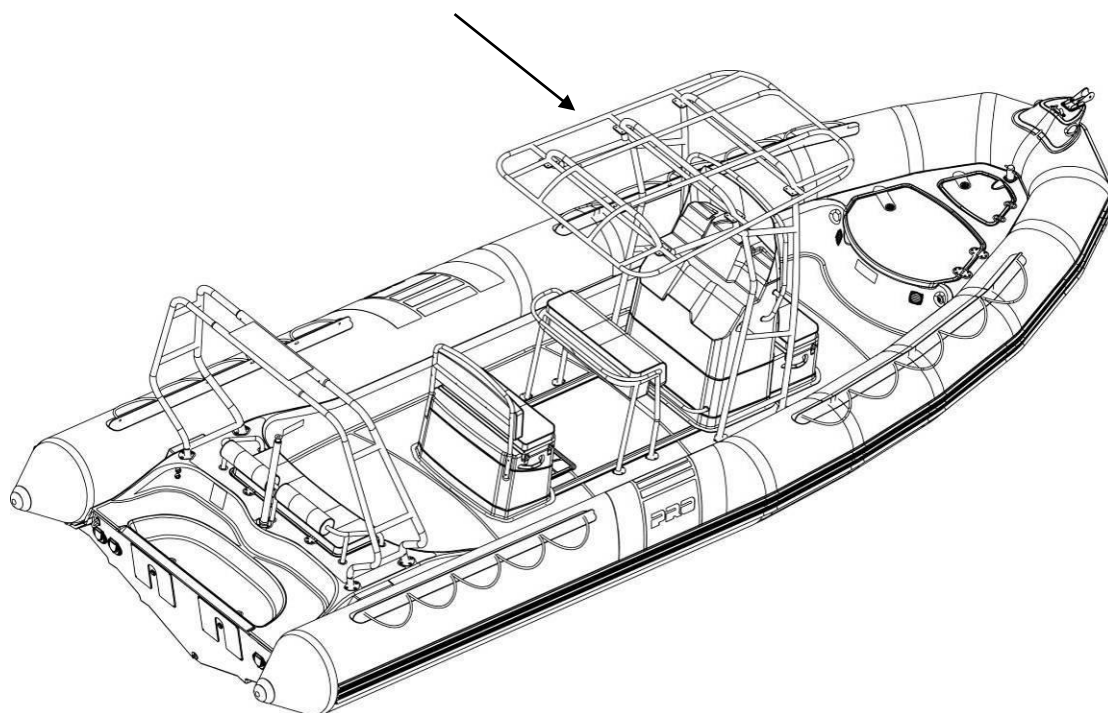



6-10 Rue Troyon  
92316- Sèvres - France

[www.zodiacmarine.com](http://www.zodiacmarine.com)

Pro 850

Code ZR20230

Edition 4





**PRO**

**PRO 850**

*Tome 2 – Volume 2*

*Teil 2 – Tomo 2*

7R20230

Edition 4



LIRE ATTENTIVEMENT CE MANUEL AVANT LA MISE EN SERVICE DE VOTRE ZODIAC.  
CAREFULLY READ THIS MANUAL BEFORE OPERATING YOUR ZODIAC.  
LEGGERE ATTENTAMENTE PRIMA DE INIZIARE IL MONTAGGIO DEL VOSTRO ZODIAC.  
VOR INBETRIEBNAHME IHRES ZODIAC VORLIEGENDES HANDBUCH AUFMERKSAM LESEN.  
LEER CUIDADOSAMENTE ESTE MANUAL ANTES DE PONER EN SERVICIO SU ZODIAC.



**Benutzerhandbuch  
Teil 2**

**PRO 850**

**TEIL 2  
BESCHREIBUNG - AUFTRIEBSKÖRPER  
ANTRIEBSSYSTEM  
EINBAU UND KREISLÄUFE**

# INHALTSVERZEICHNIS

	<b>SEITE</b>
<b>⇒ I - ALLGEMEINE BESCHREIBUNGEN</b>	
<b>I-1-Technische Daten -----</b>	<b>3 - 5</b>
<b>I-2-Technische Beschreibung-----</b>	<b>6</b>
<b>I-3-Lage der Bootsteile -----</b>	<b>7 - 8</b>
<b>I-4-Handhabung -----</b>	<b>9</b>
<b>⇒ II - AUFTRIEBSKÖRPER</b>	
<b>II-1-Montage des Auftriebskörpers am Bootsrumf-----</b>	<b>10</b>
<b>II-2-Befestigung der Schutzhülle-----</b>	<b>11</b>
<b>II-3-Aufpumpsystem-----</b>	<b>12 - 13</b>
<b>II-4-Druck -----</b>	<b>14 - 15</b>
<b>⇒ III - ANTRIEBSSYSTEM</b>	<b>16</b>
<b>⇒ IV - EINBAU UND KREISLÄUFE</b>	
<b>IV-1-Treibstoff-----</b>	<b>17 - 20</b>
<b>IV-2-Elektrik -----</b>	<b>21 - 35</b>
<b>IV-3-Lenzen-----</b>	<b>36 - 37</b>
<b>IV-4-Steuerung -----</b>	<b>38</b>
<b>IV-5-Brandschutz-----</b>	<b>38</b>
<b>IV-6-Ankern/Vertäuen -----</b>	<b>39</b>
<b>⇒ V – HINWEISSCHILDER</b>	
<b>V-1-Lage der Sicherheitsaufkleber und Kennzeichenschilder-----</b>	<b>40</b>
<b>V-2-Beschreibung der Sicherheitsaufkleber und     Kennzeichenschilder-----</b>	<b>41 - 42</b>
<b>⇒ VI – EINBAUSTELLE / MONTAGE DES OPTIONALEN     ZUBEHÖRS</b>	
<b>VI-1-Einbaustelle Konsole -----</b>	<b>43 - 44</b>
<b>VI-2-Einbaustelle Sitz / Polster-----</b>	<b>44</b>
<b>VI-3 Einbaustelle Überrollbügel-----</b>	<b>45</b>
<b>VI-4 Einbaustelle Wasserskimast / Rückenlehne -----</b>	<b>45</b>
<b>VI-5 Einbaustelle TTOP-----</b>	<b>46</b>

# BESCHREIBUNG – Technische Daten

## I-1-TECHNISCHE DATEN

Abmessungen		
	(m)	8.5
	(ft)	27'10"
	(m)	7.45
	(ft)	24'5"
	(m)	3
	(ft)	9'10"
	(m)	1.85
	(ft)	6'
	(m)	0.6
	(ft)	1'11"

Konzeptionskategorie	
(Richtlinie 94/25/CE)	B / C

Kapazität			
(ISO)		B=10	C=20
	<b>Kg</b> <sup>(1)</sup>	2050	2800
	<b>lb.</b> <sup>(1)</sup>	4519	6173
	<b>Kg</b> <sup>(2)</sup>	1350	1350
	<b>lb.</b> <sup>(2)</sup>	2976	2976
 Unterteilung		7	

Motorisierung				
Motorwellenlänge		EINMOTORIG		ZWEIMOTORIG
		XXL	XL	
	Empfohlene MINIMALE Leistung	CV <sup>(3)</sup>	250	2*175
		KW <sup>(3)</sup>	187	2*131
	Empfohlene MAXIMALE Leistung	PS	300	2*225
		kW	225	2*166
	Zugelassene, MAXIMALE Leistung	CV <sup>(3)</sup>	300	2*225
		kW <sup>(3)</sup>	225	2*166
 Maximum	MAX. Motorgewicht	Kg	393	2 x 272
		Lbs	866	2 x 600

Rumpfmaße (ohne Optionen)		
	a <sup>(4)</sup> (m)	7,78
		(ft)
	b <sup>(4)</sup>	2,27
		(ft)
	c <sup>(4)</sup> (m)	1,37
		(ft)

## BESCHREIBUNG – Technische Daten

**Auslegungskategorie:** Ihr Boot ist für Kategorie B und C gebaut und ausgelegt. Der Unterschied zwischen Kategorie B und C liegt in der zulässigen Anzahl der Passagiere und der Zuladung.

Die Kategorie B ermöglicht das Boot mit 10 Passagieren zu fahren. Jeder Passagier muß einen Sitzplatz und die Möglichkeit haben, sich festzuhalten.

Wir empfehlen Ihnen spezielles ZODIAC Zubehör zu verwenden (Fragen Sie Ihren Händler).

### Einbaustelle Zubehör SITZ T4 / POLSTER T4 (je nach Modellkategorie)

Je nach Navigationskategorie, in der Sie das Boot benutzen wollen, hier 2 Einbaustellen für Sitz oder Polster entsprechend der gewünschten Sitzplatzzahl.

#### - Kategorie C.

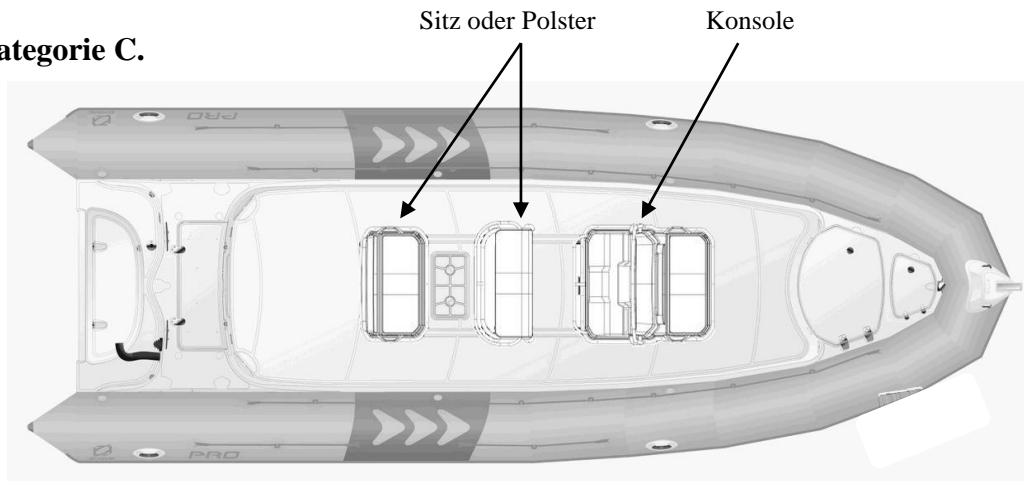

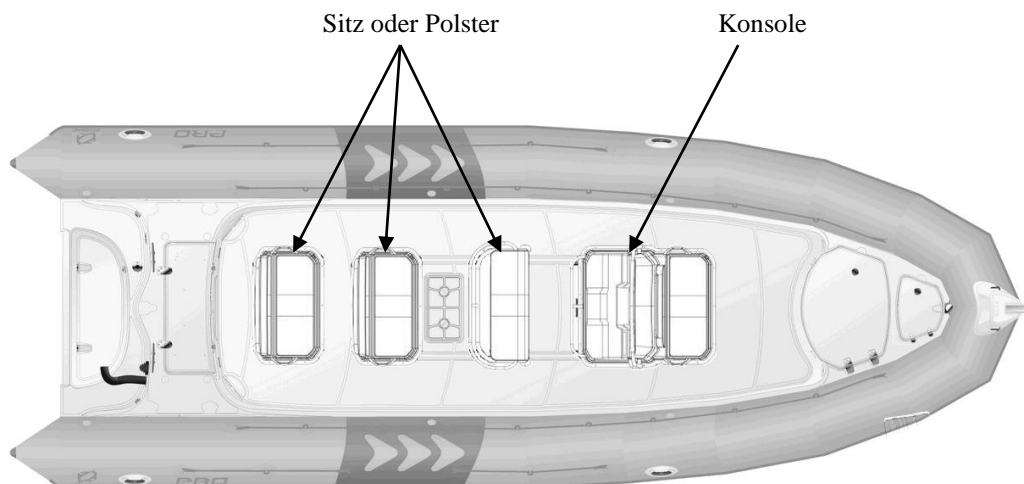

#### - Kategorie B. Die Personenzahl in Kategorie B ist auf 10 beschränkt. Alle Personen müssen einen Sitzplatz einnehmen.



<b>HINWEIS</b>	<b>Toleranz bei den Abmessungen: +/- 4%</b> <b>Gewichtstoleranzen: +/- 5%</b>
----------------	--

<b>HINWEIS</b>	<p><sup>(1)</sup> Das maximal zugelassene Gewicht wurde nach der Norm ISO 6185 berechnet. Es wird empfohlen, vorsichtig zu navigieren, wenn das Boot maximal beladen ist.</p> <p><sup>(2)</sup> Angegebene Gewichte ohne Zubehör</p> <p><sup>(3)</sup> Die empfohlenen Leistungen entsprechen einem optimalen Betrieb des Bootes bei mittlerer Last.</p> <p><sup>(4)</sup> Abmessungen des Rumpfs ohne Schlauchkörper.</p> <p>Verwenden die maximal zugelassene Leistung mit größter Vorsicht (siehe Teil 1 des Benutzerhandbuchs "Navigationsratschläge").</p>
----------------	---

 <b>ACHTUNG</b>	<p><b>DAS AUF DEM GERÄTESCHILD ANGEGEBENE HÖCHSTGEWICHT DARF NICHT ÜBERSCHRITTEN WERDEN. DAS HÖCHSTGEWICHT UMFASST MOTOR(EN), KRAFTSTOFF, ZUBEHÖR, PASSAGIERE UND DEREN MITGEFÜHRTE AUSRÜSTUNG SOWIE JEDE ANDERE ART VON LADUNG.</b></p>
--	--

 <b>ACHTUNG</b>	<p><b>LAGERN SIE IM HINTEREN BEREICH KEINE ENTZÜNDBAREN PRODUKTE. DIE LAGERUNG EINES RESERVETANKS IST STRIKT UNTERSAGT.</b></p>
---	---

**D  
E  
U  
T  
S  
C  
H**

## **REINIGUNG DES SCHLAUCHKÖRPERS**

Der Schlauchkörper dieses Bootes ist aus Hypalon™ Néoprène™ 1670 dtex .

Zur optimalen Reinigung des Schlauchkörpers empfehlen wir eine Reinigung mit Seifenwasser oder mit umweltfreundlichem Reinigungsmittel wie REVIVAL, welches beim ZODIAC Händler erhältlich ist.

 <b>ACHTUNG</b>	<p style="text-align: center;"><b>AUF KEINEN FALL REINIGER MIT LÖSUNGSMITTELN (WIE Z.B. ACETAT) VERWENDEN</b></p>
---	---

# TECHNISCHE BESCHREIBUNG

## I-2-INVENTUR

<b>BOOTSKÖRPER</b>
• Bootskörper
• Brücke geformt und rutschfest
• 1 Vorstevenring
• Ankerkasten
• 1 Verholklampen
• 1 Vertäuungsklampen
• 1 Bugkasten + herausnehmbarer Behälter (75 Liter)
• 1 Heckkasten
• 2 Rüsteisen
• 1 Rumpfwasserklappe
• Schnellentleerung mit großem Durchfluss
• 1 400-Liter-Tank
• 1 Trennfilter Wasser/Benzin
• 1 Zugangsklappe Absperrventile / Benzinkreislaufanzeige
• 1 Zugangsklappe Benzinschläucheanschluss
• Stromkreis mit Batteriekoppler und Schutzschalter
• 2 Lenzpumpen
<b>AUFTRIEBSKÖRPER</b>
• Abnehmbarer Auftriebskörper aus STRONGAN DUOTEX 2 X 1100 Decitex
• 7 halb eingelassene Ventile „easy-push“
• Reibungsschutz mit breitem Profil
• 4 externe Griffe
• 2 Patches
• Schlingengriffe
• Kurze Kegelstümpfe
• 1 Seilrollenhalterung + Seilrolle + Klampe + Navigationslichter
<b>STANDARDAUSRÜSTUNG</b>
• 2 Paddel
• Fußblasebalg
• Manometer
• Reparaturkoffer
<b>ZUBEHÖR ALS OPTION</b>
• Konsole T4
• Sitz T4
• Polster
• Rückenlehne
• Wasserskimast
• Überrollbügel
• T Top
• Badeleiter
• Halter für 4 und 6 Flaschen
• Elektrischer Blasebalg.

\* Wegen zusätzlicher Informationen über das verfügbare optionale Zubehör wenden Sie sich bitte an Ihren ZODIAC-Händler.

# BESCHREIBUNG – Funktionelle Bauteile

## I-3-LAGE DER BOOTSTEILE

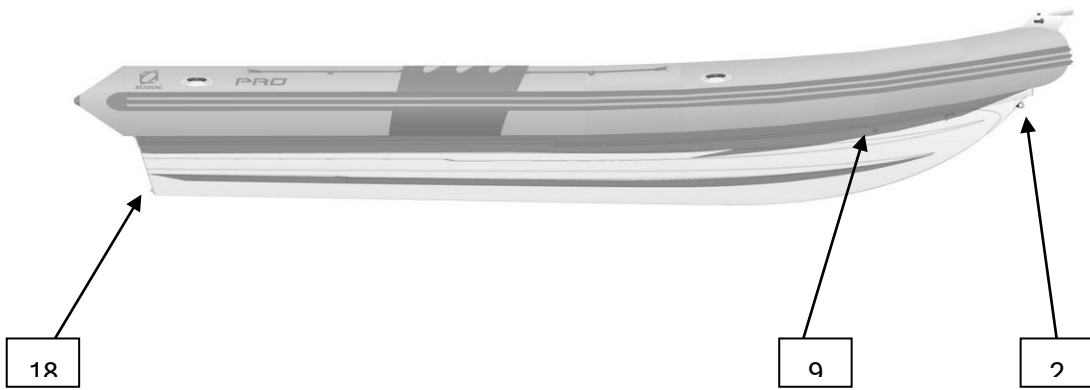
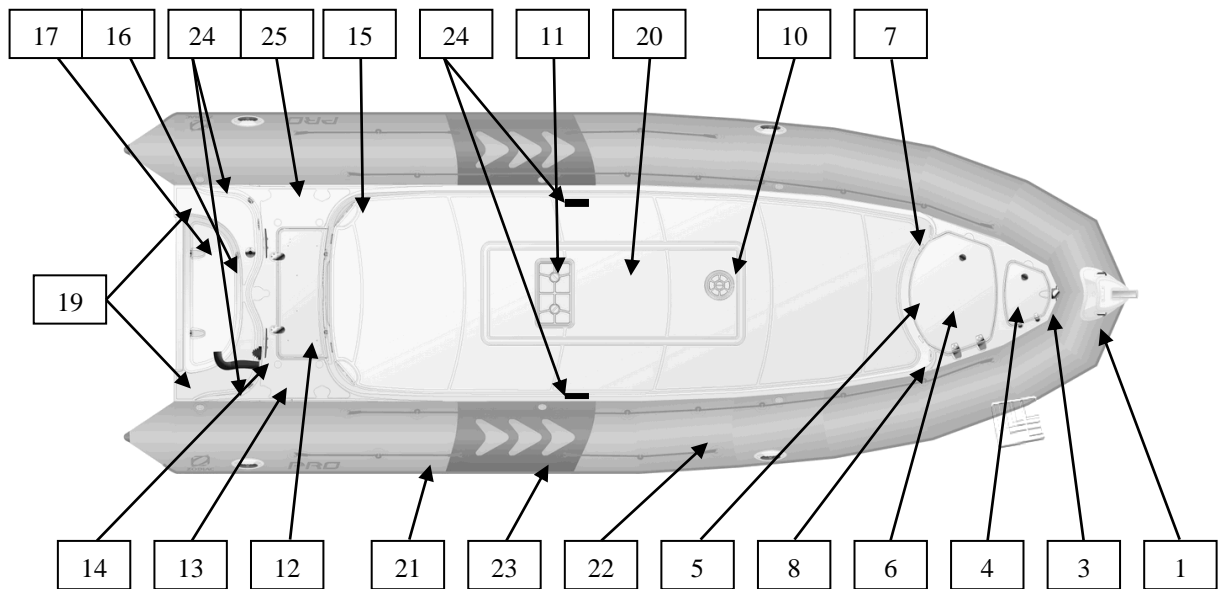

D  
E  
U  
T  
S  
C  
H



## BESCHREIBUNG – Funktionelle Bauteile

KENNZ.	BEZEICHNUNG
1	Seilrollenhalterung + Seilrolle + Klampe + Navigationslichter
2	Vorstevenring
3	Vertäuungsklampe
4	Abdeckung Ankerkasten
5	Tankeinfüllstutzen
6	Herausnehmbarer Behälter 75 Liter
7	Lüftungsgitter Tankabteil
8	Tankentlüftung
9	Benzinauslass
10	Zugangsklappe Tankeinfüllstutzen
11	Zugangsklappe Absperrventile / Benzinkreislaufanzeige
12	Heckhaube
13	Abscheider Wasser / Benzin
14	Motorkabeldurchführung
15	Schnellentleerung mit großem Durchfluss
16	Heckbehälter
17	Behälterentleerungsöffnungen
18	Rumpfentleerungsöffnung
19	Hintere Rüsteisen
20	Tank
21	Auftriebskörper
22	Festhalteleine
23	Logos Pro
24	Rückseitige Leiste
25	Steckplatz für Beleuchtung

# BESCHREIBUNG - Handhabung

## I-4-HANDHABUNG

### I-4-1-Transport:

- Die Empfehlungen für Anhängerverladung sind im Besitzerhandbuch, TEIL I, genau angeführt.

### I-4-2-Lagerung:

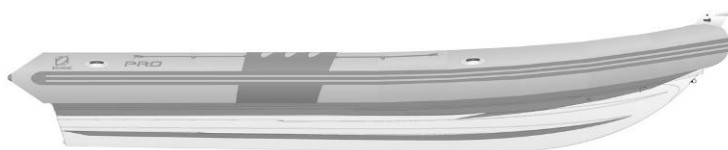

 <b>ACHTUNG</b>	<b>DAS BOOT MUSS UNBEDINGT AUF DER          VORSTEVENLINIE AUFLIEGEN (SIEHE SKIZZE UNTEN).</b>
---	--

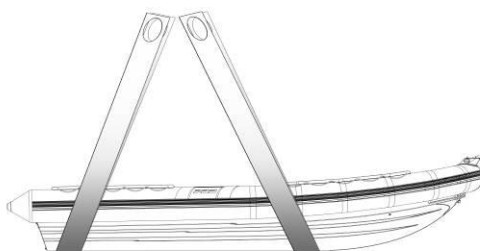

### I-4-3-Heben: Das Boot besitzt keine Hebevorrichtungen.

 <b>WARNUNG</b>	<b>DA DAS BOOT KEINE HEBEVORRICHTUNGEN          BESITZT, MUSS DER HEBEVORGANG ZWINGEND MIT          GEEIGNETEN, UNTER DEM RUMPF          DURCHGEZOGENEN HEBERIEMEN DURCHGEFÜHRT          WERDEN.          BITTE WENDEN SIE SICH FÜR DIESEN VORGANG AN          HEBESPEZIALISTEN.</b>
---	--



 <b>ACHTUNG</b>	<b>BEIM VERLADEN MIT DEM KRAN DARF NIEMAND AN          BORD SEIN</b>
 <b>WARNUNG</b>	<b>DAS BOOT MUSS BEI DER KRANVERLADUNG VÖLLIG          LEER SEIN.           VOR ZUWASSERLASSEN DES BOOTS          RUMPFENTLEERUNGSÖFFNUNG (18) ÖFFNEN, UM          EVENTUELLES REGENWASSER AUS DEM COCKPIT          ABZULASSEN (ÖFFNUNG VOR ZUWASSERLASSEN          WIEDER SCHLIESSEN)</b>

# AUFTRIEBSKÖRPER - Montage des Auftriebskörpers auf den Bootsrumpf

## II-1-MONTAGE DES AUFTRIEBSKÖRPERS AUF DEN BOOTSRUMPF

1

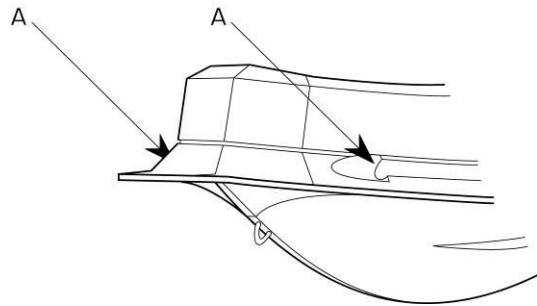

Um den Einbau des Auftriebskörpers zu erleichtern, tragen Sie flüssige Seife (A) in den Schienen des Bootsrumpfes auf

2

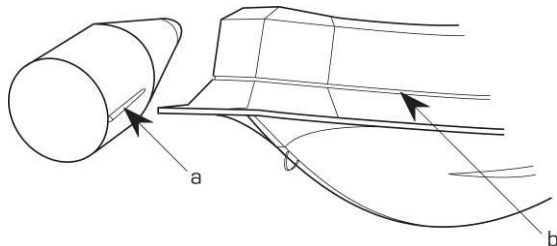

Positionieren Sie die Randversteifung (a) des Auftriebskörpers in der Schiene des Bootsrumpfes (b) vorne am Bootsrumpf. - Ziehen Sie den Auftriebskörper so, dass die Leine der hinteren Schiene gegenüber liegt.

3

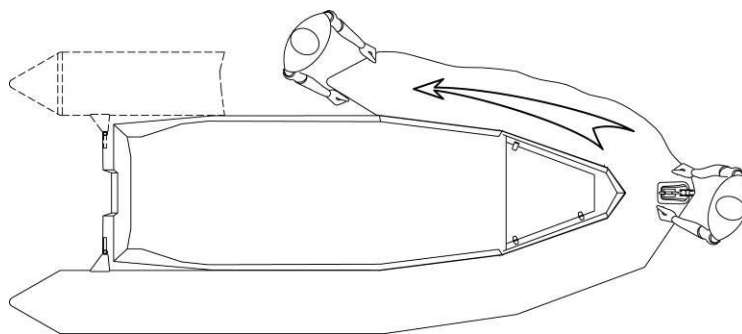

- Gehen Sie auf die gleiche Art und Weise für die andere Seite des Auftriebskörpers vor.
- Das Vorderteil des Auftriebskörpers vorschieben, damit die äußere Dichtungsschürze am Bug des Bootsrumpfes umgeschlagen werden kann.
- Ziehen Sie erneut die beiden Laschen des Auftriebskörpers so weit wie möglich ans Bootsende und versuchen Sie, das Vorderteil in Bezug auf den Bug des Bootsrumpfes zu zentrieren.
- Den Vorderteil des Auftriebskörpers leicht aufblasen, um zu überprüfen, ob er richtig zentriert ist und einwandfrei auf dem Bootsrumpf sitzt. Den Montagevorgang nochmals durchführen, wenn der Auftriebskörper nicht einwandfrei sitzt.

# AUFTRIEBSKÖRPER – Befestigung der Schutzhülle

## II -2- BEFESTIGUNG DER SCHUTZHÜLLE

4

Äußere Schutzhülle mit Hilfe von Inox-Leisten und Schrauben aus dem mitgelieferten Auftriebskörper-Bausatz befestigen. Um die Dichtigkeit sicherzustellen, Dichtungsmasse auf Schrauben und in Rumpflöchern verteilen.

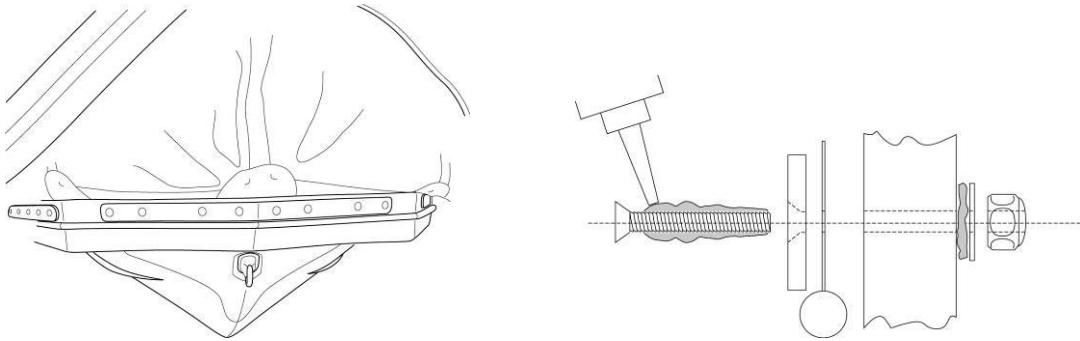

**HINWEIS:**

**Die Montage des Auftriebskörpers auf den Bootsrumf erfolgt bei unaufgepumptem Auftriebskörper.**



Sie können den nicht montierten Auftriebskörper aufpumpen (Druck 240 mb) und ihn ca. eine Stunde « ruhen » lassen. Lassen sie dann die Luft wieder raus.



Wurde der Auftriebskörper bei einer Temperatur unter 0°C gelagert, bewahren Sie ihn 12 Stunden bei Raumtemperatur auf (20°C), bevor Sie ihn entfalten.

# AUFTRIEBSKÖRPER - Aufpumpsystem

## II-3-AUFPUMPSYSTEM

### II -3-1- Blasebalg

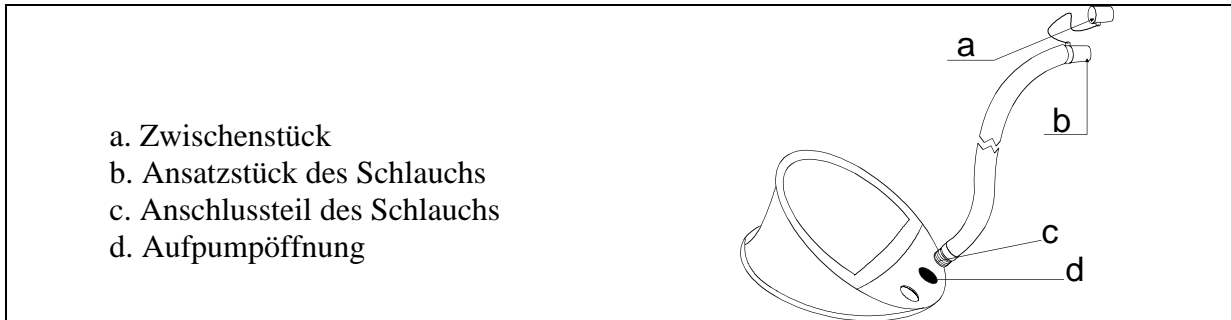

\* Ein elektrischer Blasebalg (12 V) mit großem Luftvolumen ist als Option erhältlich. (sprechen Sie Ihren Händler an).

### II -3-2- Ventile

#### EASY PUSH VENTILE

Um die Position zu ändern	Aufpumpposition	Entleerungsposition
 Drücken	 Die Membrane ist geschlossen, der Druckstift in oberer Stellung	 Die Membrane ist geöffnet, der Druckstift in unterer Stellung

**HINWEIS:** NACH DEM AUFPUMPEN BZW. ENTLEREN MÜSSEN SIE DEN VENTILVERSCHLUSS STETS AUFSETZEN

# AUFTRIEBSKÖRPER - Aufpumpsystem

## II -3-3- Druckanzeige

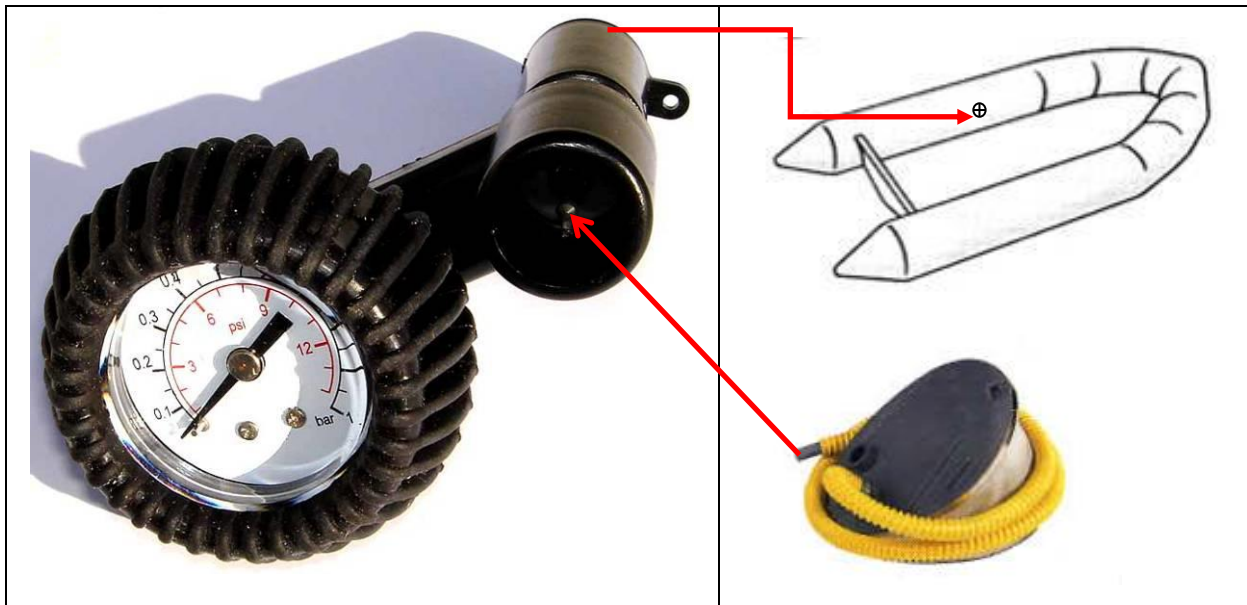

## II -3-4- Aufpumpen des Auftriebskörpers

**Drehen Sie alle Ventile in die Stellung  
Aufpumpen.**

Stecken Sie das Anschlussstück des Schlauches in die Aufpumpöffnung des Blasebalgs. Damit Sie Ihr Boot leicht aufpumpen können, muss der Blasebalg einwandfrei auf dem Boden aufliegen. Das Boot wird schnell aufgepumpt, wenn der Blasebalg weich und nicht zu schnell betätigt wird.

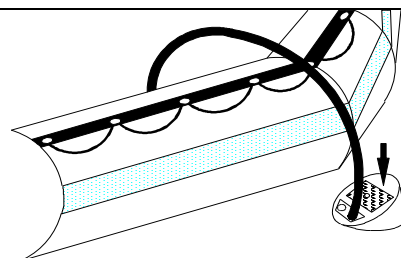

**WEDER KOMPRESSOR NOCH DRUCKLUFTFLASCHE  
VERWENDEN.**

# AUFTRIEBKÖRPER - Druck

## II -4-1- Aufpumpen des Auftriebkörpers

- Das entsprechende Zwischenstück für den Durchmesser des halbeingelassenen Ventils auf das Ansatzstück des Blasebalgschlauchs aufstecken.

Den Auftriebskörper aufpumpen, **indem die Drücke in den verschiedenen Abteilen gleichmäßig verteilt werden, bis die Trennwände (a) nicht mehr sichtbar sind (Druck = 240 mb)**

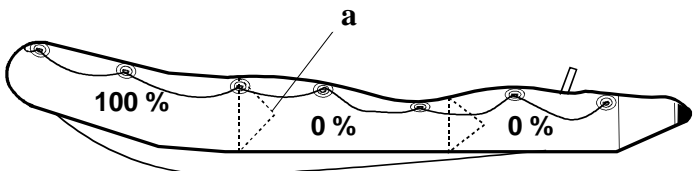
	<p>Niemals ein Abteil unter Druck setzen, wenn die anderen vollkommen luftleer sind</p>	
---	---	--

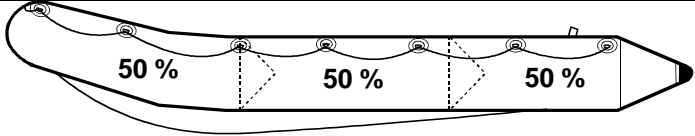
	<p>1</p>	
--	----------	---

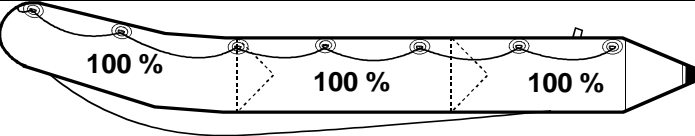
	<p>2</p>	
---	----------	--

**Das Aufpumpen ist beendet:** Die Aufpumpventilverschlussteile zuschrauben.

<p><b>HINWEIS:</b></p>	<p><b>Es ist normal, ein leichtes Ausströmen der Luft vor dem Zuschrauben des Ventilverschlussteiles festzustellen. Die Ventilverschlussteile gewährleisten die endgültige Abdichtung.</b></p>
------------------------	--

## II -4-2- Druck

**Der Betriebsdruck des Auftriebskörpers ist 240 mb/ 3,4 PSI (Mitte des grünen Bereichs des Druckanzeigers).**

Ihr Boot ist mit einem Druckanzeiger **ACCESS** ausgestattet; dies ermöglicht Ihnen ein rasches und sicheres Ablesen des Drucks während des Aufpumpens (siehe Erklärungen für die Verwendung im Abschnitt "Aufpumpsystem").

<p>Die Lufttemperatur oder die Wassertemperatur beeinflussen proportional</p>	<p>Umgebungstemperatur +1°C</p>	<p>Innendruck des Auftriebskörpers +4 mbar / 0,06 PSI</p>
---	-------------------------------------	---

den Innendruck des Schlauchköpers:	-1°C	-4 mbar / 0,06 PSI
------------------------------------	------	--------------------

## AUFTRIEBKÖRPER - Druck

**Es ist auch wichtig zu wissen, wie man den Situationen vorgeht:**  
**Überprüfen Sie den Druck in den aufpumpbaren Kammern und stellen Sie ihn (entweder durch nochmaliges Aufpumpen oder durch Auslassen von Luft) entsprechend den Temperaturschwankungen ein (vor allem bei großen Temperaturunterschieden zwischen Morgen und Abend in sehr heißen Zonen); stellen Sie sicher, dass der Druck nicht vom empfohlenen Druckbereich (von 220 bis 270 mb /grüner Bereich) abweicht.**

### UNTERDRUCKGEFAHR:

**BEISPIEL:** Ihr Boot ist auf dem Strand der prallen Sonne ausgesetzt (Temperatur 50°C), es enthält den empfohlenen Druck (240 mb/3,4 PSI). Wenn Sie das Boot zu Wasser bringen (Temperatur 20°C), werden die Temperatur und der Innendruck in den aufpumpbaren Kammern gleichzeitig sinken (bis 120 mb) und **SIE MÜSSEN NUN DAS BOOT NOCHMALS AUFPUMPEN**, bis die wegen des Temperaturunterschieds zwischen Umgebungsluft und Wasser verloren gegangenen Millibar wieder aufgebaut werden. Es ist auch normal, eine Verringerung des Drucks am Ende des Tages festzustellen, wenn die Außentemperatur sinkt.

### ÜBERDRUCKGEFAHR:

**BEISPIEL:** Ihr Boot ist mit dem empfohlenen Druck (240 mb/3,4 PSI) am Morgen oder am Abend aufgepumpt (niedrige Außentemperatur 10°C). Später, während des Tages, ist Ihr Boot auf dem Strand oder auf dem Deck einer Yacht der prallen Sonne ausgesetzt (Temperatur 50°C). Die Temperatur im Inneren der aufpumpbaren Kammern kann sich daher erhöhen und bis zu 70°C (vor allem dunkelfarbige Auftriebskörper) erreichen, was eine Verdopplung des Ausgangsdruckes zur Folge (480 mb) hat. **SIE MÜSSEN DAHER LUFT ABLASSEN**, um den empfohlenen Druck wieder zu erreichen.

 <b>ACHTUNG</b>	<b>WENN IHR BOOT ZU STARK AUFGEPUMPT IST, IST DER DRUCK AUF DIE AUFPUMPBARE STRUKTUR ZU HOCH; DIES KANN ZUM REISSEN DER STRUKTUR FÜHREN.</b>
---	--

### IM FALL EINES ÜBERDRUCKS



**„EASY-PUSH“ VENTIL:**  
Lassen Sie Luft raus, in dem  
Sie auf das Drücker des  
Ventils drücken.

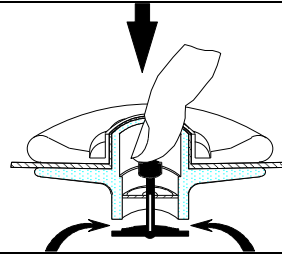

# ANTRIEBSSYSTEM

Halten Sie sich bei der Montage des(der) Motors(Motoren) genau an die Empfehlungen von ZODIAC und Motorhersteller.

Für eine optimale Verwendung Ihres Bootes wenden Sie sich an Ihren Vertragshändler.

# INSTALLATION UND KREISLAUF - Treibstoff

## IV-1-TREIBSTOFF

### IV -1-1-Beschreibung der wichtigsten funktionellen Teile:

Das Boot ist mit einem unter dem Deck gelegenen Tank von 400 l Fassungsvermögen ausgerüstet. Er wird am Bootsbug über einen unter der vorderen Abdeckung gelegenen Einfüllstutzen befüllt.

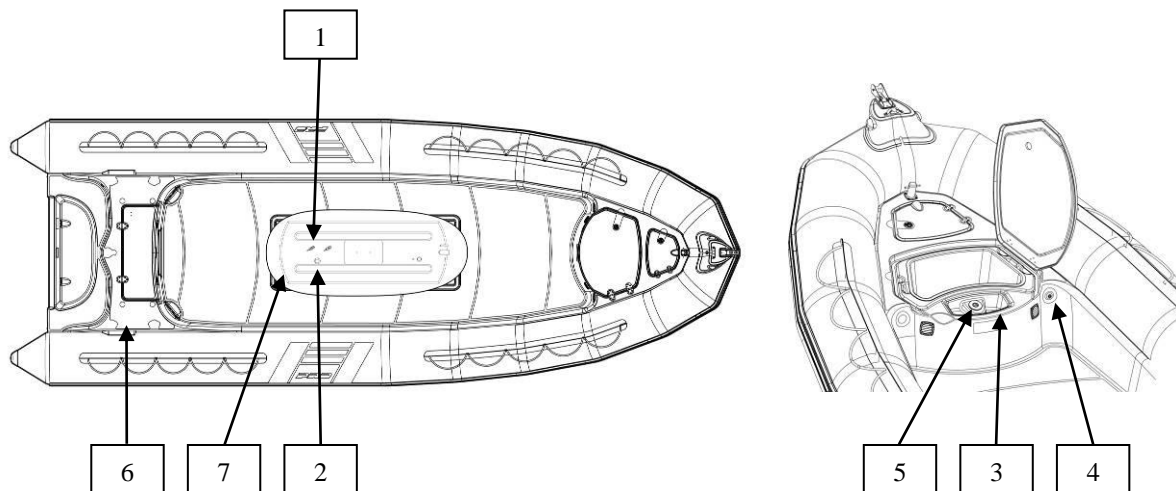

KENNZ.	BEZEICHNUNG
1	Benzinabsperrrventil
2	Übertragung Kraftstoffanzeige
3	Ablassöffnung des Überlaufabteils
4	Entlüftungsstutzen
5	Einfüllöffnung
6	Abscheider Wasser/Benzin (für Einmot-Montage mitgeliefert)
7	Benzintank

 <b>WARNUNG</b>	<input checked="" type="checkbox"/> <b>BEI EINMOT-BETRIEB SCHLIESSEN DES BENZINHAHNS DES ZWEITEN MOTORS NICHT VERGESSEN.</b>
--------------------	--

### IV -1-2-Tank

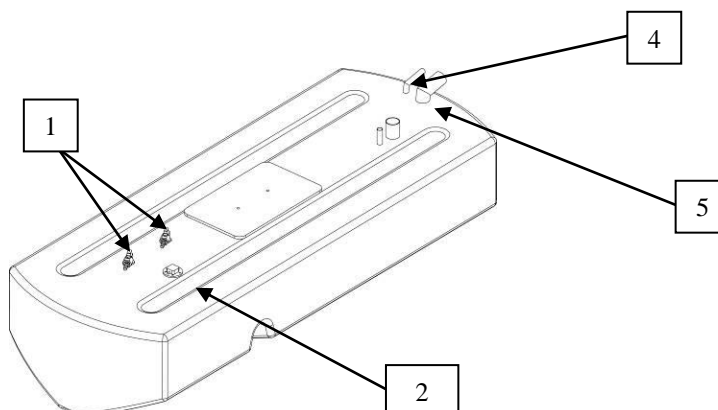

# INSTALLATION UND KREISLAUF - Treibstoff

## IV-1-3-1 Abscheider Wasser / Benzin

<b>HINWEIS:</b>	<b>Um den Motor zu schützen, ist ein Abscheider Wasser/Benzin im Benzinkreislauf des Motors eingebaut.</b>
-----------------	--

Der Abscheider Wasser / Benzin befindet sich im Heckkasten auf der Steuerbordwand. (bei einer Zweimot-Montage bitte Ihren Händler wegen eines zweiten Filters ansprechen)



DEUTSCH

KENNZ.	BEZEICHNUNG
1	Filterkopf, auf dem Boot befestigt
2	Austauschbares Filterelement

 <b>ACHTUNG</b>	<b>DIE FILTERPATRONE MUSS IMMER NACH 50 BETRIEBSSTUNDEN AUSGEWECHSELT WERDEN</b>
--------------------	--

# INSTALLATION UND KREISLAUF - Treibstoff

## Austausch der Filterpatrone:

Halten Sie sich an die Empfehlungen von ZODIAC und Filterhersteller Stellen Sie einen

Auffangbehälter unter den Filter während Sie die Filterpatrone wechseln. Vor dem Filterwechsel vergewissern Sie sich, das die Kraftstoffleitung Druckfrei und der Absperrhahn offen ist. Bitte halten Sie sich genau an die Anweisungen im Handbuch des Motorherstellers.

Benzin ist ein hoch und leicht entzündliches Produkt. **SCHALTEN SIE DEN MOTOR AUS**, trennen Sie die Batterie ab, rauchen Sie nicht und halten Sie alle offenen Flammen sorgfältig fern während Sie mit der Installation des Filters fortfahren. Stellen Sie einen Auffangbehälter unter den Filter während Sie die Filterpatrone wechseln. Vor dem Filterwechsel vergewissern Sie sich, das die Kraftstoffleitung Druckfrei und der Absperrhahn offen ist.

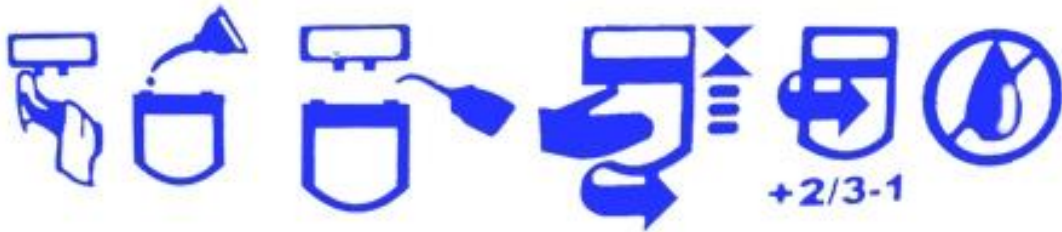

## IV-1-4- Bedienung des Absperrhahns des Benzinkreislaufs:

<b>HINWEIS:</b>	<ul style="list-style-type: none"> <li>- Wenn Sie Ihr Boot nicht mehr verwenden, schließen Sie den Absperrhahn des Benzinkreislaufs.</li> <li>- Wenn Sie Ihr Boot in Betrieb nehmen, öffnen Sie den Absperrhahn des Benzinkreislaufs.</li> </ul>
-----------------	--

Absperrhahn  
Benzinkreislauf  
Offen

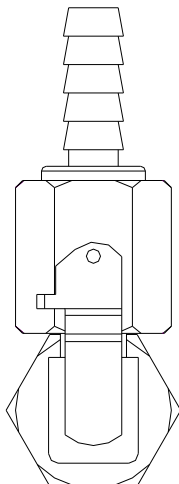

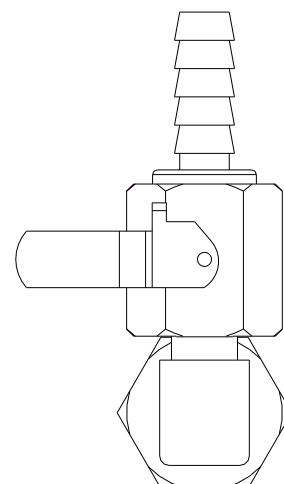
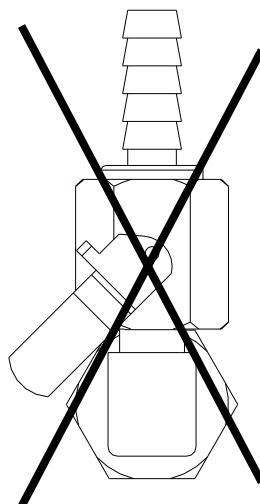

Absperrhahn  
Benzinkreislauf  
Zu



# INSTALLATION UND KREISLAUF - Treibstoff

## IV-1-5-Empfehlungen:

 WARNUNG	<p>IM FALLE EINES BENZINLECKS ODER BRANDS KANN MIT DEM ABSPERRHAHN DES BENZINKREISLAUFS, DER SICH AUF DEM TANK BEFINDET, DER TANK VOM BENZINKREISLAUF GETRENNT WERDEN. DER ABSPERRHAHN MUSS GESCHLOSSEN BLEIBEN.</p>
 WARNUNG	<ul style="list-style-type: none"><li><input checked="" type="checkbox"/> EIN VOLLER TANK VERHINDERT DIE KONDENSATION BEI JEDER AUSFAHRT.</li><li><input checked="" type="checkbox"/> DEN TANK ALLE 5 JAHRE REINIGEN LASSEN.</li><li><input checked="" type="checkbox"/> ÜBERPRÜFEN SIE, OB ALLE SCHLAUCHSCHELLEN AUF DEN GUMMISCHLÄUCHEN EINWANDFREI FESTGEZOGEN SIND.</li><li><input checked="" type="checkbox"/> WENN SIE DEN FILTER ENTLEEREN, DAS WASSER NICHT IN DAS BOOT GIESSEN. BENUTZEN SIE EINEN AUFFANGBEHÄLTER UNTER DEM FILTER.</li><li><input checked="" type="checkbox"/> BEVOR DIE FILTERPATRONE AUSGEBAUT WIRD, DIE ZÜNDUNG AUSSCHALTEN.</li><li><input checked="" type="checkbox"/> AUFMERKSAM DIE ANWEISUNGEN IN DER BETRIEBSANLEITUNG DES FILTERS LESEN.</li></ul>
 WARNUNG	<ul style="list-style-type: none"><li><input checked="" type="checkbox"/> BENZIN IST SEHR LEICHT ENTFLAMMBAR. WENN SIE EINEN EINGRIFF IM BENZINLEITUNGS- UND VERGASERSYSTEM VORNEHMEN, VERGEWISSERN SIE SICH, DASS DIE MOTOREN ABGESTELLT SIND, NICHT GERAUCHT WIRD UND SICH WEDER OFFENE FLAMME NOCH BRENNBARER KÖRPER IN DER NÄHE BEFINDEN.</li></ul> <p>ES DARF NICHT GERAUCHT WERDEN. ENTFERNEN SIE FLAMMEN UND GLÜHENDE KÖRPER AUS DEM ARBEITSBEREICH.</p>
 WARNUNG	<ul style="list-style-type: none"><li><input checked="" type="checkbox"/> NIEMALS IM TANKBEREICH (AN DECK GEKENNZEICHNET DURCH DIE ZUGANGSKLAPPE) MIT EINEM BOHRER ARBEITEN, DER MEHR ALS 30 MM ÜBER DAS BOHRFUTTER HINAUSSTEHT UND KEINE SCHRAUBEN VERWENDEN, DIE LÄNGER ALS 20 MM SIND.</li></ul>

# INSTALLATION UND SCHALTPLAN - Elektrik

## IV -2-ELEKTRIK

IV -2-1-Grundschemata: (ein Schaltplan im A3-Format wird zusammen mit dem Konsole-Verbindungskasten geliefert).

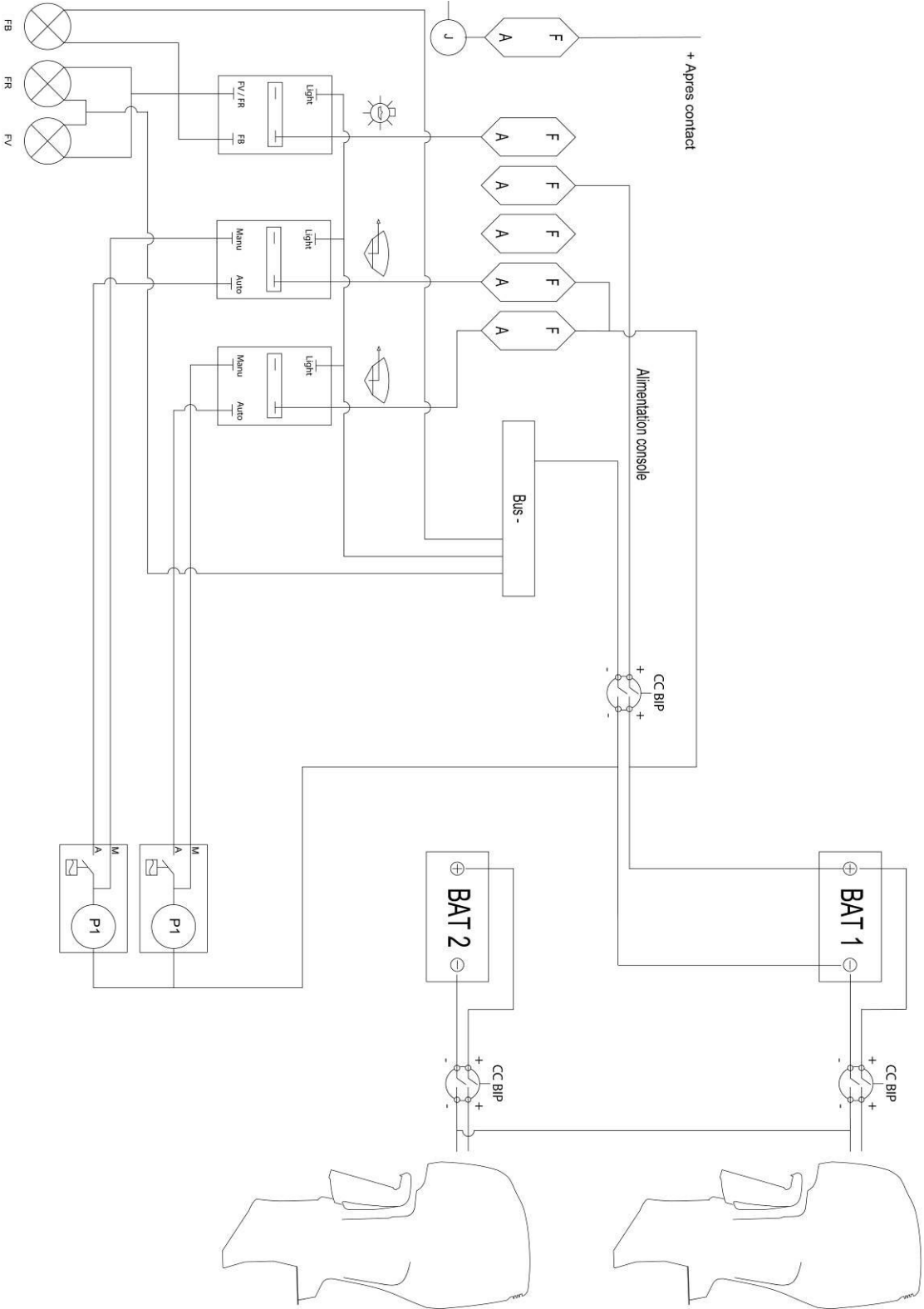





# INSTALLATION UND SCHALTPLAN - Elektrik

## IV-2-3 Lage der Bauteile.

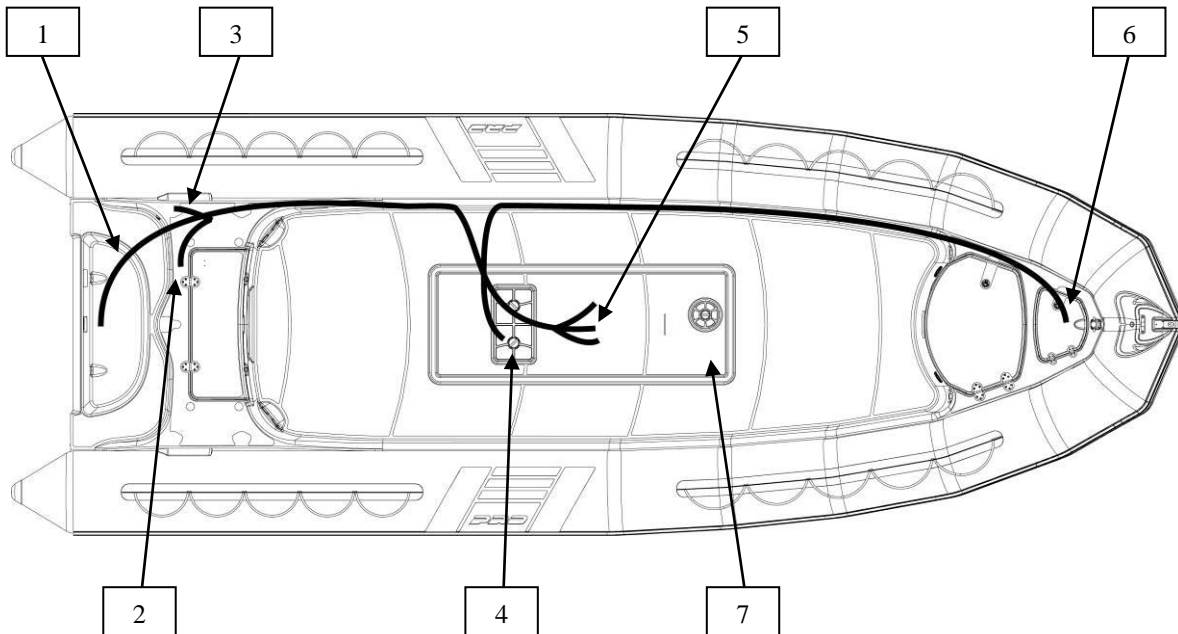

### Entsprechung:

KENNNUMMER	BEZEICHNUNG
1	Stromversorgung Lenzpumpe
2	Kopplerträger und Batteriesicherung
3	Verfügbare Stromversorgung für weiße Leuchte
4	Kraftstoffanzeiger
5	Verfügbares Kabel unter der Klappe für Verkabelung in der Konsole
6	Stromversorgung Seilrollenleuchte
7	Lage der Kabelführung

## IV-2-4-Verkabelung von Verteilerkasten und Schaltern in der Konsole.

Ihr Boot ist ab Werk mit einem elektrischen Leitungsbündel ausgerüstet; es müssen noch bestimmte Elemente in der Konsole angeschlossen werden, nämlich: (der Rest des in der Konsole anzuschließenden Bündels befindet sich unter dem Deck bei Bezugspunkt 5)

- 1 Kasten: Verteiler (Bus-Leiste + Sicherungshalter)



# INSTALLATION UND SCHALTPLAN - Elektrik

- Schalter für Navigationslichter + Lenzpumpen (ebenfalls mitgeliefert).

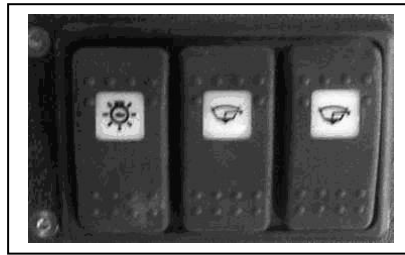

- Kraftstoffanzeiger-Aufnahme.

## IV-2-5 Verkabelungsvorbereitung.

### IV-2-5-1: Montage der Kabelführung. (Geliefert). Bezugspunkt 7

 <b>WARNUNG</b>	<b>BEI BOHRARBEITEN AUF DEN TANK ACHTEN, DER GENAU DARUNTER LIEGT.</b>
--------------------	--

1-Im Winkel bohren.  
Bezugspunkt 7

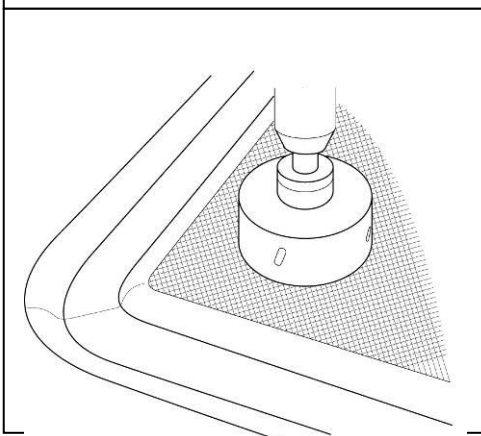

2- Verfügbare Kabel des Bündels sammeln. Bezugspunkt 5

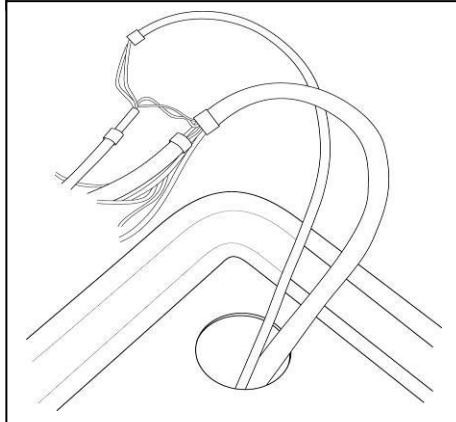

3- Bundring auflegen, um auf Deck vor- und dann durchzubohren.

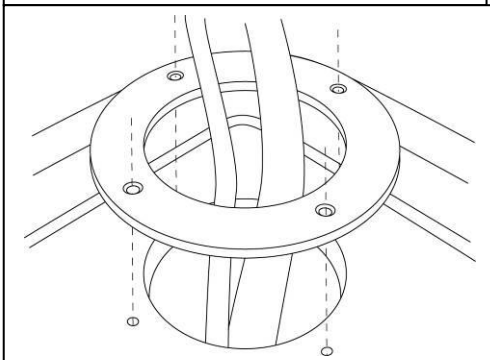

4 -Kabeltülle durchführen, Bundring überstreifen und dann alles auf Deck befestigen. (Schrauben und Kabeltülle gut abdichten)

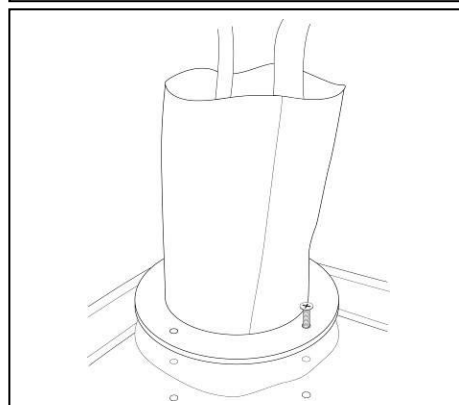

D  
E  
U  
T  
S  
C  
H

# INSTALLATION UND SCHALTPLAN - Elektrik

## IV-2-5-2: Verteilerkastenverkabelung:

Nach Platzierung der Konsole auf Deck und Kabeldurchführung durch das Bodenbrett der Konsole (wenn T4-Konsole) nehmen Sie bitte die Kastenverkabelung vor.

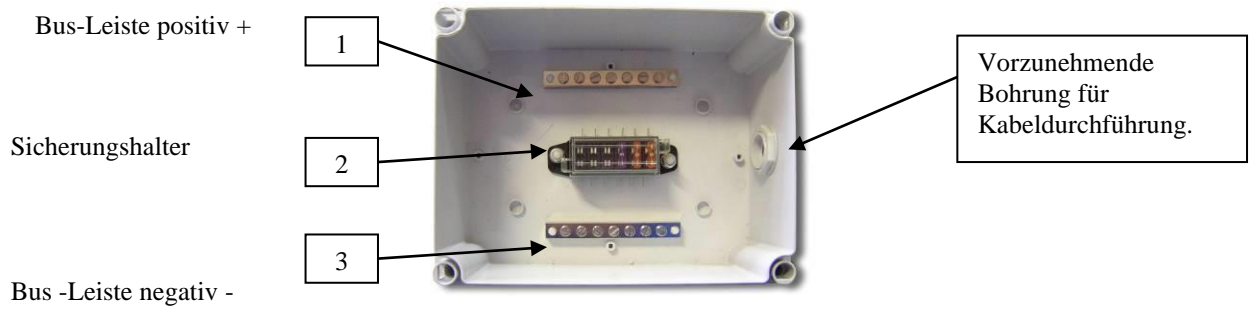

## IV-2-5-3: Verkabelung

- Etappe 1: Folgende Kabel am Sicherungshalter-Bus anschließen (Bezugspunkt 2):

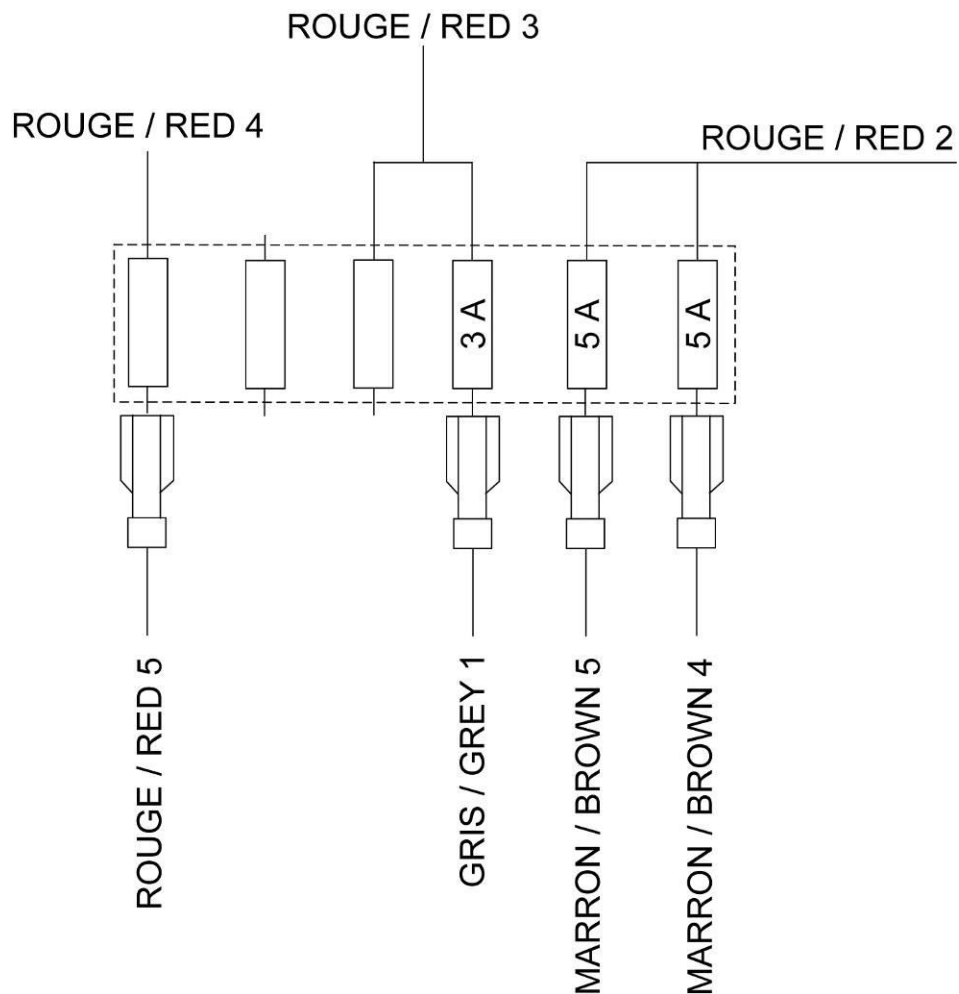

## INSTALLATION UND SCHALTPLAN - Elektrik

- Etappe 2: Folgende Kabel an negativer Bus-Leiste anschließen (Bezugspunkt 3):

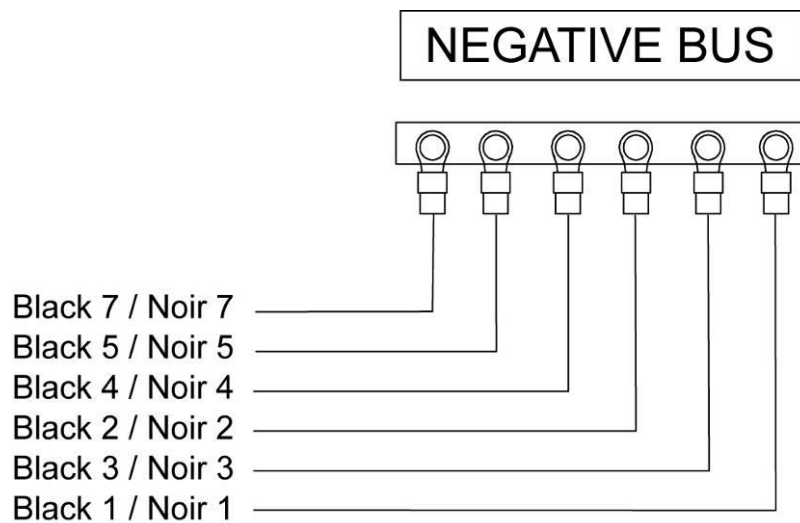

- Etappe 3: Folgende Kabel an positiver Bus-Leiste anschließen (Bezugspunkt 1):

- Etappe 4 : Kasten an der Konsole befestigen.

Vor Kastenbefestigung an Konsoleseite eine Sperrholzplatte aufkleben, um ausreichende Dicke für das Festschrauben zu schaffen.

Anbringen mit Klebstoff

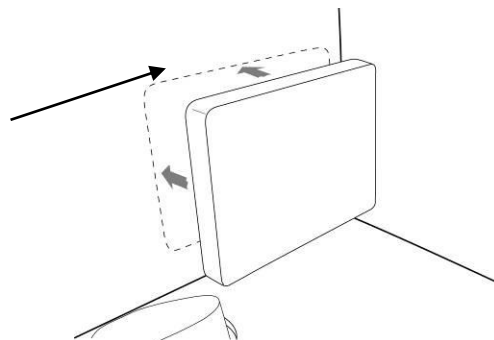

# INSTALLATION UND SCHALTPLAN - Elektrik

Kasten auf der Platte mit Holzschrauben (nicht mitgeliefert) befestigen

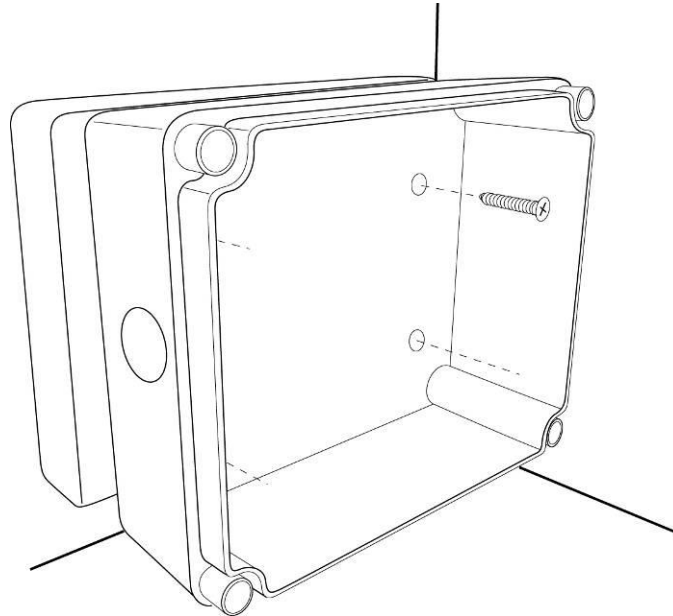

## IV-2-5-4: Schalterverkabelung (Lenzpumpen + Navigationslichter)

- Etappe 1: Schalter auf die Konsole setzen (unter Berücksichtigung der Leitungsbündellänge).

Wenn Sie Ihr Boot mit einer T4-Konsole ausrüsten, raten wir Ihnen, das Schalterpanel wie nachstehend beschrieben anzubringen.

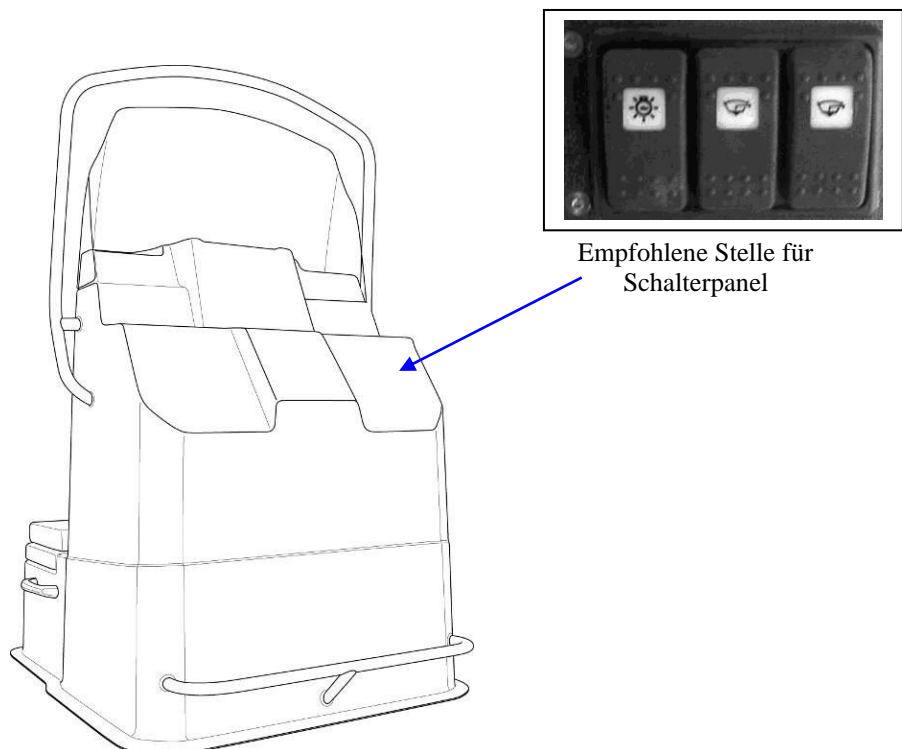

Empfohlene Stelle für Schalterpanel

# INSTALLATION UND SCHALTPLAN - Elektrik

- Etappe 2 : Verkabelung.

Anzuschließende  
Kabelgruppe

Verkabelungsansicht hinter den Schaltern.

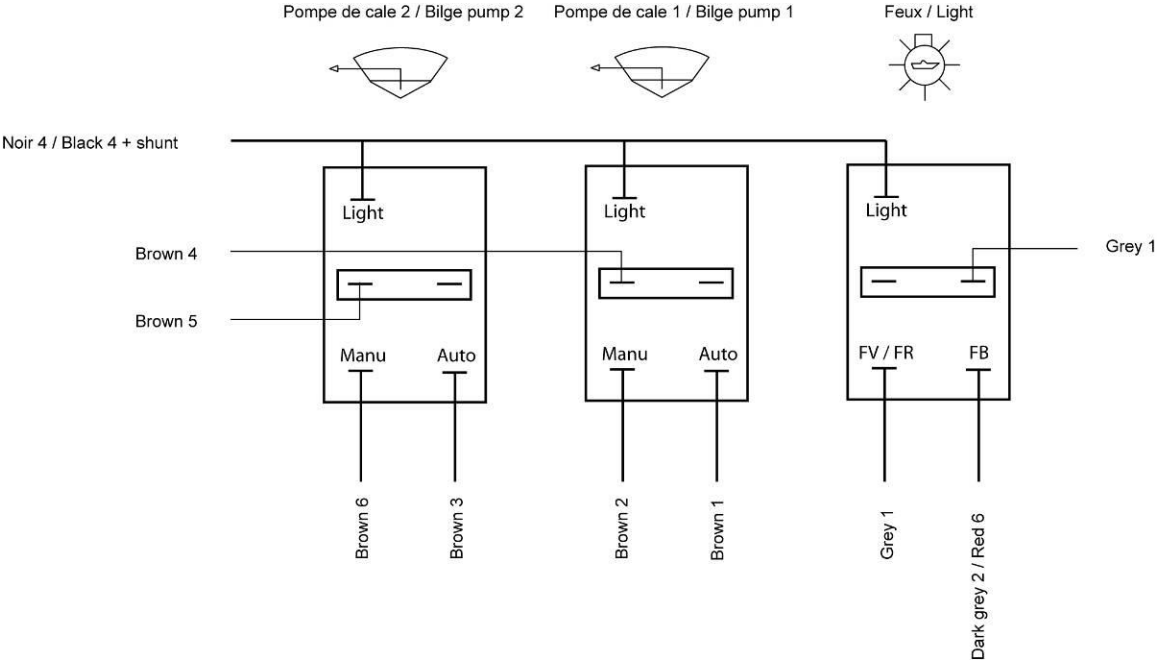

D  
E  
U  
T  
S  
C  
H

# INSTALLATION UND SCHALTPLAN - Elektrik

## IV-2-5-5: Verkabelung der Kraftstoffanzeigeaufnahme. (Hinteransicht).

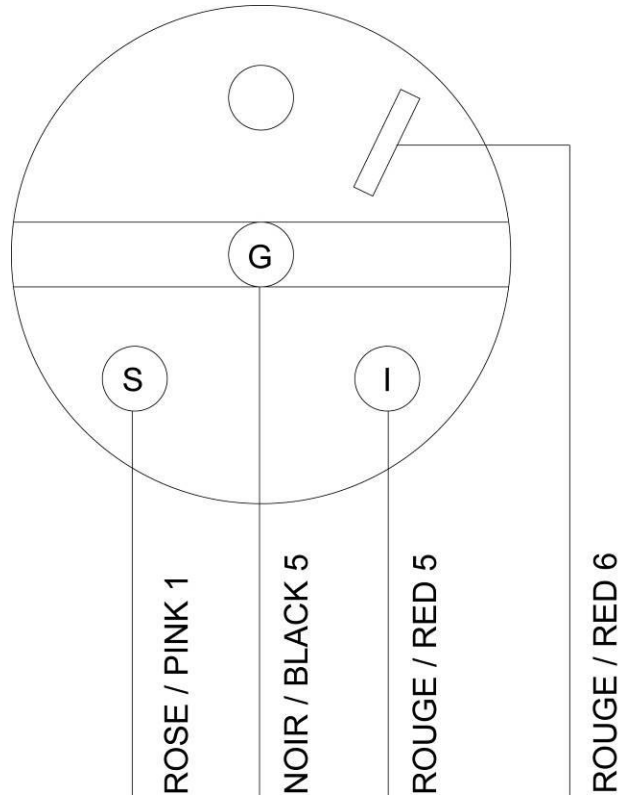

## IV-2-5-6 :- Arbeitsweise von Schutzschalter & Batteriekoppler.

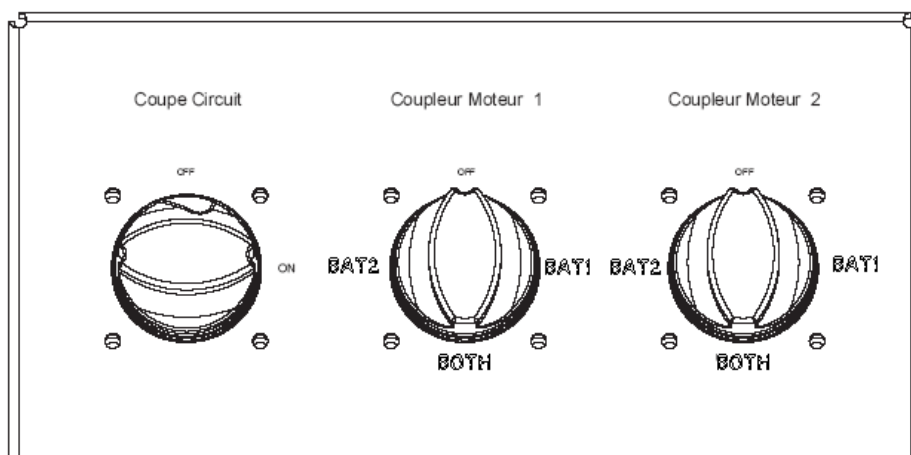

Ihr Boot ist serienmäßig mit einem Schutzschalter und zwei Batteriekopplern ausgerüstet (für Zweimot-Montage).

Bei Einmot-Montage wird nur ein Schalter benutzt.

# EINBAU UND KREISLÄUFE

Der Schutzschalter ermöglicht eine Trennung der Stromversorgung des Verteilerkastens auf der Konsole.

<b>HINWEIS:</b>	Denken Sie nach jeder Bootsbenutzung daran, den Schutzschalter auf AUS zu stellen.
-----------------	--

Die Batteriekoppler ermöglichen, die Motoren entweder durch eine Batterie pro Motor, durch Koppelung der Batterien (Parallelschaltung) oder durch eine einzige Batterie anzulassen.

IV-2-5-7: Tabelle der möglichen unterschiedlichen Konfigurationen.

STELLUNG DER KOPPLER		FOLGE
KOPPLER 1 IN STELLUNG "AUS"	KOPPLER 2 IN STELLUNG "AUS"	<i>MOTOREN UND BATTERIEN SIND GETRENNT</i>
KOPPLER 1 IN STELLUNG "BAT 1"	KOPPLER 2 IN STELLUNG "BAT 2"	<i>JEDER MOTOR STARTET MIT SEINER JEWEILIGEN BATTERIE. KOPPLER IMMER IN DIESE KONFIGURATION VERSETZEN</i>
KOPPLER 1 IN STELLUNG "BAT 1"	KOPPLER 2 IN STELLUNG "BAT 1"	<i>BEIDE MOTOREN STARTEN MIT BATTERIE 1 (wenn Batterie 2 defekt ist)</i>
KOPPLER 1 IN STELLUNG "BAT 2"	KOPPLER 2 IN STELLUNG "BAT 2"	<i>BEIDE MOTOREN STARTEN MIT BATTERIE 2 (wenn Batterie 1 defekt ist)</i>
KOPPLER 1 IN STELLUNG "BEIDE"	KOPPLER 2 IN STELLUNG "BEIDE"	<i>BEIDE MOTOREN WERDEN DURCH KOPPLUNG BEIDER BATTERIEN GESTARTET</i>



# INSTALLATION UND KREISLAUF – Anschluss der Optionen

## IV-2-6 –ANSCHLUSS DER OPTIONEN

### IV -2-6-1-Vorsichtsmaßnahmen:

Das Boot ist serienmäßig mit einer Lenzpumpe und Navigationslichtern ausgestattet. Im Sicherungskasten (unter der Konsole) stehen allerdings unter bestimmten Vorraussetzung noch 2 Plätze für den Anschluss von zusätzlichem Zubehör zur Verfügung:

- ① Das Zubehör, das angeschlossen werden soll, muss an der Konsole angeschlossen werden.
- ② Das Zubehör kann in zwei Kategorien eingeteilt werden:
  - A** → Zubehör, das bei normaler Nutzung des Bootes ununterbrochen oder vermutlich ununterbrochen im Einsatz ist,
  - B** → Zubehör, das zeitweise eingesetzt wird.

A		und	B	
Raumlüfter			Zigarettenanzünder	
Radio			Diverse Beleuchtungen	
Lotgerät			Warnhorn	
GPS			Diverse elektronische Geräte	
Scheinwerfer			Duschpumpe	
Alarmanlage			Maximale Leistung	60W max.
Kühlschrank				
VHF-Sender				
$\Sigma$	180W maxi			

 <b>WARNUNG</b>	<p><b>Sie müssen sich unbedingt vergewissern, dass die Gesamtleistung aller in Spalte A enthaltener Zusatzgeräte, die Sie <u>hinzufügen</u>, 180W (15A) nicht übersteigt, <u>UND</u> dass die maximale Leistung eines Zusatzgeräts der Spalte B 60W (5A) nicht übersteigt. Die Querschnitte der verschiedenen Kabel des Bündels wurden nach diesen Richtwerten berechnet; die Nichtbeachtung dieser Vorschrift kann zu elektrischen Störungen führen oder Kurzschlüsse verursachen.</b></p>
---	---

Durch Einfügung eines zugelassenen Sicherungshalters können Sie die Optionen direkt auf der positiven und negativen Bus-Leiste der Konsole anschließen (innerhalb der maximalen Leistung).

# INSTALLATION UND KREISLAUF – Anschluss der Optionen

## Beispiel 1

Sie möchten folgende zusätzliche Geräte anschließen:

Einen VHF-Sender mit 72W,

Ein GPS mit 36W,

Ein Radio mit 60W,

Einen Zigarettenanzünder mit 72W,

Eine Uhr mit 20W.

A	
Raumlüfter	
Radio	60W
Lotgerät	
GPS	36W
Scheinwerfer	
Alarmanlage	
Kühlschrank	
VHF-Sender	72W
Σ	168W (<180W ) ☺

und

B	
Diverse Beleuchtungen	
Diverse elektronische Geräte	20W (Uhr)
Duschpumpe	
Maximale Leistung	60W (< oder = 60W) ☺

ERGEBNIS	
----------	---

## Beispiel 2

Sie möchten folgende zusätzliche Geräte anschließen:

Einen VHF-Sender mit 60W,

Ein GPS mit 36W,

Ein Radio mit 48W,

Einen Scheinwerfer mit 120W.

A	
Raumlüfter	
Radio	48W
Lotgerät	
GPS	36W
Scheinwerfer	120W
Alarmanlage	
Kühlschrank	
VHF-Sender	60W
Σ	264W (> 180W) ☹

und

B	
Diverse Beleuchtungen	
Diverse elektronische Geräte	
Duschpumpe	
Maximale Leistung	0 (< 60W) ☹

ERGEBNIS	
----------	---

# INSTALLATION UND KREISLAUF – Anschluss der Optionen

## Beispiel 3

Sie möchten folgende zusätzliche Geräte anschließen:

Ein GPS mit 60W,

Ein Radio mit 60W,

Ein Warnhorn mit 120W.

A	
Raumlüfter	
Radio	60W
Lotgerät	
GPS	60W
Scheinwerfer	
Alarmanlage	
Kühlschrank	
VHF-Sender	
Σ	120W (< 180W) ↻

und

B	
Diverse Beleuchtungen	
Diverse elektronische Geräte	
Duschpumpe	
Maximale Leistung	120W (> 60W) ⚡

ERGEBNIS	
----------	--

<b>HINWEIS:</b>	<b>Einige Hersteller geben an Stelle der Leistungsaufnahme die Stromstärke an. Bei Gleichstrom (vorliegender Fall) genügt eine Multiplikation mit 12, um die Leistung zu erhalten. Bei Division der Leistung mit 12 erhält man die beanspruchte Stromstärke des Geräts.</b>
-----------------	---

## IV -4-2-6-2-Verkabelung:

- ① Wählen Sie einen freien Sicherungsplatz,
- ② Schließen Sie das Versorgungskabel ihres Zusatzgeräts mit Hilfe einer 6 mm-Rundsteckhülse an die entsprechende Klemme an diesem Platz an,
- ③ Wenn Sie mehr Kabel für den Anschluss benötigen, verwenden Sie Kabel mit einem Mindestquerschnitt von 1,5 mm<sup>2</sup> unter Beachtung der Vorschriften für Seekabel (UL1426, SAE J378, SAE J1127, SAE J1128 oder ein den allgemeinen ABYC und/oder CE-Vorschriften entsprechendes Kabel),
- ④ Schließen Sie das Erdungskabel ihres Zusatzgeräts mit Hilfe einer „Ösenklemme“ von 5 mm Durchmesser an die Masseklemmleiste an (hier gelten die gleichen Hinweise wie oben für das Kabel),
- ⑤ Setzen Sie eine Sicherung vom Typ ATO ein, deren Stromstärke maximal 15A beträgt und die über der Einsatzstromstärke Ihres Geräts liegt.

# INSTALLATION UND KREISLAUF – Anschluss der Optionen

## IV -2-7-FUNKTIONSWEISE DER LENZPUMPE

Die Funktionsweise der Lenzpumpe ist unabhängig von der Stellung des Batterie-Trennschalters; der Steuerungsschalter  steht immer unter Spannung.

- ① Automatischer Betrieb (feste Stellung). In dieser Stellung arbeitet die Lenzpumpe automatisch. Die Anzeige ist eingeschaltet.
- ② Stopp. In dieser Stellung (fest) ist die Lenzpumpe ausgeschaltet. Die Anzeige ist ausgeschaltet.
- ③ Erzwungener Betrieb. Für den erzwungenen Betrieb muss der Schalter dauerhaft gedrückt werden. Sobald Sie den Schalter loslassen, kehrt er in die Stellung Stopp (2) zurück.

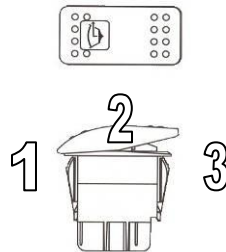



 <b>WARNUNG</b>	<b>BEIM ANKERN MUSS DER LENZPUMPENSCHALTER IN DIE STELLUNG AUTOMATISCHER BETRIEB GEBRACHT WERDEN.</b>
<b>HINWEIS:</b>	<b>ZODIAC EMPFIEHLT DIE VERWENDUNG EINER ABDECKPLANE, UM DAS EINDRINGEN VON REGENWASSER ZU VERMEIDEN.</b>

# EINBAU UND KREISLAUF - Elektrik

## IV-2-8- Batterie (nicht mitgeliefert)

Halten Sie sich bei den laufenden Wartungsarbeiten genau an die Empfehlungen von ZODIAC und Batteriehersteller.

	<p>Warten und pflegen Sie Ihre Batterie:</p> <ul style="list-style-type: none"> <li><input checked="" type="checkbox"/> Halten sie die Batterie sauber und trocken, um eine vorzeitige Alterung zu vermeiden.</li> <li><input checked="" type="checkbox"/> Ziehen Sie die Batterieanschlussklemmen fest; schmieren Sie sie regelmäßig mit Vaseline.</li> </ul>
---	--

 <b>ACHTUNG</b>	<p><b>DAS WASSER AUS DEM WASSERLEITUNGSSYSTEM ENTHÄLT MINERALIEN, WELCHE DIE BATTERIEN BESCHÄDIGEN. DAHER AUSSCHLIESSLICH DESTILLIERTES WASSER ZUM NACHFÜLLEN VERWENDEN.</b></p>
 <b>WARNUNG</b>	<ul style="list-style-type: none"> <li>• <b>DIE BATTERIEN UND DIE ELEKTROLYTFLÜSSIGKEIT AUSSER REICHWEITE VON KINDERN AUFBEWAHREN</b></li> <li>• <b>BATTERIE STETS AUFRECHT ABSTELLEN.</b></li> <li>• <b>WENN SIE ELEKTROLYTFLÜSSIGKEIT NACHFÜLLEN ODER DIE BATTERIE AUFLADEN, NEHMEN SIE SIE IMMER AUS DEM MOTORRAUM HERAUS</b></li> <li>• <b>DIE ELEKTROLYTFLÜSSIGKEIT DER BATTERIE IST GIFTIG UND HÖCHST GEFÄHRLICH. SIE ENTHÄLT SCHWEFELSAURE. DIESE KANN SCHWERE VERÄTZUNGEN VERURSACHEN. VERMEIDEN SIE JEDEN KONTAKT MIT HAUT, AUGEN UND KLEIDUNGSSTÜCKEN.</b></li> <li>• <b>DIE BATTERIEN KÖNNEN EXPLOSIONSGEFÄHRLICHE GASE FREISETZEN. HALTEN SIE FUNKENQUELLEN, OFFENE FLAMMEN, ZIGARETTEN USW. FERN</b></li> <li>• <b>WENN SIE EINE BATTERIE AUFLADEN ODER BENUTZEN, FÜHREN SIE DIES AN EINEM GUT BELÜFTETEN ORT DURCH. SCHÜTZEN SIE IMMER IHRE AUGEN, WENN SIE IN DER NÄHE EINER BATTERIE ARBEITEN.</b></li> </ul>

<b>HINWEIS:</b>	<ul style="list-style-type: none"> <li><input checked="" type="checkbox"/> Wenn Sie Ihr Boot mehr als einen Monat lang nicht benutzen, bauen Sie die Batterie aus und lagern Sie diese an einem kühlen, dunklen und trockenen Ort. Laden Sie die Batterie vollständig auf, bevor sie wieder verwendet wird.</li> <li><input checked="" type="checkbox"/> Wenn die Batterie über einen längeren Zeitraum gelagert werden muss, überprüfen Sie die Dichte der Elektrolytflüssigkeit mindestens einmal im Monat und laden Sie die Batterie auf, sobald die Dichte zu niedrig ist.</li> </ul> <p><b>Dichte der Elektrolytflüssigkeit: 1,28 bei 20°C</b></p>
-----------------	---

<b>HINWEIS:</b>	<p><b>Wenn Sie Ihr Boot nicht mehr benutzen, stellen Sie den Schutzschalter auf AUS.</b></p>
-----------------	--

# EINBAU UND KREISLAUF - Lenzen

## IV -3-LENZEN:

### IV -3-1-Beschreibung der wichtigsten funktionellen Teile:

Das Boot ist selbstlenzend. Es ist mit 4 großen Schnellablässen am hinteren Decksteil ausgerüstet.

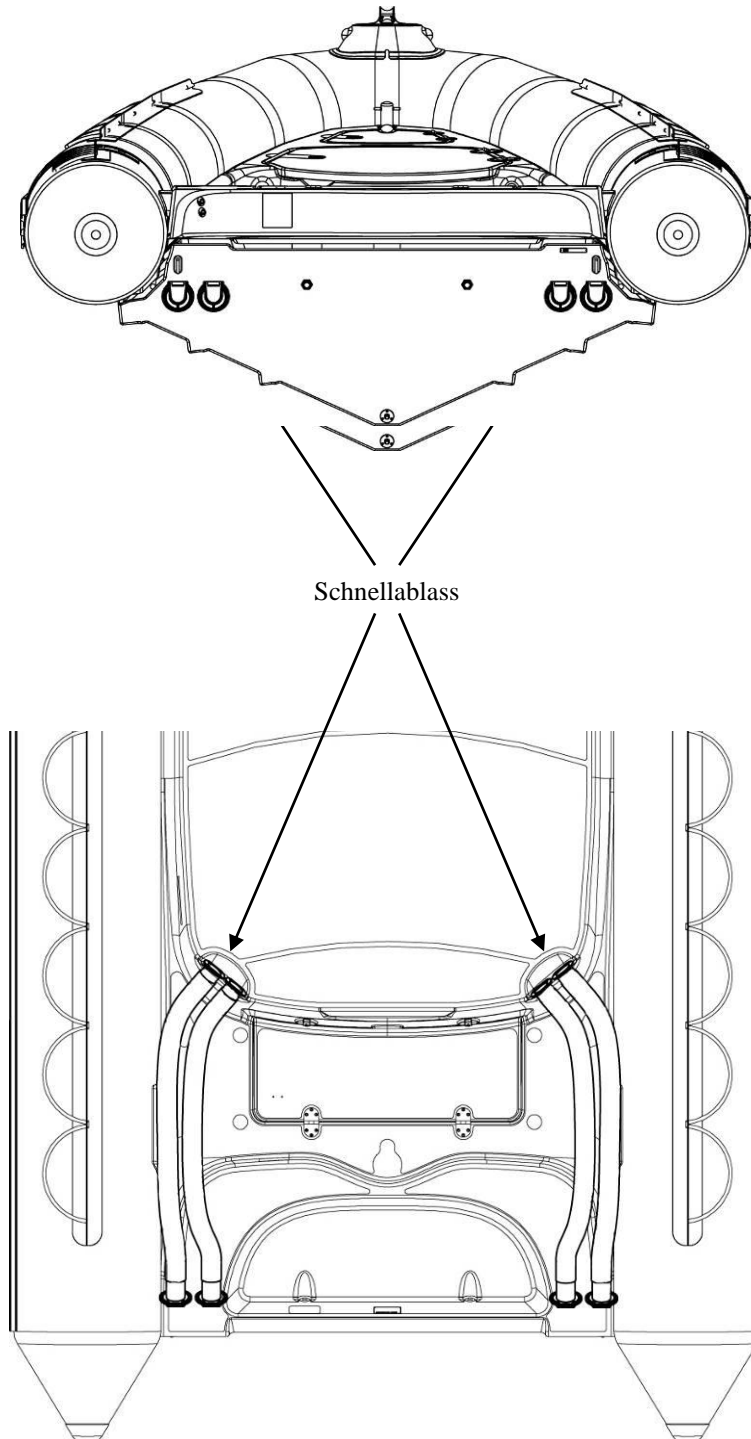

# EINBAU UND KREISLAUF - Lenzen

## IV-3-2-Stopfen der Rumpfentleerungsöffnung

### IV-3-2-1-Boot nicht im Wasser (Anhänger, Stapellaufschlitten...)

	<b>STELLUNG OFFEN, STOPFEN ENTFERNT.</b>
---	--

### IV-3-2-2-Boot im Wasser

	<b>STELLUNG GESCHLOSSEN, STOPFEN ANGEBRACHT. (SICH VERGEWISSEN, DASS RUMPFENTLEERUNGÖFFNUNG RICHTIG VERSCHLOSSEN IST)</b>
---	---

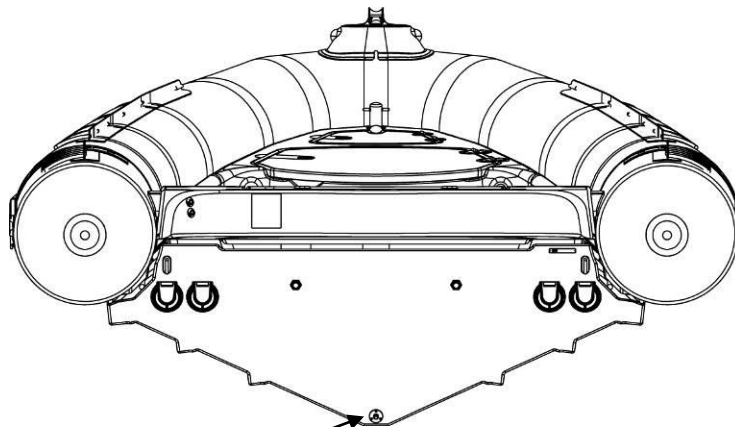

Entleerungsöffnung

## **EINBAU UND KREISLAUF - Steuerung**

### **IV-4-STEUERUNG**

Bei Einmot- und in bestimmten Fällen auch bei Zweimot-Montage kann ein hydraulischer Antrieb (Option) verwendet werden (siehe höchstzulässige Leistung).

Halten Sie sich genau an die Empfehlungen des Steuerungsherstellers (Einbau, Verwendung und Wartung).

Für eine optimale Verwendung Ihres Bootes wenden Sie sich an Ihren Vertragshändler.

## **EINBAU UND KREISLAUF - BRANDSCHUTZ**

### **IV-5- Brandschutz**



**WIR EMPFEHLEN IHNEN, EINEN FEUERLÖSCHER AN BORD ZU HABEN. HALTEN SIE SICH GENAU AN DIE GELTENDEN GESETZLICHEN VORSCHRIFTEN IN IHREM LAND.**



# EINBAU UND KREISLAUF - Ankern/Vertäuen

## IV-6- ANKERN /VERTÄUEN

### IV -6-1-Beschreibung der wichtigsten funktionellen Teile:

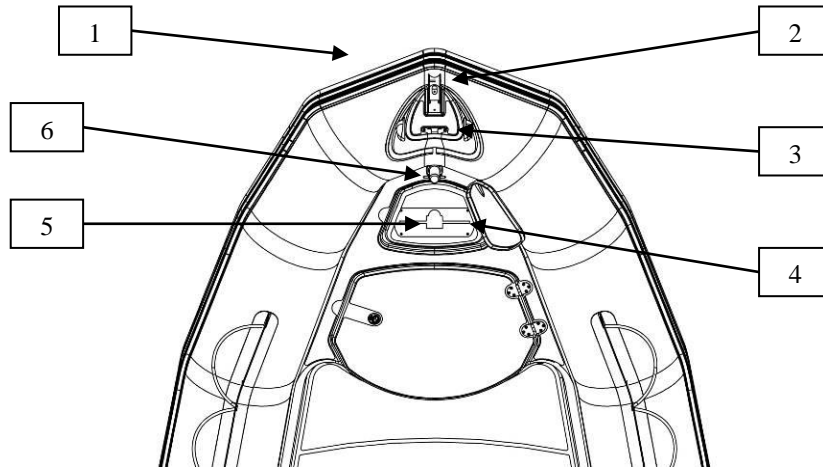

KENNZ.	BEZEICHNUNG
1	Vorstevenring
2	Seilrollenhalterung + Seilrolle
3	Verholklampe
4	Ankerkasten
5	Ankerkastendeckel
6	Vertäuungsklampe

### IV-6-2- Verwendung:

 <b>WARNUNG</b>	<p><b>DIE KLAMPEN ERMÖGLICHEN LEDIGLICH EIN GELEGENTLICHES VERTÄUEN DES BOOTES. EIN LANGFRISTIGES VERTÄUEN MUSS MIT HILFE DES AM BOOTSBUG ANGEBRACHTEN RÜSTEISENS ERFOLGEN.</b></p>
---	---

# BESCHILDERUNG

## V -1-LAGE DER SICHERHEITSAUFKLEBER UND HINWEISSCHILDER

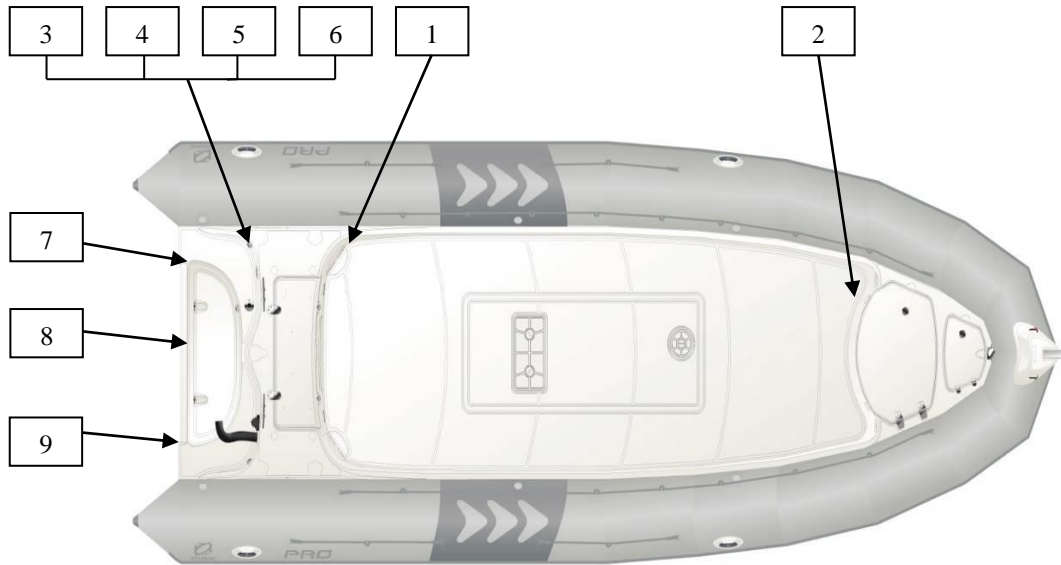

# BESCHILDERUNG

## V -2-BESCHREIBUNG DER SICHERHEITSAUFKLEBER UND HINWEISSCHILDER



<b>⚠ WARNING</b>	<b>⚠ VORSICHT</b>
<ul style="list-style-type: none"> <li>• DO NOT TOUCH BATTERY TERMINALS (SHOCK AND ACID HAZARDS)</li> <li>• DISCONNECT BOTH LEADS BEFORE REMOVING BATTERY</li> <li>• CONNECT RED LEAD TO POSITIVE (+) TERMINAL</li> <li>• CONNECT BLACK LEAD TO NEGATIVE (-) TERMINAL</li> </ul>	<ul style="list-style-type: none"> <li>• DIE KLEMMEN DER BATTERIE NICHT BERÜHREN (ELEKTROSCHOCKGEFAHR UND GEFAHREN IN ZUSAMMENHANG MIT SÄURE)</li> <li>• DIE BEIDEN AUSGANGSLEITER VOR DEM ENTFERNEN DER BATTERIE ABSTECKEN</li> <li>• DAS ROTE KABEL MIT DER POSITIVEN KLEMME (+) VERBINDEN</li> <li>• DAS SCHWARZE (ODER GELBE) KABEL MIT DER NEGATIVEN KLEMME (-) VERBINDEN</li> </ul>

1



<b>⚠ WARNING</b>	<b>⚠ WARNUNG</b>
<p style="text-align: center;"><b>GASOLINE IS HIGHLY INFLAMMABLE AND EXPLOSIVE</b></p> <ul style="list-style-type: none"> <li>• STOP ENGINE BEFORE REFUELING</li> <li>• REFUEL IN WELL VENTILATED AREA</li> <li>• NEVER REFUEL WHILE SMOKING, AROUND SPARKS OR OPEN FLAME</li> <li>• AVOID SPILLING FUEL. WIPE UP ALL FUEL SPILLS IMMEDIATELY</li> <li>• LEAKING FUEL IS A FIRE HAZARD AND EXPLOSION HAZARD</li> <li>• INSPECT FUEL SYSTEM BEFORE EACH USE</li> </ul>	<p style="text-align: center;"><b>BENZIN IST SEHR LEICHT ENTFLAMMBAR UND EXPLOSIV</b></p> <ul style="list-style-type: none"> <li>• DEN MOTOR VOR DEM AUFTANKEN ABSTELLEN</li> <li>• BEIM AUFTANKEN NICHT RAUCHEN, NICHT IN DER NÄHE VON FUNKENSCHLAG ODER OFFENER FLAMME AUFTANKEN</li> <li>• VERMEIDEN SIE ES, DEN KRAFTSTOFF ZU VERSCHÜTTEN. ALLE KRAFTOFFPFÜTZEN SOFORT NACH IHREM AUFTRETEN WEGWISCHEN</li> <li>• KRAFTSTOFFLECKS STELLEN EINE BRAND- UND EXPLOSIONSGEFAHR DAR</li> <li>• PRÜFEN SIE DIE KRAFTSTOFFANLAGE VOR JEDEM GEBRAUCH</li> </ul>

2

<b>⚠ CAUTION</b>	<b>⚠ VORSICHT</b>
<p style="text-align: center;"><b>IMPROPERLY TOWING YOUR BOAT CAN CAUSE SEVERE DAMAGE TO YOUR BOAT.</b></p> <ul style="list-style-type: none"> <li>• NEVER TOW IN OPEN SEAS</li> <li>• NEVER TOW ABOVE 6 KNOTS</li> </ul>	<p style="text-align: center;"><b>DAS FALSCHES SCHLEPPEN IHRES BOOTS KANN SCHWERE SCHÄDEN AM BOOT VERSURSACHEN</b></p> <ul style="list-style-type: none"> <li>• NIE AUF OFFENER SEE SCHLEPPEN</li> <li>• SCHLEP GESCHWINDIGKEIT NICHT ÜBER 6 KNOTEN</li> </ul>

3

<b>⚠ WARNING</b>	<b>⚠ WARNUNG</b>
<p style="text-align: center;"><b>DO NOT LIFT THE BOAT WITH PASSENGERS ON BOARD</b></p>	<p style="text-align: center;"><b>DAS BOOT DARF NICHT AUFGEHOBEN WERDEN, SOLANGE SICH LEUTE AN BORD BEFINDEN</b></p>

4

# BESCHILDERUNG

<p style="text-align: center; font-size: 24px; margin: 0;"><b>⚠ DANGER</b></p> <p style="font-size: 12px; margin: 5px 0;">TO AVOID INJURY OR DEATH, SHUT OFF ENGINE WHEN NEAR SWIMMERS OR PRIOR TO USING SWIN PLATFORM AND BOARDING LADDER</p>	<p style="text-align: center; font-size: 24px; margin: 0;"><b>⚠ GEFAHR</b></p> <p style="font-size: 12px; margin: 5px 0;">UM VERLETZUNGEN ODER TOD ZU VERMEIDEN, MUSS DER MOTOR IN DER NÄHE VON SCHWIMMERN ODER VOR DEM GEBRAUCH EINER SCHWIMMPLATTFORM ODER EINER BOOTSLEITER ABGESCHALTET WERDEN</p>
	<b>5</b>

<p style="font-size: 24px; margin: 0;"><b>⚠ DANGER</b></p>	<p style="font-size: 24px; margin: 0;"><b>⚠ VORSICHT</b></p>
<p style="text-align: center; font-size: 12px; margin: 0;">A FIRE EXTINGUISHER MUST BE CARRIED AT ALL TIMES</p>	<p style="text-align: center; font-size: 12px; margin: 0;">AN BORD MUSS JEDERZEIT EIN FEUERLÖSCHGERÄT VERFÜGBAR SEIN</p>
	<b>6</b>

INSTRUCTIONS

**7**

ZODIAC Z MARINE - 6-10 rue Troyon - 92316 - Sèvres - France

MODELE MODEL [ ] bar [ ] psi    SERIE SERIAL [ ]

+ + + ≤ [ ] kg [ ] lbs

≤ [ ] kg → [ ] (Lbs)  
 ≤ [ ] Kw → [ ] (H.P./CV)

CONFORME A Conforms to ISO 6185 [ ]

[ ]    CATEGORIE CONCEPTION DESIGN CATEGORY [ ]  
 8425 CE    MADE IN [ ]

**8**

FR- XDCXXXXXXXXXX

**9**

	<p style="text-align: center; font-size: 12px; margin: 0;"><b>ÜBERPRÜFEN SIE DAS VORHANDENSEIN UND DIE LESBARKEIT DER AUFKLEBER. WENDEN SIE SICH BEI BEDARF AN IHERN VERTRAGSHÄNDLER.</b></p>
--	---

D  
E  
U  
T  
S  
C  
H

# EINBAUSTELLEN DES OPTIONALEN ZUBEHÖRS

## VI -1-EINBAUSTELLE T4-KONSOLE. (sowohl Navigationskategorie B als auch C)

Ihr Boot kann mit einer optionalen Konsole T4 ausgerüstet werden (sprechen Sie Ihren Zodiac-Händler an).

In der Absicht, die Bootsnutzung zu optimieren und von allen Zugängen unter das Deck zu profitieren (Tank/elektrische Verkabelung und Kabeldurchführung), empfehlen wir Ihnen, die Konsole in der nachstehend bezeichneten Zone zu platzieren.

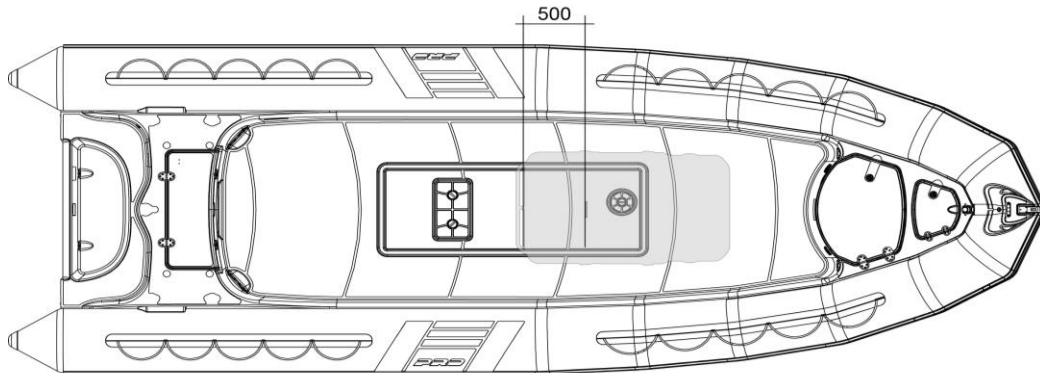

**UM VON DER KABELDURCHFÜHRUNG UNTER DECK ZU PROFITIEREN UND UM DIE BOOTSSTRUKTUR NICHT ZU BESCHÄDIGEN, MUSS DIE KABELTÜLLE (NICHT MITGELIEFERT) UNBEDINGT IN DER VORSTEHEND BEZEIGTEN UND GRAU UNTERLEGTEN ZONE PLATZIERT WERDEN**

### I-5-1-2-KABELDURCHFÜHRUNG:

Die Durchführung der Kabel und Benzinschläuche des Motors ist unter Deck vorgesehen. (durch im Werk vormontierte Durchführungstüllen).

Austritt der Kabel an Deck (mit Hilfe einer Durchführungstülle).

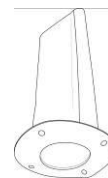

Zone für die Durchführung der Kabel.

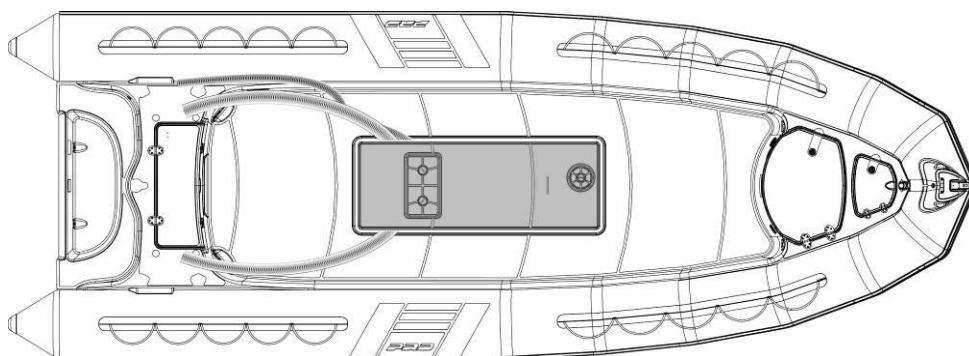

# EINBAUSTELLEN DES OPTIONALEN ZUBEHÖRS

 <b>WARNUNG</b>	<p><b>AUS SICHERHEITSGRÜNDEN MUSS DIE TANKZUGANGSKLAPPE FREI BLEIBEN UND DARF NICHT DURCH EIN ZUBEHÖRTEIL BLOCKIERT WERDEN. SIE KANN ALLERDINGS VOLLSTÄNDIG VON DER KONSOLE ÜBERDECKT SEIN, ABER IHR ZUGANG MUSS ÜBER DEN VOR IHR LIEGENDEN KASTEN MÖGLICH SEIN.</b></p>
---	--

 <b>ACHTUNG</b>	<p><b>NIEMALS IM TANKBEREICH MIT EINEM BOHRER ARBEITEN, DER MEHR ALS 30 MM ÜBER DAS BOHRFUTTER HINAUSSTEHT, UND KEINE SCHRAUBEN VERWENDEN, DIE LÄNGER ALS 20 MM SIND.</b></p>
---	---

## VI-1-3-Einbaustelle Zubehör SITZ T4 / POLSTER T4 (je nach Modellkategorie)

Je nach Navigationskategorie, in der Sie das Boot benutzen wollen, hier 2 Einbaustellen für Sitz oder Polster entsprechend der gewünschten Sitzplatzzahl.

### VI-1-3-1-Kategorie C.

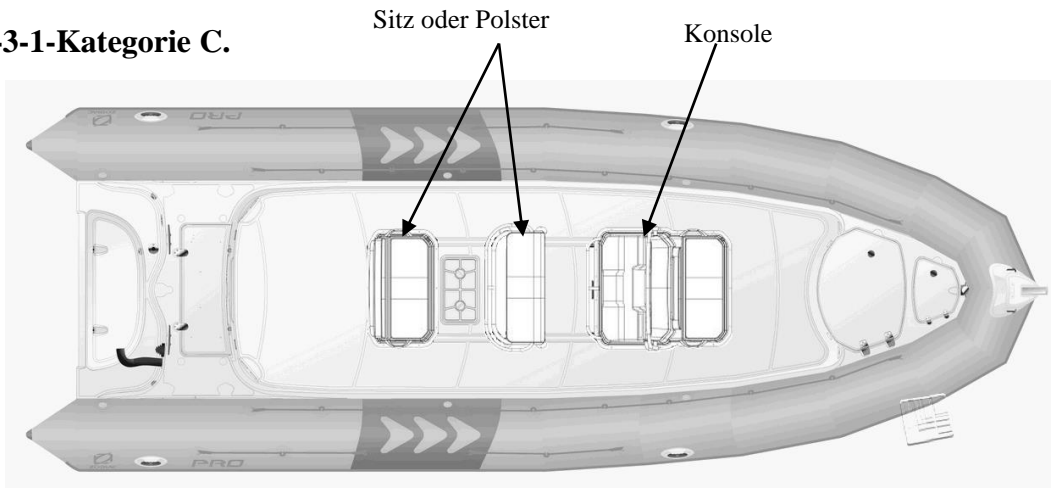

**VI-1-3-1-Kategorie B. Die Personenzahl in Kategorie B ist auf 10 beschränkt. Alle Personen müssen einen Sitzplatz einnehmen.**

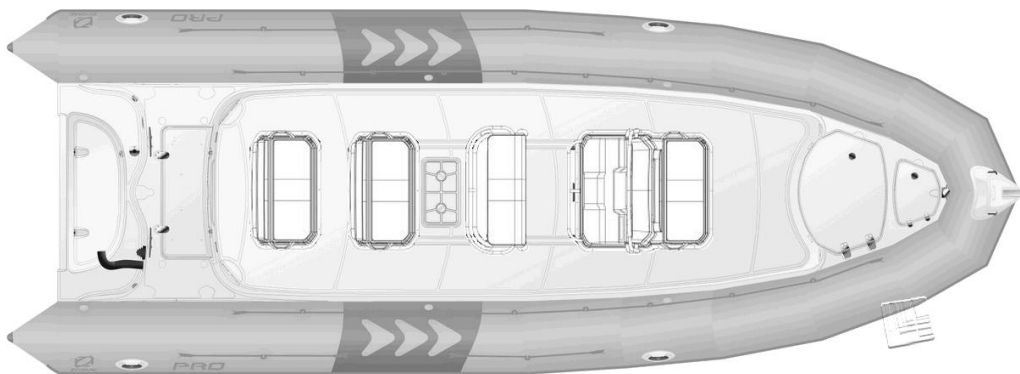

**D  
E  
U  
T  
S  
C  
H**

## EINBAUSTELLEN DES OPTIONALEN ZUBEHÖRS

VI-1-4-Einbaustelle ÜBERROLLBÜGEL. (jeder Option ist eine detaillierte Anleitung beigelegt).

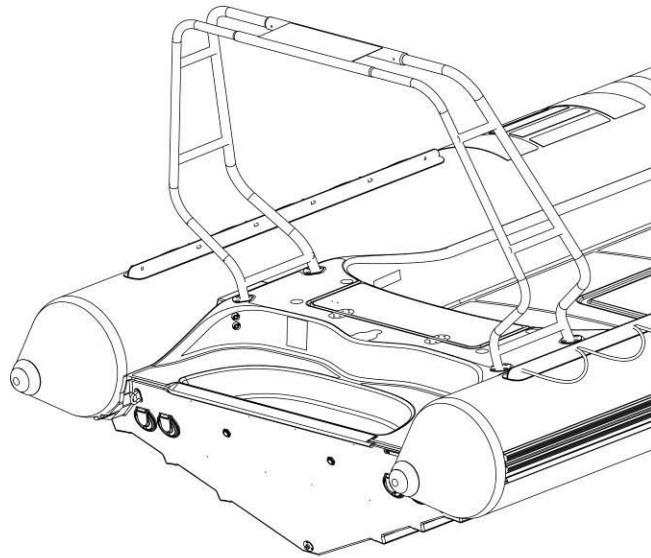

VI-1-5-Einbaustelle Wasserskimast / Rückenlehne.

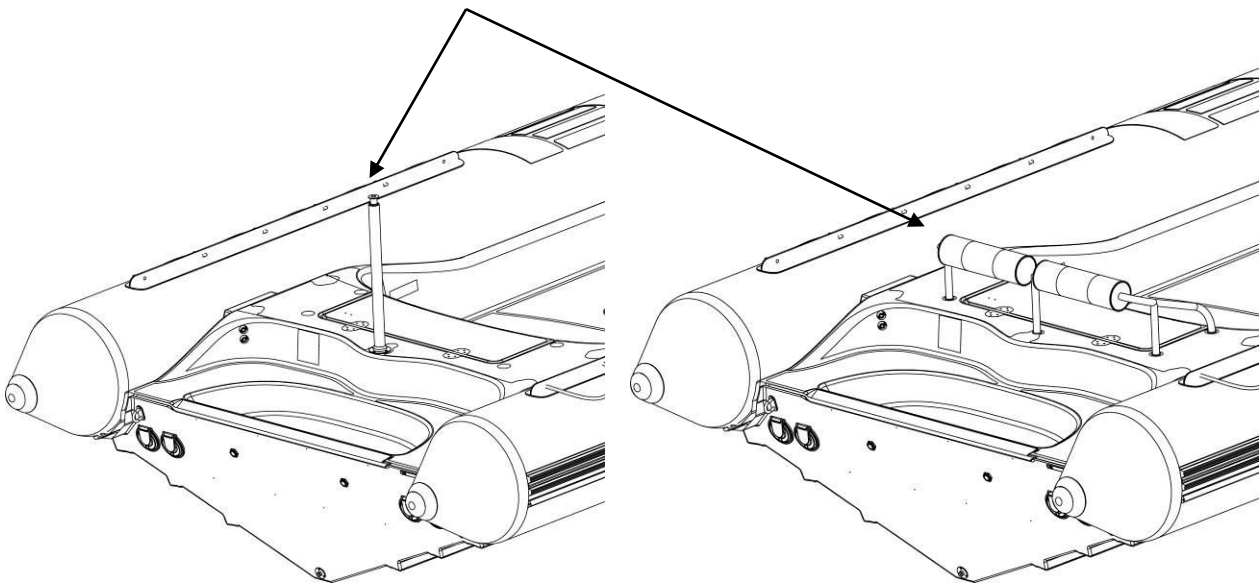

**DER SKIMAST KANN NUR FÜR WASSERSKI ODER WAKEBORD VERWENDET WERDEN. ZUM SCHLEPPEN VON BOOTEN ODER BEFESTIGEN AN BOJEN VERWENDEN SIE DIE IM HECKBEREICH BEFINDLICHEN BEFESTIGUNGSPUNKTE**

# EINBAUSTELLEN DES OPTIONALEN ZUBEHÖRS

VI-1-6-Einbaustelle T-TOP.

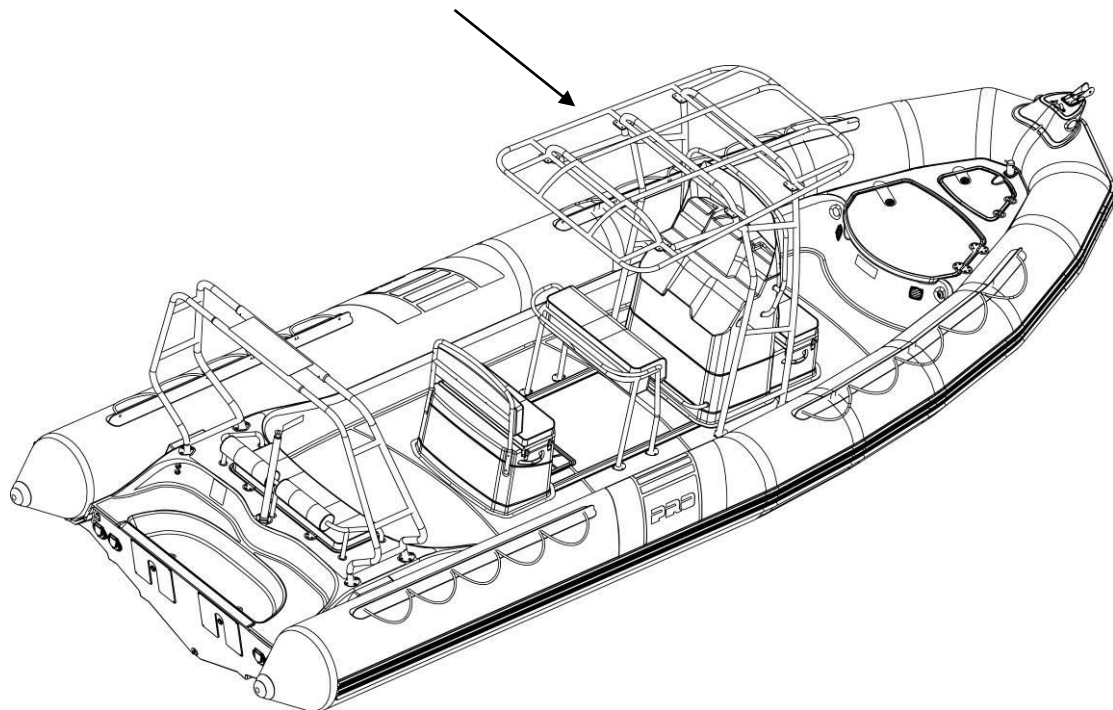





6-10 Rue Troyon  
92316- Sèvres - France

[www.zodiacmarine.com](http://www.zodiacmarine.com)

Pro 850

Code ZR20230

Edition 4