



Volume 2

***YACHTLINE
360/400***

611 133 - A



LIRE ATTENTIVEMENT CE MANUEL AVANT DE METTRE EN SERVICE VOTRE ZODIAC

TOME 2

DESCRIPTION - FLOTTEUR

SYSTEME DE PROPULSION





INSTALLATION ET CIRCUITS

SOMMAIRE



	PAGE
⇒ I - DESCRIPTIONS GENERALES	
I-1-Caractéristiques techniques -----	2 - 3
I-2-Inventaire -----	4 - 5
I-3-Localisation des éléments-----	6 - 7
I-4-Manutention -----	8 - 10
⇒ II - FLOTTEUR	
II-1-Grandes étapes de la mise en service du flotteur-----	11
II-2-Montage du flotteur sur la coque-----	12 - 13
II-3-Système de gonflage-----	14
II-4-Pression -----	14 - 16
⇒ III - SYSTEME DE PROPULSION	17
⇒ IV - INSTALLATION ET CIRCUITS	
IV-1-Installation de carburant -----	18 - 20
IV-2-Schéma électrique-----	21
IV-3-Batterie-----	22
IV-4-Stockage mât de feu de navigation-----	23
IV-5-Branchement d'options-----	24 - 26
IV-6-Fonctionnement pompe de cale-----	27



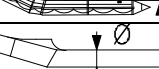

DESCRIPTION - Caractéristiques techniques

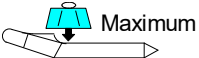

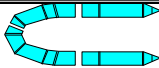
I-1-CARACTERISTIQUES TECHNIQUES

Dimensions			
		YL 360	YL 400
	(m)	3.60	4.00
	(ft)	11' 8"	13' 1"
	(m)	2	2.40
	(ft)	6' 7"	7' 10"
	(m)	1.77	1.77
	(ft)	5' 10"	5' 10"
	(m)	0.86	0.86
	(ft)	2' 10"	2' 10"
	(m)	0.455	0.455
	(ft)	1' 6"	1' 6"

Certification	
 (Directive 94/25/CE)	C

Capacité			
		YL 360	YL 400
 (ISO)		4	5
 Maximum	kg ⁽¹⁾	605	735
	lb ⁽¹⁾	1 334	1 621
	kg ⁽²⁾	200	218
	lb ⁽²⁾	441	481
 Compartment		3	3

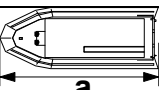
Motorisation			
		YL 360	YL 400
 Long			
	Puissance MINI recommandée	CV ⁽³⁾	15
		kW ⁽³⁾	12
	Puissance MAXI recommandée	CV	40
		kW	30
	Puissance MAXI autorisée	CV ⁽³⁾	40
		kW ⁽³⁾	30
 Maximum	Poids MAXI moteur	kg	119
		lb	262

Dimensions			
		YL 360	YL 400
 a	a ⁽⁴⁾	3.18 m	3.58 m
		10' 5"	11' 9"
 b	b ⁽⁴⁾	1.40 m	1.40 m
		4'6"	4'6"
 c	c ⁽⁴⁾	0.98 m	0.98 m
		3' 2"	3' 2"

DESCRIPTION - Caractéristiques techniques

NOTE	Tolérances sur les dimensions : +/- 4%
-------------	--

NOTE	<p>(1) La charge maximale autorisée a été calculée selon la norme ISO 6185. Il est recommandé de naviguer avec précaution lorsque le bateau est chargé au maximum.</p> <p>(2) Poids indiqués hors accessoires</p> <p>(3) Les puissances recommandées correspondent à une exploitation optimale des capacités du bateau pour une charge moyenne (4 personnes).</p> <p>(4) Dimensions de la coque sans flotteur.</p> <p>Utilisez la puissance maximale autorisée avec une extrême prudence (voir Tome 1 du manuel chapitre "Conseils de navigation").</p>
-------------	--

 ATTENTION	<p>La charge maximum indiquée sur la plaque constructeur ne doit pas être dépassée. La charge maximum comprend la masse du moteur, du carburant, des accessoires, des passagers et de leur équipement et tout autre type de chargement.</p>
--	--

 ATTENTION	<p>Ne pas stocker de produits inflammables dans le compartiment arrière. Le stockage d'un réservoir d'appoint est formellement interdit.</p>
---	---

UNIQUEMENT SUR 400DL :

 AVERTISSEMENT	<p>Manœuvrabilité limitée au-delà de 25 nœuds.</p> <p>Risque de perte de contrôle en cas de virages serres.</p> <p>Réduire la vitesse* avant d'effectuer des virages dans une direction quelconque.</p> <p>* vous pouvez également agir sur le power trim et rentrer le moteur vers le tableau.</p>
---	---

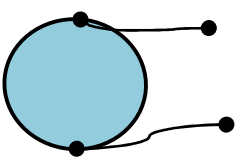
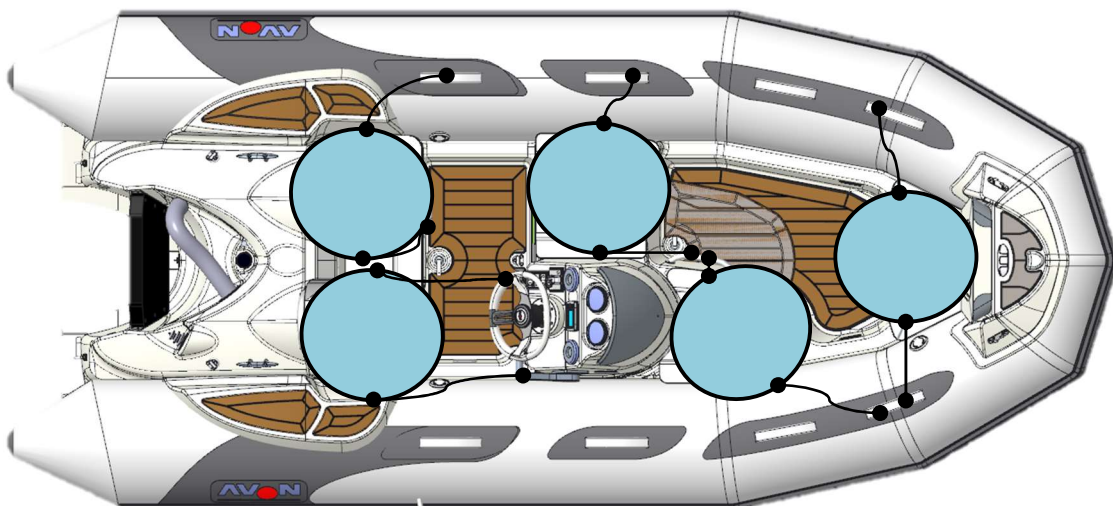

Assise avec prises de main pour le Yachtline 400

DESCRIPTION - Inventaire

I -2-INVENTAIRE

COQUE
• Coque polyester
• Pont contre-moulé antidérapant
• Tableau arrière rapporté et carène à « flaps »
• Console avec rangement
• 1 Anneau d'étrave
• 1 Coffre à mouillage + coffre devant console (uniquement sur 400 YL)
• 1 Coffre arrière
• 4 Sièges avec sellerie sur YL 360 (5 sièges sur 400 YL)
• 2 Taquets d'amarrage arrière
• 1 Marche pied polyester avant avec taquet d'amarrage feux de navigation et leds
• 1 Mât de feu blanc pliable et amovible
• 1 Lumière de pont
• 3 Cadènes articulées de levage
• 2 Cadènes de traction
• 2 Vide-vite + 1 Nable de coque

FLOTTEUR
• Flotteur amovible
• Tissu Hypalon-Néoprène 1100 decitex
• Valves Easy-Push
• Bande anti-ragage à profil large
• 6 Poignées
• Renforts de cônes

CONSOLE
• Volant et commande de direction à distance
• 3 Interrupteurs
• Boîte à gants

DESCRIPTION - Inventaire

EQUIPEMENT STANDARD
• 1 Réservoir fixe (35 litres + transmetteur jauge carburant + séparateur eau/essence) avec évent et dispositif anti-débordement
• Feux de navigation et lumières de pont
• 1 Bac à batterie
• 1 Coupe batterie
• Pré-équipement électrique pour ajout d'accessoires supplémentaires
• 1 Pompe de cale
• 2 Pagaies
• 1 Gonfleur à pied
• 1 Mallette de réparation
• 1 Manuel du propriétaire (2 tomes)
• 1 Bouchon manomètre

ACCESSOIRES EN OPTION
• Kit de levage
• Echelle de bain
• Dossier arrière
• Pont en teck synthétique
• Saute-vent

DESCRIPTION – Localisation des éléments

I-3-LOCALISATION DES ELEMENTS

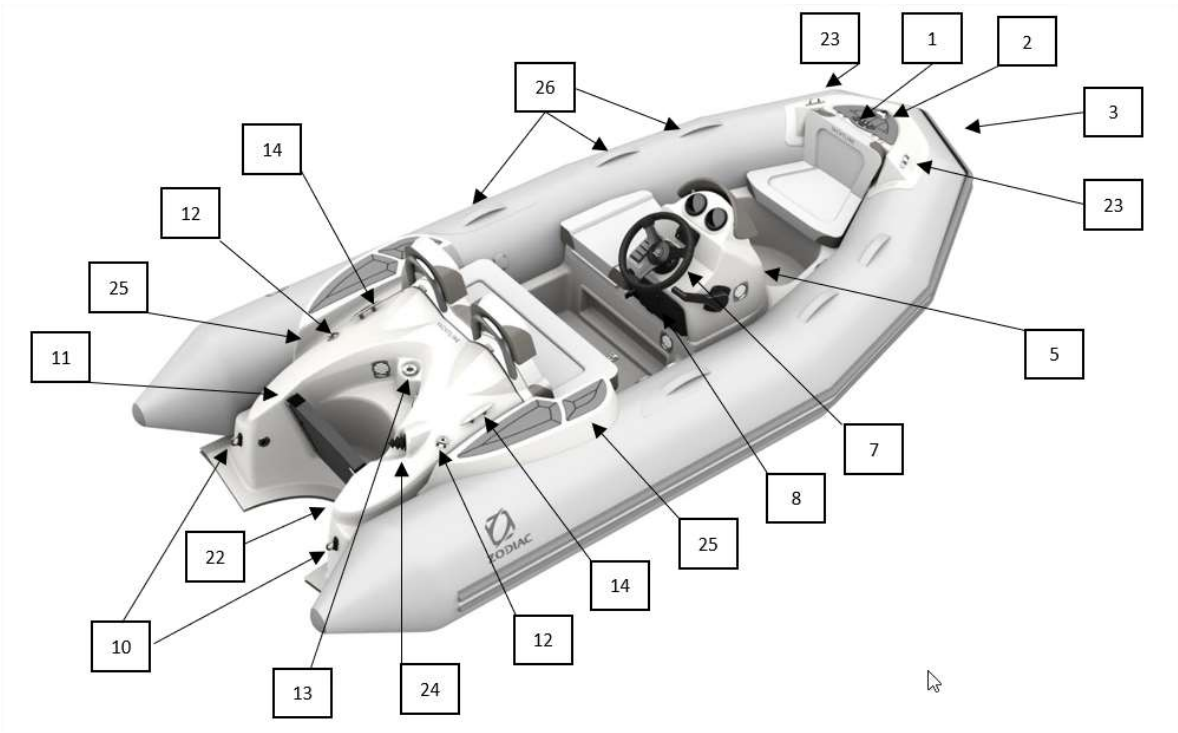

DESCRIPTION – Localisation des éléments

REPERE	DESIGNATION
1	Taquet d'amarrage avant
2	Feux de navigation
3	Marchepied polyester avant
4	Coffre à mouillage
5	Console
6	Interrupteurs
7	Volant
8	Boîte à gants
9	Siège arrière basculant
10	Anneaux de traction/d'arrimage
11	Tableau arrière
12	Anneaux de levage
13	Embase du mât de feu blanc
14	Taquets d'amarrage arrière
15	Système de remplissage réservoir
16	Trappe d'accès pour maintenance réservoir
17	Anneau d'étrave
18	Flotteur
19	Support extincteur
20	Vide-vite
21	Lumière de pont
22	Nable
23	Chaumard
24	Passe-câble
25	Marchepied polyester
26	Poignée
27	Valve Easy-Push
28	Prise allume-cigare 12V
29	Dossier arrière
30	Pont en teck synthétique
31	Saute-vent

DESCRIPTION - Manutention

I-4-MANUTENTION

I-4-1-Transport:

- Les conseils de la mise sur remorque sont spécifiés dans le manuel du propriétaire TOME I.

I-4-2-Stockage :

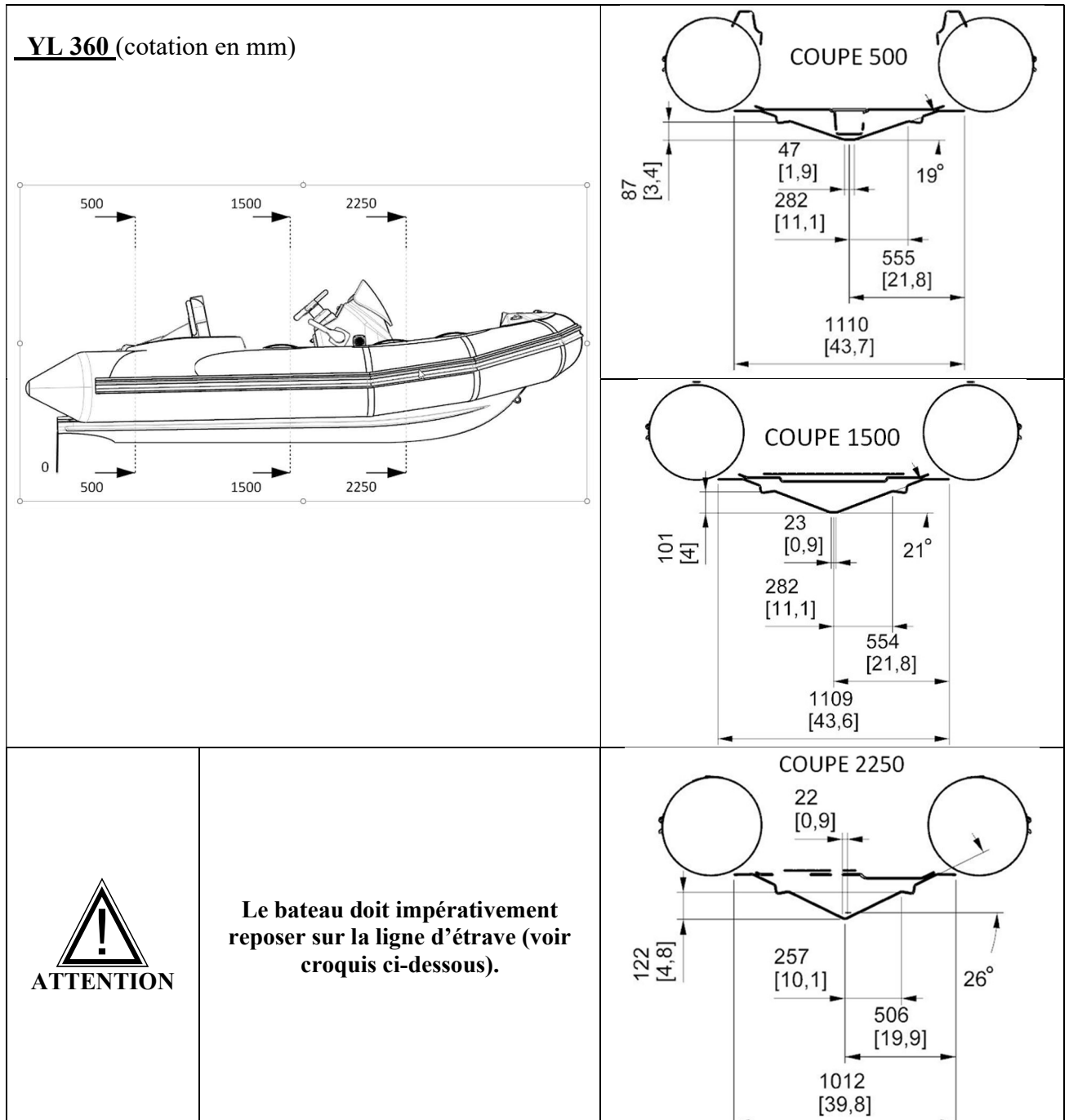

YL 400 (cotation en mm)

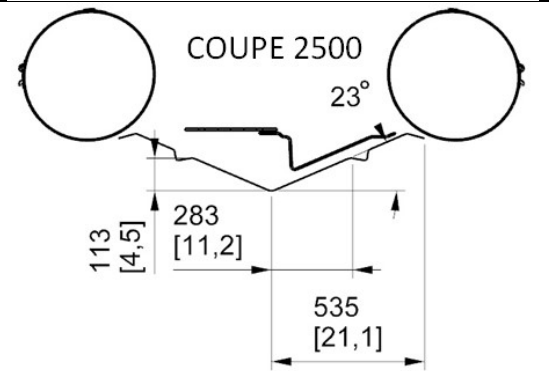
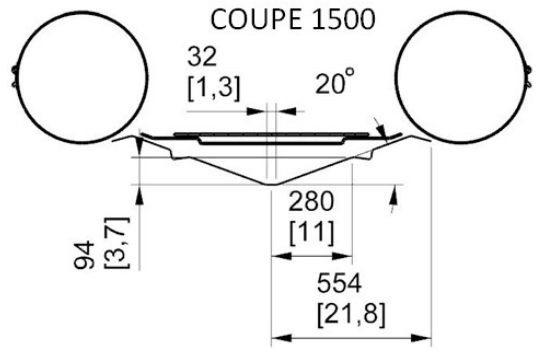
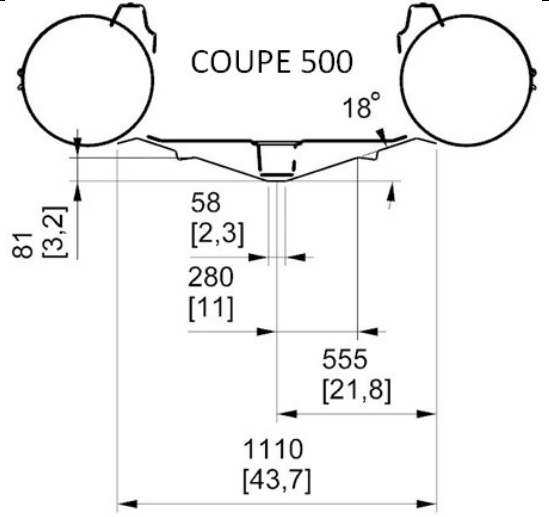
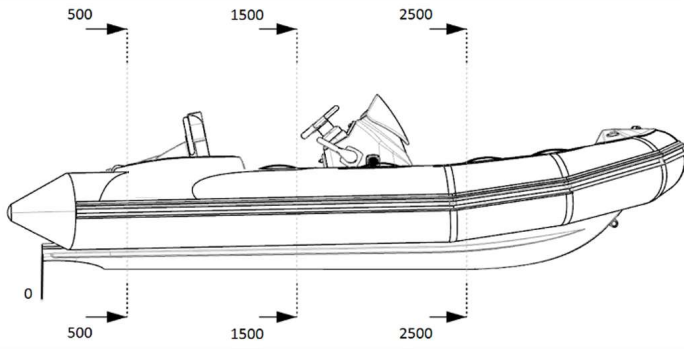

**Le bateau doit impérativement
reposer sur la ligne d'étrave (voir
croquis ci-dessous).**

DESCRIPTION - Manutention

I-4-3-Levage :

 AVERTISSEMENT	<p>L'élingue de levage est proposée en accessoire ; vous devez utiliser exclusivement une élingue Avon pour le levage.</p>
---	--

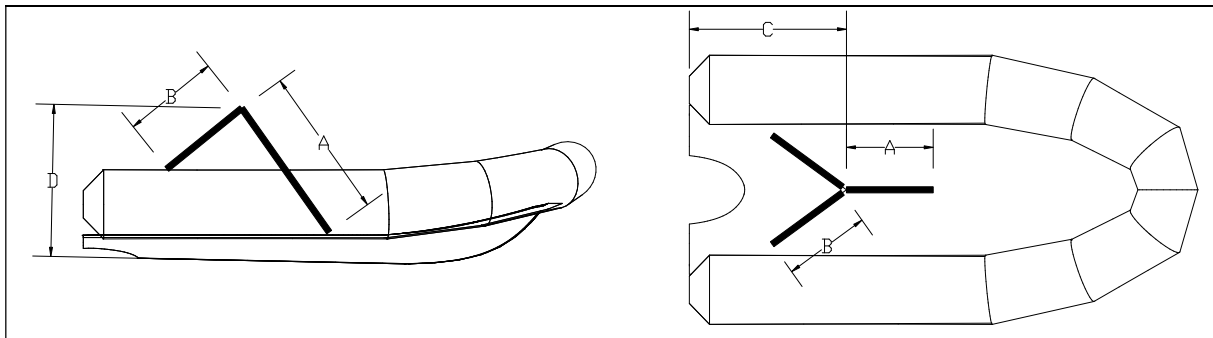

Ces valeurs sont données à titre indicatif		A	B	C	D
360 YL	(m)	1.25	1	1.45	1.4
	(ft)	4'1''	3'3''	4'8''	4'6''
400 YL	(m)	1.25	1	1.45	1.4
	(ft)	4'1''	3'3''	4'8''	4'6''

 AVERTISSEMENT	<p>Aucun passager à bord lors du grutage</p>
---	---

 ATTENTION	<ul style="list-style-type: none"> Le bateau doit être déchargé de tout matériel lors du grutage ou de la mise sous bossoirs. Les vide-vite de pont (rep 20*) et le nable (rep 22*) doivent être ouverts pour assurer l'évacuation éventuelle d'eau de pluie dans le cockpit. <p style="text-align: center; margin-top: 10px;">* voir chapitre I-3 « localisation des éléments »</p>
---	--

FLOTTEUR – Mise en service

II -1-GRANDES ETAPES DE LA MISE EN SERVICE DU FLOTTEUR

La procédure de montage du bateau suit un ordre que nous vous engageons à respecter. Procédez étape par étape en vous reportant à chaque fois aux pages indiquées pour les explications de procédure.

PROCEDURE	PAGE	SECTION
1. faites l’inventaire des éléments qui composent votre bateau, et apprenez à les reconnaître	4-5	Inventaire à l’ouverture
	6-7	Localisation des éléments
2. montez le flotteur sur la coque	11	Montage du flotteur
3. fixez la bavette interne	12	Fixation de la bavette
4. positionnez la bavette externe		
5. activez les valves en position de gonflage	14	Système de gonflage
6. procédez au gonflage du bateau aux pressions d’utilisation	15	Gonflage du bateau
	16-17	Pression
7. fixez la bavette externe	12	Fixation de la bavette

FLOTTEUR – Mise en service

II -2-MONTAGE DU FLOTTEUR SUR LA COQUE



SI LE FLOTTEUR A ETE STOCKE A UNE TEMPERATURE INFERIEURE A 0°C, LAISSEZ LE 12h DANS UN LIEU TEMPERE (20°C) AVANT DE LE DEPLIER.

NOTE

Le montage du flotteur sur la coque s'effectue flotteur **dégonflé**.

1

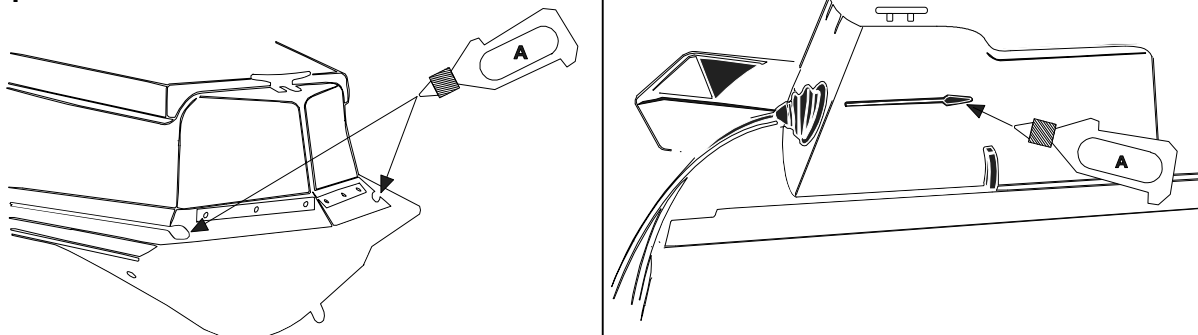

Pour faciliter la mise en place du flotteur, mettez du savon liquide (A) dans les rails de la coque

2

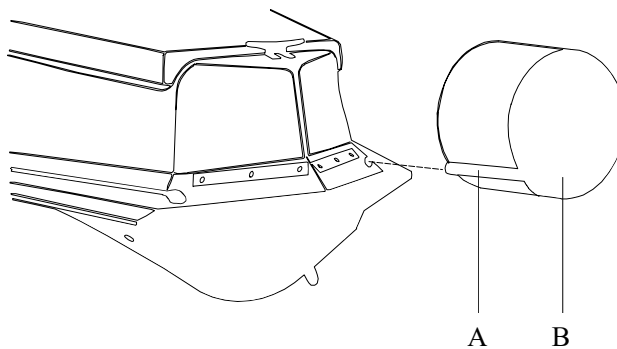

Positionnez la ralingue (a) du flotteur (b) dans le rail de la coque

3

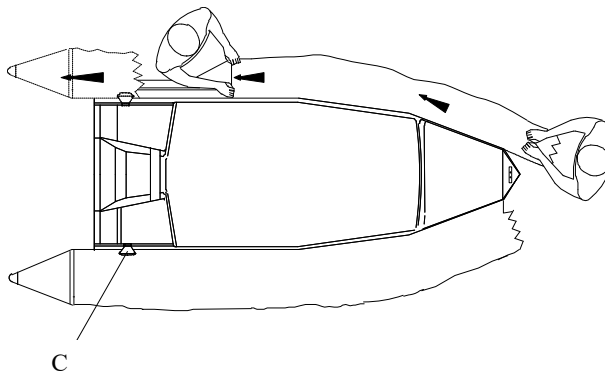

- Tirez le flotteur vers l'arrière du bateau (N'oubliez pas de guider la ralingue supérieure C).
- Procédez de la même façon pour l'autre côté du flotteur

FLOTTEUR - Mise en service

4

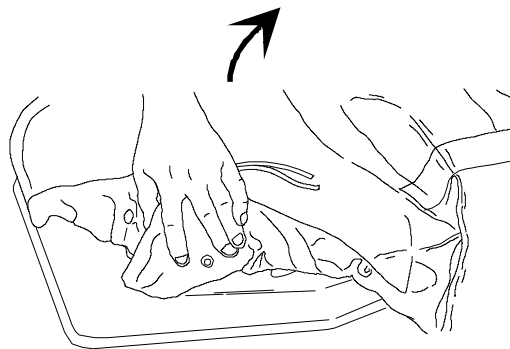

Mettez en place la bavette interne

5

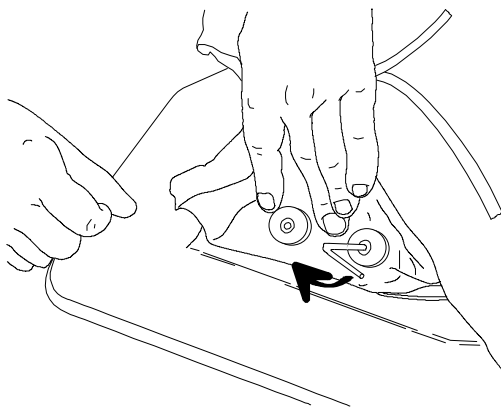

6

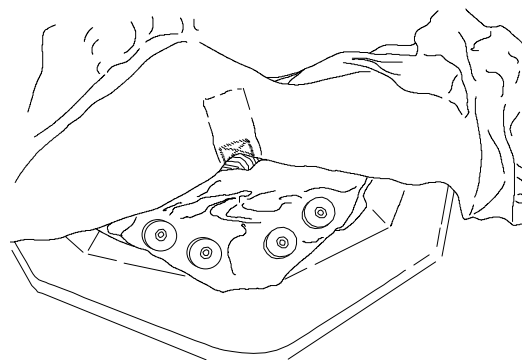

Fixez la bavette interne

7

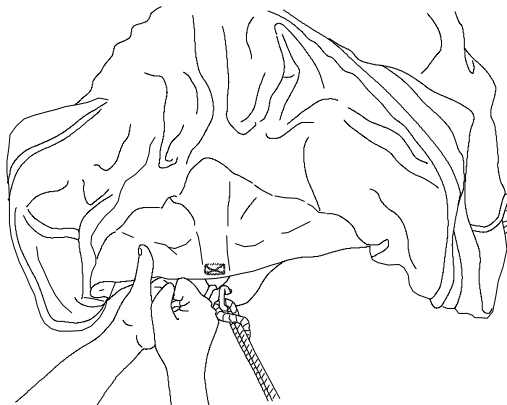

Après fixation de la bavette interne sur la coque, tirez légèrement le flotteur vers l'avant pour passer la bavette externe par-dessus la pointe avant (ne pas l'attacher à ce stade). Tirez ensuite le flotteur vers l'arrière.

NOTE

La fixation finale de la bavette **externe** doit être effectuée
après le gonflage du flotteur

PROCEDEZ ENSUITE AU GONFLAGE

FLOTTEUR - Système de gonflage

II -3-SYSTEME DE GONFLAGE

LE GONFLEUR

- a. adaptateur
- b. embout du tuyau
- c. embase du tuyau
- d. orifice de gonflage

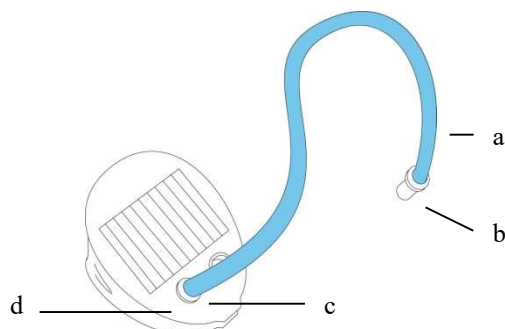

LES VALVES "EASY - PUSH"

Pour changer de position	en position de gonflage	en position de dégonflage
<p>Poussez</p>	<p>La membrane est fermée, le poussoir en position haute</p>	<p>La membrane est ouverte, le poussoir en position basse</p>

FLOTTEUR – Pression

GONFLAGE DU MOTEUR

Activez toutes les valves en position gonflage.

Fixez l'embase du tuyau à l'orifice de gonflage du gonfleur.
 Pour bien gonfler votre bateau, il faut que le gonfleur ait une bonne assise sur le sol.
 Le bateau se gonfle rapidement si le gonfleur est actionné en souplesse et sans précipitation.



Ne pas utiliser de compresseur ou de bouteille à air comprimé.

FLOTTEUR - Pression

GONFLAGE DU FLOTTEUR

- Ajoutez l'adaptateur correspondant au diamètre de la valve semi-encastrée à l'embout du tuyau du gonfleur.
- Procédez au gonflage du flotteur en équilibrant les pressions entre les différents compartiments, jusqu'à ce que les cloisons (a) ne soient plus visibles (pression = 240 mb)

	<p>Ne jamais mettre un compartiment sous pression les autres étant complètement dégonflés</p>	
--	---	--

	1	
--	---	--

	2	
--	---	--

Le gonflage est terminé : Vissez les bouchons des valves de gonflement.

NOTE :	<p>Il est normal de constater une légère fuite d'air avant le vissage du bouchon de valve.</p> <p>Seuls les bouchons assurent l'étanchéité finale.</p>
---------------	--

FLOTTEUR - Pression

PRESSION D'UTILISATION

La pression d'utilisation pour le flotteur est de 240 mb/ 3,4 PSI.

La température ambiante de l'air ou de l'eau influe proportionnellement sur le niveau de la pression interne du flotteur:	Température ambiante	Pression interne du flotteur
	+ 1° C	+ 4 mb / + 0,06 PSI
	- 1° C	- 4 mb / - 0,06 PSI

Aussi est-il important de savoir anticiper :
Vérifiez et ajustez la pression des compartiments gonflables (en regonflant ou en dégonflant selon le cas) en fonction des variations de température (surtout lorsque les

écarts de température sont importants entre le matin et le soir dans les zones particulièrement chaudes) et assurez-vous que la pression ne s'écarte pas de la zone de pression recommandée (de 220 à 270 mb / zone verte).

RISQUE DE SOUS-PRESSION :

EXEMPLE : Votre bateau est exposé sur la plage en plein soleil (température = 50° C) à la pression recommandée (240 mb/3,4 PSI). Lorsque vous le mettez à l'eau (température = 20° C), la température et la pression interne des compartiments gonflables vont conjointement baisser (jusqu'à 120 mb) et **IL VOUS FAUDRA ALORS REGONFLER** jusqu'à regagner les millibars perdus à cause de l'écart de température entre l'air ambiant et l'eau. Ainsi il est normal de constater une diminution de pression en fin de journée lorsque la température extérieure baisse.

RISQUE DE SURPRESSION :

EXEMPLE: Votre bateau est gonflé à sa pression recommandée (240 mb/3,4 PSI) en début ou fin de journée (température extérieure = 10° C). Plus tard dans la journée, votre bateau est exposé en plein soleil sur la plage ou sur le pont d'un yacht (température = 50° C). La température intérieure des compartiments gonflables peut alors s'élever et atteindre jusqu'à 70° C (flotteurs de couleur foncée notamment) entraînant un doublement de la pression de départ (480 mb). **IL VOUS FAUDRA ALORS DEGONFLER** afin de revenir à la pression recommandée.



Si votre bateau est trop gonflé, la pression sollicite de façon anormale la structure gonflable pouvant entraîner une rupture d'assemblage.

FLOTTEUR - Pression

EN CAS DE SURPRESSION

VALVE EASY-PUSH :
Libérez de l'air en appuyant sur le poussoir de la valve

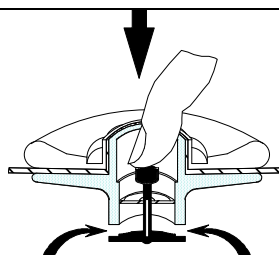

SYSTEME DE PROPULSION

III –Système de propulsion

Conformez-vous aux recommandations Zodiac et aux recommandations du constructeur de moteur.

Pour une utilisation optimale de votre embarcation, veuillez consulter votre concessionnaire.

INSTALLATION ET CIRCUIT – Carburant

IV -1-Installation de carburant

IV -1-1-Réservoir

Le réservoir se situe sous la console de pilotage :

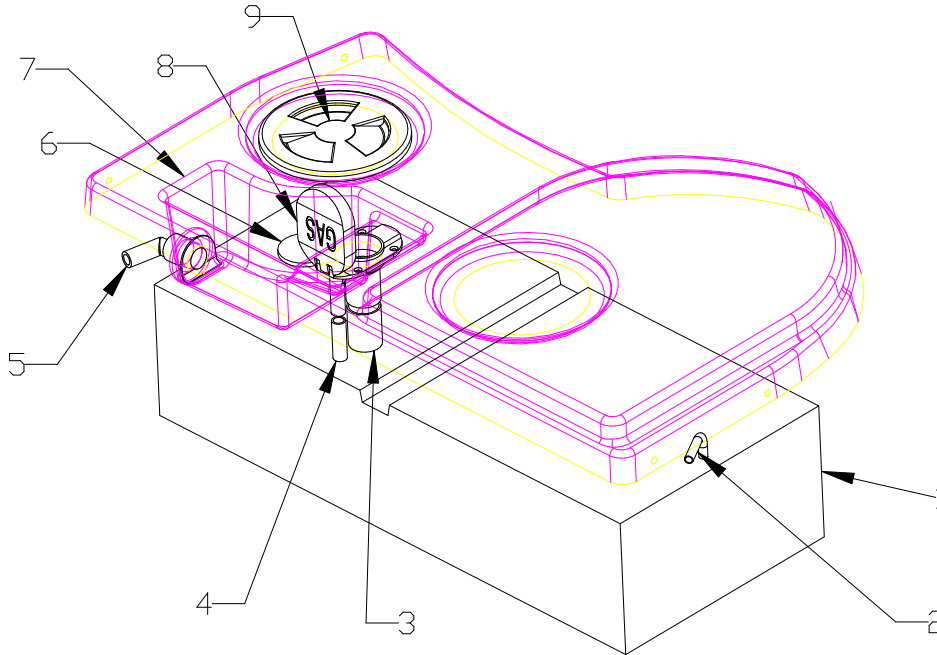

REPERE	DESIGNATION
1	Réservoir
2	Sortie pour alimentation moteur
3	Orifice de remplissage
4	Orifice d'évent
5	Nable de vidange du compartiment de « trop plein »
6	Transmetteur de jauge
7	Compartiment de « trop-plein »
8	Bouchon de remplissage avec évent intégré
9	Trappe de maintenance réservoir

 ATTENTION	<p>La présence du cadran de jauge est obligatoire. Celui-ci est fourni avec le moteur. En cas d'absence vous devez vous rapprocher de votre agent.</p>
---	---

La sonde est du type standard américain soit :

Impédance (position réservoir vide) 30 ohms

Impédance (position réservoir plein) 240 ohms

A de très rares exceptions, tous les cadrans du marché sont compatibles.

Pour le branchement, reportez-vous au schéma électrique page 22.

INSTALLATION ET CIRCUIT – Réservoir et accessoires

IV-1-2-Filtre séparateur eau/essence

NOTE :	Afin de protéger le moteur, un filtre séparateur d'eau /essence est placé sur le circuit d'alimentation essence du moteur.
---------------	---

Le filtre séparateur eau/essence se situe dans le coffre arrière, sur la paroi tribord :

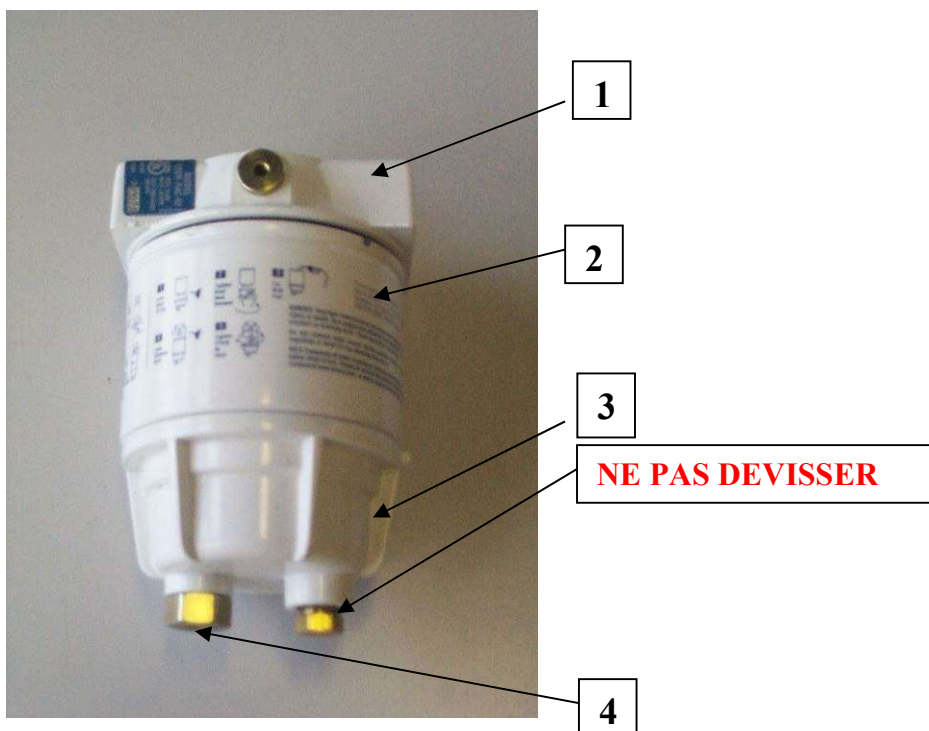

REPERE	DESIGNATION
1	Tête du filtre, fixée au bateau
2	Élément de filtration interchangeable
3	Bol métallique
4	Vis de purge

 AVERTISSEMENT	Ne dévissez pas la petite vis : vous pourriez endommager le joint et altérer l'étanchéité du bol.
--------------------------	--

NOTE	Vérifiez, à chaque utilisation, l'absence d'eau dans le bol métallique : Dévissez légèrement le bouchon de vidange (ne pas l'enlever complètement) ; vidangez l'eau ; revissez le bouchon s'il n'y a que de l'essence dans le bol. Renouvelez l'opération plus souvent si votre moteur ne fonctionne pas correctement.
-------------	---

INSTALLATION ET CIRCUIT – Réservoir et accessoires

 AVERTISSEMENT	<p>Il est indispensable de purger et nettoyer régulièrement le filtre et de changer la cartouche au moins une fois par an. Le bol métallique est réutilisable.</p>
---	--

Changement de la cartouche du filtre :

Conformez-vous aux recommandations ZODIAC et aux recommandations du constructeur du filtre.



IV-1-3-Recommandations :

 AVERTISSEMENT	<ul style="list-style-type: none"> <input checked="" type="checkbox"/> Un réservoir plein évite la condensation à chaque sortie. <input checked="" type="checkbox"/> Faites nettoyer le réservoir tous les 5 ans. <input checked="" type="checkbox"/> Vérifiez le serrage des colliers sur toutes les durites. <input checked="" type="checkbox"/> Lorsque vous purgez le filtre, ne videz pas l'eau dans le bateau. Utilisez un bac de récupération sous le filtre. <input checked="" type="checkbox"/> Coupez le contact avant de démonter la cartouche du filtre. <input checked="" type="checkbox"/> Lire attentivement les instructions sur la notice du filtre.
---	---

 AVERTISSEMENT	<ul style="list-style-type: none"> <input checked="" type="checkbox"/> L'essence est extrêmement inflammable. Lorsque vous devez intervenir sur le système de carburation, assurez-vous que les moteurs soient arrêtés. Ne pas fumer ; éloigner toute flamme ou corps incandescent de la zone de travail.
---	---

INSTALLATION ET CIRCUIT – Electricité

IV -2-SCHEMA ELECTRIQUE

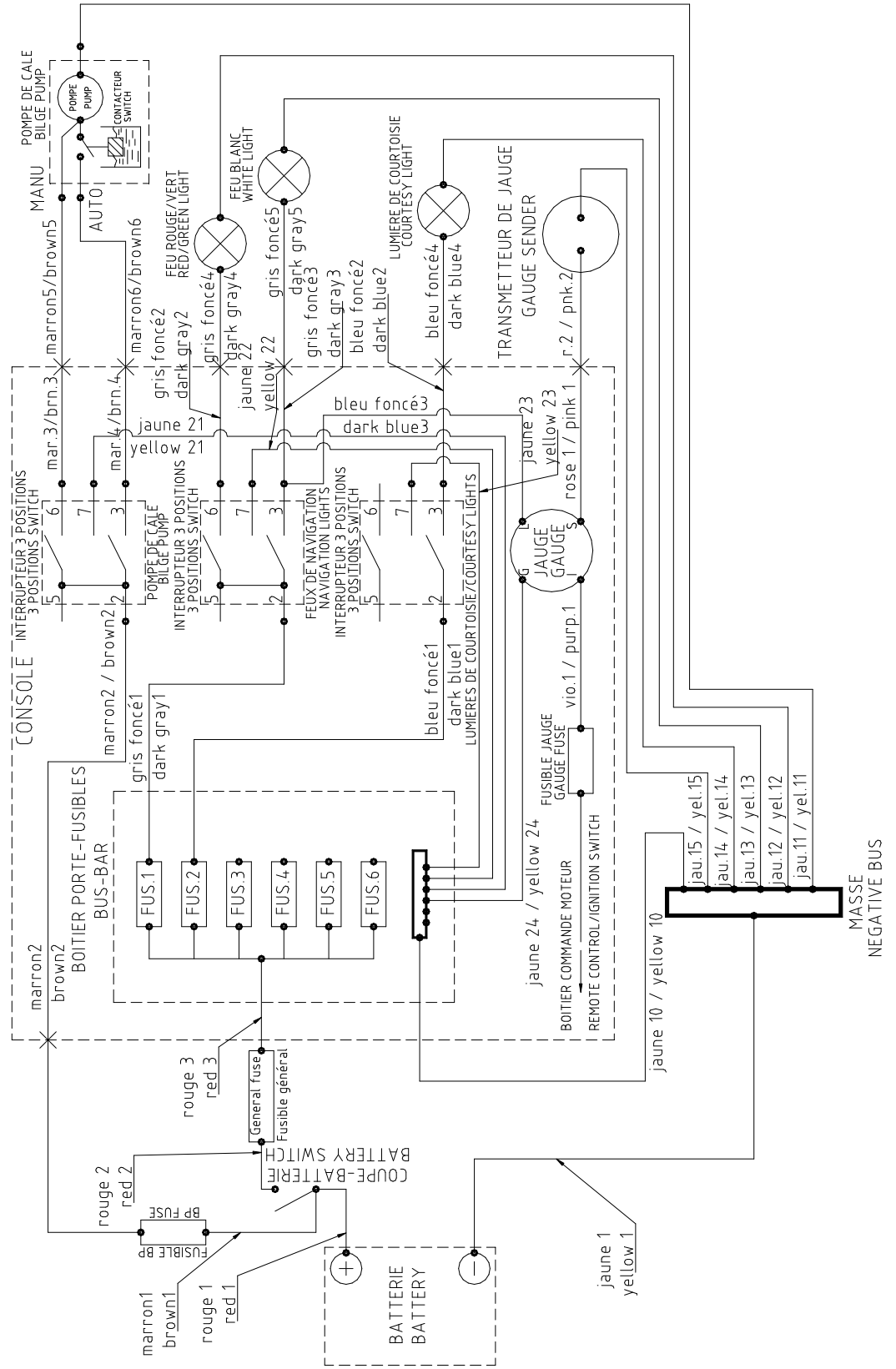



INSTALLATION ET CIRCUIT – Branchement d'options

IV -3-BATTERIE (non fournie)

Conformez-vous aux recommandations Zodiac et aux recommandations du fabricant de batteries pour l'entretien courant.

	<p>Entretenez votre batterie :</p> <ul style="list-style-type: none"><input checked="" type="checkbox"/> Maintenez la batterie propre et sèche afin d'éviter une usure prématurée.<input checked="" type="checkbox"/> Resserrez et entretenez les cosses sur borne en les graissant régulièrement.
---	---

 ATTENTION	<p>L'eau provenant du système d'adduction d'eau contient des minéraux qui endommagent les batteries. Faites donc toujours l'appoint avec de l'eau distillée.</p>
 AVERTISSEMENT	<ul style="list-style-type: none">• Maintenir les batteries et l'électrolyte hors de portée des enfants• Ne couchez jamais la batterie.• Lorsque vous rajoutez de l'électrolyte ou que vous rechargez la batterie, retirez-la toujours du compartiment moteur• L'électrolyte de batterie est un liquide toxique et dangereux. Il contient de l'acide sulfurique, qui peut provoquer de graves brûlures. Evitez tout contact avec la peau, les yeux et les vêtements.• Les batteries peuvent dégager des gaz explosifs. Eloignez les sources d'étincelles, les flammes nues, les cigarettes, etc.• Lorsque vous chargez ou utilisez une batterie, opérez en un endroit bien ventilé. Protégez toujours vos yeux lorsque vous travaillez à proximité d'une batterie.

NOTE :	<ul style="list-style-type: none"><input checked="" type="checkbox"/> Lorsque vous n'utilisez pas votre annexe Zodiac pendant un mois ou plus, retirez la batterie et rangez-la dans un endroit frais, sombre et sec. Rechargez complètement la batterie avant de la réutiliser<input checked="" type="checkbox"/> Si la batterie doit être remise pendant une période plus longue, vérifiez la densité de l'électrolyte au moins une fois par mois et rechargez la batterie dès que la densité est trop basse. <p>Densité de l'électrolyte : 1,28 à 20°C</p>
---------------	--

NOTE :	<p>Lorsque vous n'utilisez plus votre bateau, mettez le coupe-circuit sur la position OFF.</p>
---------------	--

INSTALLATION ET CIRCUIT – Branchement d’options

IV -4-STOCKAGE DU MAT DE FEU DE NAVIGATION



 AVERTISSEMENT	<p>Pour ne pas endommager le mat de feu de navigation à la fermeture de l’assise, veuillez à toujours le fixer comme indiqué sur la photo ci-dessus.</p>
---	---

NOTE	<p>Pour faciliter le rangement du mât dans ses plots de fixation, il est possible d’appliquer de l’eau savonneuse.</p>
-------------	---

VUE DE DESSUS :

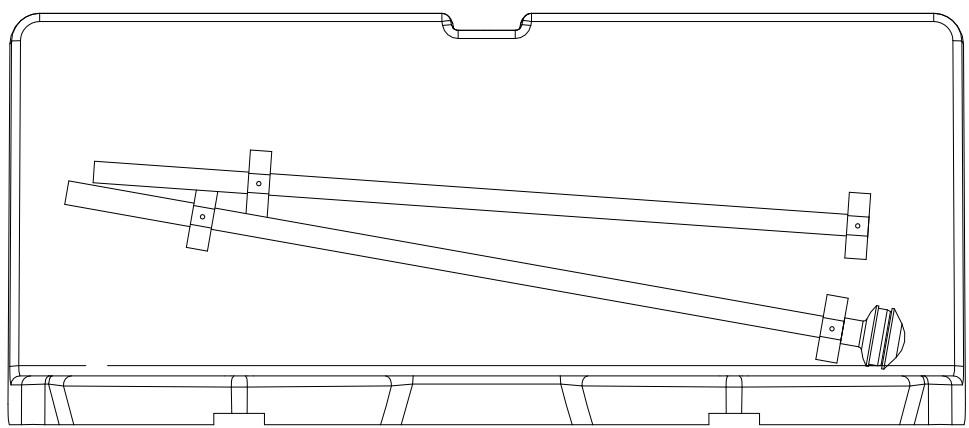

INSTALLATION ET CIRCUIT – Branchement d'options

IV -5-BRANCHEMENT D'OPTIONS

IV -5-1-Précautions :

Le bateau est équipé de série d'une pompe de cale, des feux de navigation et d'une lumière de pont. Cependant, 4 emplacements restent disponibles sur le boîtier à fusibles (sous la console) pour le branchement d'accessoires supplémentaires sous certaines conditions :

- ① Les accessoires que voulez rajouter devront être branchés au niveau de la console.
- ② Les accessoires se partagent deux catégories :
 - A → les accessoires qui sont utilisés ou qui sont susceptibles d'être utilisés en continu lors d'une utilisation normale du bateau,
 - B → les accessoires qui sont utilisés de façon intermittente.

A		et	B	
Ventilateur de cale			Prise allume cigare	
Radio			Eclairage divers	
Sondeur			Avertisseur sonore	
GPS			Equipement électronique divers	
Projecteur			Pompe de douche	
Système d'alarme			Puissance maxi retenue	72 W maxi
Réfrigérateur				
VHF				
Σ	180 W maxi			

 AVERTISSEMENT	<p>Vous devez impérativement vous assurer que la somme des puissances des accessoires de la colonne A que vous <u>rajoutez</u> est inférieure ou égale à 180 W (15 A) <u>ET</u> que la puissance maxi d'un accessoire de la colonne B est inférieure ou égale à 72 W (6 A).</p> <p>Les sections des différents câbles du faisceau ont été calculées avec ces valeurs ; le non-respect de cette règle peut engendrer des dysfonctionnements électriques et causer des courts-circuits.</p>
---	---

NOTE :	<p>Si vous faites installer de nombreux équipements électriques. La consommation instantanée totale pourra éventuellement dépasser la capacité de charge de votre moteur hors-bord. Par exemple, le faisceau électrique peut accepter une consommation instantanée de 285 W (feux de navigation et pompe de cale compris), soit un peu moins de 24 A en débit de courant. Les alternateurs des moteurs actuels fournissent en général une intensité de 15 A, à plein régime (A vérifier dans la documentation technique de votre moteur). Vous devez donc éviter une utilisation prolongée de ces appareils, au risque de vider votre batterie et ne pas pouvoir redémarrer votre moteur.</p>
---------------	--

INSTALLATION ET CIRCUIT – Branchement d’options

Exemple 1

Vous voulez rajouter :
 Une VHF de 72 W,
 Un GPS de 36 W,
 Une radio de 60 W,
 Un allume cigare de 72 W,
 Une montre de 20 W.

A	
Ventilateur de cale	
Radio	60 W
Sondeur	
GPS	36 W
Projecteur	
Système d’alarme	
Réfrigérateur	
VHF	72 W
Σ	168 W (<180 W) ☺

et

B	
Eclairage divers	
Equipement électronique divers	20 W (montre)
Pompe de douche	
Puissance maxi retenue	20 W (< 72 W) ☺

CONCLUSION	
------------	--

Exemple 2

Vous voulez rajouter :
 Une VHF de 60 W,
 Un GPS de 36 W,
 Une radio de 48 W,
 Un projecteur de 120 W.

A	
Ventilateur de cale	
Radio	48 W
Sondeur	
GPS	36 W
Projecteur	120 W
Système d’alarme	
Réfrigérateur	
VHF	60 W
Σ	264 W (> 180 W) ☹

et

B	
Eclairage divers	
Equipement électronique divers	
Pompe de douche	
Puissance maxi retenue	0 (< 72 W) ☹

CONCLUSION	
------------	---

INSTALLATION ET CIRCUIT – Branchement d'options

Exemple 3

Vous voulez rajouter :
 Un GPS de 60 W,
 Une radio de 60 W,
 Un avertisseur sonore de 120 W.

A	
Ventilateur de cale	
Radio	60 W
Sondeur	
GPS	60 W
Projecteur	
Système d'alarme	
Réfrigérateur	
VHF	
Σ	120 W (< 180 W) ☺

et

B	
Eclairage divers	
Equipement électronique divers	120 W
Pompe de douche	
Puissance maxi retenue	120 W (> 72 W) ☹

CONCLUSION	
------------	---

NOTE	Certains fabricants vous donneront l'ampérage au lieu de la puissance absorbée. En courant continu avec une batterie 12 V (c'est le cas ici), il suffit de multiplier par 12 pour obtenir la puissance.
-------------	--

IV -5-2-Cablage :

- ① Choisir un emplacement de fusible libre,
- ② Connecter le câble d'alimentation de votre accessoire sur la borne correspondante à cet emplacement avec une «cosse languette» femelle de 6mm,
- ③ Si vous devez rajouter du câble pour le branchement, utiliser du câble de section mini 1.5mm² et respectant les recommandations en matière de câble « marine » (UL1426 ou SAE J378 ou SAE J1127 ou SAE J1128 ou d'une manière générale répondant aux recommandations ABYC et/ou CE),
- ④ Connecter le câble de masse de votre accessoire sur le bornier de masse avec une «cosse à œil» Ø5 (même remarque que précédemment pour le câble),
- ⑤ Insérer un fusible de type ATO d'intensité maxi de 15A et supérieure à l'intensité d'utilisation de votre appareil.

IV -5-3-Branchement jauge à essence :

Brancher suivant indications du schéma (page 19).

INSTALLATION ET CIRCUIT – Branchement d’options

IV -5-4-Installation des accessoires sur la console :

En fonction du niveau d’équipement de votre annexe, ZODIAC recommande la disposition suivante (voir gabarits de perçage livrés avec le bateau) qui optimise l’espace disponible.

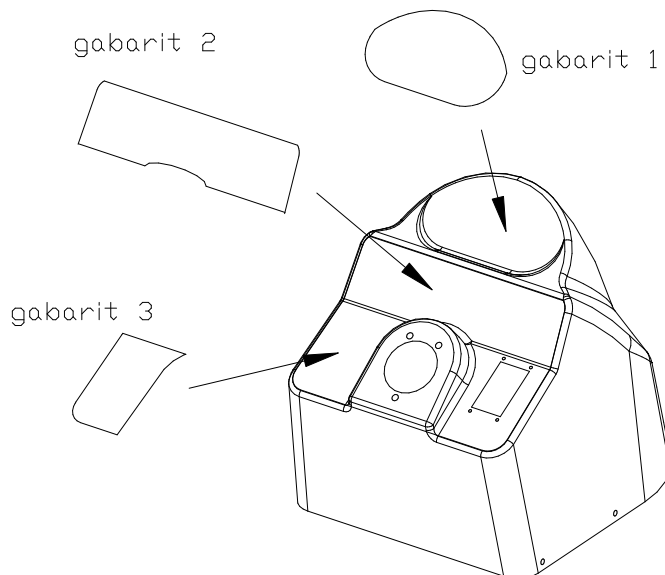

IV -6-FONCTIONNEMENT DE LA POMPE DE CALE

Le fonctionnement de la pompe de cale est indépendant de la position du coupe-batterie ; l’interrupteur de commande  est toujours sous tension.

- ① Marche automatique (position fixe) : dans cette position, le fonctionnement de la pompe de cale est automatique. Le voyant est allumé.
- ② Arrêt : dans cette position (position fixe), la pompe de cale est arrêtée. Le voyant est éteint.
- ③ Marche forcée : il faut maintenir l’interrupteur appuyé pour obtenir un fonctionnement en marche forcée. Dès que vous relâchez le doigt, l’interrupteur revient en position arrêt (2).

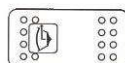

 AVERTISSEMENT	<p>Au mouillage, mettre l’interrupteur de pompe de cale sur la position marche automatique.</p>
---	--

NOTE	<p>Zodiac recommande l’usage d’une bâche ou d’un taud de mouillage afin de prévenir les entrées d’eau en cas de pluie.</p>
-------------	---



AVERTISSEMENT

L'attention est attirée sur le processus de finition dans lequel des éléments structurels, tels que par exemple les consoles de direction, des sièges et superstructures, sont installés par d'autres parties que le fabricant du bateau. Il convient que ces éléments soient installés de manière à être conformes aux exigences pertinentes de l'ISO 6185-3 afin de garantir que toutes ces installations n'invalident pas l'évaluation initiale.

Assurez-vous également que l'installation postérieure de consoles et autres éléments de structure non initialement fournis avec le bateau soit effectuée conformément aux conseils d'installation fournis par le constructeur et aux préconisations de ZODIAC.



Volume 2

***YACHTLINE
360 / 400***

611 133 A



CAREFULLY READ THIS MANUAL BEFORE PUTTING YOUR ZODIAC INTO SERVICE.

VOLUME 2





DESCRIPTION - BUOYANCY TUBE PROPULSION SYSTEM INSTALLATION AND CIRCUITS

CONTENTS



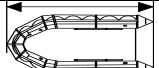
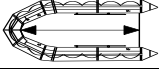

	PAGE
⇒ I - GENERAL DESCRIPTION	
I-1-Technical characteristics-----	2 - 3
I-2-Inventory-----	4 - 5
I-3-Location of parts-----	6 - 7
I-4-Handling-----	8 - 10
⇒ II - BUOYANCY TUBE	
II-1-Major stages in fitting the buoyancy tube-----	11
II-2-Installing the buoyancy tube on the hull-----	12 - 13
II-3-Inflation system-----	14
II-4-Pressure -----	14 - 16
⇒ III - PROPULSION SYSTEM	17
⇒ IV - INSTALLATION AND CIRCUITS	
IV-1-Fuel installation-----	18 - 20
IV-2-Electrical diagram-----	21
IV-3-Battery-----	22
IV-4-Storage of navigation light mast-----	23
IV-5-Connection of options-----	24 - 26
IV -6-Bilge pump operation-----	27





DESCRIPTION - TECHNICAL CHARACTERISTICS

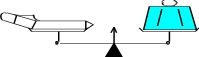

I-1-TECHNICAL CHARACTERISTICS

Dimensions			
		YL 360	YL 400
	(m)	3.60	4.00
	(ft)	11' 8"	13' 1"
	(m)	2	2.40
	(ft)	6' 7"	7' 10"
	(m)	1.77	1.77
	(ft)	5' 10"	5' 10"
	(m)	0.86	0.86
	(ft)	2' 10"	2' 10"
	(m)	0.455	0.455
	(ft)	1' 6"	1' 6"

Certification	
 (Directive 94/25/EU)	C

Capacity			
		YL 360	YL 400
 (ISO)		4	5
 Maximum	kg ⁽¹⁾	605	735
	lb ⁽¹⁾	1,334	1,621
 Maximum	kg ⁽²⁾	200	218
	lb ⁽²⁾	441	481
 Compartment		3	3

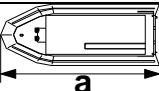
Engine			
		YL 360	YL 400
	Minimum recommended power	HP ⁽³⁾	15
		kW ⁽³⁾	12
	Maximum recommended power	HP	40
		kW	30
	Maximum allowed power	HP ⁽³⁾	40
		kW ⁽³⁾	30
 Maximum	Maximum engine weight	kg	119
		lb	262

Dimensions			
		YL 360	YL 400
	a ⁽⁴⁾	3.18 m	3.58 m
		10' 5"	11' 9"
	b ⁽⁴⁾	1.40 m	1.40 m
		4' 6"	4' 6"
	c ⁽⁴⁾	0.98 m	0.98 m
		3' 2"	3' 2"

DESCRIPTION - TECHNICAL CHARACTERISTICS

NOTE	Dimension tolerance: +/- 4%
-------------	-----------------------------

NOTE	<p>(1) The maximum payload has been calculated according to ISO 6185 standards. We recommend that you exercise caution when the boat is at maximum capacity.</p> <p>(2) The weights indicated do not include any accessories</p> <p>(3) The recommended power corresponds to optimal use of the boat's capacities for an average load (4 people).</p> <p>(4) Hull dimensions without buoyancy tube.</p> <p>Use the maximum authorized power with extreme caution (see "Recommended operating procedure" chapter of Volume 1 of the manual.)</p>
-------------	---

 WARNING	<p>The maximum load on the manufacturer's plate should not be exceeded. The maximum load includes the weight of the engine, fuel, accessories, passengers and their equipment and any other type of load.</p>
--	---

 WARNING	<p>Do not store flammable products in the rear compartment. It is strictly forbidden to store a spare fuel tank.</p>
---	--

ONLY ON 400DL:

 WARNING	<p>Limited manoeuvrability at speeds above 25 knots.</p> <p>Risk of loss of control in tight turns.</p> <p>Reduce speed* before turning in any direction.</p> <p>* you can also vary the power trim and move the engine closer to the transom.</p>
---	--

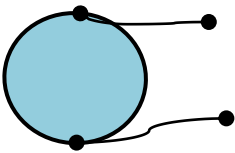
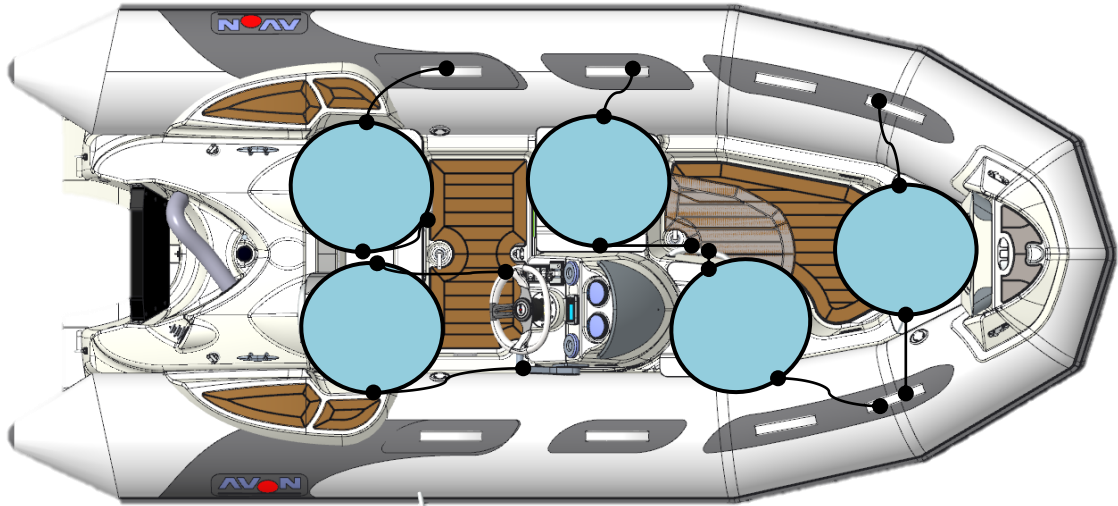

Seat with handles for the Yachtline 400

DESCRIPTION - INVENTORY

I-2-INVENTORY

HULL
• Polyester hull
• Counter-moulded, anti-slip deck
• Added transom and "flap" hull shape
• Console with storage
• 1 bow ring
• 1 anchor locker + locker forwards of the console (only on the 400 YL)
• 1 Aft locker
• 4 upholstered seats on YL 360 (5 seats on 400 YL)
• 2 aft anchoring cleats
• 1 front polyester step with cleat, navigation lights and LEDs
• 1 Folding and removable mast for white light
• 1 Deck light
• 3 Hinged lifting chain plates
• 2 Towing chain plates
• 2 Self-bailers + 1 Hull drain hole

BUOYANCY TUBE
• Removable buoyancy tube
• Hypalon-Neoprene 1100 decitex fabric
• Easy-Push valves
• Broad rubbing strip
• 6 Handles
• Cone reinforcements

CONSOLE
• Steering wheel and remote steering control
• 3 Switches
• Glove compartment

DESCRIPTION - Inventory

STANDARD EQUIPMENT
• 1 Fixed tank (35 litres + fuel gauge transmitter + water/fuel separator) with vent and anti-overflow device
• Navigation lights and deck lights
• 1 battery tray
• 1 battery isolation switch
• Pre-fitted electric equipment to add extra accessories
• 1 Bilge pump
• 2 Paddles
• 1 Foot inflator
• 1 Repair kit
• 1 Owner's manual (2 volumes)
• 1 Pressure gauge cap

OPTIONAL ACCESSORIES
• Lifting kit
• Boarding ladder
• Rear seatback
• Synthetic teak deck
• Wind deflector

DESCRIPTION – LOCATION OF ITEMS

I-3- LOCATION OF PARTS

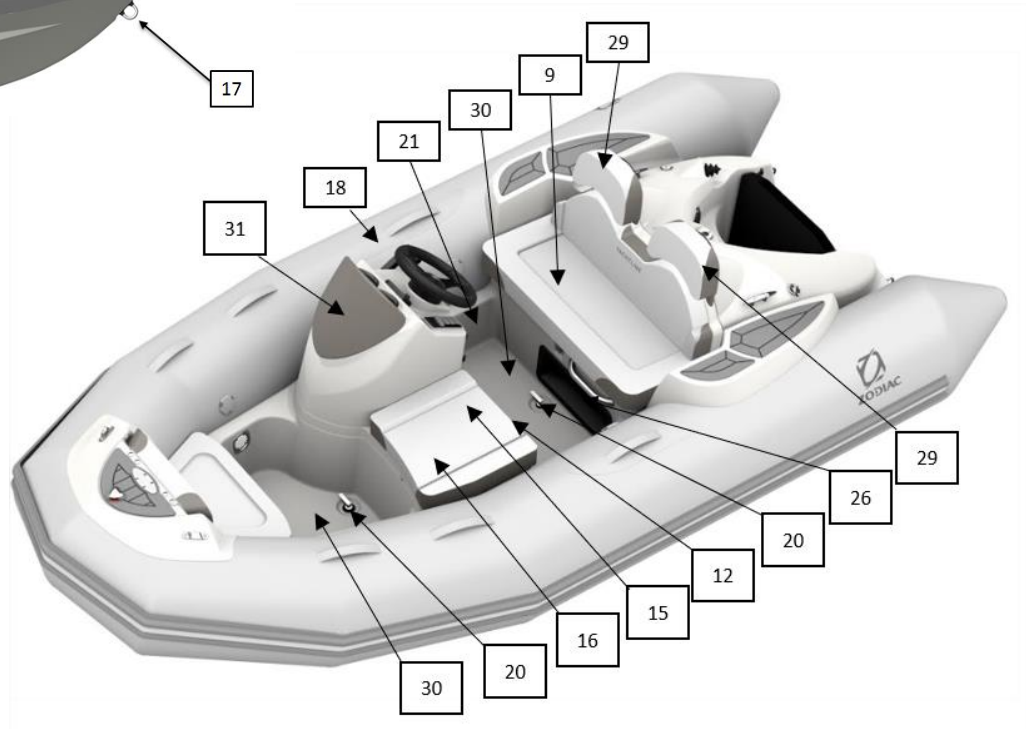
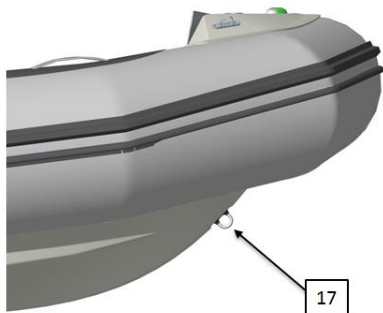
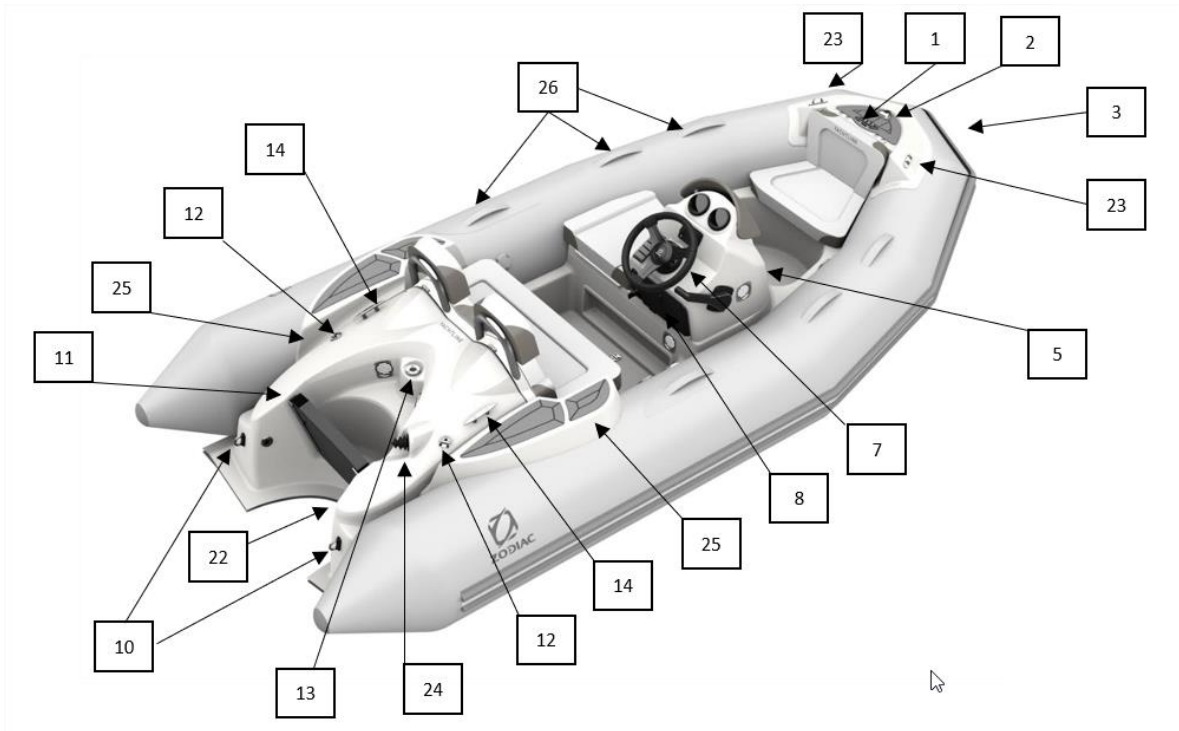

DESCRIPTION – LOCATION OF ITEMS

REF.	DESCRIPTION
1	Forward mooring cleat
2	Navigation lights
3	Front polyester step
4	Anchor locker
5	Console
6	Switches
7	Steering wheel
8	Glove compartment
9	Tilting aft seat
10	Towing / mooring rings
11	Transom
12	Lifting rings
13	Base of white light mast
14	Aft anchoring cleats
15	Tank filling system
16	Tank maintenance access hatch
17	Bow ring
18	Buoyancy tube
19	Fire extinguisher bracket
20	Self-bailer
21	Deck light
22	Scupper
23	Fairlead
24	Cable pull
25	Polyester step
26	Handle
27	Easy-Push valve
28	12V - cigarette lighter
29	Rear seatback
30	Synthetic teak deck
31	Wind deflector

DESCRIPTION - HANDLING

I-4-HANDLING

I-4-1 Transport:

- The trailer installation recommendations are specified in VOLUME I of the owner's manual.

I-4-2 Storage:

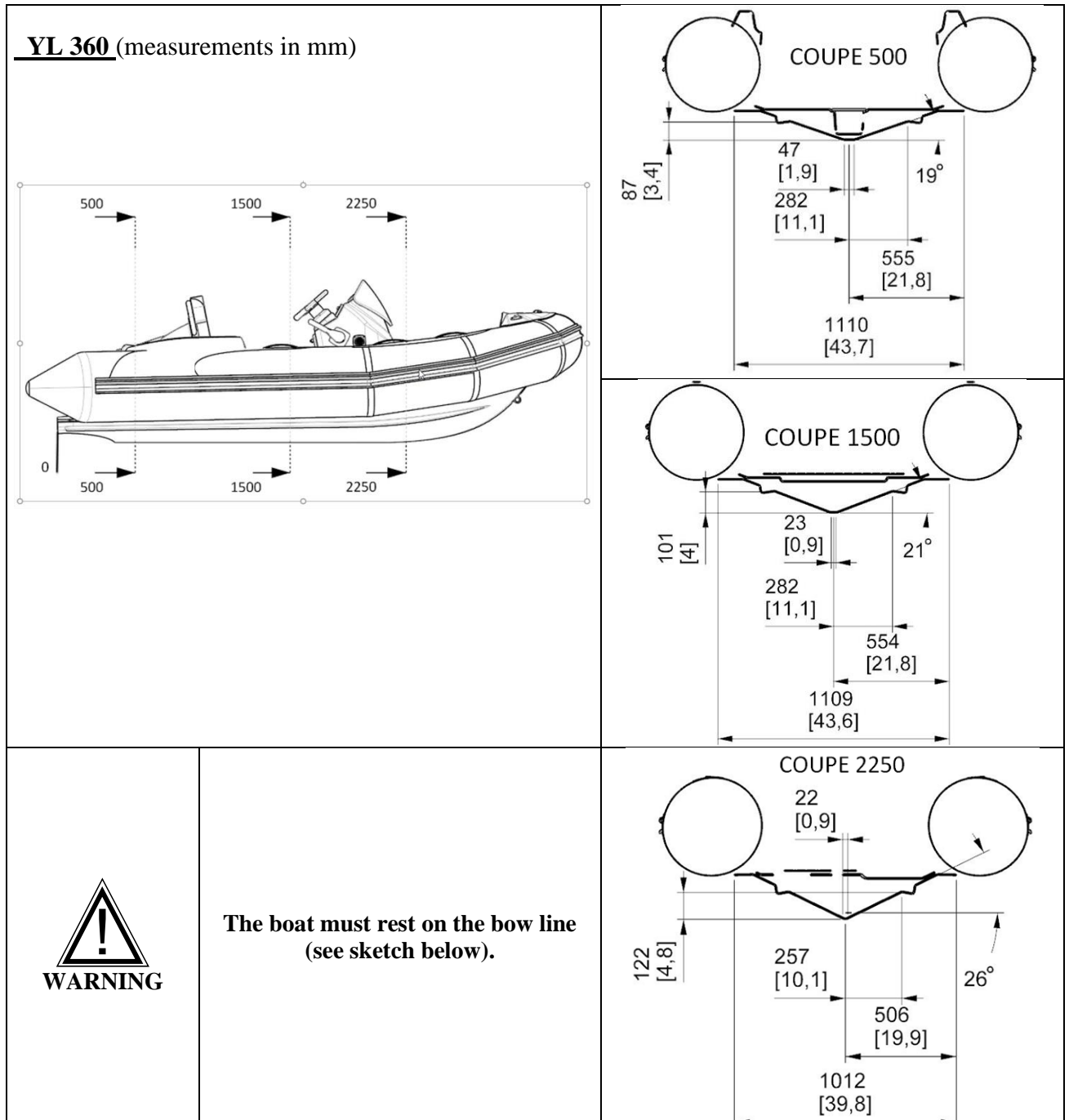

YL 400 (measurements in mm)

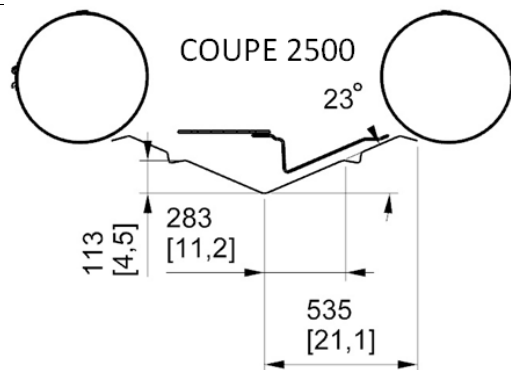
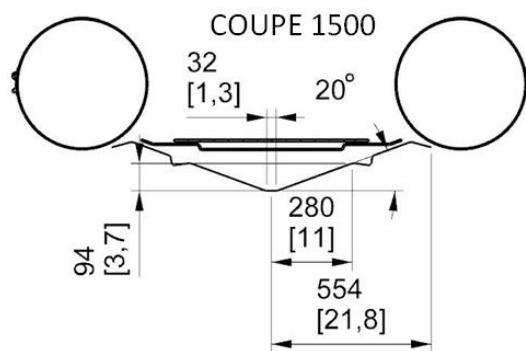
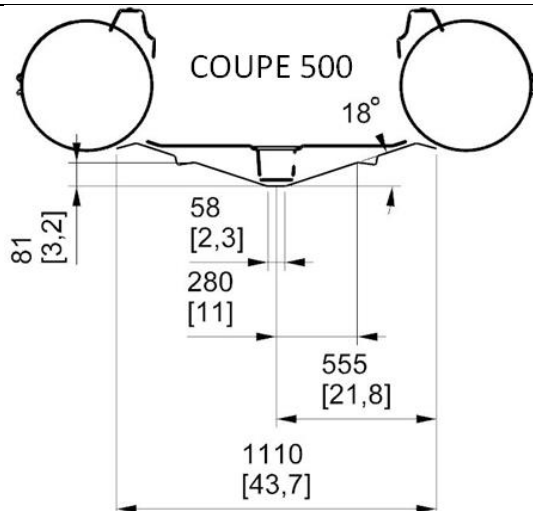
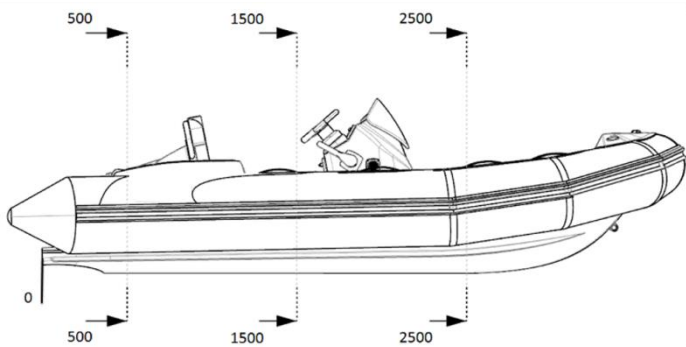

**The boat must rest on the bow line
(see sketch below).**

DESCRIPTION - HANDLING

I -4-3-Lifting:

 WARNING	<p>The lifting sling is available as an option; you must only use an AVON sling for lifting.</p>
---	--

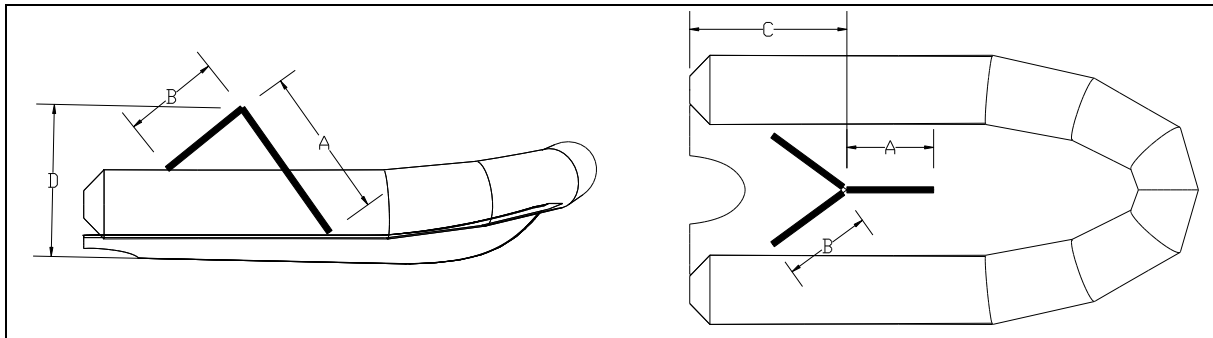

These values are an example		A	B	C	D
360 YL	(m)	1.25	1	1.45	1.4
	(ft)	4'1"	3'3"	4'8"	4'6"
400 YL	(m)	1.25	1	1.45	1.4
	(ft)	4'1"	3'3"	4'8"	4'6"

 WARNING	<p>No passengers on board while hoisting</p>
---	--

 CAUTION	<ul style="list-style-type: none"> All equipment must be unloaded from the boat for lifting or davit handling. The self bailer (item 20*) and the drain hole (item 22*) must be open to evacuate any rain water in the cockpit. <p style="margin-left: 20px;">* see chapter I-3 "Location of items"</p>
---	---

BUOYANCY TUBE – COMMISSIONING

II-1-FITTING THE BUOYANCY TUBE – MAIN STEPS

When assembling the boat, it is important that you follow the procedure in the correct order. Proceed step by step, checking the reference pages for procedure explanations.

PROCEDURE	PAGE	SECTION
1. inventory the parts of your boat and learn to recognize them	4-5	Inventory upon opening
	6-7	Location of items
2. fit the buoyancy tube on the hull	11	Installing the buoyancy tube
3. fit the internal protective flap	12	Fitting the protective flap
4. position the external protective flap		
5. place the valves in the inflation position	14	Inflation system
6. inflate the boat to the operating pressures	15	Inflating the boat
	16-17	Pressure
7. fit the external protective flap	12	Fitting the protective flap

BUOYANCY TUBE – COMMISSIONING

II-2 INSTALLING THE BUOYANCY TUBE ON THE HULL



IF THE BUOYANCY TUBE WAS STORED AT A TEMPERATURE BELOW 0°C / 32°F, LEAVE IT AT 20°C / 68°F FOR 12 HOURS BEFORE UNFOLDING.

NOTE

The buoyancy tube is fitted to the hull with the buoyancy tube **deflated**.

1

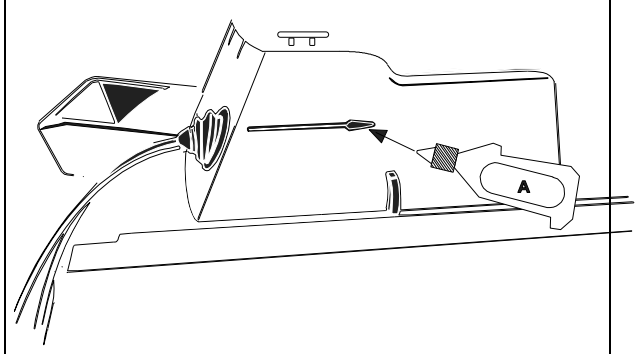
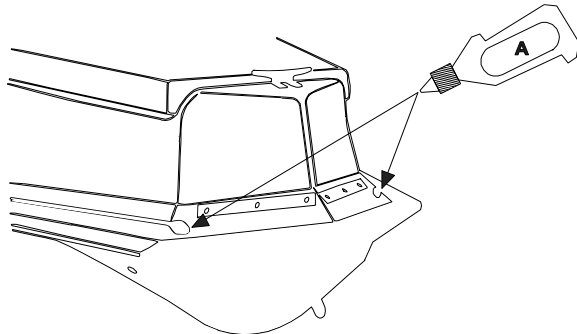

To facilitate the positioning of the buoyancy tube, apply liquid soap (A) to the hull rails.

2

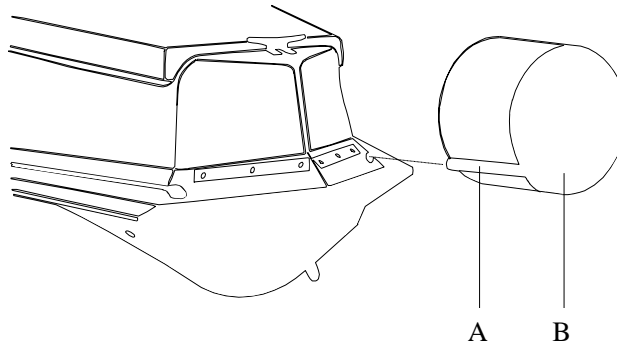

Position the buoyancy tube's (b) bolt rope (a) on the hull's rail.

3

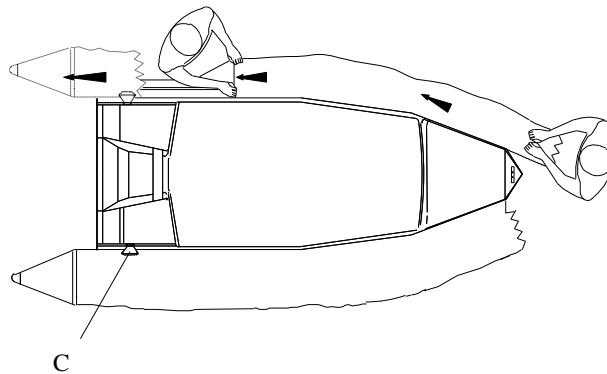

- Pull the buoyancy tube towards the boats stern (Do not forget to guide the upper bolt rope C).
- Repeat for the other side of the buoyancy tube

BUOYANCY TUBE – COMMISSIONING

4

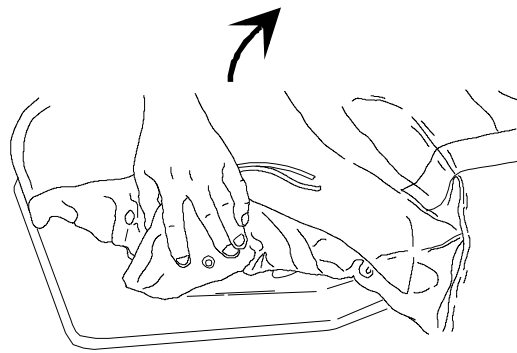

Install the internal rubber guard

5

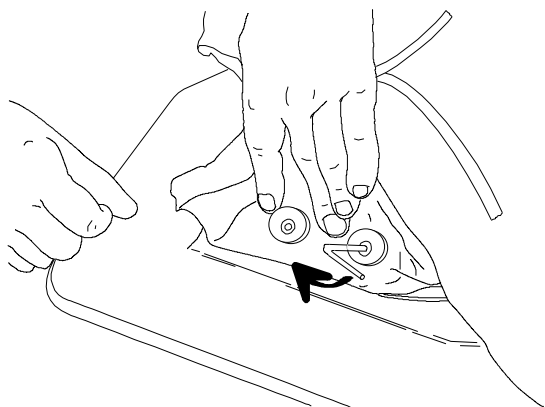

6

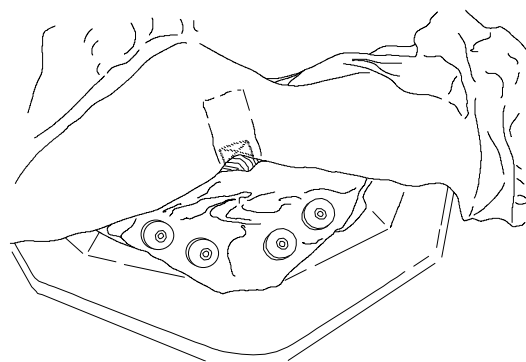

Fix the internal protective flap

7

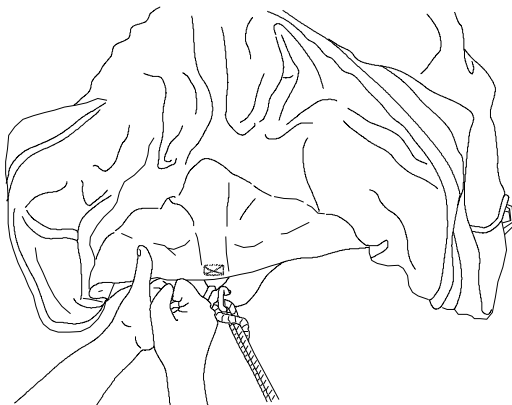

After fixing the internal protective flap on the hull, pull the buoyancy tube gently towards the forward section in order to send the external protective flap over the forward nose (do not attach it at this point). Then pull the buoyancy tube towards the aft end.

<p>NOTE</p>	<p>The external protective flap should be fixed after the buoyancy tube has been inflated</p>
--------------------	--

THEN BEGIN INFLATION

BUOYANCY TUBE – INFLATION SYSTEM

II -3-INFLATION SYSTEM

INFLATOR

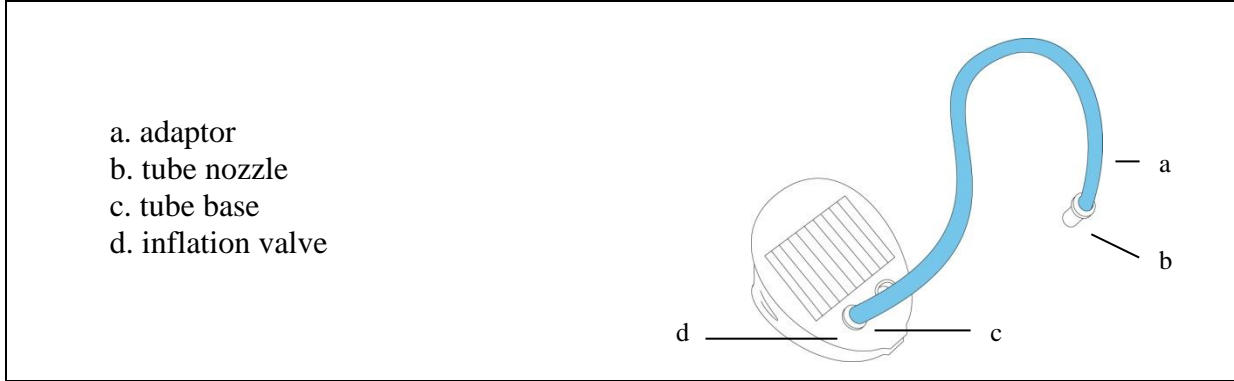

"EASY - PUSH" VALVES

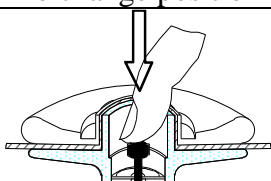
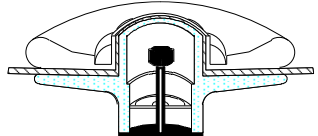
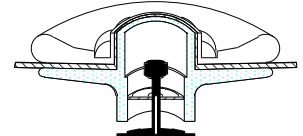
To change position	in inflating position	in deflating position
 Push	 The membrane is closed, the plunger is up	 The membrane is open, the plunger is down

BUOYANCY TUBE – PRESSURE

INFLATING THE ENGINE

Place all the valves in the inflation position.

Attach the hose connector to the inflation pump inflation port.
 To inflate your boat properly, the inflation pump should be correctly placed on the ground.
 The boat inflates rapidly if the inflation pump is used smoothly and without haste.

 WARNING	<p>Do not use a compressor or compressed air cylinder.</p>
---	---

BUOYANCY TUBE - PRESSURE

INFLATING THE BUOYANCY TUBE

- Place the adapter corresponding to the diameter of the semi-built in valve at the inflation pump hose nozzle.
- Inflate the buoyancy tube, **balancing the pressure between the different compartments until the partitions (a) are no longer visible (pressure = 240 mb)**

	<p>Never put a compartment under pressure while the others are still fully deflated.</p>	
--	--	--

	1	
--	---	--

	2	
--	---	--

Inflation is completed: Screw on the inflation valve plugs.

NOTE:	<p>A slight loss of air is normal before the cap is screwed on. Only the plugs provide final airtightness.</p>
--------------	--

BUOYANCY TUBE - PRESSURE

CORRECT PRESSURE

The correct pressure for the buoyancy tube is 240 mb/ 3.4 PSI.

The ambient temperature of the air or the water proportionally influences the internal pressure of the buoyancy tube:	Ambient temperature	Pressure inside the buoyancy tube
	+ 1°C	+ 4 mb / + 0.06 PSI
	- 1°C	- 4 mb / - 0.06 PSI

Thus it is important to anticipate:
Check and adjust the pressure of inflatable compartments (by inflating or deflating) depending on the temperature (particularly when temperature variations are high)

between the morning and evening in hot regions) and check that the pressure does not leave the recommended pressure zone (from 220 to 270 mb / green zone).

LOW PRESSURE RISK:

Example: Your boat is exposed to direct sunlight on the beach (temperature=50°C) at the recommended pressure (240 mb/3.4 PSI). When you launch the boat (temperature = 20°C), the temperature and pressure in the inflatable compartments will jointly drop (up to 120 mb) and **you must then re-inflate** them until the millibars lost due to the difference between air and water temperature are regained. It is normal to observe a drop in pressure at the end of the day when the outdoor temperature drops.

RISK OF OVERPRESSURE:

EXAMPLE: Your boat is inflated to its recommended pressure (240 mb/3.4 PSI) at the beginning or end of the day (low outside temperature = 10°C). Later in the day, your boat is left in the sun on the beach or on the deck of a boat (temperature = 50°C). The temperature inside the inflatable compartments may rise to 70°C (particularly for dark buoyancy tubes), doubling the initial pressure (480 mb). **You must then deflate** the boat to return to the recommended pressure.



If your boat is overinflated, the pressure will abnormally wear the inflatable structure which may lead to a breach of the assembly.

BUOYANCY TUBE - PRESSURE

IN THE EVENT OF OVERPRESSURE

EASY-PUSH VALVE:
Release air by pressing the valve plunger

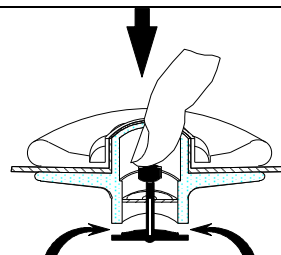

PROPULSION SYSTEM

III - Propulsion system

Comply with Zodiac's recommendations and with the engine manufacturer's recommendations.

For optimal use of your boat, please consult your dealer.

INSTALLATION AND CIRCUIT - FUEL

IV-1-Fuel installation

IV-1-1-Fuel tank

The tank is located under the steering console:

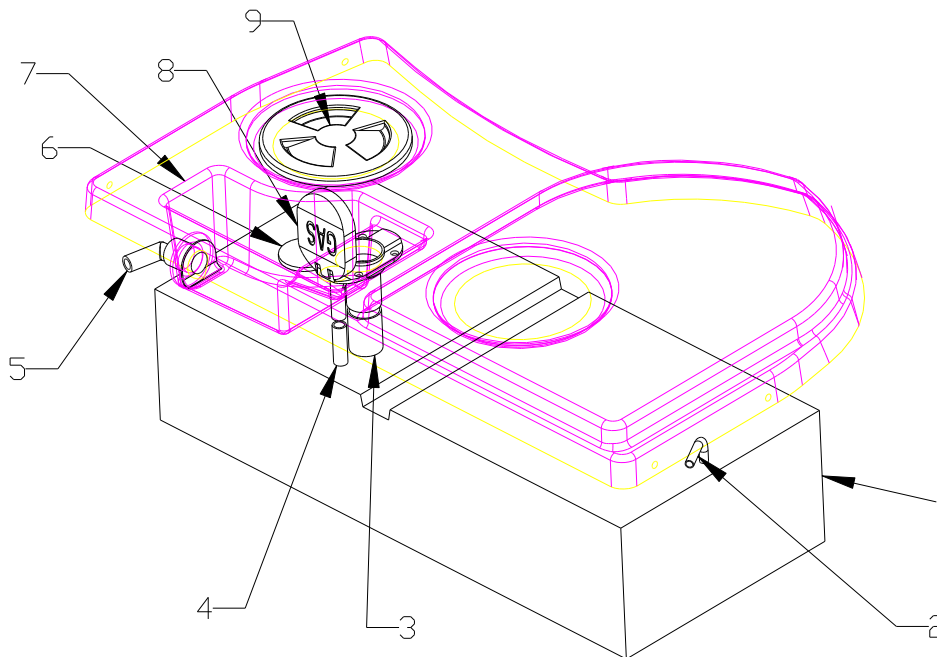

REF.	DESCRIPTION
1	Tank
2	Outlet for fuel supply to the engine
3	Filling hole
4	Vent
5	Overflow compartment drain hole
6	Gauge transmitter
7	"Overflow" compartment
8	Filler cap with integrated vent
9	Tank maintenance hatch

 WARNING	<p>It is vital to have a gauge dial. It is supplied with the engine. If your boat does not have one, contact your dealer.</p>
---	--

The probe supplied is to American standard:

Impedance (tank empty position) 30 Ohms

Impedance (tank full position) 240 Ohms

All the dials on the market are compatible, with a few very rare exceptions

To connect it, refer to the electrical diagram page 22.

INSTALLATION AND CIRCUIT – TANK AND ACCESSORIES

IV-1-2-Fuel/water separator filter

NOTE:	In order to protect the engine, a water / fuel separating filter is placed on the engine’s fuel supply system.
--------------	---

The water/fuel separator filter is located in the aft locker, on the starboard partition:

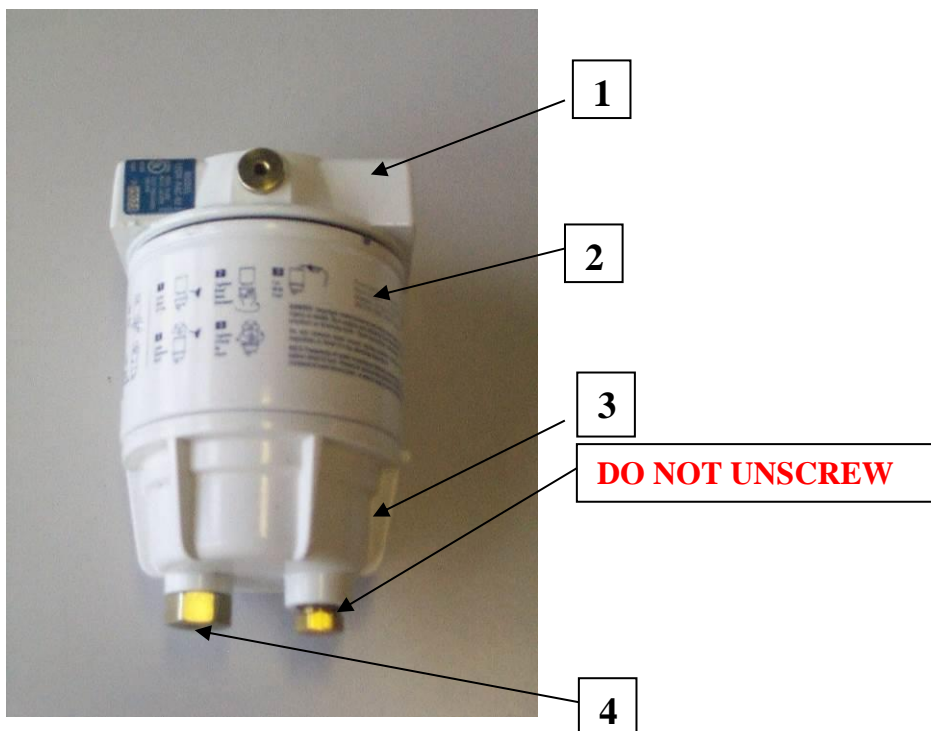

REF.	DESCRIPTION
1	Filter head, secured to boat
2	Replaceable filter cartridge
3	Metal bowl
4	Purge screw

 WARNING	Doing so could damage the seal and compromise the tightness of the bowl
--------------------	--

NOTE	Make sure that there is no water in the metal bowl each time you use your boat: Slightly unscrew the drain plug (do not remove it completely); drain the water; screw the plug back in if only fuel remains in the bowl. Do this more often if your engine is not functioning correctly.
-------------	---

INSTALLATION AND CIRCUIT – TANK AND ACCESSORIES

 WARNING	<p>It is vital to drain and clean the filter regularly and to change the cartridge at least once a year. The metal bowl can be reused.</p>
---	---

Changing the filter cartridge:

Follow ZODIAC's recommendations and those of the filter manufacturer.

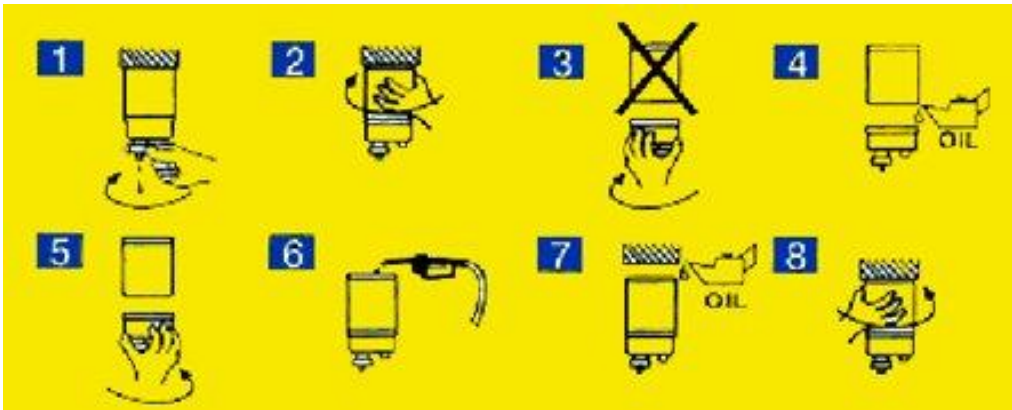

IV-1-3-Recommendations:

 WARNING	<ul style="list-style-type: none"> <input checked="" type="checkbox"/> ENSURING THAT THE FUEL TANK IS FULL BEFORE EACH OUTING PREVENTS CONDENSATION FROM FORMING. <input checked="" type="checkbox"/> HAVE THE TANK CLEANED EVERY 5 YEARS. <input checked="" type="checkbox"/> Check that all hose clamps are tight. <input checked="" type="checkbox"/> When you drain the filter, do not empty the water into the boat. Place a recovery tray under the filter. <input checked="" type="checkbox"/> SHUT OFF THE POWER SUPPLY BEFORE REMOVING THE FILTER CARTRIDGE. <input checked="" type="checkbox"/> Carefully read the information provided in the filter's instruction manual.
---	---

 WARNING	<ul style="list-style-type: none"> <input checked="" type="checkbox"/> Petrol is extremely flammable. Make sure that the engines are turned off before working on the fuel system. Do not smoke; keep all flames or incandescent material well away from the work area.
---	---

INSTALLATION AND CIRCUIT - ELECTRICITY

IV -2-ELECTRICAL DIAGRAM

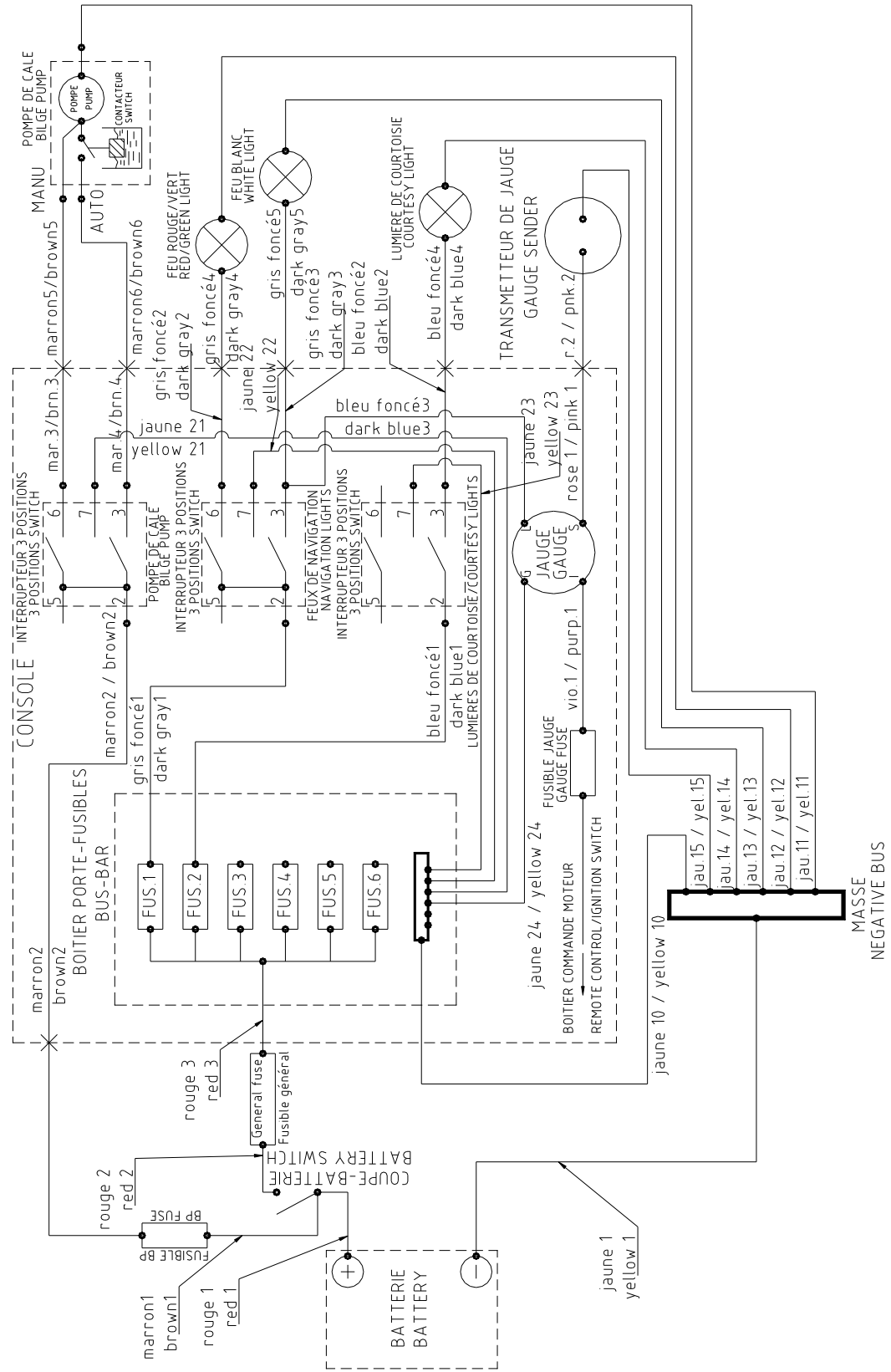



INSTALLATION AND CIRCUIT – CONNECTION of options

IV -3-BATTERY (not supplied)

Comply with Zodiac's recommendations and with the recommendations of the battery manufacturer for standard maintenance.

	<p>Maintain your battery:</p> <ul style="list-style-type: none"> <input checked="" type="checkbox"/> KEEP THE BATTERY CLEAN AND DRY IN ORDER TO AVOID PREMATURE WEAR. <input checked="" type="checkbox"/> Tighten and maintain the terminal lugs by greasing them regularly.
---	---

 WARNING	<p>The water from the water supply system contains mineral which damages batteries. You should thus always top up with distilled water.</p>
 WARNING	<ul style="list-style-type: none"> • Keep the batteries and the electrolyte out of the reach of children • Always keep the battery upright, never on its side. • When adding electrolyte or when recharging the battery, always remove it from the engine compartment • Battery electrolyte is a toxic and dangerous liquid. It contains sulphuric acid which can cause serious burns. Avoid contact with skin, eyes and clothes. • Batteries can emit explosive gases. Keep them away from sparks, open flames, cigarettes, etc. • When charging or using a battery, work in a well-ventilated environment. Always protect your eyes when working close to a battery.

NOTE:	<ul style="list-style-type: none"> <input checked="" type="checkbox"/> IF YOU DO NOT PLAN TO USE YOUR ZODIAC® FOR A MONTH OR MORE, REMOVE THE BATTERY AND STORE IT IN A COOL, DARK AND DRY PLACE. Fully recharge the battery before reusing it. <input checked="" type="checkbox"/> IF THE BATTERY IS BEING STORED FOR A LONGER PERIOD, CHECK ELECTROLYTE DENSITY AT LEAST ONCE A MONTH AND RECHARGE THE BATTERY AS SOON AS THE DENSITY IS TOO LOW. <p>Electrolyte density: 1.28 at 20°C</p>
--------------	--

NOTE:	<p>When you stop using the boat, set the circuit-breaker to OFF.</p>
--------------	--

INSTALLATION AND CIRCUIT – CONNECTION of options

IV-4-STORAGE OF NAVIGATION LIGHT MAST



 <p>WARNING</p>	<p>To not damage the navigation light mast when closing the seat, always stow it as shown on the photo above.</p>
---	---

<p>NOTE</p>	<p>To facilitate fitting the mast in the fittings, you may use soapy water.</p>
--------------------	---

VIEW FROM ABOVE:

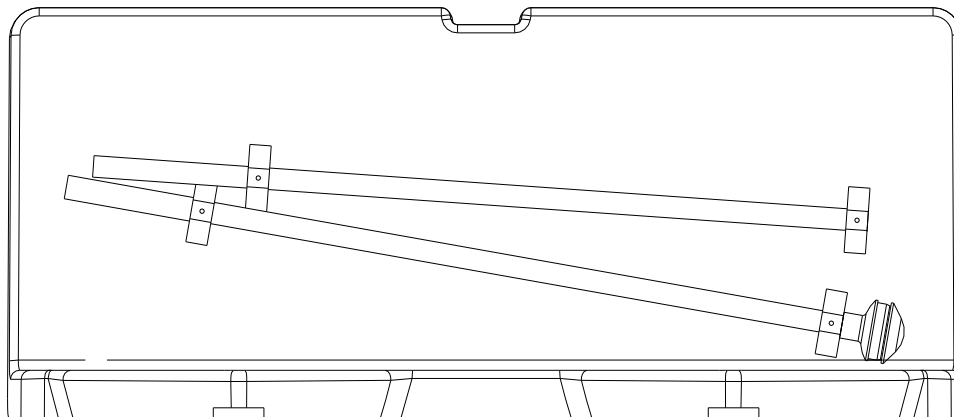

INSTALLATION AND CIRCUIT – CONNECTION of options

IV -5-CONNECTION OF OPTIONS

IV-5-1-Precautions:

The boat is provided as standard with a bilge pump, navigation lights and a deck light. However, 4 locations remain available on the fuse box (under the console) for the connecting of additional accessories under certain conditions:

- ① The accessories you want to add must be connected to the console.
- ② Accessories are divided into two categories:
 - A** → Accessories that are used or which may be used continuously during normal use of the boat,
 - B** → Accessories that are used intermittently.

A	and	B	
Bilge fan		Cigarette lighter connector	
Radio		Miscellaneous lighting	
Depth sounder		Horn	
GPS		Miscellaneous electronic equipment	
Searchlight		Shower pump	
Alarm system		Max. power	72 W max.
Refrigerator			
VHF			
Σ			180 W max.

 WARNING	<p>You must make sure that the total power of the accessories you add in column A is 180 W (15 A) or less AND that the max power of an accessory in column B is 72 W (6 A) or less.</p> <p>The cross-sections of the different cables in the wiring circuit were calculated using these figures; not following this rule may lead to electrical faults and cause short circuits.</p>
---	--

NOTE:	<p>If you are getting several pieces of electrical equipment installed. The total immediate consumption could potentially exceed your outboard motor's capacity. For example, the electrical wiring harness can accept instant consumption of 285W (including navigation lights and bilge pump), which is a little less than a 24 A output current. The alternators in the current engines generally provide 15 A when at full throttle (Check your engine's technical documentation). You should therefore avoid using this equipment over a long period of time, as you run the risk of draining the battery and not being able to restart the engine.</p>
--------------	---

INSTALLATION AND CIRCUIT – CONNECTION of options

Example 1

You want to add:
 A 72 W VHF,
 A 36 W GPS,
 A 60 W radio,
 A 72 W cigar lighter,
 A 20 W clock.

A	
Bilge fan	
Radio	60 W
Depth sounder	
GPS	36 W
Searchlight	
Alarm system	
Refrigerator	
VHF	72 W
Σ	168 W (<180 W) ☺

and

B	
Miscellaneous lighting	
Miscellaneous electronic equipment	20 W (clock)
Shower pump	
Max. power	20 W (< 72 W) ☺

CONCLUSION	
------------	---

Example 2

You want to add:
 A 60 W VHF,
 A 36 W GPS,
 A 48 W radio,
 A 120 W searchlight.

A	
Bilge fan	
Radio	48 W
Depth sounder	
GPS	36 W
Searchlight	120 W
Alarm system	
Refrigerator	
VHF	60 W
Σ	264 W (> 180 W) ☹

and

B	
Miscellaneous lighting	
Miscellaneous electronic equipment	
Shower pump	
Max. power	0 (< 72 W) ☺

CONCLUSION	
------------	---

INSTALLATION AND CIRCUIT – CONNECTION of options

Example 3

You want to add:

- A 60 W GPS,
- A 60 W radio,
- A 120 W horn.

A	
Bilge fan	
Radio	60 W
Depth sounder	
GPS	60 W
Searchlight	
Alarm system	
Refrigerator	
VHF	
Σ	120 W (< 180 W) ↻

and

B	
Miscellaneous lighting	
Miscellaneous electronic equipment	120 W
Shower pump	
Max. power	120 W (> 72 W) ⚡

CONCLUSION	
------------	--

NOTE	Some manufacturers will indicate the amperage rather than the absorbed power. With direct current from a 12 V battery, as is the case here, simply multiply by 12 to obtain the power.
-------------	---

IV -5-2-Wiring:

- ① Choose a free fuse location.
- ② Connect the power supply of your accessory to the terminal corresponding to this slot using a 6mm female tab type terminal lug.
- ③ If you have to add cable for the connection, use cable with a cross-section of at least 1.5mm² that complies with "marine" standards (UL1426 or SAE J378 or SAE J1127 or SAE J1128 or more generally meeting ABYC and/or EC standards),
- ④ Connect the earth cable of your accessory to the ground terminal strip using a Ø5 "ring terminal" (same comment as for the cable above),
- ⑤ Insert an ATO type fuse with a max current of 15A and greater than the load current of your device.

IV -5-3-Connecting the petrol gauge:

Connect as shown in the diagram (page 19).

INSTALLATION AND CIRCUIT – CONNECTION of options

IV -5-4-Connecting accessories on the console:

Depending on the level of equipment of your tender, Zodiac recommends placing it in the following manner (see templates supplied with the boats) which optimises the space available.

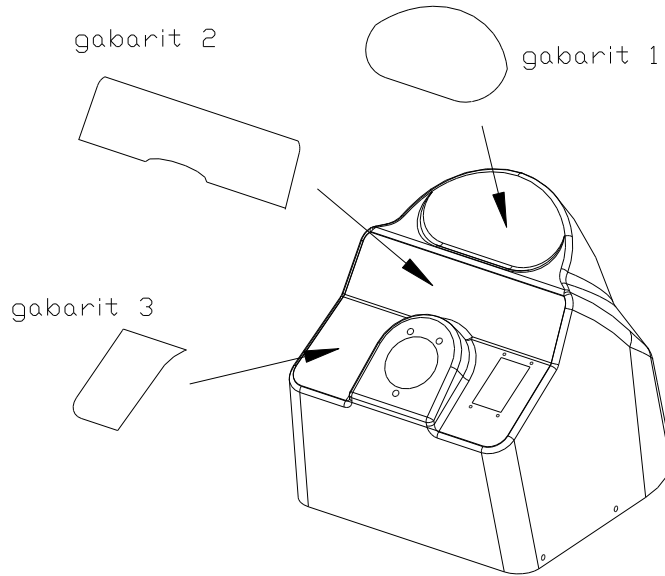

IV -6-BILGE PUMP OPERATION

The bilge pump is not wired to the battery switch and operates independently; the control switch  is always ON.

- ① Automatic operation (set position): in this position, the bilge pump operates automatically. The indicator light is on.
- ② Off: in this position (set position), the bilge pump is off. The indicator light is off.
- ③ Forced operation: the switch has to be held depressed to operate it. As soon as you release the switch, it returns to the Stop position (2).

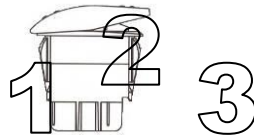
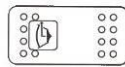

 WARNING	<p>At anchor, set the bilge pump switch to the automatic position.</p>
---	---

NOTE	<p>Zodiac recommends the use of a tarpaulin or mooring cover in order to prevent water ingress in the event of rain.</p>
-------------	---



WARNING

Your attention is drawn to the finishing process in which structural components such as steering consoles, seats and superstructure elements are installed by parties other than the manufacturer. These elements should be installed in compliance with the relevant requirements of ISO 6185-3 to ensure that all such installations do not invalidate the initial assessment.

Also ensure that the subsequent installation of consoles and other structural elements not initially supplied with the boat is performed in accordance with the installation recommendations provided by the manufacturer and ZODIAC's recommendations.



Z NAUTIC GROUP
2 chemin de la Val Priout
31450 AYGUESVIVES
FRANCE

YACHTLINE 360 - 400

© Copyright Z NAUTIC - Z NAUTIC S.A.S.U. with capital of 7,095,000.00 Euros- Toulouse Trade Register 812 206 340

**E
N
G
I
N
E
E
R
I
N
G**



Tomo 2

***YACHTLINE
360 / 400***

611133 A



LEA DETENIDAMENTE ESTE MANUAL ANTES DE LA PUESTA EN SERVICIO DE SU ZODIAC.

TOMO 2

DESCRIPCIÓN - FLOTADOR

SISTEMA DE PROPULSIÓN

INSTALACIÓN Y CIRCUITOS





ÍNDICE

	PÁGINA
⇒ I - DESCRIPCIONES GENERALES	A
I-1- Características técnicas -----	2 - 3
I-2- Inventario -----	4 - 5
I-3- Ubicación de los elementos -----	6 - 7
I-4- Manipulación -----	8 - 10
⇒ II - FLOTADOR	
II-1- Pasos importantes de la puesta en servicio del flotador -----	11



II-2- Montaje del flotador en el casco -----	12 - 13
II-3- Sistema de inflado -----	14
II-4- Presión -----	14 - 16
⇒ III - SISTEMA DE PROPULSIÓN	17
⇒ IV - INSTALACIÓN Y CIRCUITOS	
IV-1- Instalación de combustible -----	18 - 20
IV-2- Esquema eléctrico -----	21
IV-3- Batería -----	22
IV-4- Almacenamiento del mástil de luz de navegación -----	23
IV-5- Conexión de opciones -----	24 - 26
IV-6- Funcionamiento de la bomba de achique -----	27



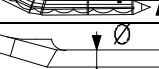

DESCRIPCIÓN - CARACTERÍSTICAS TÉCNICAS

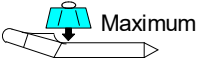

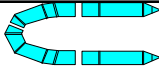
I-1-CARACTERÍSTICAS TÉCNICAS

Dimensiones			
		YL 360	YL 400
	(m)	3,60	4,00
	(ft)	11' 8"	13' 1"
	(m)	2	2,40
	(ft)	6' 7"	7' 10"
	(m)	1,77	1,77
	(ft)	5' 10"	5' 10"
	(m)	0,86	0,86
	(ft)	2' 10"	2' 10"
	(m)	0,455	0,455
	(ft)	1' 6"	1' 6"

Certificación	
 (Directiva 94/25/CE)	C

Capacidad			
		YL 360	YL 400
 (ISO)		4	5
 Maximum	kg ⁽¹⁾	605	735
	lb ⁽¹⁾	1.334	1.621
 Maximum	kg ⁽²⁾	200	218
	lb ⁽²⁾	441	481
 Compartimento		3	3

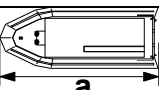
Motorización			
		YL 360	YL 400
 Long			
	Potencia MÍNIMA recomendada	CV ⁽³⁾	15
		kW ⁽³⁾	12
	Potencia MÁXIMA recomendada	CV	40
		kW	30
	Potencia MÁXIMA autorizada	CV ⁽³⁾	40
		kW ⁽³⁾	30
 Maximum	Peso MÁXIMO del motor	kg	119
		lb	262

Dimensiones			
		YL 360	YL 400
 a	a ⁽⁴⁾	3,18 m	3,58 m
		10' 5"	11' 9"
 b	b ⁽⁴⁾	1,40 m	1,40 m
		4' 6"	4' 6"
 c	c ⁽⁴⁾	0,98 m	0,98 m
		3' 2"	3' 2"

DESCRIPCIÓN - CARACTERÍSTICAS TÉCNICAS

NOTA	Tolerancias de las dimensiones: +/- 4 %
------	---

NOTA	<p>(1) La carga máxima autorizada se ha calculado según la norma ISO 6185. Se recomienda navegar con precaución cuando la embarcación esté cargada al máximo.</p> <p>(2) Pesos indicados sin accesorios</p> <p>(3) Las potencias recomendadas corresponden a una explotación óptima de las capacidades de la embarcación para una carga media (4 personas).</p> <p>(4) Dimensiones del casco sin flotador.</p> <p>Utilice la potencia máxima autorizada con suma prudencia (véase el Tomo 1 del manual, capítulo "Consejos de navegación").</p>
------	---

 ATENCIÓN	No sobrepase la carga máxima indicada en la placa del fabricante. La carga máxima incluye el peso del o de los motores, del combustible, de los accesorios, de los pasajeros y de su equipamiento, así como cualquier otro tipo de carga.
--	---

 ATENCIÓN	No almacene productos inflamables en el compartimento de popa. Está terminantemente prohibido almacenar un depósito suplementario.
---	--

SOLO EN EL 400DL:

 ADVERTENCIA	<p>Maniobrabilidad limitada a partir de 25 nudos.</p> <p>Riesgo de pérdida de control en caso de virajes cerrados.</p> <p>Reduzca la velocidad* antes de efectuar virajes en cualquier dirección.</p> <p>* También puede accionar el power trim e introducir el motor en el tablero de popa.</p>
--	--

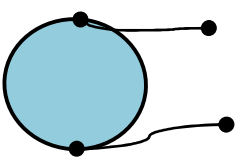
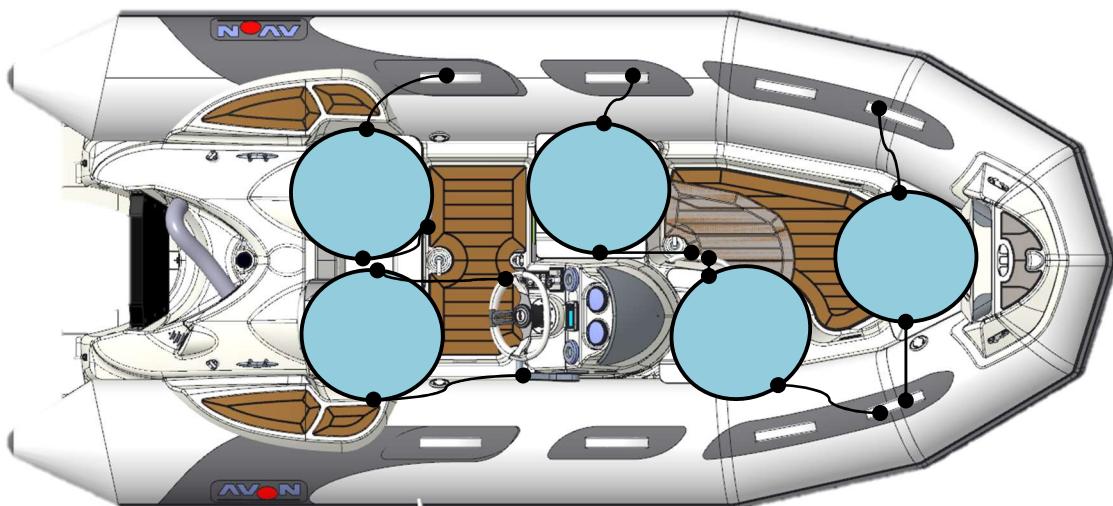

Asiento con asas de sujeción para el Yachtline 400

DESCRIPCIÓN - INVENTARIO

I-2-INVENTARIO

CASCO
• casco de poliéster
• cubierta contramoldeada antideslizante
• Tablero de popa unido y carena de "flaps"
• Consola con alojamiento
• 1 cáncamo de roda
• 1 pozo de fondeo + pañol de proa de consola (únicamente en 400 YL)
• 1 pañol de popa
• 4 asientos con tapicería en 360 YL (5 asientos en 400 YL)
• 2 cornamusas de amarre de popa
• 1 marchapié de poliéster de proa con cornamusa de amarre, luces de navegación y ledes
• 1 mástil de luz blanca plegable y desmontable
• 1 luz de cubierta
• 3 cáncamos articulados de izado
• 2 cáncamos de arrastre
• 2 achicadores + 1 espiche de casco

FLOTADOR
• Flotador extraíble
• Tejido Hypalon-Néoprène 1100 decitex
• Válvulas Easy-Push
• Cinta antidesgaste de perfil ancho
• 6 asideros
• Refuerzos de conos

CONSOLA
• Volante y mando de dirección a distancia
• 3 interruptores
• Guanteras

DESCRIPCIÓN - INVENTARIO

EQUIPAMIENTO ESTÁNDAR
• 1 depósito fijo (35 litros + transmisor de nivel de combustible + separador agua/gasolina) con respiradero y dispositivo antidesbordamiento
• Luces de navegación y luces de cubierta
• 1 bandeja batería
• 1 interruptor de batería
• Preinstalación eléctrica para añadir accesorios suplementarios
• 1 bomba de achique
• 2 pagayas
• 1 inflador de pie
• 1 maletín de reparación
• 1 manual del propietario (2 tomos)
• 1 tapón manómetro

ACCESORIOS OPCIONALES
• Kit de izado
• Escala de baño
• Respaldo trasero
• Cubierta de teca sintética
• Cortavientos

DESCRIPCIÓN – UBICACIÓN DE LOS ELEMENTOS

I-3-UBICACIÓN DE LOS ELEMENTOS

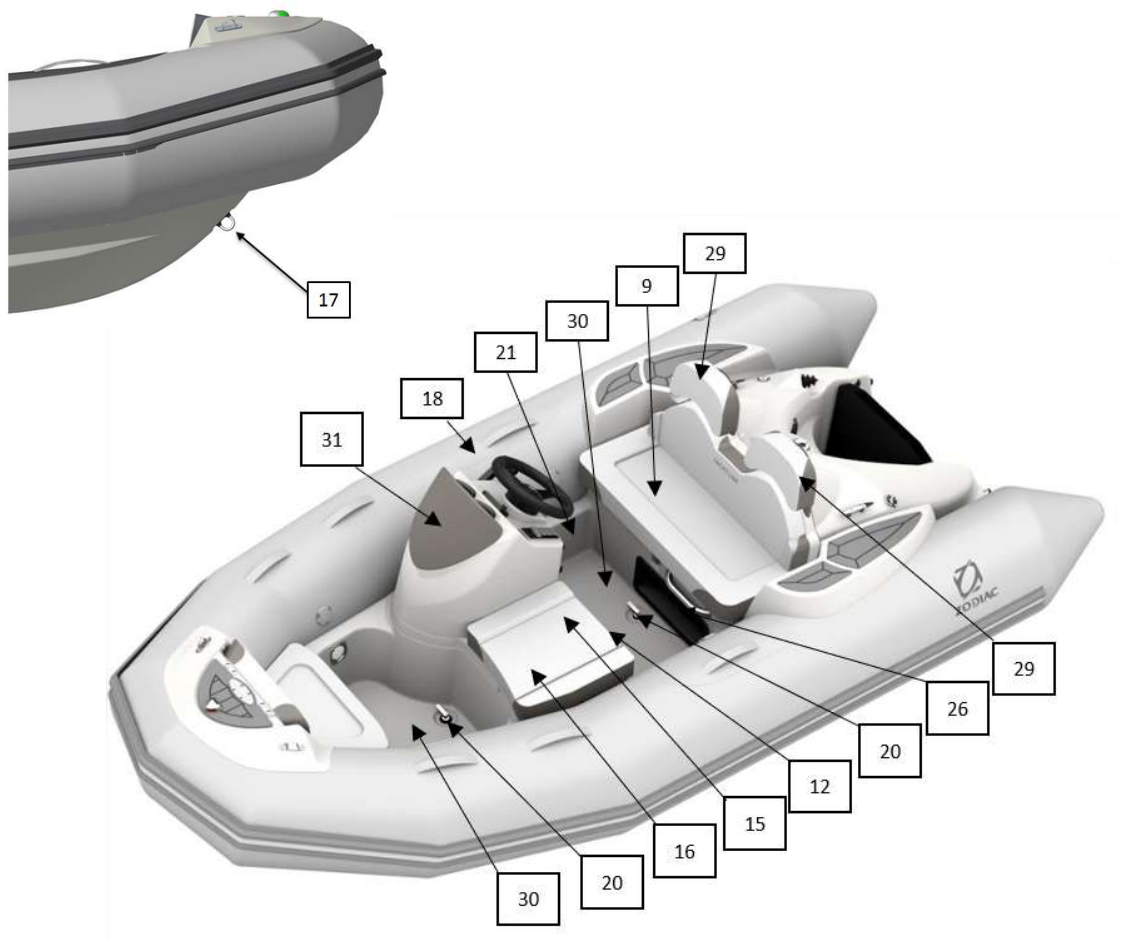
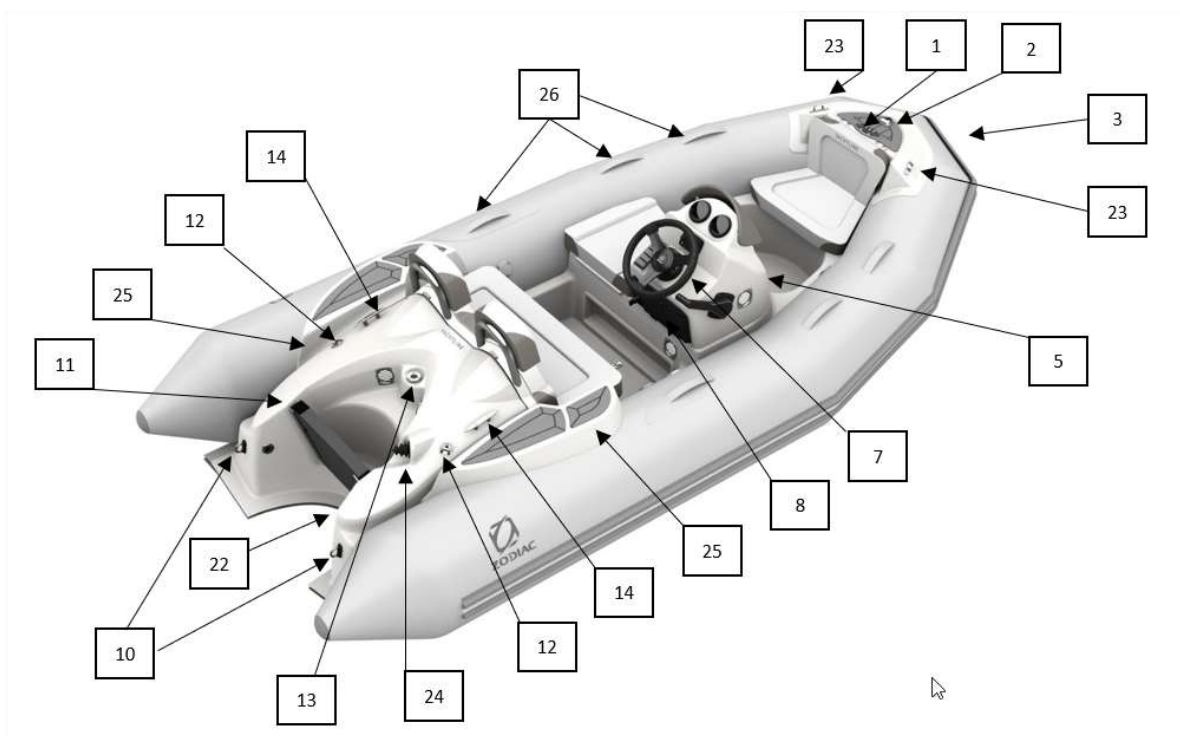

DESCRIPCIÓN – UBICACIÓN DE LOS ELEMENTOS

REFERENCIA	DESCRIPCIÓN
1	Cornamusa de amarre de proa
2	Luces de navegación
3	Marchapié de poliéster de proa
4	Pozo de fondeo
5	Consola
6	Interruptores
7	Volante
8	Guantera
9	Asiento de popa reclinable
10	Anillas de tracción/de estiba
11	Tablero de popa
12	Anillos de izado
13	Base de mástil de luz blanca
14	Cornamusas de amarre de popa
15	Sistema de llenado de depósito
16	Trampilla de acceso de mantenimiento del depósito
17	Cáncamo de roda
18	Flotador
19	Soporte extintor
20	Achicador
21	Luz de puente
22	Espiche
23	Pasacabos
24	Pasacables
25	Marchapié de poliéster
26	Asidero
27	Válvula Easy-Push
28	Toma de mechero de 12 V
29	Respaldo trasero
30	Cubierta de teca sintética
31	Cortavientos

DESCRIPCIÓN - MANIPULACIÓN

I-4-MANIPULACIÓN

I-4-1-Transporte:

- Los consejos sobre la puesta en remolque se especifican en el manual del propietario, TOMO I.

I-4-2-Almacenamiento:

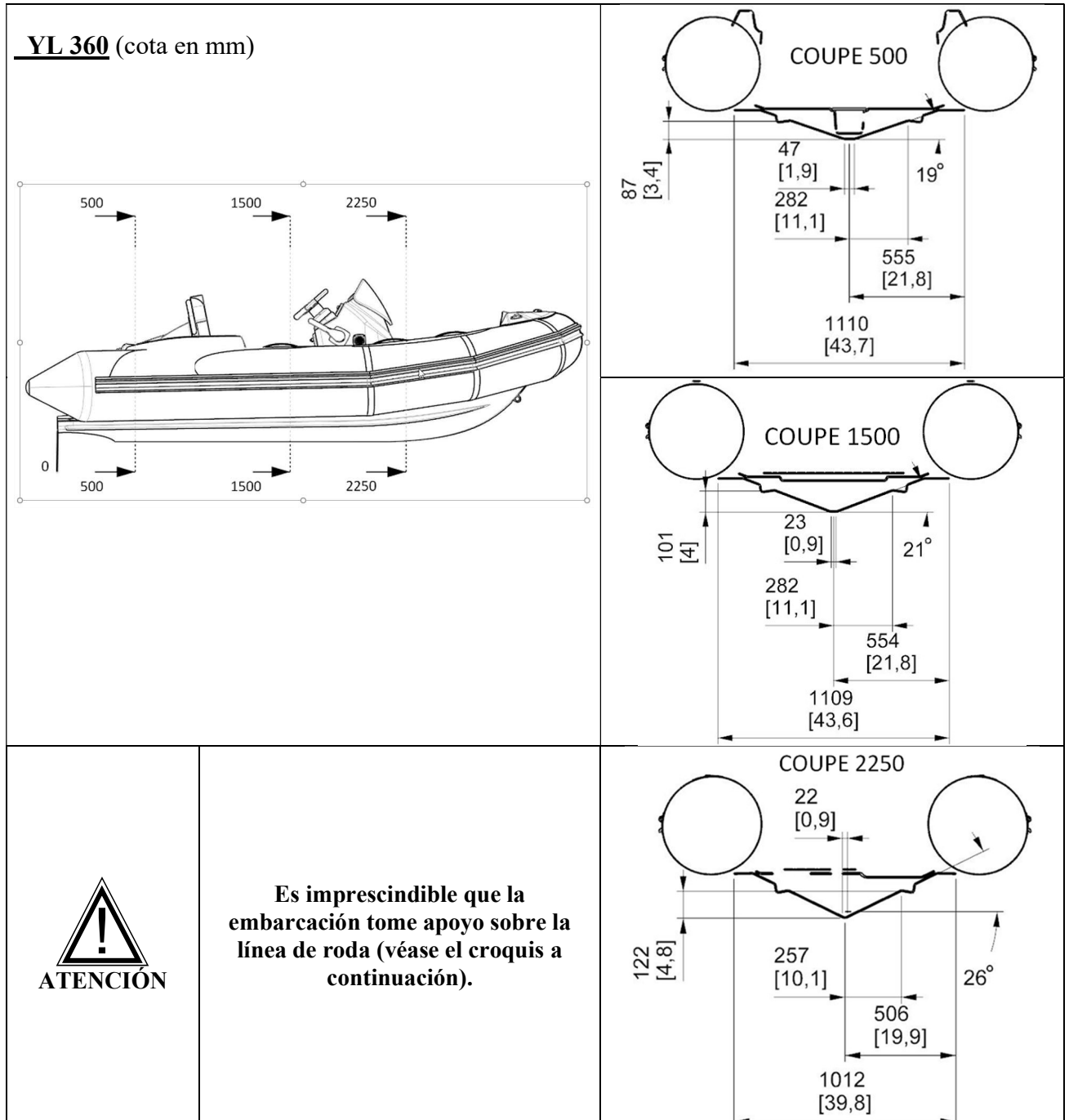

YL 400 (cota en mm)

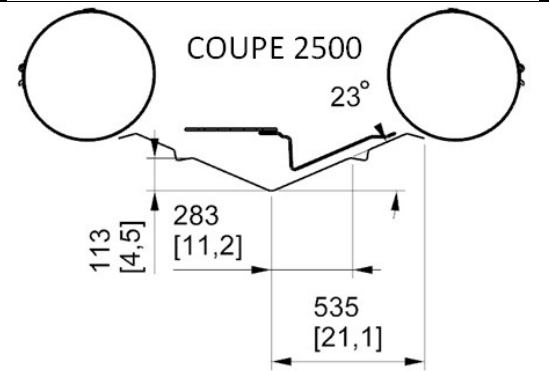
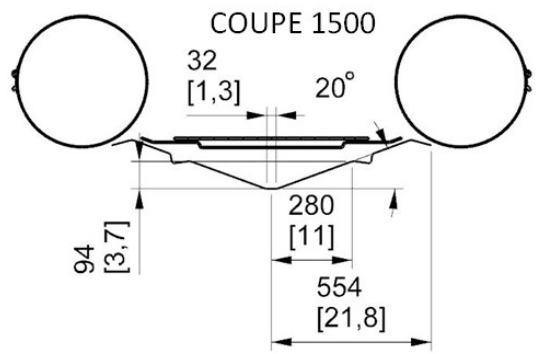
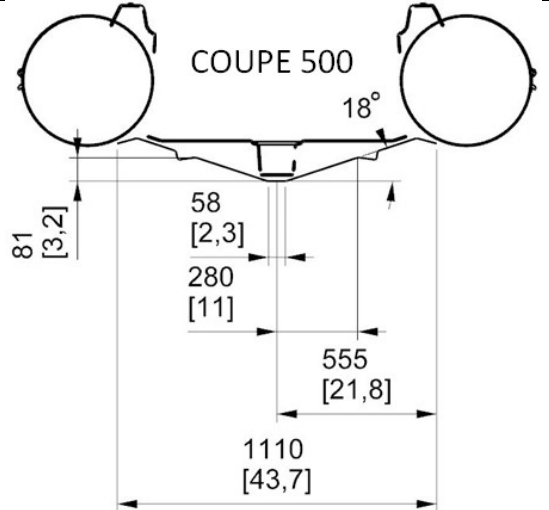
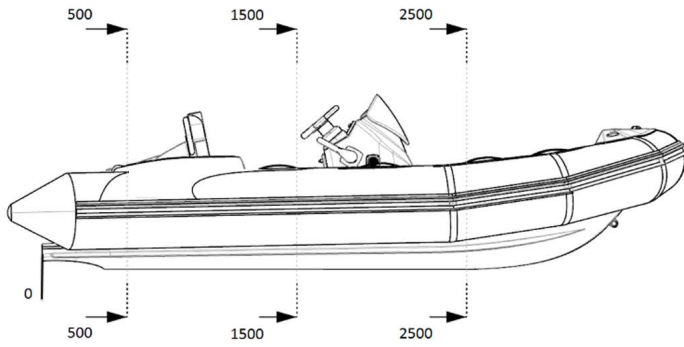

Es imprescindible que la embarcación tome apoyo sobre la línea de roda (véase el croquis a continuación).

DESCRIPCIÓN - MANIPULACIÓN

I-4-3-Izado:

 ADVERTENCIA	<p>La eslinga de izado está disponible como accesorio; debe utilizar exclusivamente una eslinga AVON para el izado.</p>
---	---

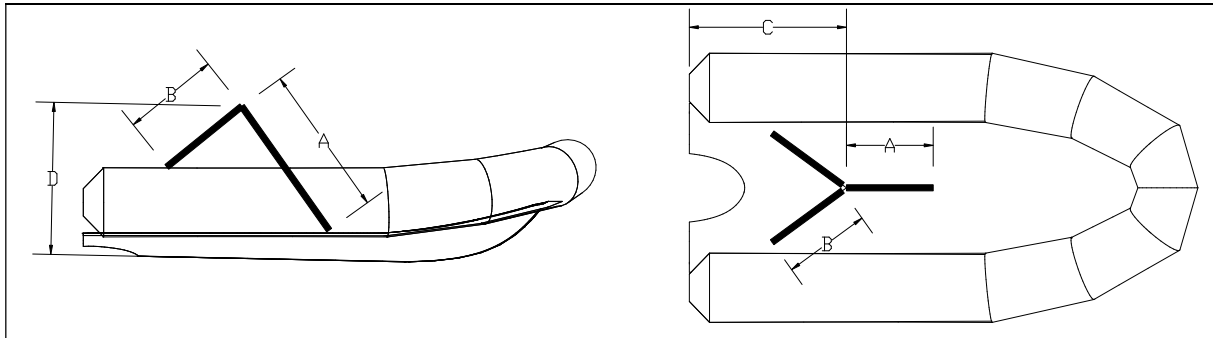

Estos valores se dan a título indicativo.		A	B	C	D
360 YL	(m)	1,25	1	1,45	1,4
	(ft)	4' 1"	3' 3"	4' 8"	4' 6"
400 YL	(m)	1,25	1	1,45	1,4
	(ft)	4' 1"	3' 3"	4' 8"	4' 6"

 ADVERTENCIA	<p>No debe haber nadie a bordo durante el izado con grúa</p>
---	--

 ATENCIÓN	<ul style="list-style-type: none"> La embarcación debe estar descargada de cualquier material durante el izado con grúa o la colocación de pescantes. Los achicadores de cubierta (ref. 20*) y el espiche (ref. 22*) deben estar abiertos para garantizar la evacuación eventual de agua de lluvia en el cockpit. <p style="margin-left: 20px;">* Véase el capítulo I-3 "Ubicación de los elementos".</p>
--	---

FLOTADOR – PUESTA EN SERVICIO

II-1-PASOS IMPORTANTES DE LA PUESTA EN SERVICIO DEL FLOTADOR

El proceso de montaje de la embarcación sigue un orden que le rogamos respete. Proceda etapa por etapa consultando para cada una las páginas indicadas con las explicaciones del procedimiento.

PROCEDIMIENTO	PÁGINA	SECCIÓN
1. haga el inventario de los elementos que componen su embarcación y aprenda a reconocerlos	4-5	Inventario al desembalar
	6-7	Ubicación de los elementos
2. monte el flotador en el casco	11	Montaje del flotador
3. fije la faldilla interior. 4. coloque la faldilla exterior	12	Fijación de la faldilla
5. active las válvulas en posición de inflado	14	Sistema de inflado
6. infle la embarcación con las presiones de utilización	15	Inflado de la embarcación
	16-17	Presión
7. fije la faldilla exterior	12	Fijación de la faldilla

FLOTADOR – PUESTA EN SERVICIO

II -2-MONTAJE DEL FLOTADOR EN EL CASCO



SI EL FLOTADOR HA SIDO ALMACENADO A UNA TEMPERATURA INFERIOR A 0 °C, DÉJELO 12 HORAS EN UN LUGAR TEMPLADO (20 °C) ANTES DE DESPLEGARLO.

NOTA

El montaje del flotador en el casco se realiza con el flotador **desinflado**.

1

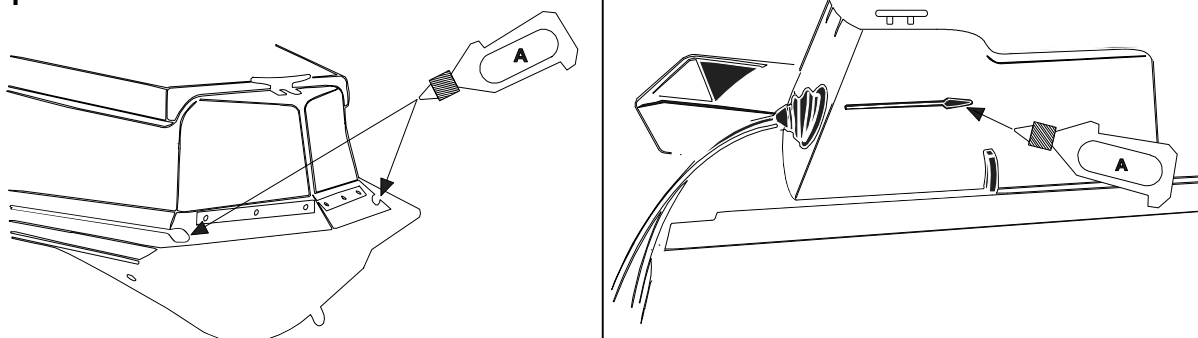

Para facilitar la colocación del flotador, aplique jabón líquido (A) en los rieles del casco

2

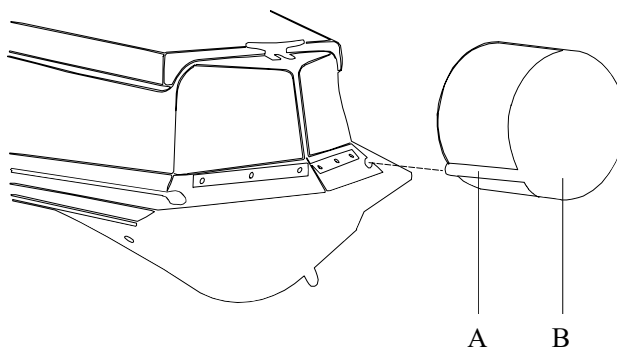

Coloque la relinga (a) del flotador (b) en el riel del casco

3

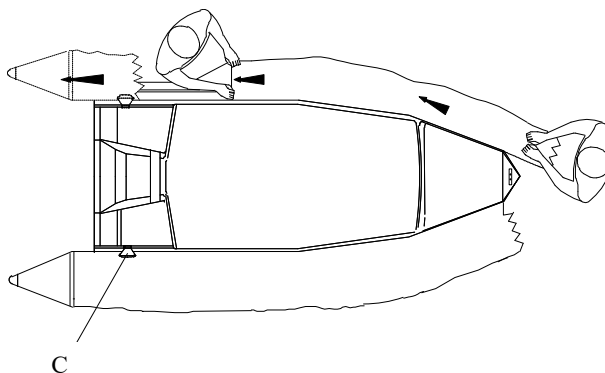

- Tire del flotador hacia atrás de la embarcación (no olvide guiar la relinga superior C).
- Proceda de la misma manera para el otro lado del flotador.

FLOTADOR - PUESTA EN SERVICIO

4

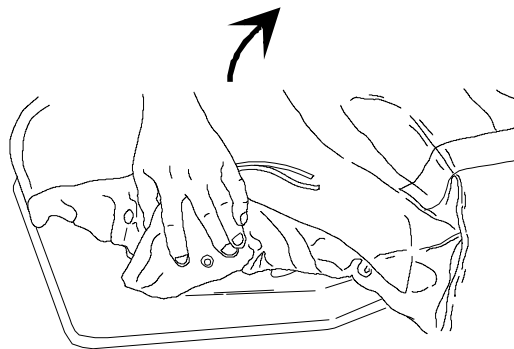

Posicione la faldilla interna

5

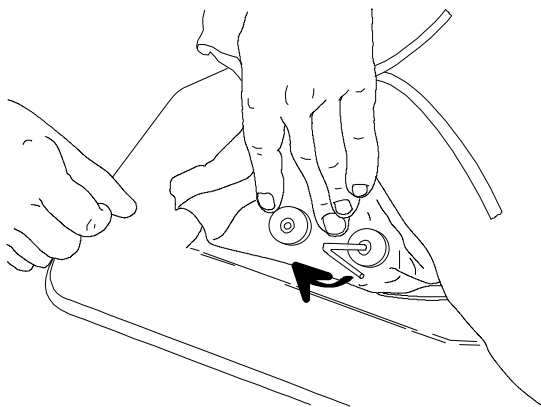

6

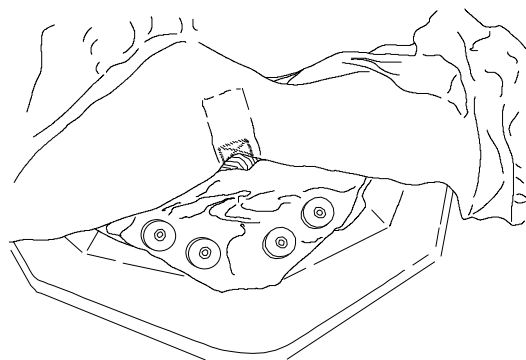

Fije la faldilla interna

7

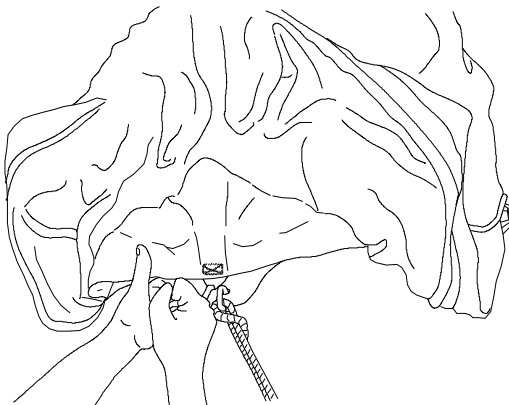

Después de haber fijado la faldilla interna sobre el casco, tire ligeramente del flotador hacia delante para pasar la faldilla externa por encima de la punta de proa (no la fije de momento). Tire después el flotador hacia atrás.

NOTA

La fijación final de la faldilla exterior debe efectuarse después de inflar el flotador.

A CONTINUACIÓN, PROCEDA AL INFLADO.

FLOTADOR - SISTEMA DE INFLADO

II -3-SISTEMA DE INFLADO

EL INFLADOR

- a. adaptador
- b. extremo del tubo
- c. base del tubo
- d. orificio de inflado

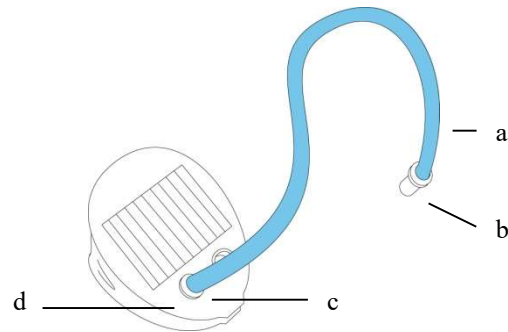

LAS VÁLVULAS "EASY - PUSH"

Para cambiar de posición	en posición de inflado	en posición de desinflado
<p>Empuje</p>	<p>La membrana está cerrada, el pulsador se encuentra en posición alta</p>	<p>La membrana está abierta, el pulsador se encuentra en posición baja</p>

FLOTADOR- PRESIÓN

INFLADO DEL MOTOR

Active todas las válvulas en la posición de inflado.

Fije la base del tubo en el orificio de inflado del inflador.

Para inflar correctamente su embarcación, es necesario que el inflador tenga un buen apoyo en el suelo.

La embarcación se infla rápidamente si el inflador se acciona con suavidad y sin precipitación.



No utilice un compresor ni una bombona de aire comprimido.

FLOTADOR - PRESIÓN

INFLADO DEL FLOTADOR

- Añada el adaptador correspondiente al diámetro de la válvula semiempotrada en el extremo del tubo del inflador.
- Infle el flotador **equilibrando las presiones entre los diferentes compartimentos, hasta que los tabiques (a) ya no sean visibles (presión = 240 mb).**

	<p>Nunca debe ponerse a presión un compartimento mientras los demás están completamente desinflados.</p>	
--	--	--

	1	
--	---	--

	2	
--	---	--

El inflado ha terminado: Enrosque los tapones de las válvulas de inflado.

NOTA:	<p>Es normal detectar una ligera fuga de aire antes del roscado del tapón de la válvula.</p> <p>Los tapones garantizan la estanqueidad final.</p>
--------------	---

FLOTADOR - PRESIÓN

PRESIÓN DE USO

La presión de uso para el flotador es de 240 mb/ 3,4 PSI.

<p>La temperatura ambiente del aire o del agua influyen proporcionalmente sobre el nivel de la presión interna del flotador:</p>	<p>Temperatura ambiente</p>	<p>Presión interna del flotador</p>
	+ 1° C	+ 4 mb / + 0,06 PSI
	- 1° C	- 4 mb / - 0,06 PSI

También es importante saber anticiparse:
Compruebe y regule la presión de los compartimentos inflables (volviendo a inflar o desinflando, según el caso) en función de las variaciones de temperatura (sobre todo

cuando las diferencias de temperatura son importantes entre la mañana y la noche en zonas particularmente cálidas) y asegúrese de que la presión no se encuentre fuera del intervalo de presión recomendada (de 220 a 270 mb / zona verde).

RIESGO DE BAJA PRESIÓN:

Ejemplo: La embarcación está expuesta en la playa a pleno sol (temperatura = 50 °C) con la presión recomendada (240 mb/3,4 PSI). Cuando la ponga en el agua (temperatura = 20 °C), la temperatura y la presión interna de los compartimentos inflables disminuirán conjuntamente (hasta 120 mb), por lo que será necesario volver a inflar hasta ganar los milibares perdidos a causa de la diferencia de temperatura entre el aire ambiente y el agua. En consecuencia, es normal observar una disminución de presión al final del día cuando la temperatura exterior desciende.

RIESGO DE SOBREPRESIÓN:

Ejemplo: La embarcación está inflada con la presión recomendada (240 mb/3,4 PSI) al comienzo o al final del día (temperatura exterior = 10 °C). Más tarde durante el día, la embarcación está expuesta a pleno sol en la playa o en la cubierta de un yate (temperatura = 50 °C). La temperatura interior de los compartimentos inflables puede elevarse y llegar hasta 70 °C (especialmente en los flotadores de color oscuro), lo que implica una duplicación de la presión inicial (480 mb). Así pues, será necesario desinflar para volver a la presión recomendada.



Si su embarcación está demasiado inflada, la presión ejerce un esfuerzo anómalo sobre la estructura inflable, lo que puede provocar una rotura de ensamblaje.

FLOTADOR - PRESIÓN

EN CASO DE SOBREPRESIÓN

Válvula EASY PUSH:
Libere el aire apretando el pulsador de la válvula

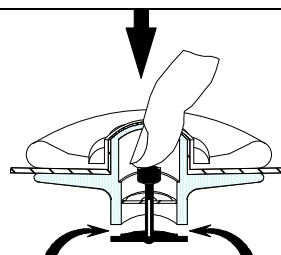

SISTEMA DE PROPULSIÓN

III – Sistema de propulsión

Respete las recomendaciones de ZODIAC y las del fabricante del motor.

Para una utilización óptima de su embarcación, por favor, consulte a su concesionario.

INSTALACIÓN Y CIRCUITOS – COMBUSTIBLE

IV -1-Instalación de combustible

IV -1-1-Depósito

El depósito está situado bajo la consola de pilotaje:

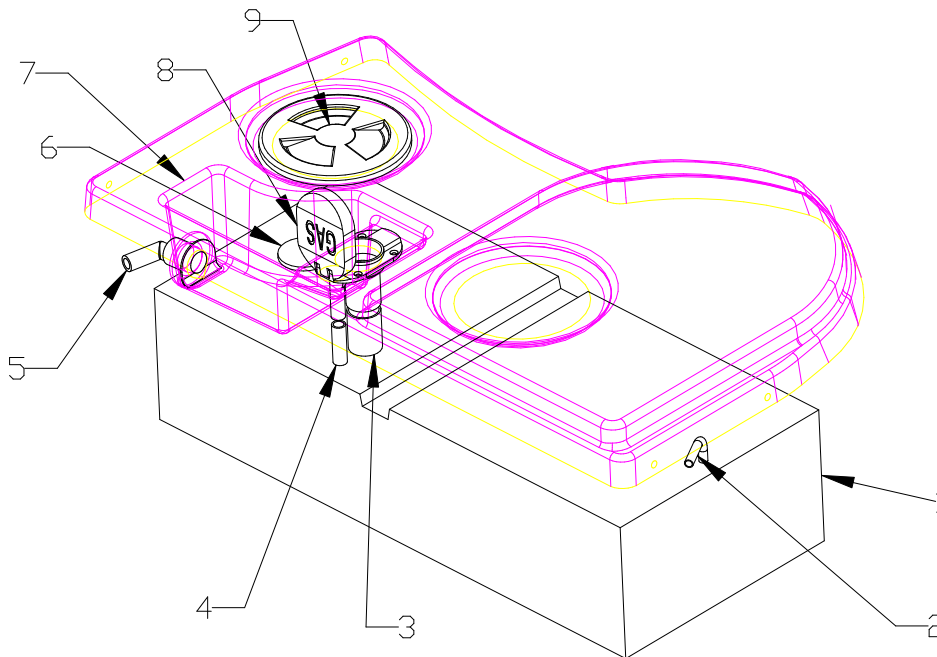

REFERENCIA	DESCRIPCIÓN
1	Depósito
2	Salida para alimentación de motor
3	Orificio de llenado
4	Orificio de respiradero
5	Espiche de vaciado del compartimento del rebosadero
6	Transmisor del indicador de nivel
7	Compartimento de "rebosadero"
8	Tapón de llenado con respiradero integrado
9	Trampilla de mantenimiento de depósito



Es obligatoria la presencia del cuadrante de nivel. Se suministra con el motor. Si no lo tuviera, debe dirigirse a su agente.

La sonda es del tipo estándar americano:

Impedancia (posición de depósito vacío) 30 ohmios

Impedancia (posición de depósito lleno) 240 ohmios

Salvo raras excepciones, todos los cuadrantes del mercado son compatibles.

Para la conexión, consulte el esquema eléctrico de la página 22.

INSTALACIÓN Y CIRCUITOS – DEPÓSITO Y ACCESORIOS

IV-1-2-Filtro separador de agua/gasolina

NOTA:	Para proteger el motor, hay instalado un filtro separador de agua/gasolina en el circuito de alimentación de gasolina del motor.
--------------	---

El filtro separador agua/gasolina está situado en el pañol de popa, sobre el mamparo de estribor:

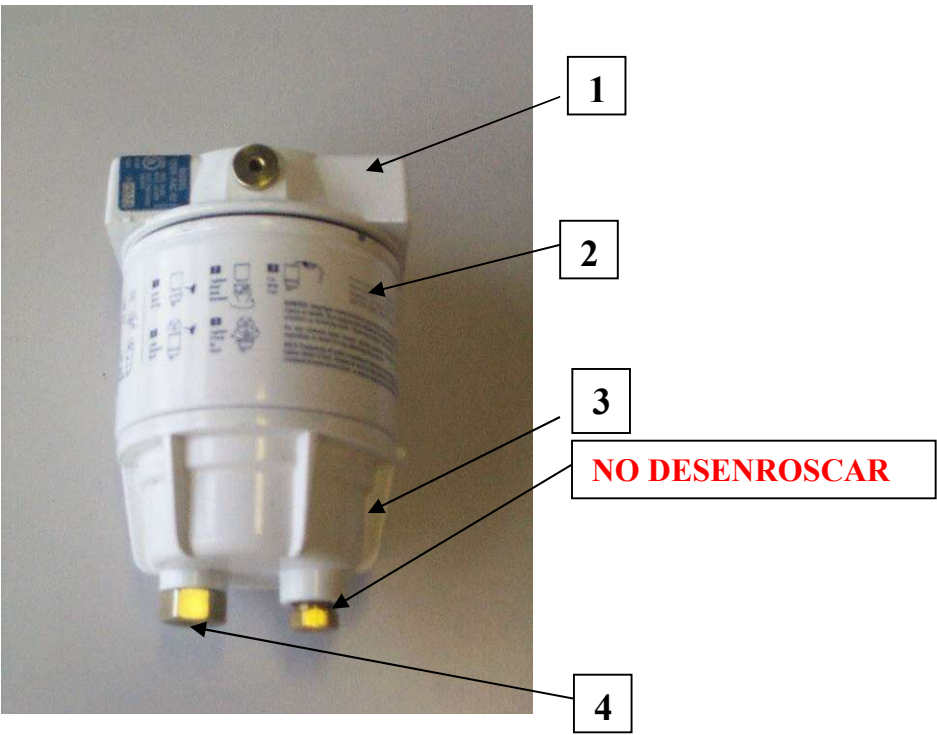

REFERENCIA	DESCRIPCIÓN
1	Cabeza del filtro, fijada en la embarcación
2	Elemento de filtración intercambiable
3	Bol metálico
4	Tornillo de purga

 ADVERTENCIA	No desenrosque el tornillo pequeño: podría dañar la junta y afectar a la estanqueidad del bol.
------------------------	---

NOTA	Compruebe, en cada uso, la ausencia de agua en el bol metálico: Desenrosque ligeramente el tapón de vaciado (no lo quite completamente); vacíe el agua; vuelva a enroscar el tapón si solo hay gasolina en el bol. Repita la operación con más frecuencia si su motor no funciona correctamente.
-------------	---

INSTALACIÓN Y CIRCUITOS – Depósito y accesorios

 <p>ADVERTENCIA</p>	<p>Es indispensable purgar y limpiar regularmente el filtro y cambiar el cartucho al menos una vez al año. El bol metálico es reutilizable.</p>
---	---

Cambio del cartucho del filtro:

Respete las recomendaciones de ZODIAC y del fabricante del filtro.



IV-1-3-Recomendaciones:

 <p>ADVERTENCIA</p>	<ul style="list-style-type: none"><input checked="" type="checkbox"/> Un depósito lleno evita que se produzca condensación cada vez que se salga.<input checked="" type="checkbox"/> Haga limpiar el depósito cada 5 años.<input checked="" type="checkbox"/> Compruebe el apriete de las abrazaderas en todos los tubos flexibles.<input checked="" type="checkbox"/> Al purgar el filtro, no vacíe el agua en la embarcación. Ponga un recipiente de recuperación debajo del filtro.<input checked="" type="checkbox"/> Corte el contacto antes de desmontar el cartucho del filtro.<input checked="" type="checkbox"/> Lea atentamente las instrucciones del manual del filtro.
---	---

 <p>ADVERTENCIA</p>	<ul style="list-style-type: none"><input checked="" type="checkbox"/> La gasolina es extremadamente inflamable. Cuando tenga que intervenir en el sistema de carburación, asegúrese de que los motores estén parados. No fume; aleje cualquier llama o cuerpo incandescente de la zona de trabajo.
---	--

INSTALACIÓN Y CIRCUITOS - ELECTRICIDAD

IV -2-ESQUEMA ELÉCTRICO

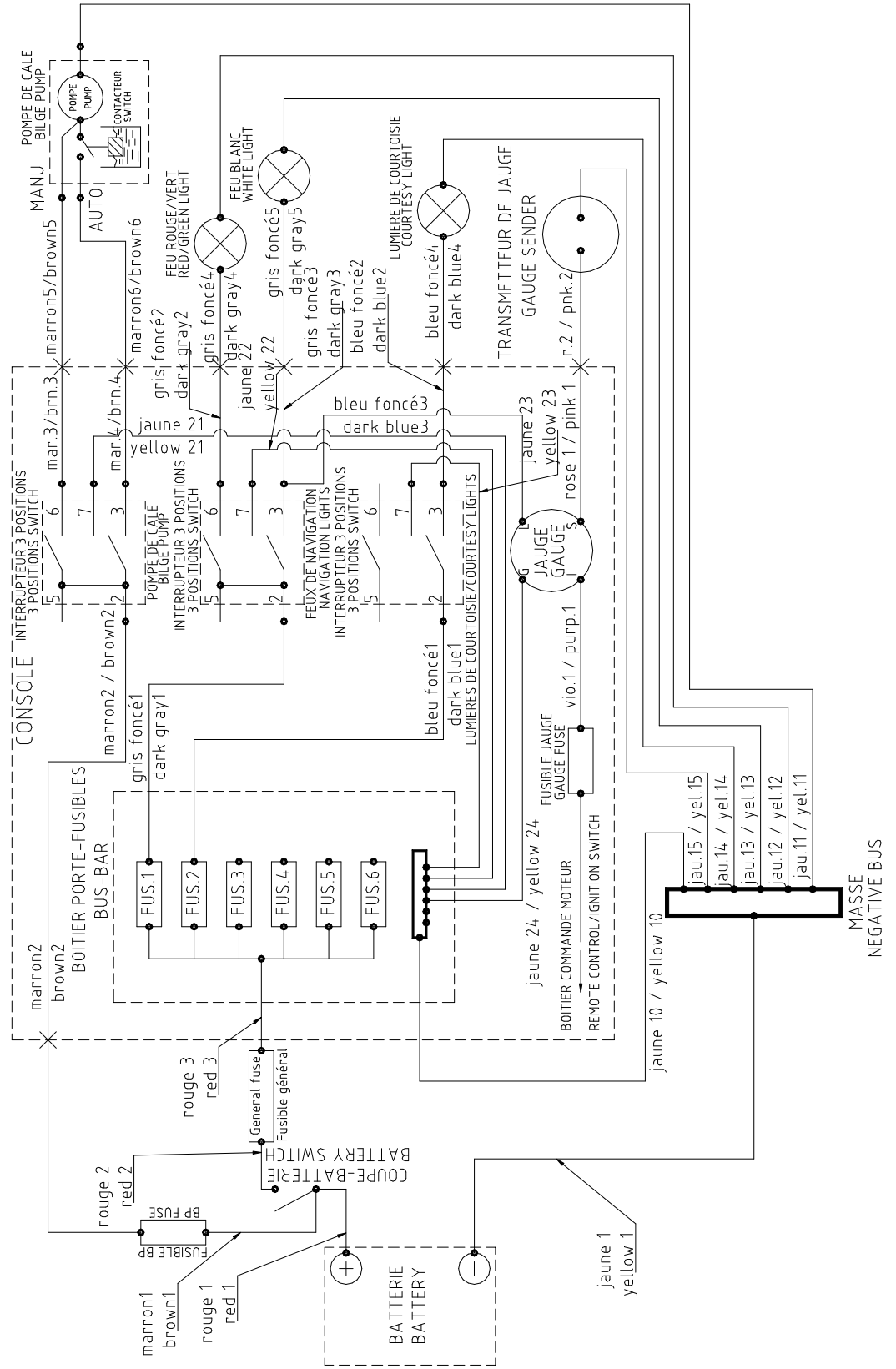



INSTALACIÓN Y CIRCUITOS – CONEXIÓN DE OPCIONES

IV -3-BATERÍA (no incluida)

Para el mantenimiento habitual, respete las recomendaciones de ZODIAC y las del fabricante de baterías.

	<p>Realice el mantenimiento de su batería:</p> <ul style="list-style-type: none"> <input checked="" type="checkbox"/> mantenga limpia y seca la batería para evitar un desgaste prematuro. <input checked="" type="checkbox"/> apriete y mantenga los terminales sobre el borne, engrasándolos regularmente.
---	--

 ATENCIÓN	<p>El agua procedente del sistema de suministro de agua contiene minerales que deterioran las baterías. Por lo tanto, rellene el nivel siempre con agua destilada.</p>
 ADVERTENCIA	<ul style="list-style-type: none"> • Mantenga las baterías y el electrolito fuera del alcance de los niños. • Nunca coloque la batería sobre un costado. • Al añadir electrolito o al cargar la batería, retírela siempre del compartimento del motor. • El electrolito de la batería es un líquido tóxico y peligroso. Contiene ácido sulfúrico, que puede provocar graves quemaduras. Evite cualquier contacto con la piel, los ojos y la ropa. • Las baterías pueden liberar gases explosivos. Aleje las fuentes de chispas, las llamas abiertas, los cigarrillos, etc. • Al cargar o utilizar una batería, trabaje en un lugar bien ventilado. Protéjase siempre los ojos cuando trabaje cerca de una batería.

NOTA:	<ul style="list-style-type: none"> <input checked="" type="checkbox"/> Cuando no utilice su embarcación Zodiac durante un mes o más, retire la batería y guárdela en un lugar fresco, oscuro y seco. Cargue completamente la batería antes de reutilizarla. <input checked="" type="checkbox"/> Si tiene que guardar la batería durante un período más largo, compruebe la densidad del electrolito al menos una vez al mes y cargue la batería cuando la densidad sea demasiado baja. <p>Densidad del electrolito: 1,28 à 20 °C</p>
--------------	---

NOTA:	<p>Cuando no utilice su embarcación, ponga el cortacircuitos en la posición OFF.</p>
--------------	--

INSTALACIÓN Y CIRCUITOS – CONEXIÓN DE OPCIONES

IV -4-ALMACENAMIENTO DEL MÁSTIL DE LUZ DE NAVEGACIÓN



 ADVERTENCIA	<p>Para no dañar el mástil de la luz de navegación cuando cierre el asiento, procure fijarlo siempre como se indica en la foto de arriba.</p>
---	---

NOTA	<p>Para facilitar la colocación del mástil en sus puntos de fijación, se puede aplicar agua jabonosa.</p>
-------------	---

VISTA SUPERIOR:

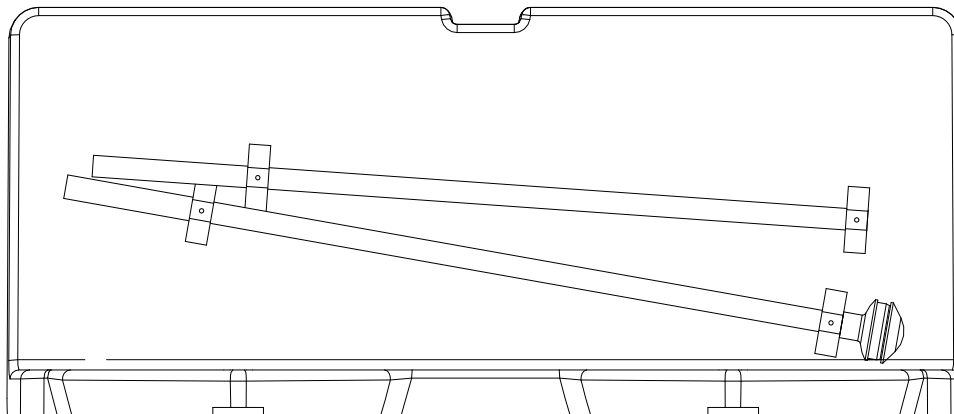

INSTALACIÓN Y CIRCUITOS – Conexión de opciones

IV -5-CONEXIÓN DE OPCIONES

IV-5-1- Precauciones:

La embarcación viene equipada de serie con una bomba de achique, luces de navegación y luz de cubierta. Sin embargo, quedan disponibles 4 emplazamientos en la caja de fusibles (bajo la consola) para la conexión de accesorios suplementarios en ciertas condiciones:

- ① Los accesorios que se desee incluir deberán conectarse en la consola.
- ② Los accesorios se reparten en dos categorías:
 - A** → los que se utilizan o pueden utilizarse de manera continua durante el uso normal de la embarcación,
 - B** → los que se utilizan de forma intermitente.

A	
Ventilador de cala	
Radio	
Sonda	
GPS	
Foco	
Sistema de alarma	
Frigorífico	
VHF	
Σ	180 W máx.

y

B	
Toma de mechero	
Alumbrados diversos	
Bocina	
Equipos electrónicos diversos	
Bomba de ducha	
Potencia máx. adoptada	72 W máx.

 ADVERTENCIA	<p>Es imprescindible confirmar que la suma de las potencias de los accesorios de la columna A que usted <u>añada</u> sea inferior o igual a 180 W (15 A) <u>Y</u> que la potencia máxima de un accesorio de la columna B sea inferior o igual a 72 W (6 A).</p> <p>Las secciones de los diferentes cables del haz han sido calculadas con estos valores; el incumplimiento de esta regla puede provocar problemas de funcionamiento eléctricos y cortocircuitos.</p>
---	--

NOTA:	<p>Si instala numerosos equipos eléctricos. El consumo instantáneo total podría superar eventualmente la capacidad de carga de su motor fueraborda. Por ejemplo, el haz eléctrico puede aceptar un consumo instantáneo de 285 W (incluidas las luces de navegación y la bomba de achique), o sea, un poco menos de 24 A de intensidad de corriente. Los alternadores de los motores actuales suministran generalmente una intensidad de 15 A, a plena potencia (verifíquelo en la documentación técnica del motor). Debe evitar usar esos aparatos de forma prolongada, para prevenir el riesgo de agotar la batería y no poder volver a arrancar el motor.</p>
--------------	---

INSTALACIÓN Y CIRCUITOS – Conexión de opciones

Ejemplo 1

Desea añadir:
 Una VHF de 72 W,
 Un GPS de 36 W,
 Una radio de 60 W,
 Un mechero de 72 W,
 Un reloj de 20 W.

A	
Ventilador de cala	
Radio	60 W
Sonda	
GPS	36 W
Foco	
Sistema de alarma	
Frigorífico	
VHF	72 W
Σ	168 W (< 180 W) ☺

y

B	
Alumbrados diversos	
Equipos electrónicos diversos	20 W (reloj)
Bomba de ducha	
Potencia máx. adoptada	20 W (< 72 W) ☺

CONCLUSIÓN	
------------	---

Ejemplo 2

Desea añadir:
 Una VHF de 60 W,
 Un GPS de 36 W,
 Una radio de 48 W,
 Un foco de 120 W.

A	
Ventilador de cala	
Radio	48 W
Sonda	
GPS	36 W
Foco	120 W
Sistema de alarma	
Frigorífico	
VHF	60 W
Σ	264 W (> 180 W) ☹

y

B	
Alumbrados diversos	
Equipos electrónicos diversos	
Bomba de ducha	
Potencia máx. adoptada	0 (< 72 W) ☹

CONCLUSIÓN	
------------	---

INSTALACIÓN Y CIRCUITOS – Conexión de opciones

Ejemplo 3

Desea añadir:

Un GPS de 60 W,

Una radio de 60 W,

Una bocina de 120 W.

A	
Ventilador de cala	
Radio	60 W
Sonda	
GPS	60 W
Foco	
Sistema de alarma	
Frigorífico	
VHF	
Σ	120 W (< 180 W) ↻

y

B	
Alumbrados diversos	
Equipos electrónicos diversos	120 W
Bomba de ducha	
Potencia máx. adoptada	120 W (> 72 W) ↻

CONCLUSIÓN	
------------	---

NOTA	Algunos fabricantes le indicarán el amperaje en lugar de la potencia absorbida. En corriente continua con una batería de 12 V (que es nuestro caso), basta con multiplicar por 12 para obtener la potencia.
-------------	--

IV-5-2-Cableado:

- ① Elija un emplazamiento de fusible libre.
- ② Conecte el cable de alimentación de su accesorio en el borne correspondiente a este emplazamiento con un "terminal lengüeta" hembra de 6 mm.
- ③ Si tiene que añadir un cable para la conexión, es necesario utilizar un cable con una sección mínima de 1,5 mm² y respetar las recomendaciones sobre cable "marino" (UL1426 o SAE J378 o SAE J1127 o SAE J1128 o que, de forma general, responda a las recomendaciones ABYC y/o CE).
- ④ Conecte el cable de masa de su accesorio en la placa de bornes de masa con un "terminal de ojo" de Ø5 (misma observación que anteriormente para el cable).
- ⑤ Inserte un fusible de tipo ATO de intensidad máxima de 15 A y superior a la intensidad de utilización de su aparato.

IV -5-3-Conexión de nivel de gasolina:

Realice la conexión según las indicaciones del esquema (página 19).

INSTALACIÓN Y CIRCUITOS – Conexión de opciones

IV -5-4-Instalación de accesorios en la consola:

En función del nivel de equipamiento de su embarcación, ZODIAC recomienda la configuración siguiente (véanse las plantillas de perforación suministradas con la embarcación), que optimiza el espacio disponible.

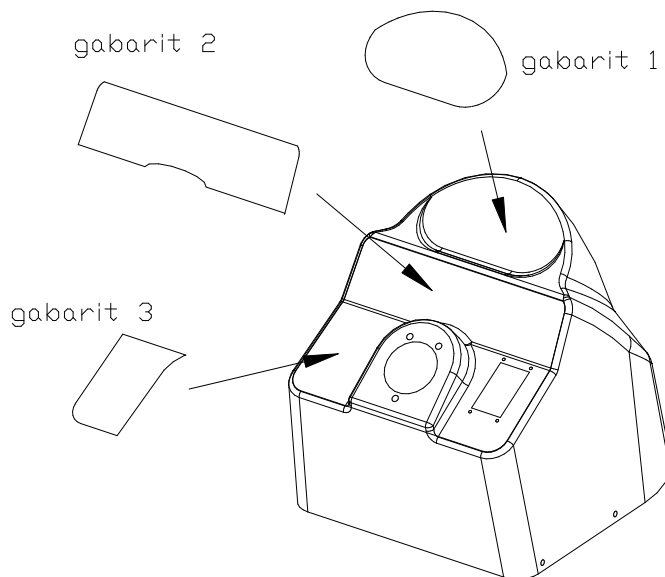

IV -6-FUNCIONAMIENTO DE LA BOMBA DE ACHIQUE

El funcionamiento de la bomba de achique es independiente de la posición del interruptor de la batería; el interruptor de mando  siempre está en tensión.

- ① Funcionamiento automático (posición fija): en esta posición, el funcionamiento de la bomba de achique es automático. El indicador luminoso está encendido.
- ② Parada: en esta posición (posición fija), la bomba de achique está parada. El indicador luminoso está apagado.
- ③ Marcha forzada: hay que mantener pulsado el interruptor para obtener un funcionamiento en marcha forzada. Cuando se deja de pulsar, el interruptor vuelve a la posición de parada (2).

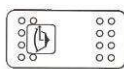

 ADVERTENCIA	<p>En el fondeo, ponga el interruptor de la bomba de achique en la posición de funcionamiento automático.</p>
---	--

NOTA	<p>ZODIAC recomienda utilizar un toldo o una lona de fondeo para impedir la entrada de agua en caso de lluvia.</p>
-------------	---



ADVERTENCIA

Hay que hacer hincapié en los procesos de acabado en los que los elementos estructurales, como las consolas de dirección, los asientos o superestructuras, por ejemplo, sean instalados por terceras personas ajenas al fabricante de la embarcación. Es necesario que estos elementos se instalen de forma que cumplan las exigencias pertinentes de la ISO 6185-3, para garantizar que todas ellas no invaliden la evaluación inicial.

Asegúrese también de que la instalación posterior de consolas y demás elementos estructurales no incluidos inicialmente con la embarcación, se realice siguiendo los consejos de instalación facilitados por el fabricante y las recomendaciones de ZODIAC.



ZNAUTIC GROUP

2 chemin de la Val Priout
31450 AYGUESVIVES
FRANCIA

YACHTLINE 360 - 400



Volume 2

***YACHTLINE
360/400***

611133 A



LEGGERE ATTENTAMENTE QUESTO MANUALE PRIMA DELLA MESSA IN SERVIZIO DEL
PROPRIO ZODIAC

VOLUME 2
DESCRIZIONE - TUBOLARE
SISTEMA DI PROPULSIONE
IMPIANTI E CIRCUITI

INDICE





	PAGIN A
⇒ I - DESCRIZIONI GENERALI	
I-1- Caratteristiche tecniche -----	2 - 3
I-2- Inventario -----	4 - 5
I-3- Ubicazione degli elementi -----	6 - 7
I-4- Movimentazione -----	8 - 10

⇒ II- TUBOLARE	
II-1- Fasi principali della messa in servizio del tubolare -----	11
II-2- Montaggio del tubolare sullo scafo -----	12 - 13
II-3- Sistema di gonfiaggio -----	14
II-4- Pressione -----	14 - 16
⇒ III - SISTEMA DI PROPULSIONE	17
⇒ IV - IMPIANTI E CIRCUITI	
IV-1- Impianto del carburante -----	18 - 20



IV-2- Schema elettrico -----	21
IV-3- Batteria -----	22
IV-4- Rimessaggio dell'albero per luci di navigazione -----	23
IV-5- Allacciamento di optional -----	24 - 26
IV-6- Funzionamento della pompa di sentina -----	27



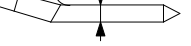

DESCRIZIONE - CARATTERISTICHE TECNICHE

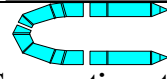

I-1 CARATTERISTICHE TECNICHE

Dimensioni			
		YL 360	YL 400
	(m)	3,60	4,00
	(ft)	11' 8"	13' 1"
	(m)	2	2,40
	(ft)	6' 7"	7' 10"
	(m)	1,77	1,77
	(ft)	5' 10"	5' 10"
	(m)	0,86	0,86
	(ft)	2' 10"	2' 10"
	(m)	0,455	0,455
	(ft)	1' 6"	1' 6"

Certificazione	
 (Direttiva 94/25/CE)	C

Capacità			
		YL 360	YL 400
 (ISO)		4	5
 Maximum	kg ⁽¹⁾	605	735
	lb ⁽¹⁾	1.334	1.621
 Maximum	kg ⁽²⁾	200	218
	lb ⁽²⁾	441	481
 Compartimento		3	3

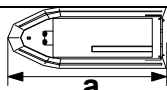
Motorizzazione			
		YL 360	YL 400
 Long			
	Potenza MIN raccomandata	CV ⁽³⁾	15
		kW ⁽³⁾	12
	Potenza MAX raccomandata	CV	40
		kW	30
	Potenza MAX consentita	CV ⁽³⁾	40
		kW ⁽³⁾	30
 Maximum	Peso MAX motore	kg	119
		lb	262

Dimensioni			
		YL 360	YL 400
 a	a ⁽⁴⁾	3,18 m	3,58 m
		10' 5"	11' 9"
 b	b ⁽⁴⁾	1,40 m	1,40 m
		4' 6"	4' 6"
 c	c ⁽⁴⁾	0,98 m	0,98 m
		3' 2"	3' 2"

DESCRIZIONE - CARATTERISTICHE TECNICHE

NOTA	Tolleranze sulle dimensioni: +/- 4%
------	-------------------------------------

NOTA	<p>⁽¹⁾ Il carico massimo consentito è stato calcolato in conformità alla norma ISO 6185. In condizioni di carico massimo si raccomanda di navigare con particolare prudenza.</p> <p>⁽²⁾ Pesi indicati senza accessori</p> <p>⁽³⁾ Le potenze raccomandate corrispondono a uno sfruttamento ottimale delle capacità dell'imbarcazione con carico medio (4 persone).</p> <p>⁽⁴⁾ Dimensioni dello scafo senza tubolare.</p> <p>Utilizzare la potenza massima consentita con estrema prudenza (vedere Volume 1 del manuale, capitolo "Consigli per la navigazione").</p>
------	---

 ATTENZIONE	Il carico massimo indicato sulla targa del costruttore non deve essere superato per alcun motivo. Il carico massimo comprende la massa del motore, del carburante, degli accessori, dei passeggeri e del loro equipaggiamento, nonché di qualsiasi altro tipo di carico.
--	--

 ATTENZIONE	Non stivare prodotti infiammabili nel gavone di poppa. È severamente vietato imbarcare un serbatoio ausiliario.
---	---

SOLTANTO SU 400 DL:

 AVVERTENZA	<p>Manovrabilità limitata sopra i 25 nodi.</p> <p>Rischio di perdita del controllo in caso di virate strette.</p> <p>Ridurre la velocità* prima di effettuare una virata in qualunque direzione.</p> <p>(*) È inoltre possibile agire sul power trim e rientrare il motore verso il rispettivo supporto.</p>
---	---

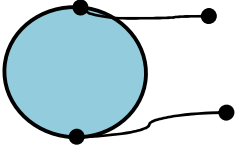
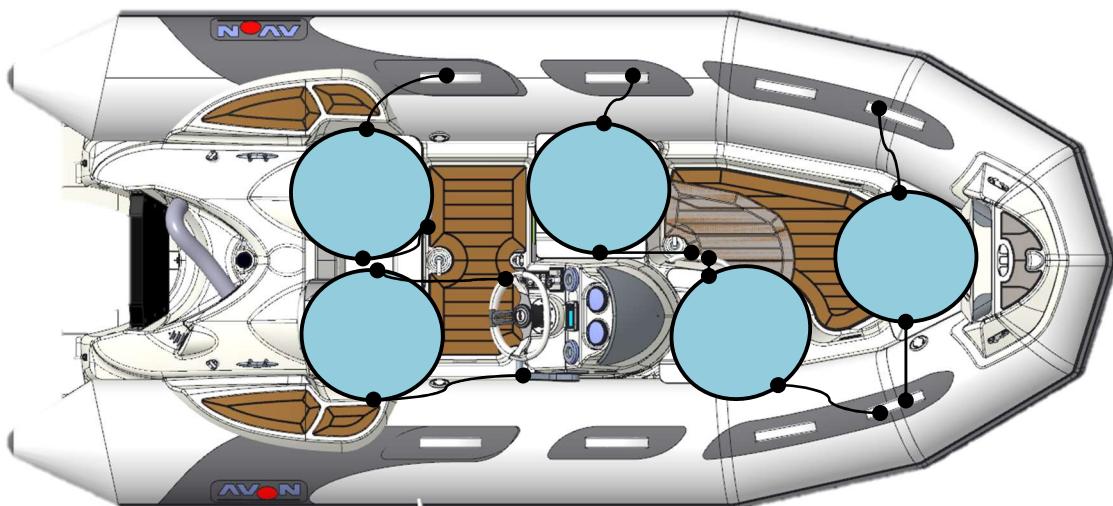

Sedile con impugnature per Yachtline 400

DESCRIZIONE - INVENTARIO

I-2- INVENTARIO

SCAFO
• Scafo in poliestere
• Coperta a controstampo antiscivolo
• Specchio di poppa riportato e carena a "flap"
• Consolle con vano
• 1 Golfare del dritto di prua
• 1 Gavone d'ancoraggio + gavone davanti alla consolle (soltanto su 400 YL)
• 1 Gavone di poppa
• 4 Sedili con cuscineria su 360 YL (5 sedili su 400 YL)
• 2 Galloce d'ormeggio di poppa
• 1 Marciapiede in poliestere con galloccia d'ormeggio luci di navigazione e LED
• 1 Albero per luce bianca pieghevole e amovibile
• 1 Illuminazione coperta
• 3 Lande articolate di sollevamento
• 2 Lande di trazione
• 2 Scarichi rapidi + 1 foro di alleggio dello scafo

TUBOLARE
• Tubolare amovibile
• Tessuto Neoprene Hypalon 1100 decitex
• Valvole Easy-Push
• Bottazzo antiabrasione a profilo largo
• 6 Maniglie
• Rinforzi dei coni

CONSOLLE
• Volano e comando di direzione a distanza
• 3 Interruttori
• Vano portaoggetti

DESCRIZIONE - INVENTARIO

EQUIPAGGIAMENTO STANDARD
• 1 Serbatoio fisso (35 litri + trasmettitore livello carburante + separatore acqua/benzina) con sfiato e dispositivo anti-traboccamento
• Luci di navigazione e illuminazione coperta
• 1 Vano batteria
• 1 Interruttore di batteria
• Pre-equipaggiamento elettrico per l'aggiunta di accessori supplementari
• 1 Pompa di sentina
• 2 Remi
• 1 Pompa a pedale
• 1 Valigetta per le riparazioni
• 1 Manuale del proprietario (2 volumi)
• 1 Tappo manometro

ACCESSORI OPTIONAL
• Kit di sollevamento
• Scaletta bagno
• Schienale posteriore
• Coperta in teck sintetico
• Salto di vento

DESCRIZIONE - UBICAZIONE DEGLI ELEMENTI

I-3- UBICAZIONE DEGLI ELEMENTI

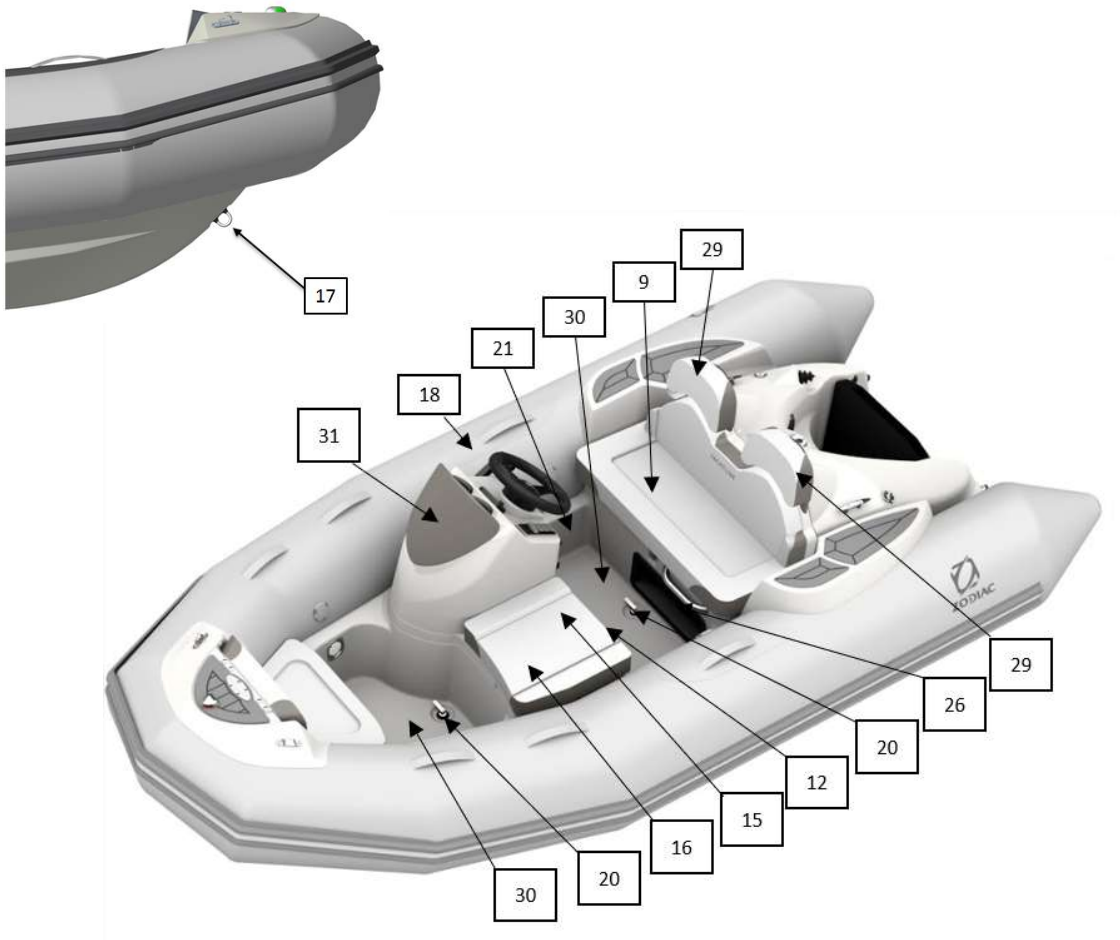
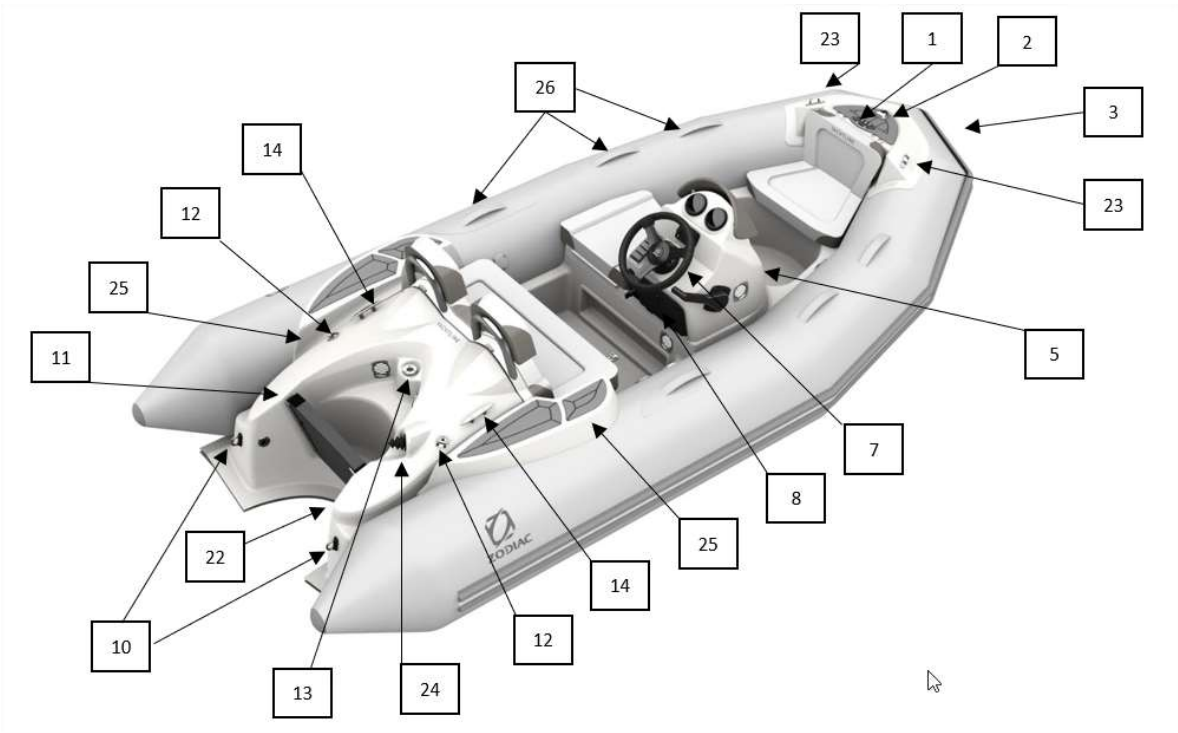

DESCRIZIONE - UBICAZIONE DEGLI ELEMENTI

RIF.	DESCRIZIONE
1	Galloccia d'ormeggio di prua
2	Luci di navigazione
3	Pedana in poliestere di prua
4	Gavone d'ancoraggio
5	Consolle
6	Interruttori
7	Volano
8	Vano portaogetti
9	Sedile di poppa basculante
10	Golfari di traino/ormeggio
11	Specchio di poppa
12	Golfari di sollevamento
13	Base dell'albero per luce bianca
14	Gallosce d'ormeggio di poppa
15	Sistema di riempimento serbatoio
16	Botola d'accesso manutenzione serbatoio
17	Golfare del dritto di prua
18	Tubolare
19	Supporto estintore
20	Scarico rapido
21	Illuminazione della coperta
22	Foro di aleggio
23	Passacatena
24	Passacavo
25	Pedana in poliestere
26	Maniglia
27	Valvola Easy-Push
28	Presa per accendisigari 12 V
29	Schienale posteriore
30	Coperta in teck sintetico
31	Salto di vento

DESCRIZIONE – MOVIMENTAZIONE

I-4 MOVIMENTAZIONE

I-4-1- Trasporto:

•I consigli per il trasporto su rimorchio sono forniti nel manuale del proprietario VOLUME I.

I-4-2- Rimessaggio:

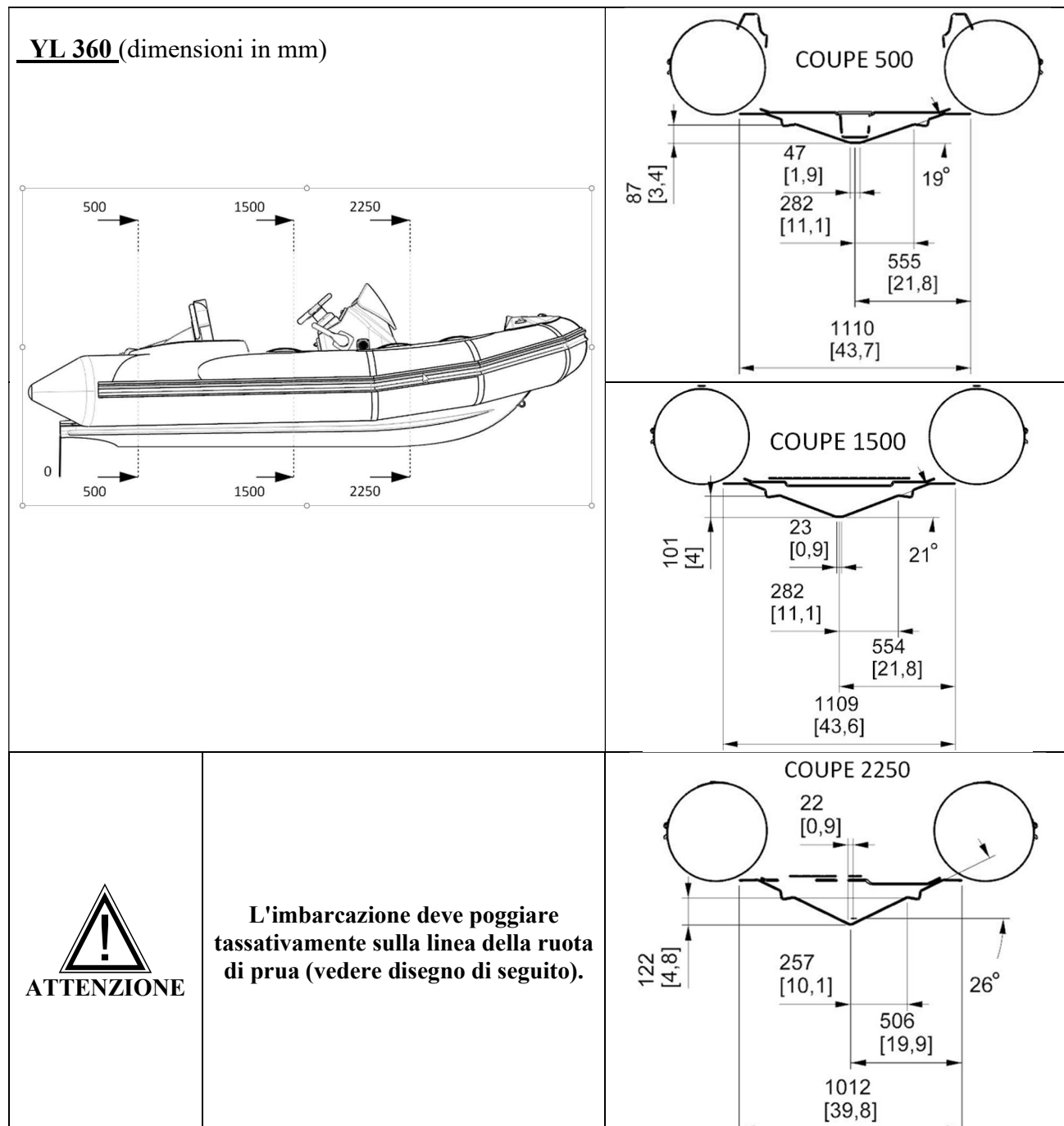

YL 400 (dimensioni in mm)

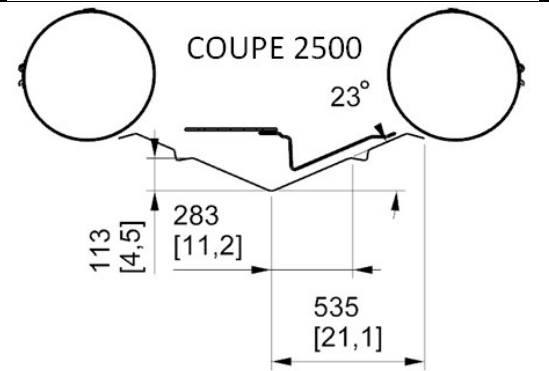
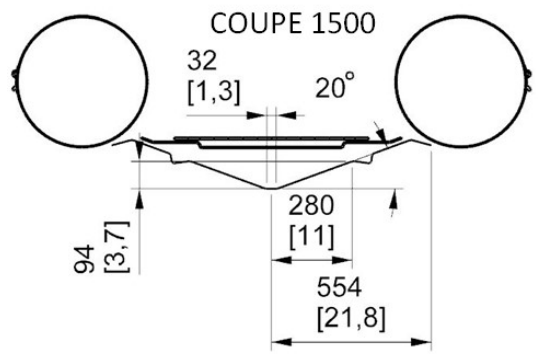
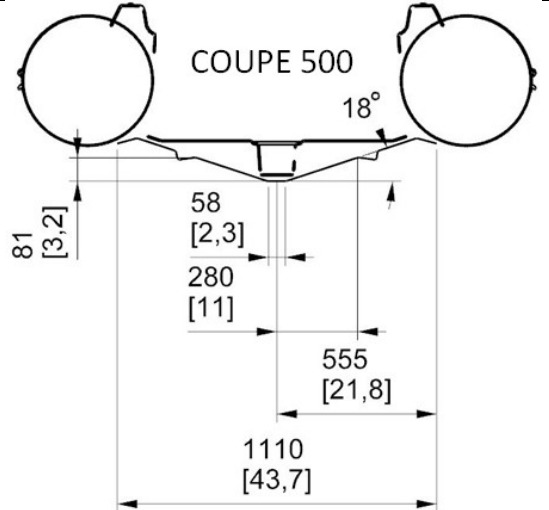
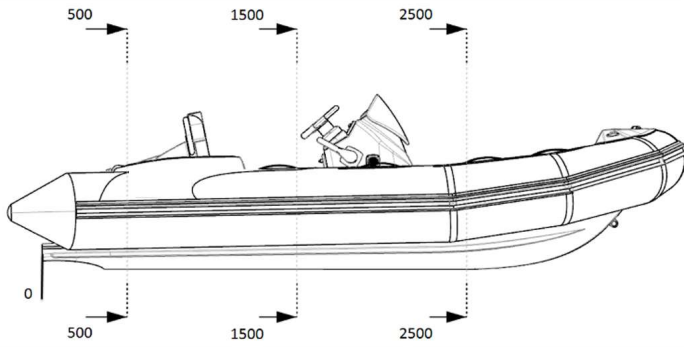

L'imbarcazione deve poggiare tassativamente sulla linea della ruota di prua (vedere disegno di seguito).

DESCRIZIONE – MOVIMENTAZIONE

I-4-3- Sollevamento:

 AVVERTENZA	<p>La braca di sollevamento è proposta come accessorio; per il sollevamento è necessario utilizzare esclusivamente una braca Avon.</p>
--	--

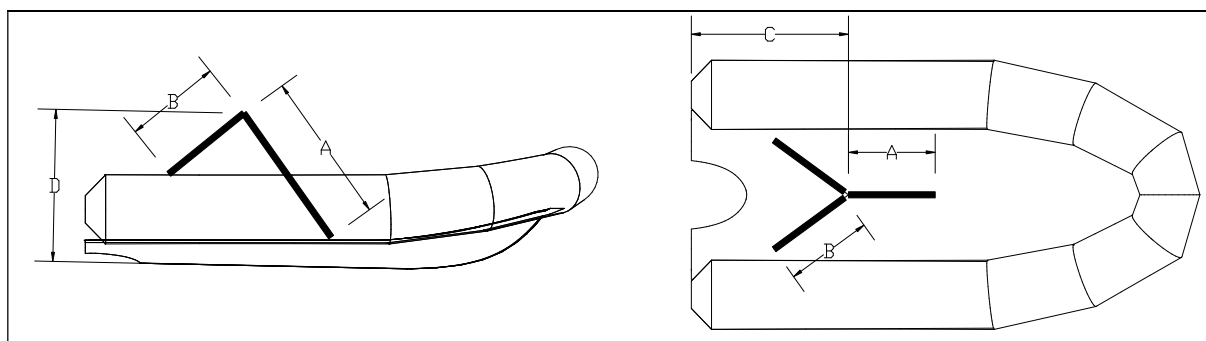

Valori forniti esclusivamente a titolo indicativo		A	B	C	D
360 YL	(m)	1,25	1	1,45	1,4
	(ft)	4' 1"	3' 3"	4' 8"	4' 6"
400 YL	(m)	1,25	1	1,45	1,4
	(ft)	4' 1"	3' 3"	4' 8"	4' 6"

 AVVERTENZA	<p>Nessun passeggero a bordo durante il gruaggio.</p>
--	---

 ATTENZIONE	<ul style="list-style-type: none"> In caso di gruaggio o di posizionamento sulla gru, tutto il materiale deve essere scaricato dall'imbarcazione. Gli scarichi rapidi di coperta (rif. 20*) e il foro di alleggio (rif. 22*) devono essere aperti per garantire lo scarico eventuale dell'acqua piovana dal pozzetto. <p style="margin-left: 20px;">* vedere capitolo I-3 "Ubicazione degli elementi"</p>
--	---

TUBOLARE - MESSA IN SERVIZIO

II-1- FASI PRINCIPALI DELLA MESSA IN SERVIZIO DEL TUBOLARE

La procedura di montaggio dell'imbarcazione deve attenersi a una determinata sequenza che si raccomanda di rispettare. Procedere fase dopo fase, consultando ogni volta le pagine indicate per la spiegazione della procedura.

PROCEDURA	PAGINA	SEZIONE
1. Procedere all'inventario degli elementi che compongono l'imbarcazione e imparare a riconoscerli	4-5	Inventario all'apertura
	6-7	Ubicazione degli elementi
2. Montare il tubolare sullo scafo.	11	Montaggio del tubolare
3. Fissare il grembiule interno	12	Fissaggio del grembiule
4. Posizionare il grembiule esterno		
5. Portare le valvole in posizione di gonfiaggio	14	Sistema di gonfiaggio
6. Procedere al gonfiaggio dell'imbarcazione secondo le pressioni d'uso	15	Gonfiaggio dell'imbarcazione
	16-17	Pressione
7. Fissare il grembiule esterno	12	Fissaggio del grembiule

TUBOLARE - MESSA IN SERVIZIO

II-2 MONTAGGIO DEL TUBOLARE SULLO SCAFO



SE IL TUBOLARE È STATO STOCCATO A UNA TEMPERATURA INFERIORE A 0°C, LASCIARLO PER 12 ORE IN UN LUOGO TEMPERATO (20°C) PRIMA DI APRIRLO.

NOTA

Il tubolare dev'essere montato sullo scafo **sgonfio**.

1

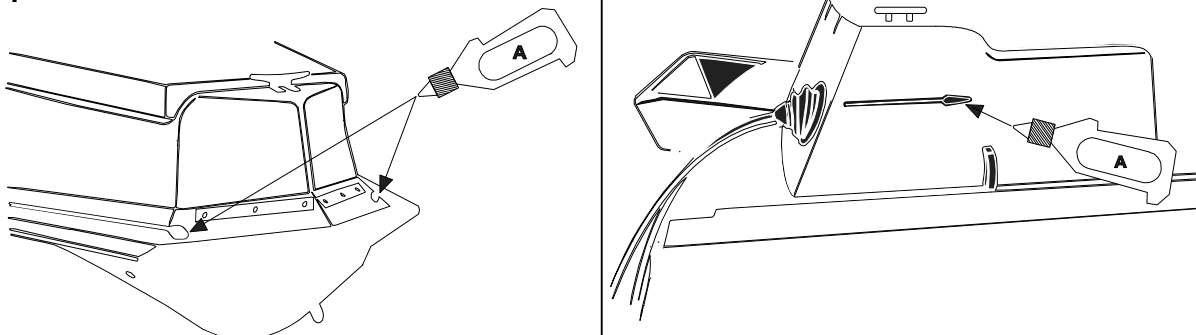

Per agevolare l'installazione del tubolare, cospargere le guide dello scafo con un po' di sapone liquido (A)

2

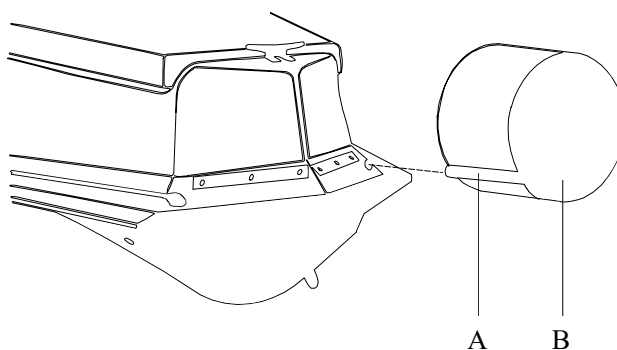

Posizionare la ralinga (a) del tubolare (b) nella guida dello scafo

3

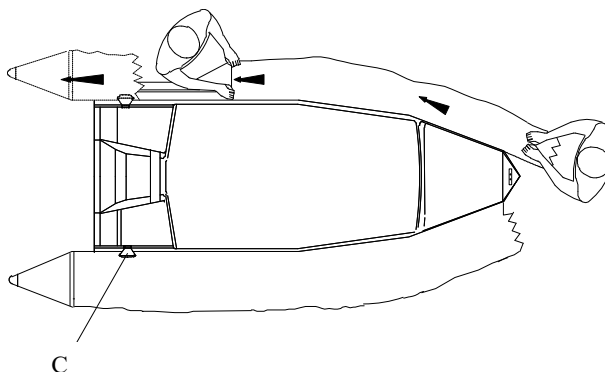

- Tirare il tubolare verso la poppa dell'imbarcazione (non dimenticare di guidare la ralinga superiore C).

- Procedere in maniera analoga per l'altro lato del tubolare

TUBOLARE - MESSA IN SERVIZIO

4

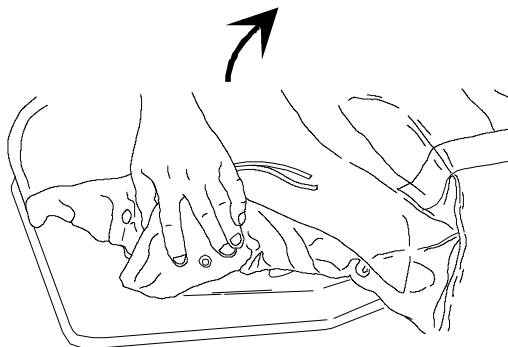

Posizionare il grembiule interno

5

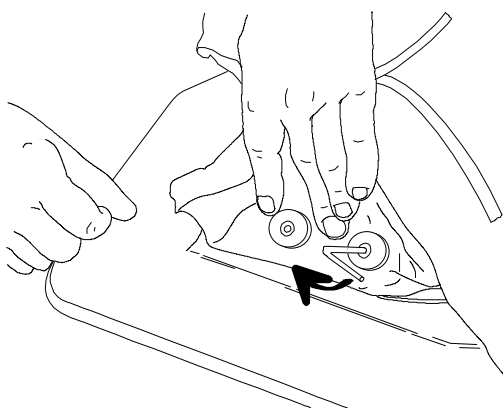

6

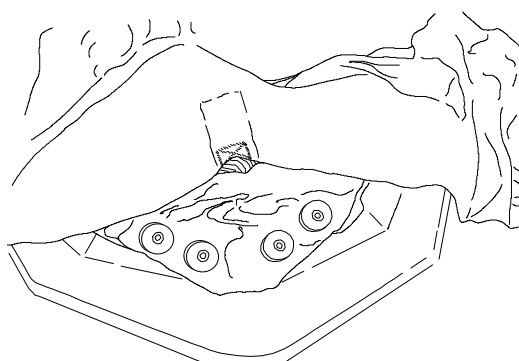

Fissare il grembiule interno

7

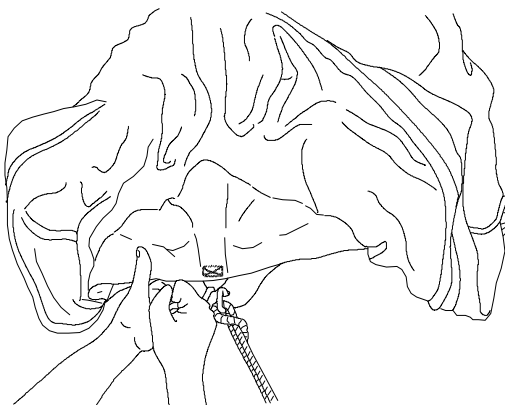

Dopo il fissaggio del grembiule interno sullo scafo, tirare leggermente il tubolare in avanti per passare il grembiule esterno da sopra la punta davanti (non attaccarla ancora). In seguito, tirare indietro il tubolare.

NOTA

Il fissaggio definitivo del grembiule **esterno** dev'essere effettuato **dopo aver gonfiato il tubolare**

IN SEGUITO, PROCEDERE AL GONFIAGGIO

TUBOLARE - SISTEMA DI GONFIAGGIO

II-3- SISTEMA DI GONFIAGGIO

LA POMPA DI GONFIAGGIO

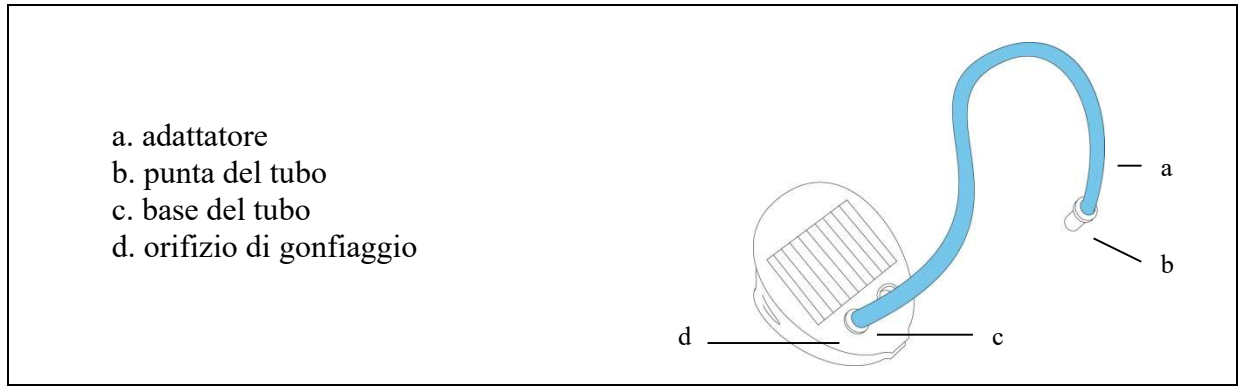

LE VALVOLE "EASY-PUSH"

Per modificare la posizione	in posizione di gonfiaggio	in posizione di sgonfiaggio
 Spingere	 La membrana è chiusa, il pulsante è in posizione sollevata	 La membrana è aperta, il pulsante è in posizione abbassata

TUBOLARE- PRESSIONE

GONFIAGGIO DEL MOTORE

Portare tutte le valvole in posizione di gonfiaggio.

Fissare la base del tubo all'orifizio di gonfiaggio della pompa.
 Per gonfiare correttamente l'imbarcazione, occorre che la pompa abbia un assetto stabile a terra.
 L'imbarcazione si gonfia rapidamente qualora la pompa di gonfiaggio sia azionata delicatamente e lentamente.

 ATTENZIONE	<p>Non utilizzare compressori o bombole ad aria compressa.</p>
-----------------------	---

TUBOLARE - PRESSIONE

GONFIAGGIO DEL TUBOLARE

- Aggiungere l'adattatore corrispondente al diametro della valvola parzialmente incassata alla punta del tubo della pompa.
 Procedere al gonfiaggio del tubolare **equilibrando le pressioni tra i diversi compartimenti, finché i compartimenti stagni (a) non siano più visibili (pressione = 240 mb)**

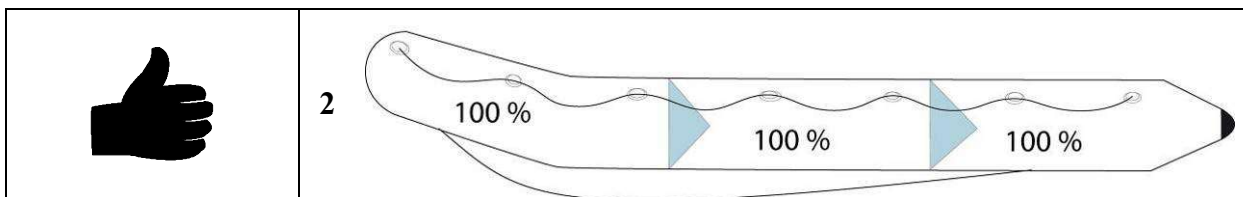
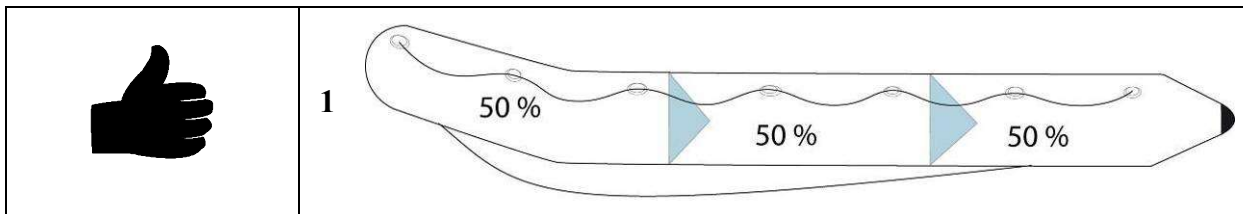
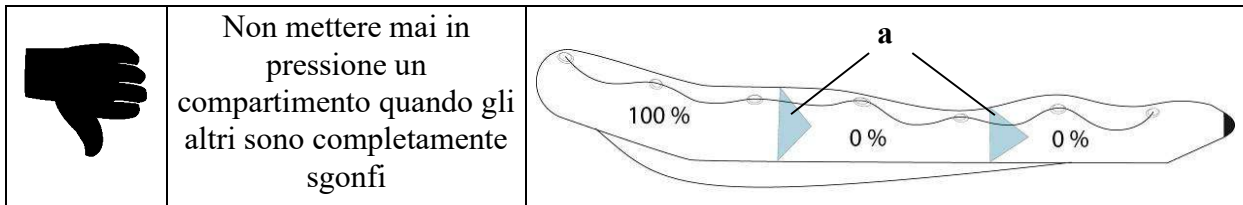

Una volta terminato il gonfiaggio: Avvitare i tappi delle valvole di gonfiaggio.

NOTA:	Una leggera fuoriuscita d'aria prima dell'avvitamento del tappo della valvola è un fattore normale. Solo i tappi garantiscono l'ermeticità finale.
--------------	--

TUBOLARE - PRESSIONE

PRESSIONE D'USO

La pressione d'uso del tubolare è pari a 240 mb / 3,4 PSI.

La temperatura ambiente dell'aria o dell'acqua influisce in modo proporzionale sul livello della pressione interna del tubolare	Temperatura ambiente	Pressione interna del tubolare
	+ 1° C	+ 4 mb/+ 0,06 PSI
	- 1° C	- 4 mb/- 0,06 PSI

Inoltre, è importante saper valutare in anticipo quanto segue:

Verificare e regolare la pressione dei compartimenti gonfiabili (rigonfiando o sgonfiando, a seconda dei casi) in funzione delle variazioni di temperatura (soprattutto quando gli sbalzi sono importanti tra la mattina e la sera, nelle zone particolarmente calde) e accertarsi che la pressione non sia troppo diversa rispetto a quella raccomandata (da 220 a 270 mb/zona verde).

RISCHIO DI SOTTOPRESSIONE:

Esempio: L'imbarcazione è esposta ai raggi diretti del sole sulla spiaggia (temperatura = 50°C) alla pressione raccomandata (240 mb/3,4 PSI). Dopo aver messo l'imbarcazione in acqua (temperatura = 20°C), la temperatura e la pressione interna dei compartimenti gonfiabili diminuiscono (fino a 120 mb C) e **sarà necessario rigonfiarli** fino a recuperare i millibar perduti a causa degli sbalzi di temperatura tra l'aria e l'acqua. Pertanto, è normale constatare una diminuzione di pressione alla fine della giornata, quando la temperatura si abbassa.

RISCHIO DI SOVRAPRESSIONE:

Esempio: L'imbarcazione è gonfiata alla pressione consigliata (240 mb/3,4 PSI) all'inizio o alla fine della giornata (temperatura esterna = 10°C). Più tardi, l'imbarcazione viene esposta ai raggi diretti del sole sulla spiaggia o sulla coperta di uno yacht (temperatura = 50°C). La temperatura interna dei compartimenti gonfiabili può quindi alzarsi fino a 70°C (soprattutto i tubolari di colore scuro) implicando un raddoppio del valore di pressione di partenza (480 mb). **Occorre dunque sgonfiare i tubolari** per tornare alla pressione raccomandata.

 <p>ATTENZIONE</p>	<p>Se l'imbarcazione è troppo gonfia, la pressione sollecita la struttura gonfiabile in modo anomalo e si può verificare una rottura del tessuto.</p>
--	---

TUBOLARE - PRESSIONE

IN CASO DI SOVRAPRESSIONE

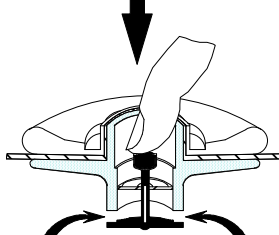
<p>VALVOLA EASY-PUSH: Liberare l'aria premendo sul pulsante della valvola</p>	
--	--

SISTEMA DI PROPULSIONE

III - Sistema di propulsione

Attenersi alle raccomandazioni Zodiac e a quelle del costruttore del motore.

Per un uso ottimale dell'imbarcazione, si prega di rivolgersi al proprio concessionario.

IMPIANTI E CIRCUITI - CARBURANTE

IV-1- Impianto del carburante

IV-1-1- Serbatoio

Il serbatoio è posto sotto la consolle di guida:

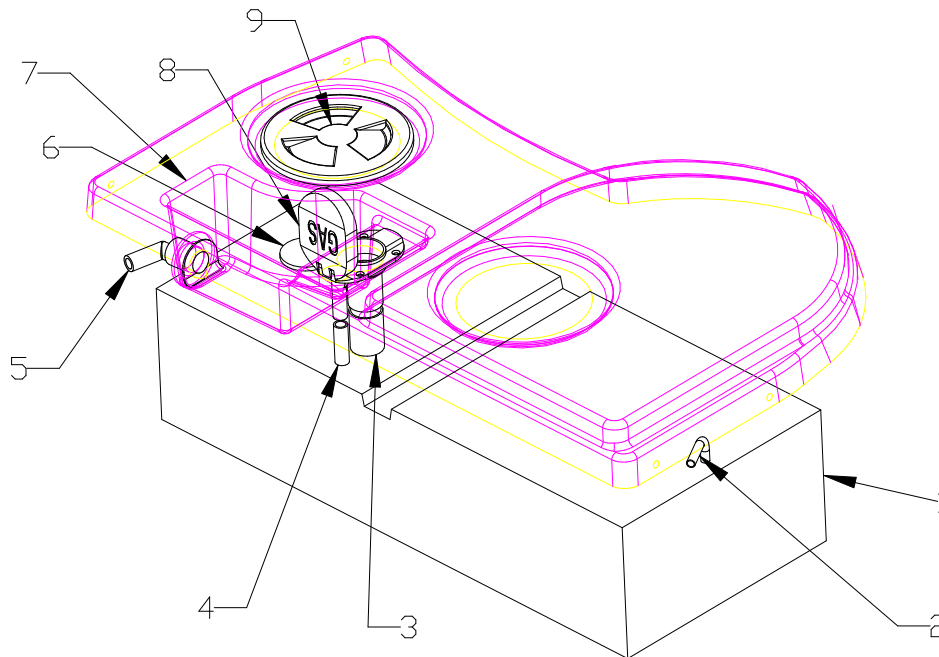

RIF.	DESCRIZIONE
1	Serbatoio
2	Uscita per alimentazione motore
3	Orifizio di riempimento
4	Orifizio di sfiato
5	Foro di aleggio del comparto "traboccamento"
6	Trasmittitore di livello
7	Comparto "traboccamento"
8	Tappo di riempimento con sfiato integrato
9	Botola di manutenzione serbatoio

 ATTENZIONE	<p>La presenza del quadrante di livello è obbligatoria. Questo è fornito con il motore. In caso di assenza, rivolgersi al proprio agente.</p>
--	--

La sonda è di tipo standard americano, ossia:

Impedenza (posizione serbatoio vuoto) 30 Ohm

Impedenza (posizione serbatoio pieno) 240 Ohm

Salvo rarissime eccezioni, tutti i quadranti sul mercato sono compatibili.

Per l'allacciamento, fare riferimento allo schema elettrico di pagina 22.

IMPIANTI E CIRCUITI - SERBATOIO E ACCESSORI

IV-1-2- Filtro separatore acqua/benzina

NOTA:	Per proteggere il motore, sul circuito d'alimentazione della benzina si trova un filtro separatore acqua/benzina.
--------------	--

Questo filtro si trova nel gavone di poppa, sulla parete a tribordo:

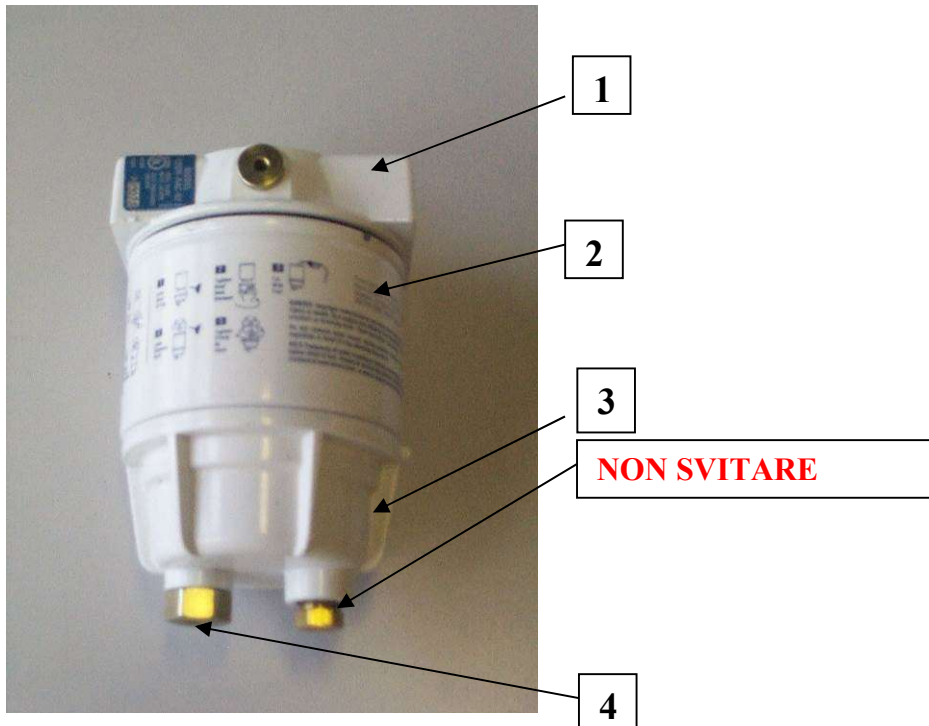

RIF.	DESCRIZIONE
1	Testa del filtro, fissata all'imbarcazione
2	Elemento di filtrazione intercambiabile
3	Recipiente metallico
4	Vite di spurgo

 AVVERTENZA	Non svitare la vite piccola: ciò potrebbe danneggiare la guarnizione e alterare l'impermeabilizzazione del recipiente.
-----------------------	---

NOTA	Durante l'uso, verificare l'assenza d'acqua nel recipiente metallico: Svitare leggermente il tappo di scarico (senza toglierlo completamente); svuotare l'acqua; riavvitare il tappo se nel recipiente c'è solo benzina. Ripetere l'operazione più spesso se il motore non funziona correttamente.
-------------	---

IMPIANTI E CIRCUITI - SERBATOIO E ACCESSORI

 AVVERTENZA	<p>È indispensabile spurgare e pulire regolarmente il filtro e sostituire la cartuccia almeno una volta l'anno. Il recipiente metallico è riutilizzabile.</p>
--	--

Sostituzione della cartuccia del filtro:

Attenersi alle raccomandazioni ZODIAC e a quelle del costruttore del filtro.

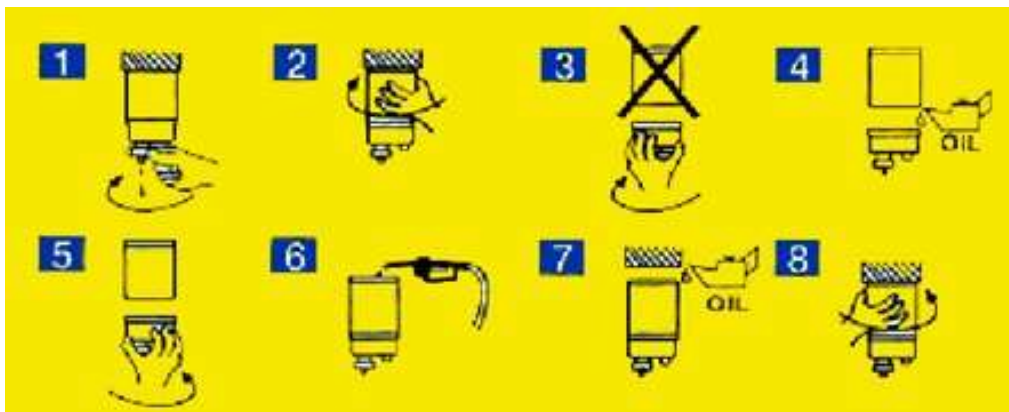

IV-1-3- Raccomandazioni:

 AVVERTENZA	<ul style="list-style-type: none"> <input checked="" type="checkbox"/> Il serbatoio pieno evita la condensa a ogni uscita. <input checked="" type="checkbox"/> Pulire il serbatoio ogni 5 anni. <input checked="" type="checkbox"/> Verificare il serraggio delle fascette su tutti i tubi flessibili. <input checked="" type="checkbox"/> Durante lo spurgo del filtro, non svuotare l'acqua nell'imbarcazione. Usare una vaschetta di recupero sotto il filtro. <input checked="" type="checkbox"/> Spegnerne il motore prima di smontare la cartuccia del filtro. <input checked="" type="checkbox"/> Leggere attentamente le istruzioni riportate sul manuale del filtro.
--	---

 AVVERTENZA	<ul style="list-style-type: none"> <input checked="" type="checkbox"/> La benzina è estremamente infiammabile. Qualora si debba intervenire sul sistema del carburante, assicurarsi che i motori siano spenti. Non fumare; allontanare qualsiasi fiamma o corpo incandescente dall'area di lavoro.
--	--

IMPIANTI E CIRCUITI - ELETTRICITÀ

IV-2- SCHEMA ELETTRICO

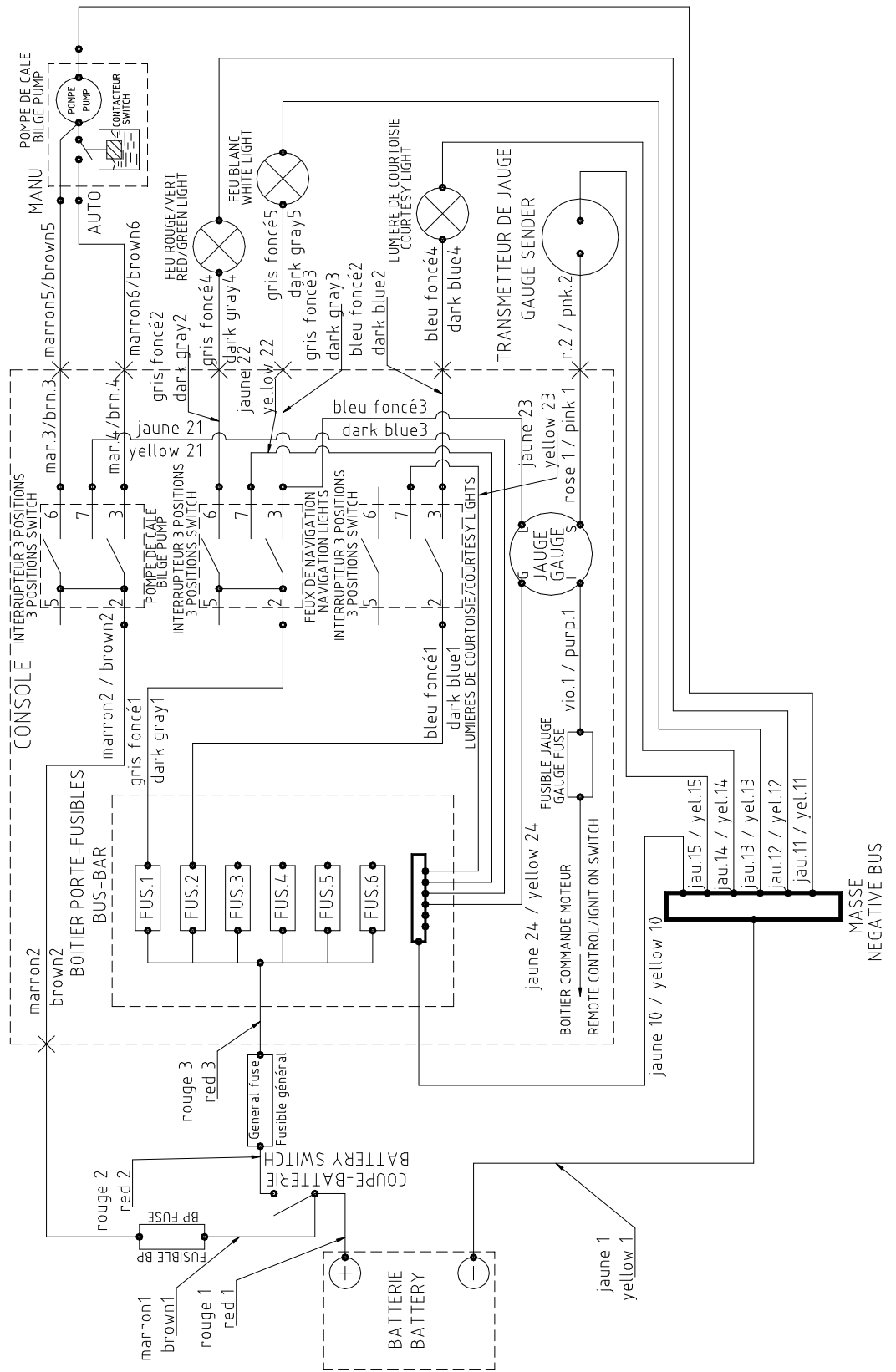



IMPIANTI E CIRCUITI - ALLACCIAMENTO DEGLI OPTIONAL

IV-3- BATTERIA (non fornita)

Attenersi alle raccomandazioni Zodiac e a quelle del costruttore delle batterie per la manutenzione corrente.

	<p>Effettuare la manutenzione della batteria:</p> <ul style="list-style-type: none"> <input checked="" type="checkbox"/> Mantenere la batteria pulita e asciutta per evitarne l'usura prematura. <input checked="" type="checkbox"/> Riserrare ed effettuare la manutenzione dei capicorda sul morsetto, lubrificandoli regolarmente.
---	--

 ATTENZIONE	<p>L'acqua proveniente dal sistema d'immissione dell'acqua contiene minerali dannosi per le batterie. Provvedere pertanto al rabbocco con sola acqua distillata.</p>
 AVVERTENZA	<ul style="list-style-type: none"> • Tenere le batterie e l'elettrolita fuori dalla portata dei bambini • Non capovolgere mai la batteria. • Durante il rabbocco dell'elettrolita o la ricarica della batteria, estrarla sempre dal comparto motore. • L'elettrolita è un liquido tossico e pericoloso. Contiene acido solforico che può provocare ustioni gravi. Evitare qualsiasi contatto con la cute, gli occhi e gli indumenti. • Le batterie possono sprigionare gas esplosivi. Allontanare qualsiasi fonte di scintille, fiamme libere, sigarette ecc. • Durante la ricarica o l'uso della batteria, intervenire in un luogo ben aerato. Proteggere sempre gli occhi durante qualsiasi intervento nei pressi della batteria.

NOTA:	<ul style="list-style-type: none"> <input checked="" type="checkbox"/> Qualora l'imbarcazione Zodiac non venga utilizzata per un mese o più, estrarre la batteria e riporla in un luogo fresco, al riparo dalla luce e asciutto. Ricaricare completamente la batteria prima di riutilizzarla <input checked="" type="checkbox"/> Qualora la batteria debba essere stoccata per un periodo più lungo, verificare la densità dell'elettrolita almeno una volta al mese e ricaricare la batteria non appena la densità risulti troppo bassa. <p>Densità dell'elettrolita: 1,28 a 20°C</p>
--------------	---

NOTA:	<p>Quando non si utilizza l'imbarcazione, spostare l'interruttore di sicurezza su OFF.</p>
--------------	---

IMPIANTI E CIRCUITI - Allacciamento degli optional

IV-4- RIMESSAGGIO DELL'ALBERO PER LUCI DI NAVIGAZIONE



AVVERTENZA

Per evitare di danneggiare l'albero per luci di navigazione alla chiusura della seduta, assicurarsi di fissarlo come indicato nella foto qui sopra.

NOTA

Per facilitare lo stoccaggio dell'albero nei suoi blocchetti di fissaggio, è possibile applicare acqua insaponata.

VISTA DALL'ALTO:

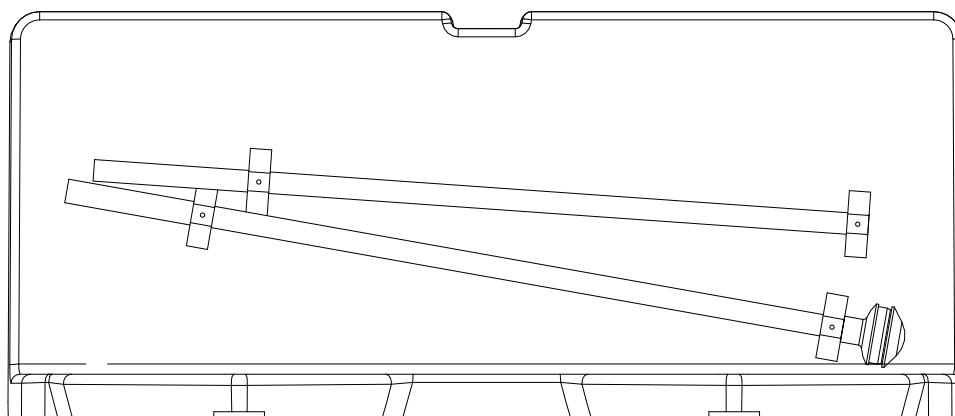

IMPIANTI E CIRCUITI - Allacciamento degli optional

IV-5- ALLACCIAMENTO DEGLI OPTIONAL

IV-5-1- Precauzioni:

L'imbarcazione è dotata di serie di una pompa di sentina, di luci di navigazione e di illuminazione della coperta. Tuttavia, restano disponibili 4 posizioni nella scatola di fusibili (sotto la consolle) per l'allacciamento di accessori supplementari, a determinate condizioni:

- ① Gli accessori da aggiungere devono essere allacciati a livello della consolle.
- ② Gli accessori si dividono in due categorie:
 - A** → gli accessori che vengono utilizzati o che sono suscettibili di essere utilizzati di continuo assieme all'uso normale dell'imbarcazione,
 - B** → gli accessori utilizzati in modo saltuario.

A	
Ventilatore di sentina	
Radio	
Scandaglio	
GPS	
Riflettore	
Sistema d'allarme	
Frigorifero	
VHF	
Σ	180 W max

B	
Presse accendisigari	
Luci varie	
Segnale acustico	
Apparecchi elettronici vari	
Pompa doccia	
Potenza massima	72 W max

 AVVERTENZA	<p>Accertarsi tassativamente che la potenza complessiva degli accessori <u>aggiunti</u> della colonna A sia inferiore o uguale a 180 W (15 A) E che la potenza massima di un accessorio della colonna B sia inferiore o uguale a 72 W (6 A).</p> <p>Le sezioni dei diversi cavi del fascio sono state calcolate in base a questi valori; il mancato rispetto di questa regola può provocare guasti elettrici e cortocircuiti.</p>
--	---

NOTA:	<p>Se si fanno installare numerosi equipaggiamenti elettrici, il consumo provvisorio totale potrà eventualmente eccedere la capacità di carica del motore fuori bordo. Ad esempio, il fascio elettrico può supportare un consumo provvisorio di 285 W (luci di navigazione e pompa di sentina inclusi), vale a dire leggermente inferiore ai 24 A in termini di alimentazione elettrica. Gli attuali alternatori del motore forniscono di norma un'intensità di 15 A a pieno regime (verificare questo dato nella documentazione tecnica del motore). È dunque opportuno evitare un uso prolungato di tali apparecchi, onde prevenire un consumo eccessivo della batteria con il conseguente rischio di non poter riavviare il motore.</p>
--------------	---

IMPIANTI E CIRCUITI - ALLACCIAMENTO DEGLI OPTIONAL

Esempio 1

Si desidera aggiungere:

Un VHF da 72 W,

Un GPS da 36 W,

Una radio da 60 W,

Un accendisigari da 72 W,

Un orologio da 20 W.

A	
Ventilatore di sentina	
Radio	60 W
Scandaglio	
GPS	36 W
Riflettore	
Sistema d'allarme	
Frigorifero	
VHF	72 W
Σ	168 W (<180 W) 

e

B	
Luci varie	
Apparecchi elettronici vari	20 W (orologio)
Pompa doccia	
Potenza massima	20 W (< 72 W) 

CONCLUSIONE



Esempio 2

Si desidera aggiungere:

Un VHF da 60 W,

Un GPS da 36 W,

Una radio da 48 W,

Un riflettore da 120 W.

A	
Ventilatore di sentina	
Radio	48 W
Scandaglio	
GPS	36 W
Riflettore	120 W
Sistema d'allarme	
Frigorifero	
VHF	60 W
Σ	264 W (> 180 W) 

e

B	
Luci varie	
Apparecchi elettronici vari	
Pompa doccia	
Potenza massima	0 (< 72 W) 

CONCLUSIONE



IMPIANTI E CIRCUITI - ALLACCIAMENTO DEGLI OPTIONAL

Esempio 3

Si desidera aggiungere:

Un GPS da 60 W,

Una radio da 60 W,

Un segnale acustico da 120 W.

A	
Ventilatore di sentina	
Radio	60 W
Scandaglio	
GPS	60 W
Riflettore	
Sistema d'allarme	
Frigorifero	
VHF	
Σ	120 W (< 180 W) ↻

e

B	
Luci varie	
Apparecchi elettronici vari	120 W
Pompa doccia	
Potenza massima	120 W (> 72 W) ⚡

CONCLUSIONE	
-------------	--

NOTA	Alcuni costruttori forniscono l'amperaggio invece della potenza assorbita. In corrente continua con una batteria da 12 V (come in questo caso), è sufficiente moltiplicare per 12 per ottenere la potenza.
-------------	---

IV-5-2- Cablaggio:

- ① Scegliere una posizione con un fusibile libero,
- ② Collegare il cavo d'alimentazione del proprio accessorio al morsetto corrispondente a questa posizione usando un "capocorda a linguetta" (tipo faston) femmina da 6mm.
- ③ Se è necessario aggiungere del cavo per il collegamento, utilizzare un cavo di sezione minima 1,5mm² rispettando le raccomandazioni per i cavi di tipo "marino" (UL1426 o SAE J378 o SAE J1127 o SAE J1128 o, in generale, ABYC e/o CE).
- ④ Collegare il cavo di massa dell'accessorio al blocco morsetti di massa con un "capocorda a occhiello" Ø 5 (stessa raccomandazione relativa ai cavi).
- ⑤ Inserire un fusibile tipo ATO da 15A max e superiore all'intensità d'uso dell'apparecchio.

IV-5-3- Allacciamento livello benzina:

Eseguire l'allacciamento seguendo le indicazioni dello schema (pagina 19).

IMPIANTI E CIRCUITI - ALLACCIAMENTO DEGLI OPTIONAL

IV-5-4- Installazione degli accessori sulla consolle:

In funzione del livello di equipaggiamento dell'imbarcazione, ZODIAC raccomanda la seguente disposizione (vedere sagome di foratura fornite con l'imbarcazione) che ottimizza lo spazio disponibile.

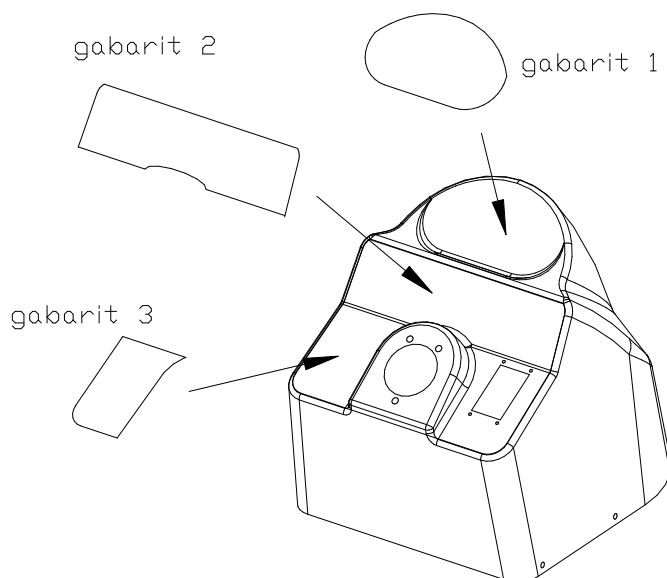

IV-6- FUNZIONAMENTO DELLA POMPA DI SENTINA

Il funzionamento della pompa di sentina è indipendente dalla posizione dell'interruttore di batteria: l'interruttore di comando  è sempre sotto tensione.

- ① Funzionamento automatico (posizione fissa): in questa posizione, il funzionamento della pompa di sentina è automatico. La spia è accesa.
- ② Arresto: in questa posizione (fissa), la pompa di sentina non funziona. La spia è spenta.
- ③ Funzionamento forzato: l'interruttore deve essere mantenuto premuto per un funzionamento forzato. Non appena si rilascia il dito, l'interruttore ritorna sulla posizione di arresto (2).

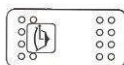

Durante l'ormeggio, mettere l'interruttore della pompa di sentina sulla posizione di funzionamento automatico.

NOTA

Zodiac raccomanda l'uso di un telone o di una cappa di ormeggio per evitare d'imbarcare acqua in caso di pioggia.

**AVVERTENZA**

Si attira l'attenzione sul processo di finitura in cui alcuni elementi strutturali, come le consolle dello sterzo, i sedili e le sovrastrutture, sono installati da parti terze diverse dal fabbricante dell'imbarcazione. È opportuno che questi elementi siano installati in modo da essere conformi ai requisiti pertinenti di ISO 6185-3 al fine di garantire che tutti questi impianti non invalidino la valutazione iniziale.

Assicurarsi anche che l'installazione posteriore delle consolle e degli altri elementi strutturali non inizialmente forniti con l'imbarcazione sia realizzata conformemente ai consigli di installazione forniti dal costruttore e alle raccomandazioni di ZODIAC.



ZNAUTIC GROUP
2 chemin de la Val Priout
31450 AYGUESVIVES
FRANCE

YACHTLINE 360-400



Teil 2

***YACHTLINE
360 / 400***

611133 A



LESEN SIE DIESES HANDBUCH VOR DER INBETRIEBNAHME IHRES ZODIAC AUFMERKSAM DURCH

BAND 2

BESCHREIBUNG - TRAGSCHLAUCH ANTRIEBSSYSTEM ANLAGEN UND KREISLÄUFE

INHALT

	SEITE
⇒ I - ALLGEMEINE BESCHREIBUNG	
I-1-Technische Daten -----	2 - 3
I-2-Bestandteile-----	4 - 5
I-3-Anordnung der Elemente-----	6 - 7
I-4-Handhabung-----	8 - 10
⇒ II - TRAGSCHLAUCH	
II-1-Wichtigste Schritte bei der Inbetriebnahme des Tragschlauchs -----	11
II-2-Montage des Tragschlauchs auf den Rumpf-----	12 - 13





II-3-Aufpumpsystem-----	14
II-4-Druck-----	14 - 16
⇒ III - ANTRIEBSSYSTEM	17
⇒ IV - ANLAGEN UND KREISLÄUFE	
IV-1-Kraftstoffanlage -----	18 - 20
IV-2-Elektrischer Schaltplan-----	21

IV-3-Batterie-----	22
IV-4-Lagerung des Masts für Positionsleuchten-----	23
IV-5-Anschluss von Zusatzgeräten-----	24 - 26

IV-6-Funktionsweise der Bilgepumpe-----	27



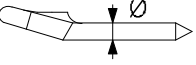

BESCHREIBUNG - TECHNISCHE DATEN

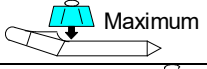
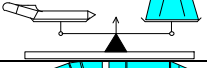
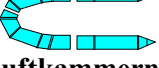

I-1 TECHNISCHE DATEN

Abmessungen			
		YL 360	YL 400
	(m)	3.60	4.00
	(ft)	11' 8"	13' 1"
	(m)	2	2.40
	(ft)	6' 7"	7' 10"
	(m)	1.77	1.77
	(ft)	5' 10"	5' 10"
	(m)	0.86	0.86
	(ft)	2' 10"	2' 10"
	(m)	0.455	0.455
	(ft)	1' 6"	1' 6"

Zertifizierung	
 (Richtlinie 94/25/EG)	C

Ladefähigkeit			
		YL 360	YL 400
 (ISO)		4	5
	kg ⁽¹⁾	605	735
	lb ⁽¹⁾	1.334	1.621
	kg ⁽²⁾	200	218
	lb ⁽²⁾	441	481
 Luftkammern		3	3

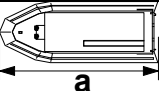
Motorisierung				
		YL 360	YL 400	
	Empfohlene MINDESTLEISTUNG	PS ⁽³⁾	15	20
		kW ⁽³⁾	12	15
	Empfohlene HÖCHSTLEISTUNG	PS	40	50
		kW	30	23
	Zulässige HÖCHSTLEISTUNG	PS ⁽³⁾	40	50
		kW ⁽³⁾	30	37
	Motor HÖCHSTGEWICHT	kg	119	119
		lb	262	262

Abmessungen			
		YL 360	YL 400
	a ⁽⁴⁾	3.18 m	3.58 m
		10' 5"	11' 9"
	b ⁽⁴⁾	1.40 m	1.40 m
		4'6"	4'6"
	c ⁽⁴⁾	0.98 m	0.98 m
		3' 2"	3' 2"

BESCHREIBUNG - TECHNISCHE DATEN

HINWEIS	Maßtoleranzen: +/- 4 %
----------------	-------------------------------

HINWEIS	<p>⁽¹⁾ Das zulässige Höchstgewicht wurde gemäß Norm ISO 6185 berechnet. Fahrten mit oder knapp an der zulässigen Nutzlast sind nur in ruhigem Gewässer und mit reduzierter Geschwindigkeit empfehlenswert.</p> <p>⁽²⁾ Gewichtsangaben ohne Zubehör</p> <p>⁽³⁾ Die empfohlenen Leistungen sind auf optimale Ausnutzung der Bootskapazitäten bei mittlerer Last abgestimmt. (4 Personen).</p> <p>⁽⁴⁾ Rumpfabmessungen ohne Tragschlauch.</p> <p>Nutzen Sie die zulässige Höchstleistung mit größter Vorsicht (siehe Eignerhandbuch Band I Kapitel „Empfehlungen für die Navigation“).</p>
----------------	---

 ACHTUNG	<p>Das auf dem HERSTELLERSCHILD angegebene Höchstgewicht darf nicht überschritten werden. Das Höchstgewicht beinhaltet das Gewicht von Motor, Kraftstoff, Zusatzgeräten, Besatzung und Passagieren einschließlich deren Ausrüstung sowie JEDE andere ZULADUNG.</p>
--	---

 ACHTUNG	<p>KEINE ENTZÜNDBAREN PRODUKTE IM HINTEREN STAURAUM LAGERN. DIE LAGERUNG EINES NACHFÜLLTANKS IST AUSDRÜCKLICH VERBOTEN..</p>
---	---

NUR FÜR 400 DL:

 WARNUNG	<p>EINGESCHRÄNKTE MANÖVRIERFÄHIGKEIT BEI FAHRT ÜBER 25 KNOTEN.</p> <p>Bei zu engen Kurven kann das Boot außer Kontrolle geraten. Vor einem Richtungswechsel die Geschwindigkeit drosseln.</p> <p>(* SIE KÖNNEN AUCH DEN POWER TRIMM BETÄTIGEN UND DEN MOTOR ZUM HECK HIN KIPPEN.</p>
---	--

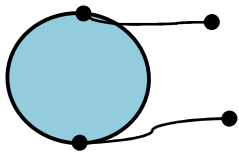
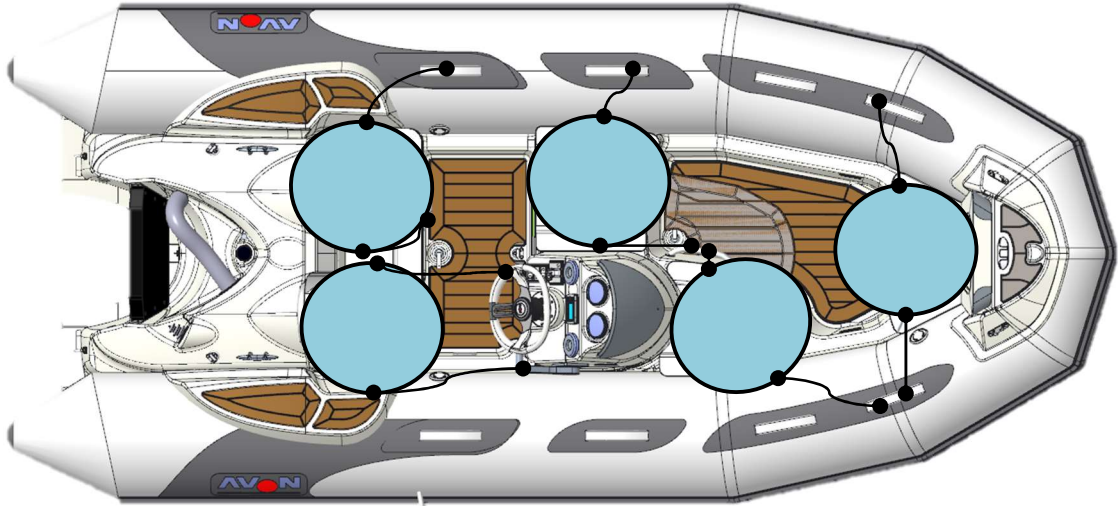

Sitzplatz mit Handgriffen für Yachtline 400

BESCHREIBUNG - STÜCKLISTE

I-2-STÜCKLISTE

RUMPF
• Polyesterrumpf
• rutschfestes eingeformtes Deck
• Eingesetzter Heckspiegel und Unterwasserrumpf mit Trimmklappen
• Steuerstand mit Staufach
• 1 Bugring
• 1 Ankerkasten + Staukasten vor dem Steuerstand (nur bei 400 YL)
• 1 Staukasten im Heck
• 4 Sitze mit Polstern bei YL 360 (5 Sitze bei 400 YL)
• 2 Heckbelegklampen
• 1 Trittstufe aus Polyester im Bug mit Belegklampe, Positionsleuchten und LEDs
• 1 klappbarer und abnehmbarer Mast für Topplicht
• 1 Deckbeleuchtung
• 3 gelenkige Hubringe
• 2 Schleppringe
• 2 Schnelllenzventile + 1 Rumpflenzventil

TRAGSCHLAUCH
• Abnehmbarer Tragschlauch
• Neopren Hypalon 1100 Decitex-Gewebe
• Easy-Push-Ventile
• Scheuerschutzband mit breitem Profil
• 6 Griffe
• Kegelerstärkungen

STEUERSTAND
• Steuerrad und Fernschaltung
• 3 Schalter
• Handschuhfach

BESCHREIBUNG - STÜCKLISTE

STANDARD AUSSTATTUNG
• 1 fest eingebauter Kraftstofftank (35 Liter + Geber für Kraftstoffanzeige + Benzinflter/Wasserabscheider) mit Belüftung und Überlaufschutzvorrichtung
• Positionsleuchten und Deckbeleuchtung
• 1 Batteriekasten
• 1 Batterieschalter
• Vorverkabelung für zusätzliches Zubehör
• 1 Bilgepumpe
• 2 Paddel
• 1 Fußluftpumpe
• 1 Reparaturkoffer
• 1 Eignerhandbuch (2 Bände)
• 1 Manometerverschluss

OPTIONAL ERHÄLTliches ZUBEHÖR
• Hebestropp-Set
• Badeleiter
• Hintere Rückenlehne
• Deck aus Teak-Laminat
• Windabweiser

BESCHREIBUNG – ANORDNUNG DER ELEMENTE

I-3-ANORDNUNG DER ELEMENTE

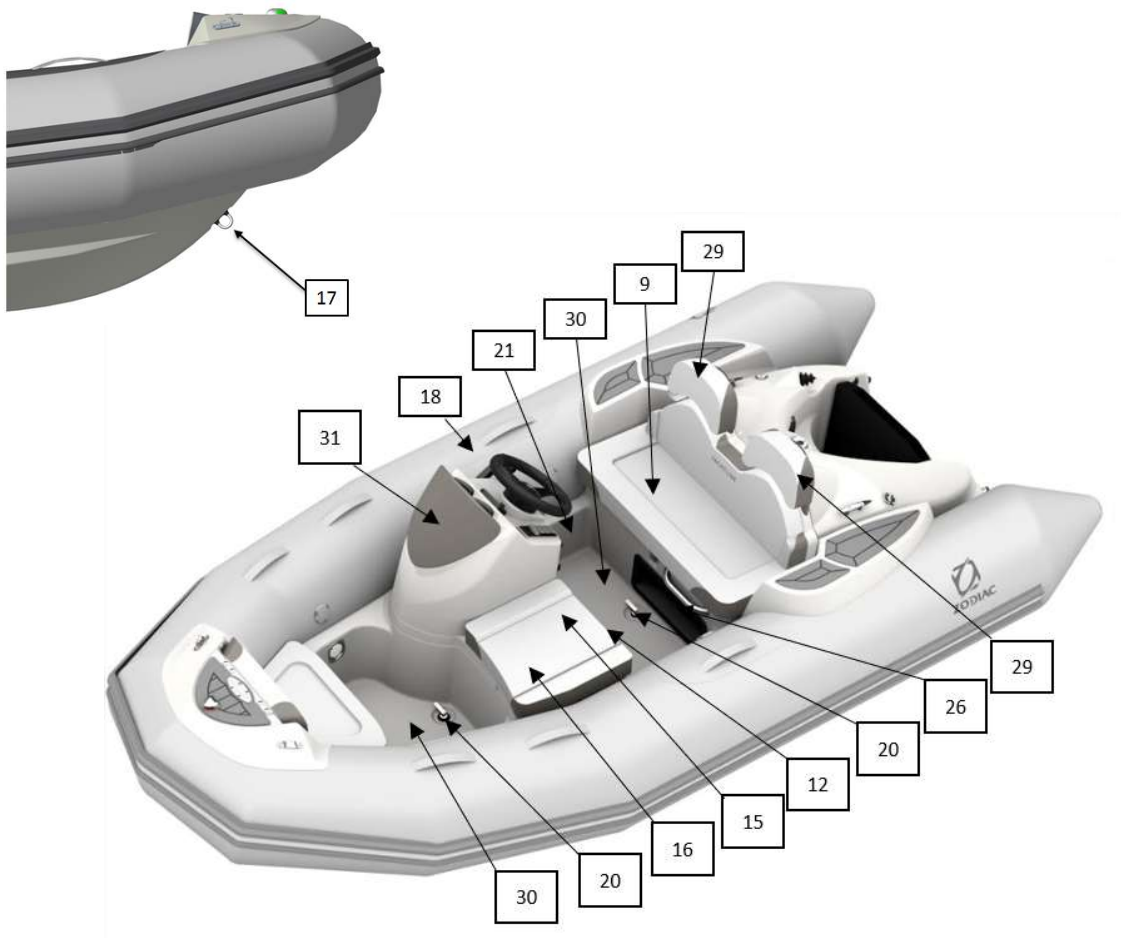
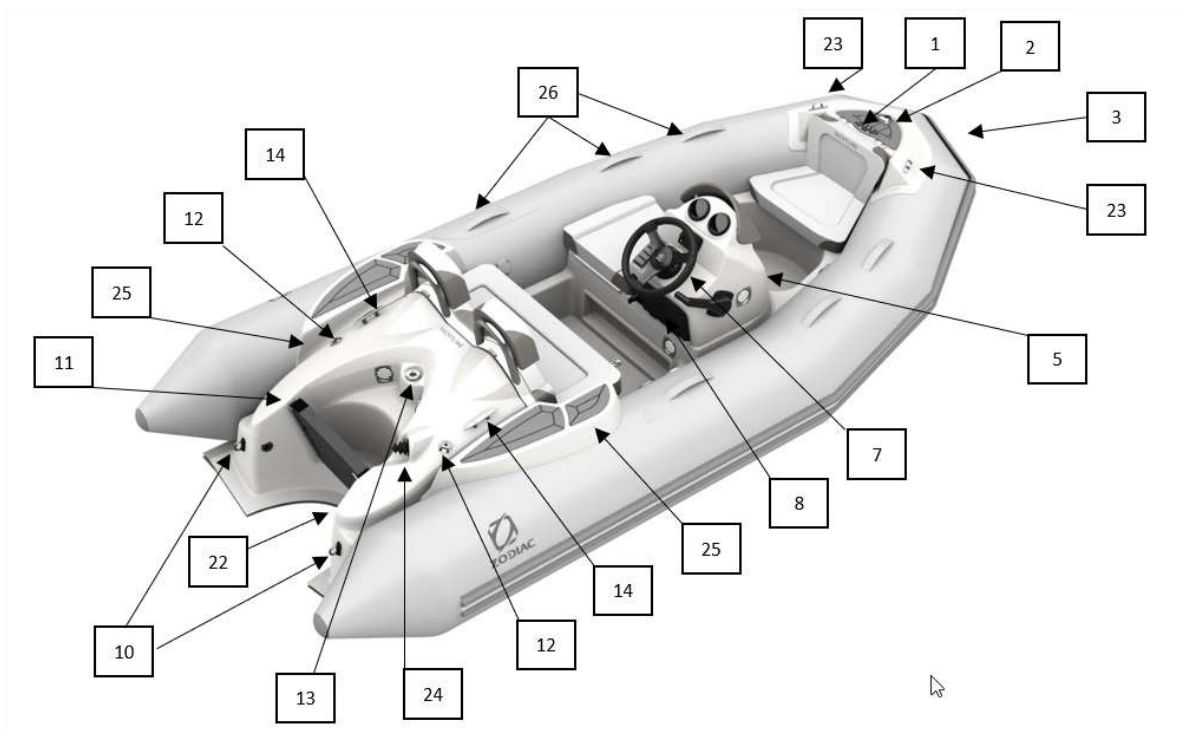

BESCHREIBUNG – ANORDNUNG DER ELEMENTE

POS.	BEZEICHNUNG
1	Bugbelegklampe
2	Positionsleuchten
3	Trittstufe aus Polyester im Bug
4	Ankerkasten
5	Steuerstand
6	Schalter
7	Steuerrad
8	Handschuhfach
9	Sitz mit umklappbarer Rücklehne im Heck
10	Schleppringe/Festmacherringe
11	Heckspiegel
12	Hubringe
13	Halterung des Topplichtmasts
14	Heckbelegklampen
15	Tankbefüllsystem
16	Zugangsklappe für Tankwartung
17	Bugring
18	Tragschlauch
19	Feuerlöscherhalterung
20	Schnellenzventile
21	Deckbeleuchtung
22	Rumpflenzventil
23	Lippklampe
24	Kabeldurchführung
25	Trittstufe aus Polyester
26	Griff
27	Easy-Push-Ventile
28	Zigarettenanzünderbuchse 12 V
29	Hintere Rückenlehne
30	Deck aus Teak-Laminat
31	Windabweiser

BESCHREIBUNG - Handhabung

I-4 HANDHABUNG

I-4-1-Transport:

- Hinweise zum Transport auf einem Anhänger finden Sie im Eignerhandbuch BAND I.

I-4-2-Lagerung:

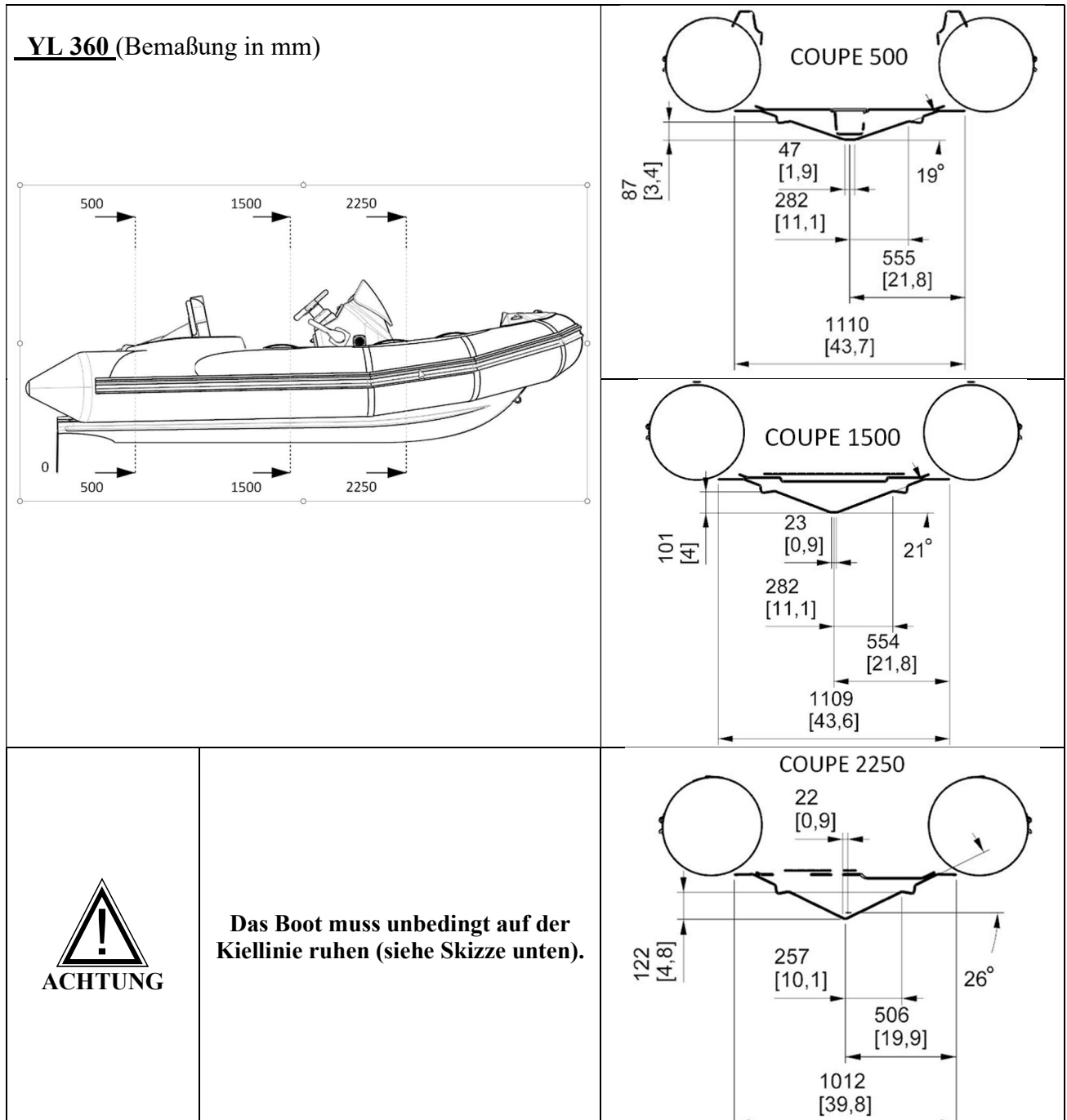

YL 400 (Bemaßung in mm)

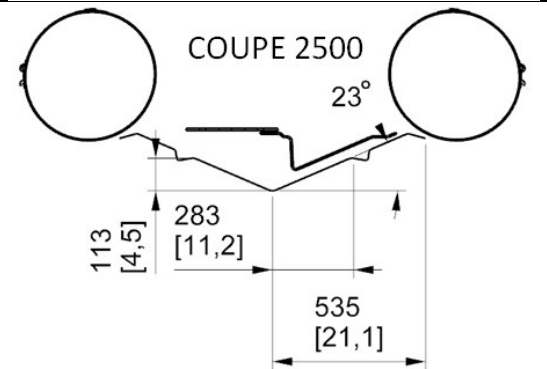
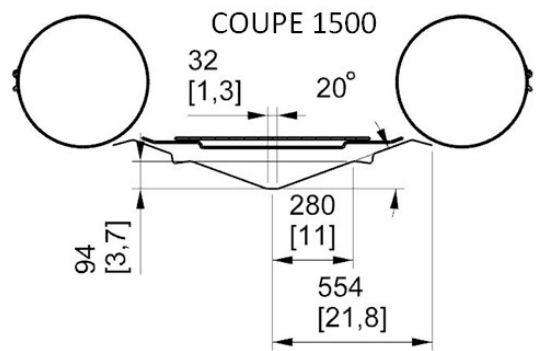
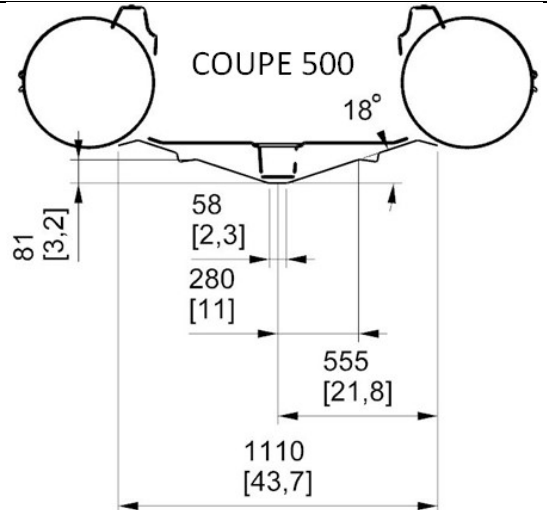
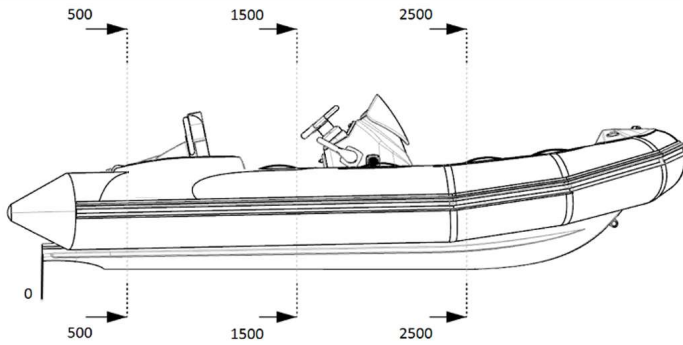

Das Boot muss unbedingt auf der Kiellinie ruhen (siehe Skizze unten).

BESCHREIBUNG - Handhabung

I-4-3-Heben

 WARNUNG	<p>Der Stropp ist als Zubehör erhältlich; zum Anheben darf ausschliesslich ein AVON Stropp verwendet werden.</p>
---	--

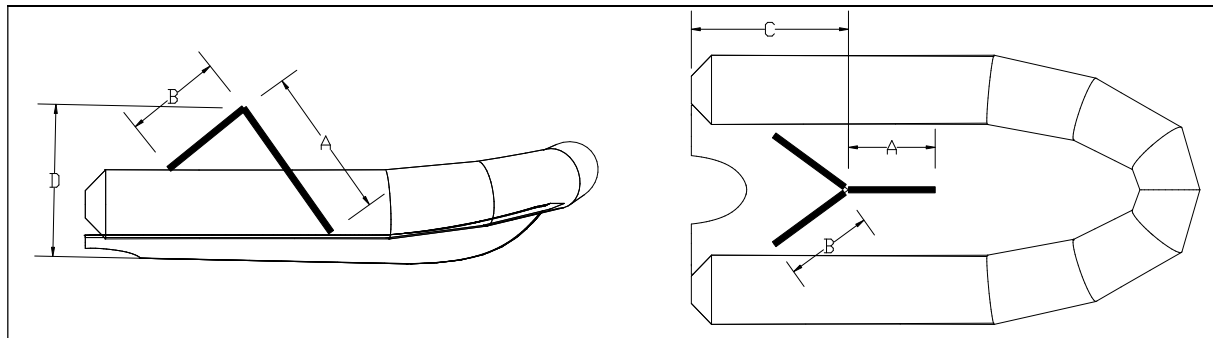

Alle Angaben sind Richtwerte		A	B	C	D
360 YL	(m)	1.25	1	1.45	1.4
	(ft)	4'1''	3'3''	4'8''	4'6''
400 YL	(m)	1.25	1	1.45	1.4
	(ft)	4'1''	3'3''	4'8''	4'6''

 WARNUNG	<p>WÄHREND DES HIEV-VORGANGS DARF NIEMAND AN BORD SEIN.</p>
---	---

 VORSICHT	<ul style="list-style-type: none"> • Beim Heben bzw. Davitaufhängen MUSS das Boot KOMPLETT AUSGELADEN sein. • Die SCHNELLENZVENTILE ZUM LENZEN DES DECKS (Pos. 20*) und das Rumpflenzventil (Pos. 22*) müssen geöffnet werden, so dass eventuell im Cockpit angesammeltes Regenwasser ablaufen kann. <p>* siehe Kapitel I-3 „Anordnung der Elemente“</p>
--	--

TRAGSCHLAUCH – INBETRIEBNAHME

II-1-WICHTIGSTE SCHRITTE BEI DER INBETRIEBNAHME DES TRAGSCHLAUCHS

Das Boot muss in einer bestimmten Reihenfolge montiert werden. Wir empfehlen Ihnen, sich an diese Reihenfolge zu halten. Gehen Sie Schritt für Schritt vor und lesen Sie die Erklärungen zur Vorgehensweise auf den entsprechenden Seiten aufmerksam durch.

VERFAHREN	SEITE	ABSCHNITT
1. Prüfen Sie die Bestandteile Ihres Bootes auf Vollständigkeit und machen Sie sich mit den einzelnen Teilen vertraut	4-5	Überprüfung beim Auspacken
	6-7	Anordnung der Elemente
2. Montieren Sie den Tragschlauch auf dem Rumpf	11	Montage des Tragschlauchs
3. Befestigen Sie die innere Dichtlippe	12	Befestigung der Dichtlippe
4. Positionieren Sie die äußere Dichtlippe		
5. Bringen Sie die Ventile in Pumpstellung	14	Aufpumpsystem
6. Pumpen Sie das Boot mit den Betriebsdruckwerten auf	15	Aufpumpen des Boots
	16-17	Luftdruck
7. Positionieren Sie die äußere Dichtlippe	12	Befestigung der Dichtlippe

TRAGSCHLAUCH – INBETRIEBNAHME

II-2 ANBRINGUNG DES TRAGSCHLAUCHS AM RUMPF



WENN DER TRAGSCHLAUCH BEI UNTER 0°C GELAGERT WURDE, BEWAHREN SIE IHN VOR DEM AUSEINANDERFALTEN 12 STUNDEN LANG AN EINEM ORT MIT RAUMTEMPERATUR (20 °C) AUF.

HINWEIS

Der Tragschlauch wird in **entleertem** Zustand auf den Rumpf montiert.

1

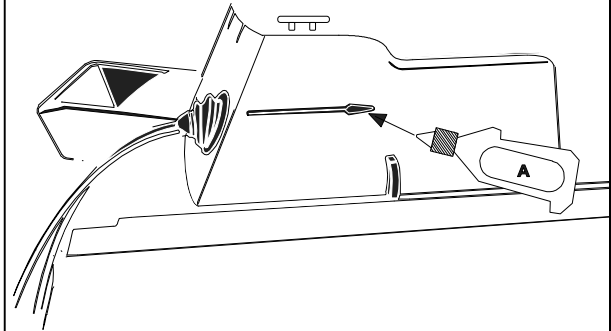
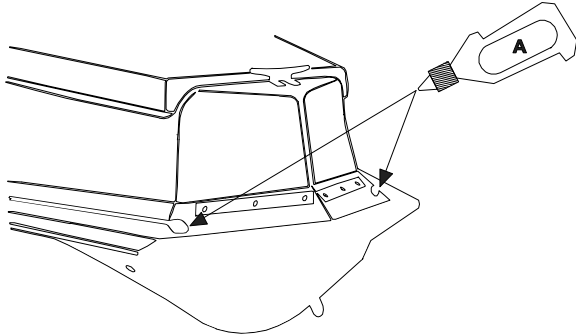

Beschmieren Sie die Rumpfschienen zur Erleichterung der Tragschlauchmontage mit Flüssigseife (A)

2

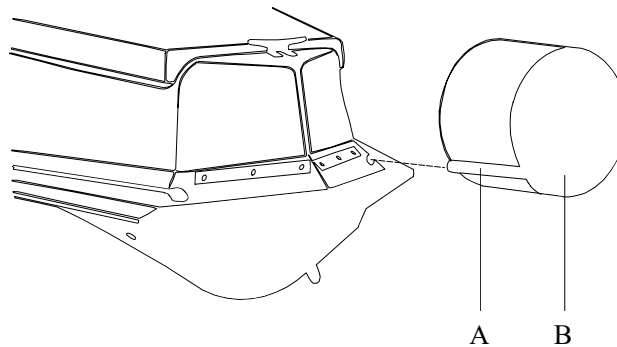

Setzen Sie den Tragschlauchkeder (a) (b) an der Rumpfschiene an.

3

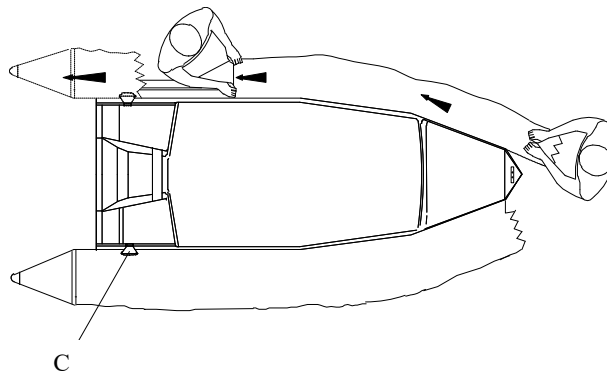

- Ziehen Sie den Tragschlauch zum Bootsheck hin (denken Sie daran, den oberen Keder (c) dabei zu führen).

- Verfahren Sie auf der anderen Seite des Tragschlauchs ebenso.

TRAGSCHLAUCH – INBETRIEBNAHME

4

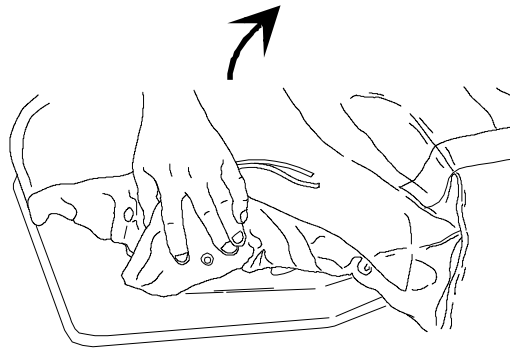

Setzen Sie die innere Dichtlippe ein

5

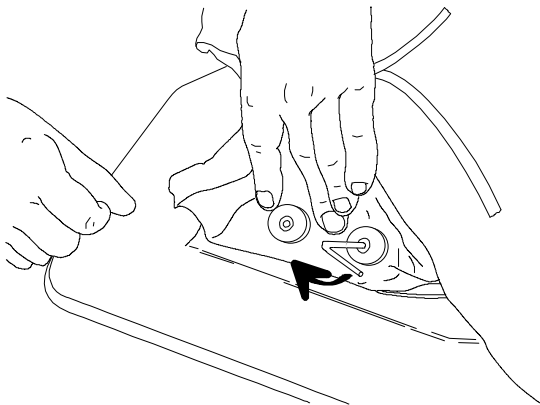

Befestigen Sie die innere Dichtlippe

6

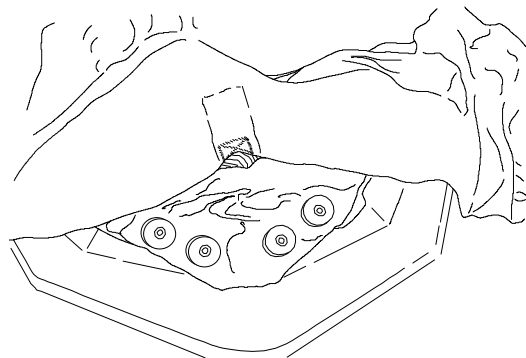

7

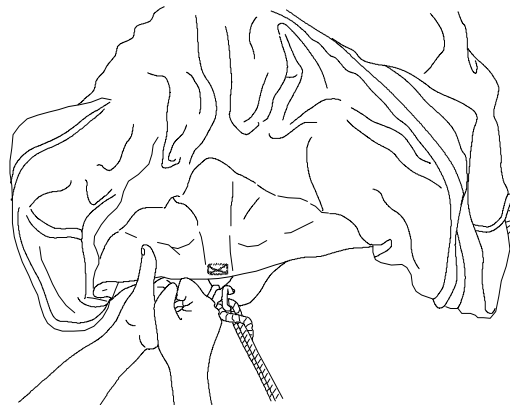

Nachdem die innere Dichtlippe am Rumpf befestigt wurde, ziehen Sie den Tragschlauch ein wenig nach vorne bis die äußere Dichtlippe über die Bugspitze hinaus steht (Dichtlippe noch nicht befestigen). Ziehen Sie dann den Tragschlauch nach hinten.

HINWEIS

Die endgültige Befestigung der externen Dichtlippe muss .
nach Aufpumpen des Tragschlauches erfolgen

ANSCHLIEßEND DEN TRAGSCHLAUCH AUFPUMPEN

TRAGSCHLAUCH - AUFPUMPSYSTEM

II-3-AUFPUMPSYSTEM

FUßPUMPE

- a. Adapter
- b. Schlauchspitze
- c. Schlauchanschluss
- d. Aufpumpöffnung

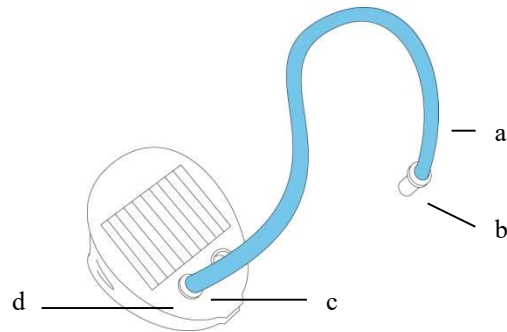

EASY-PUSH-VENTILE

Position ändern	Aufpumpstellung	Entleerungsstellung
<p>Drücken</p>	<p>Die Membran ist geschlossen, der Druckstift in oberer Position</p>	<p>Die Membran ist geöffnet, der Druckstift in unterer Position</p>

TRAGSCHLAUCH - LUFTDRUCK

AUFPUMPEN DES SCHLAUCHKÖRPERS

Bringen Sie alle Ventile in Aufpumpstellung.

Befestigen Sie den Schlauchanschluss am Aufpumpstutzen der Fußpumpe.
 Um Ihr Boot effizient aufpumpen zu können, muss die Fußpumpe stabil auf dem Boden liegen.
 Das Boot wird schneller aufgepumpt, wenn die Fußpumpe mit mäßigem Druck und ohne Hast betätigt wird.



Verwenden Sie keinen Kompressor bzw. keine Druckluftflasche.

TRAGSCHLAUCH - LUFTDRUCK

AUFPUMPEN DES SCHLAUCHKÖRPERS

- Setzen Sie den für den Durchmesser des halbversenkten Ventils passenden Adapter auf die Fußpumpenschlauchspitze.

Pumpen Sie die einzelnen Kammern des Tragschlauchs **gleichmäßig im Wechsel auf, bis die Schottwände (a) nicht mehr zu sehen sind (Druck = 240 mb)**

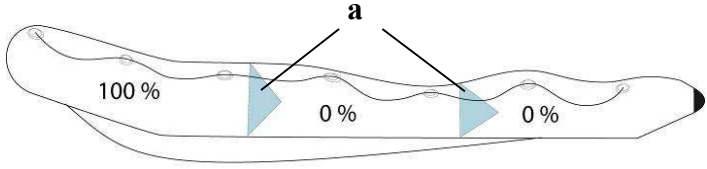
	Niemals eine Kammer voll aufpumpen, solange die anderen völlig leer sind	
---	--	--

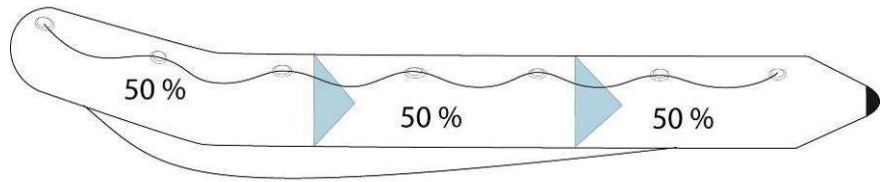
	1	
---	---	--

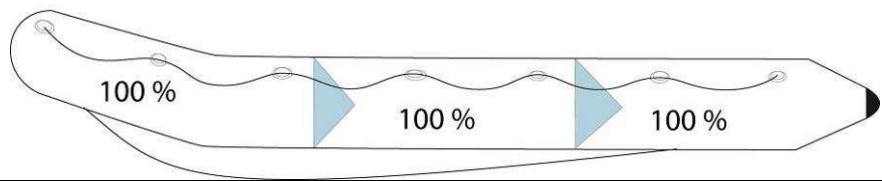
	2	
--	---	---

Wenn der Tragschlauch vollständig aufgepumpt ist: Schrauben Sie die Ventilverschlüsse auf.

HINWEIS:	Vor Aufschrauben der Ventilverschlüsse ist ein leichter Luftverlust normal. Erst die Verschlusskappen gewährleisten absolute Dichtheit.
-----------------	---

TRAGSCHLAUCH - LUFTDRUCK

BETRIEBSDRUCK

Der Betriebsdruck für den Tragschlauch beträgt 240 mb/ 3,4 PSI.

Die Luft- bzw. die Wassertemperatur	Umgebungstemperatur	Luftdruck im Schlauchkörper
wirkt sich proportional auf den Luftdruck im Tragschlauch aus:	+ 1 °C	+ 4 mb/+ 0,06 PSI
	- 1 °C	- 4 mb/- 0,06 PSI

Druckänderungen sind in der Regel vorhersehbar:
 Prüfen Sie den Druck in den Luftkammern und gleichen Sie (durch Nachpumpen bzw. Entleeren) die durch eventuelle Temperaturschwankungen entstandene Druckdifferenz aus (vor allem bei großen Temperaturdifferenzen zwischen Morgen- und Abendstunden in besonders warmen Klimazonen). Vergewissern Sie sich, dass der Druck innerhalb des empfohlenen Bereichs bleibt (220 bis 270 mb/grüner Bereich).

UNTERDRUCKGEFAHR:

Beispiel: Ihr Boot liegt am Stand in praller Sonne bei 50 °C, der Druck entspricht dem empfohlenen Luftdruck von 240 mbar/3,4 PSI. Wenn Sie das Boot zu Wasser lassen (Wassertemperatur 20 °C), sinkt die Temperatur und damit der Luftdruck in den Kammern um bis zu 120 mb ab. **SIE MÜSSEN ALSO NACHPUMPEN**, um den Druckverlust aufgrund des Temperaturunterschieds (zwischen Umgebungsluft und Wasser) auszugleichen. Wenn Sie also am Tagesende bei sinkenden Außentemperaturen einen Druckabfall feststellen, ist dies völlig normal.

ÜBERDRUCKGEFAHR:

Beispiel: Das Boot wird morgens oder abends mit dem empfohlenen Luftdruck (240 mbar/3,4 PSI) aufgepumpt (es herrschen Außentemperaturen von 10 °C). Im Laufe des Tages erwärmt sich das Boot bei einer Lufttemperatur von 50 °C in praller Sonne am Strand oder auf dem Deck Ihrer Yacht. Die Temperatur in den Kammern, insbesondere bei dunklen Tragschläuchen, steigt auf bis zu 70 °C, wobei sich der ursprüngliche Druck verdoppelt (auf 480 mb). **SIE MÜSSEN ALSO LUFT ABLASSEN**, um erneut den empfohlenen Druck zu erreichen.



Wenn Ihr Boot zu stark aufgepumpt ist, wird die Tragschlauchstruktur übermäßig belastet und die Kammern können durch den Überdruck an den Verbindungsstellen aufplatzen.

TRAGSCHLAUCH - LUFTDRUCK

BEI ÜBERDRUCK

Easy-Push-Ventile:
Drücken Sie auf den Ventildruckstift, um Luft entweichen zu lassen.

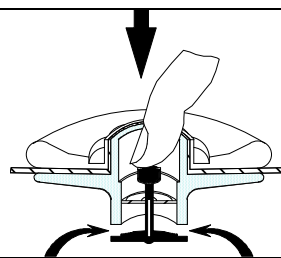

ANTRIEBSSYSTEM

III - Antriebssystem

Beachten Sie die von ZODIAC und vom Motorhersteller gegebenen Empfehlungen.

Zur optimalen Nutzung Ihres Boots lassen Sie sich von Ihrem Vertragshändler beraten.

ANLAGEN UND KREISLÄUFE – KRAFTSTOFFANLAGE

IV -1-Kraftstoffanlage

IV -1-1-Tank

Der Kraftstofftank befindet sich unter dem Steuerstand:

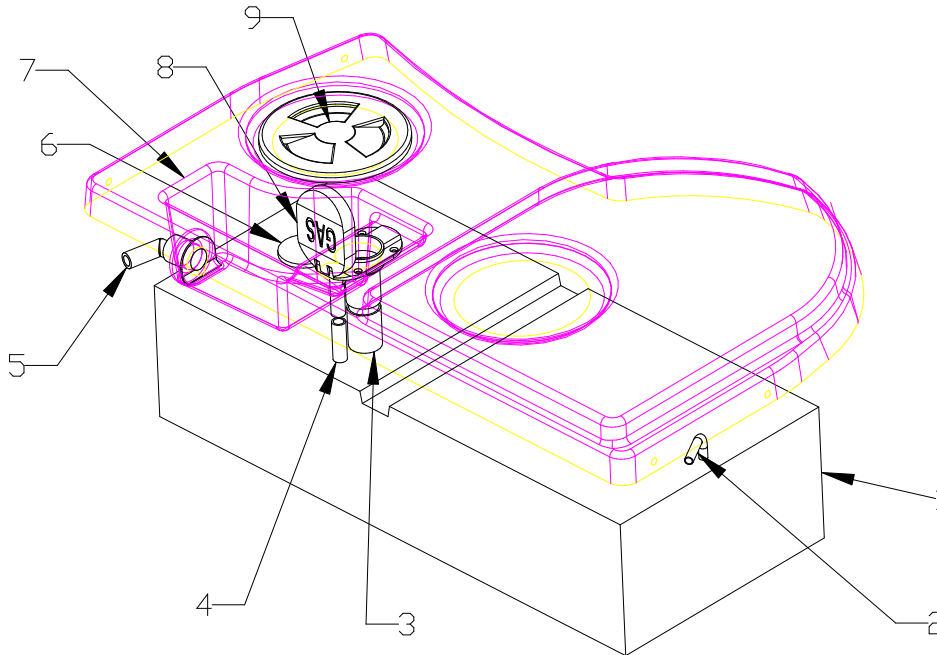

POS.	BEZEICHNUNG
1	Tank
2	Ausgang für Motorversorgung
3	Einfüllstutzen
4	Belüftungsöffnung
5	Lenzventil der „Überlaufwanne“
6	Tankgeber für Füllstandsanzeige
7	Überlaufwanne
8	Einfüllstutzen mit integrierter Belüftung
9	Tankwartungsklappe



ACHTUNG

ES MUSS ZWINGEND EINE FÜLLSTANDANZEIGE VORHANDEN SEIN. DIE FÜLLSTANDANZEIGE WIRD MIT DEM MOTOR GELIEFERT. SOLLTE KEIN ANZEIGEINSTRUMENT VORHANDEN SEIN, SETZEN SIE SICH MIT IHREM VERTRAGSHÄNDLER IN VERBINDUNG.

Die Sonde entspricht dem amerikanischen Standard:

Impedanz (Tank leer) 30 Ohm

Impedanz (Tank voll) 240 Ohm

Bis auf sehr wenige Ausnahmen sind alle marktgängigen Füllstandsanzeigen kompatibel.
Hinweise zum Anschluss finden Sie im Schaltbild Seite 22.

ANLAGEN UND KREISLÄUFE - Tank und Zubehör

IV-1-2--Benzinfilter/Wasserabscheider

HINWEIS:	Zum Schutz des Motors ist ein Wasser-/Benzinabscheider mit Filter im Kraftstoffsystem des Motors eingebaut.
-----------------	--

Der Benzinfilter/Wasserabscheider befindet sich steuerbordseitig im Heckstaukasten:

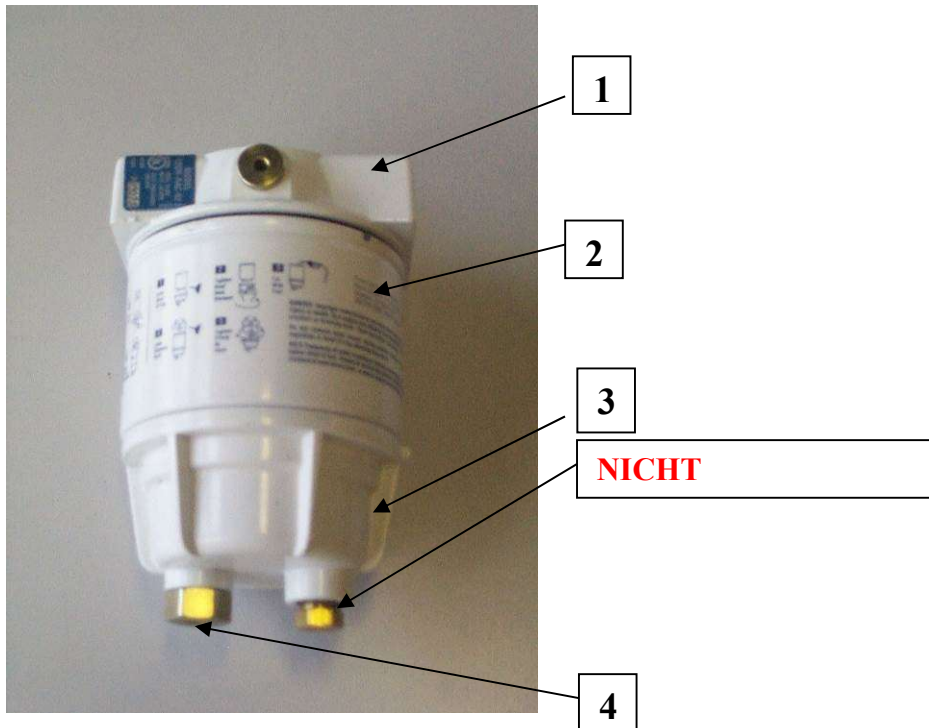

POS.	BEZEICHNUNG
1	Filterkopf, am Boot befestigt
2	Austauschbares Filterelement
3	Metallschale
4	Ablassschraube

 WARNUNG	<p>Die kleine Schraube nicht herausdrehen: Sie könnten die Dichtung beschädigen, so dass die Schale nicht mehr dicht ist.</p>
--------------------	--

HINWEIS	<p>Vor jedem Einsatz prüfen Sie, dass kein Wasser in der Metallschale vorhanden ist: Schrauben Sie die Ablassschraube ein wenig auf (nicht voll herausdrehen) und lassen Sie das Wasser ablaufen. Drehen Sie die Schraube wieder zu, sobald sich nur noch Benzin in der Schale sammelt. Wenn Ihr Motor nicht einwandfrei funktioniert, den Vorgang öfter wiederholen.</p>
----------------	--

ANLAGEN UND KREISLÄUFE - Tank und Zubehör

 WARNUNG	<p>Denken Sie daran, den Filter regelmäßig zu entleeren bzw. zu reinigen und die Filterpatrone mindestens einmal pro Jahr auszuwechseln.</p> <p>Die Metallschale ist wiederverwendbar.</p>
---	--

Austausch der Filterpatrone:

Beachten Sie die Empfehlungen von ZODIAC und dem Filterhersteller.



IV-1-3-Empfehlungen:

 WARNUNG	<ul style="list-style-type: none"> <input checked="" type="checkbox"/> Durch Auffüllen des Benzintanks vor jeder Fahrt kann Kondensation vermieden werden. <input checked="" type="checkbox"/> Lassen Sie den Benzintank alle 5 Jahre reinigen. <input checked="" type="checkbox"/> PRÜFEN SIE, OB DIE SCHELLEN AUF ALLEN GUMMISCHLÄUCHEN FEST SITZEN. <input checked="" type="checkbox"/> Wenn Sie den FILTER entleeren, lassen Sie das Wasser nicht ins Boot ab, sondern stellen Sie eine Auffangwanne unter den Filter. <input checked="" type="checkbox"/> Schalten Sie vor dem Ausbau der Filterpatrone die Zündung aus. <input checked="" type="checkbox"/> Lesen Sie die Anweisungen in der GEBRAUCHSANLEITUNG des Filters aufmerksam durch.
---	--

 WARNUNG	<ul style="list-style-type: none"> <input checked="" type="checkbox"/> Benzin ist hochentzündlich. FALLS SIE AN DER KRAFTSTOFFANLAGE ARBEITEN MÜSSEN, STELLEN SIE SICHER, DASS DIE MOTOREN ABGESCHALTET SIND. <input checked="" type="checkbox"/> NICHT RAUCHEN. Halten Sie Flammen und glühende Körper vom Arbeitsbereich fern.
---	--

ANLAGEN UND KREISLÄUFE – Elektrik

IV -2- ELEKTRISCHER SCHALTPLAN

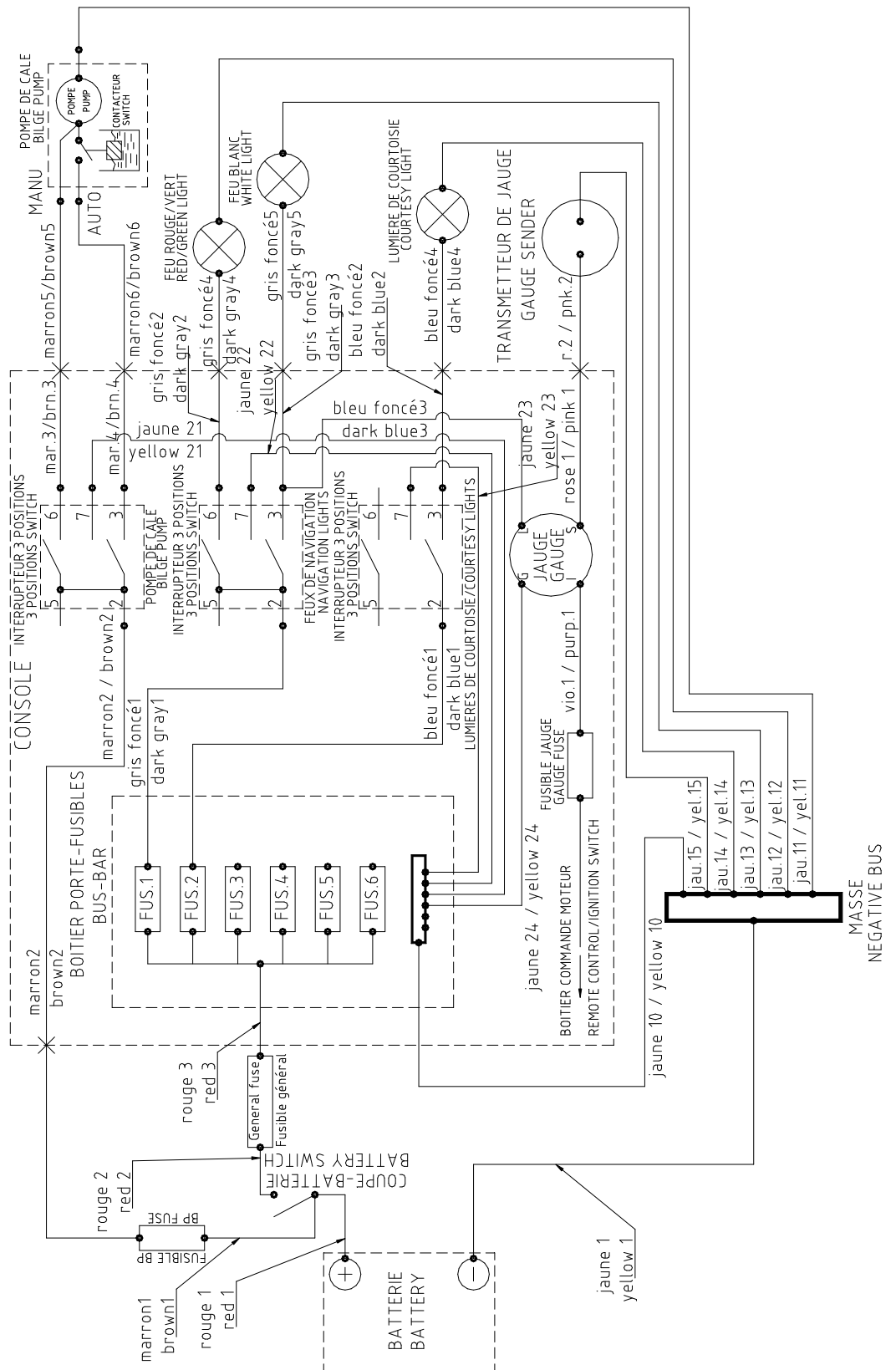



ANLAGEN UND KREISLÄUFE – Anschluss von Zusatzgeräten

IV -3-BATTERIE (nicht im Lieferumfang enthalten)

Beachten Sie bei der routinemäßigen Wartung bitte die Empfehlungen von ZODIAC und dem Batteriehersteller.

	<p>Pflegen Sie Ihre Batterie:</p> <ul style="list-style-type: none"> <input checked="" type="checkbox"/> Halten Sie die Batterie sauber und trocken, um vorzeitigen Verschleiß zu vermeiden. <input checked="" type="checkbox"/> Ziehen Sie die Anschlussklemmen fest und pflegen Sie die Batterieanschlüsse durch regelmäßiges Schmieren mit Fett.
---	--

 ACHTUNG	<p>Leitungswasser enthält Mineralien, die Ihre Batterien beschädigen. Füllen Sie die Batterie daher stets mit destilliertem Wasser auf.</p>
 WARNUNG	<ul style="list-style-type: none"> • HALTEN SIE DIE BATTERIEN UND DEN ELEKTROLYTEN VON KINDERN FERN. • Legen Sie die Batterie niemals auf die Seite. • Nehmen Sie die Batterie immer aus dem Motorraum, wenn Sie Elektrolyt nachfüllen oder die Batterie nachladen müssen. • Der Elektrolyt der Batterie ist eine giftige und gefährliche Flüssigkeit. Er enthält Schwefelsäure, die schwere Verbrennungen verursachen kann. Vermeiden Sie jeden Kontakt mit Haut, Augen und Kleidung. • Batterien können explosive Gase abgeben. Halten Sie Funkenquellen, offene Flammen, Zigaretten usw. fern. • Achten Sie darauf, dass Sie die Batterie stets an einem gut belüfteten Ort laden oder benutzen. Tragen Sie bei allen Arbeiten in der Nähe einer Batterie stets einen Augenschutz.

HINWEIS:	<ul style="list-style-type: none"> <input checked="" type="checkbox"/> Wenn Sie Ihr AVON Beiboot mindestens einen Monat lang nicht benutzen, bauen Sie die Batterie aus und lagern Sie sie an einem kühlen, dunklen und trockenen Ort. Laden Sie die Batterie vor erneuter Benutzung voll auf. <input checked="" type="checkbox"/> Wenn die Batterie für längere Zeit gelagert werden soll, prüfen Sie die Elektrolytdichte mindestens einmal monatlich und laden Sie die Batterie nach, sobald die Dichte zu stark absinkt. Elektrolytdichte: 1,28 bei 20 °C
-----------------	---

HINWEIS:	<p>Wenn Sie Ihr Boot nicht mehr benutzen, drehen Sie den Trennschalter auf die Position OFF.</p>
-----------------	--

ANLAGEN UND KREISLÄUFE – Anschluss von Zusatzgeräten

IV -4-LAGERUNG DES MASTS FÜR POSITIONSLEUCHTEN



UM beim Schließen der Sitzklappe BESCHÄDIGUNEN AM MAST für Positionsleuchten zu vermeiden, befestigen Sie den Mast STETS wie AUF NACHSTEHENDEM FOTO GEZEIGT.

HINWEIS

Mit Hilfe von aufgebrachtter Seifenlauge lässt sich der Mast leichter in den Befestigungsklammern anbringen.

ANSICHT VON OBEN:

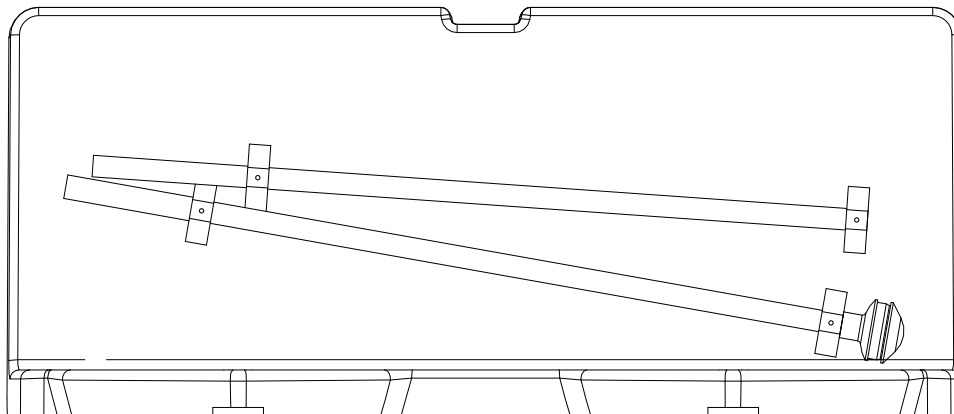

ANLAGEN UND KREISLÄUFE – Anschluss von Zusatzgeräten

IV-5-ANSCHLUSS VON ZUSATZGERÄTEN

IV-5-1-Vorsichtsmaßnahmen

Serienmäßig ist das Boot mit einer Bilgepumpe, Positionsleuchten und einer Deckbeleuchtung ausgestattet. Im Sicherungskasten (unter dem Steuerstand) sind jedoch 4 Einbauplätze für weitere Zusatzgeräte vorgesehen. Für Zusatzgeräte gelten folgende Bedingungen:

① Alle Zusatzgeräte, die Sie einbauen möchten, müssen im Steuerstand angeschlossen werden.

② Die Zusatzgeräte sind in zwei Kategorien unterteilt:

A → Zusatzgeräte, die bei normaler Benutzung des Boots dauerhaft eingesetzt werden (oder dauerhaft eingesetzt werden können),

B → Zusatzgeräte, die zeitweilig eingesetzt werden.

A		und	B	
Bilgelüfter			Zigarettenanzünderbuchse	
Radio			Diverse Beleuchtung	
Echolot			Signalhorn	
GPS-Gerät			Diverse elektronische Geräte	
Strahler			Duschpumpe	
Alarmanlage			Maßgebliche Höchstleistung	max. 72 W
Kühlschrank				
VHF-Funkgerät				
Σ	max. 180 W			

 WARNUNG	<p>Beim <u>Nachrüsten</u> ist unbedingt zu beachten, dass bei Einbau von Zusatzgeräten aus der Spalte A eine Gesamtleistung von maximal 180 W (15 A) <u>UND</u> bei Einbau von Zusatzgeräten aus der Spalte B eine Einzelleistung von maximal 72 W (6 A) nicht überschritten werden darf.</p> <p>Die Kabelquerschnitte des Kabelbaums wurden für diese Werte ausgelegt. Die Nichtbeachtung dieser Regel kann die Gefahr elektrischer Funktionsstörungen zur Folge haben und Kurzschlüsse verursachen.</p>
---	---

HINWEIS:	<p>Bei Ausstattung mit zahlreichen Elektrogeräten kann der momentane gesamte Stromverbrauch die Ladekapazität Ihres Außenbordmotors möglicherweise übersteigen. Der Kabelbaum kann beispielsweise eine momentane Leistung von 285 W aufnehmen (einschließlich Positionsleuchten und Bilgepumpe), das entspricht einer Stromstärke von rund 24 A. Bei voller Drehzahl liefern die Lichtmaschinen der heutigen Motoren in der Regel eine Stromstärke von 15 A (den genauen Wert entnehmen Sie bitte den technischen Unterlagen Ihres Motors). Eine längere Benutzung dieser Geräte sollte daher vermieden werden, da sonst die Gefahr besteht, dass sich Ihre Batterie komplett entlädt und Sie Ihren Motor nicht mehr anlassen können.</p>
-----------------	--

ANLAGEN UND KREISLÄUFE – Anschluss von Zusatzgeräten

Beispiel 1

Gewünschte Zusatzgeräte:

VHF-Funkgerät mit 72 W

GPS-Gerät mit 36 W

Radiogerät mit 60 W

Zigarettenanzünder mit 72 W

Uhr mit 20 W

A	
Bilgelüfter	
Radio	60 W
Echolot	
GPS-Gerät	36 W
Strahler	
Alarmanlage	
Kühlschrank	
VHF-Funkgerät	72 W
Σ	168 W (< 180 W) ☺

und

B	
Diverse Beleuchtung	
Diverse elektronische Geräte	20 W (Uhr)
Duschpumpe	
Maßgebliche Höchstleistung	20 W (< 72 W) ☺

ERGEBNIS



Beispiel 2

Gewünschte Zusatzgeräte:

VHF-Funkgerät mit 60 W

GPS-Gerät mit 36 W

Radiogerät mit 48 W

Strahler mit 120 W

A	
Bilgelüfter	
Radio	48 W
Echolot	
GPS-Gerät	36 W
Strahler	120 W
Alarmanlage	
Kühlschrank	
VHF-Funkgerät	60 W
Σ	264 W (> 180 W) ☹

und

B	
Diverse Beleuchtung	
Diverse elektronische Geräte	
Duschpumpe	
Maßgebliche Höchstleistung	0 (< 72 W) ☹

ERGEBNIS



ANLAGEN UND KREISLÄUFE – Anschluss von Zusatzgeräten

Beispiel 3

Gewünschte Zusatzgeräte:

GPS-Gerät mit 60 W

Radiogerät mit 60 W

Signalhorn mit 120 W

A	
Bilgelüfter	
Radio	60 W
Echolot	
GPS-Gerät	60 W
Strahler	
Alarmanlage	
Kühlschrank	
VHF-Funkgerät	
Σ	120 W (< 180 W) ↻

und

B	
Diverse Beleuchtung	
Diverse elektronische Geräte	120 W
Duschpumpe	
Maßgebliche Höchstleistung	120 W (> 72 W) ⚡

ERGEBNIS	
----------	--

HINWEIS	Einige Hersteller geben die Stromstärke statt der aufgenommenen Leistung an. Beim Gleichstrom mit einer 12-V-Batterie (das ist hier der Fall) können Sie einfach mit 12 multiplizieren, um die Leistung zu erhalten.
----------------	---

IV -5-2-Verkabelung:

- ① Wählen Sie einen freien Sicherungssteckplatz,
- ② Schließen Sie das Anschlusskabel Ihres Zusatzgeräts mit einer 6 mm breiten Flachsteckhülse an der entsprechenden Klemme für diesen Steckplatz an,
- ③ Falls Sie für den Anschluss zusätzliches Kabel benötigen, verwenden Sie ein Kabel mit einem Querschnitt von mindestens 1.5 mm², das die Empfehlungen für Bordinstallationen (UL1426 oder SAE J378 oder SAE J1127 oder SAE J1128 oder generell die ABYC und/oder CE Empfehlungen) erfüllt,
- ④ Schließen Sie das Massekabel Ihrer Zusatzeinrichtung an die Masseklemmenleiste mit einem „Ringkabelschuh“ Ø5 (Hinweis wie vorher für das Kabel),
- ⑤ Bauen Sie eine ATO-Sicherung mit einer maximalen Stromstärke von 15 A ein, wobei die Absicherung über der Stromaufnahme Ihres Geräts liegen muss.

IV -5-3-Anschluss Kraftstoffanzeige

Beachten Sie beim Anschluss die Hinweise in Schaltbild (Seite 19).

ANLAGEN UND KREISLÄUFE – Anschluss von Zusatzgeräten

IV-5-4-Einbau von Zusatzgeräten in den Steuerstand

Je nach Ausstattung Ihres Beiboots empfiehlt ZODIAC die nachstehend abgebildete Anordnung (entsprechende Bohrschablonen sind im Lieferumfang des Boots enthalten) für optimale Platznutzung.

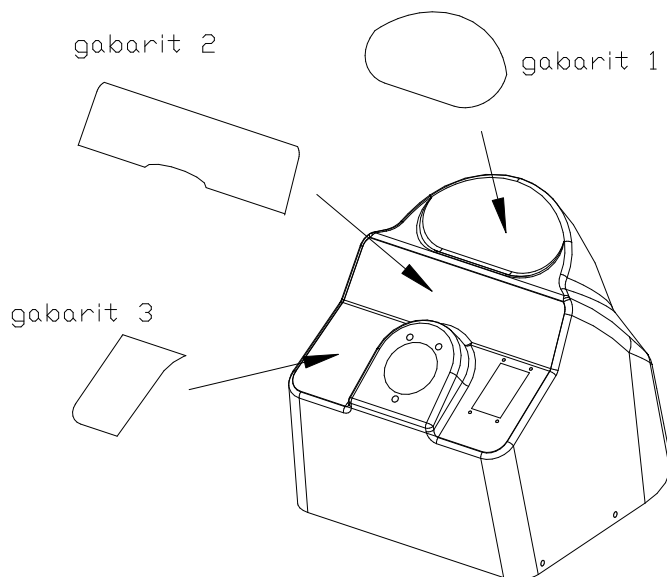

IV-6-FUNKTIONSWEISE DER BILGEPUMPE

Die Bilgepumpe kann jederzeit und unabhängig von der Stellung des Batterieschalters in Betrieb genommen werden. Der Betriebsschalter  ist stets mit Spannung versorgt.

- ① Automatikbetrieb (feste Position): In dieser Stellung funktioniert die Bilgepumpe automatisch. Die Kontrolllampe leuchtet.
- ② Stopp: In dieser Position (feste Position) ist die Bilgepumpe abgeschaltet. Die Kontrolllampe ist ausgeschaltet.
- ③ Zwangsbetrieb: Für den Zwangsbetrieb müssen Sie den Schalter gedrückt halten. Sobald Sie den Schalter loslassen, kehrt er wieder in die Position Automatikbetrieb (2) zurück.

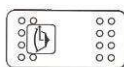

STELLEN SIE DEN SCHALTER DER BILGEPUMPE AM ANKERPLATZ AUF AUTOMATIKBETRIEB.

HINWEIS

ZODIAC empfiehlt die Benutzung einer Abdeckplane oder einer PERSENNING, um bei Regen dem Eindringen von Wasser vorzubeugen.



WARNUNG

Bitte beachten Sie, dass im Rahmen der Endfertigung manche Strukturelemente wie z. B. die Steuerkonsolen, einige Sitze und Überbauteile von anderen Unternehmen als dem Bootshersteller installiert werden. Diese Bestandteile sollten konform mit den betreffenden Anforderungen der Richtlinie ISO 6185-3 installiert werden, damit diese Einrichtungen nicht die ursprüngliche Bewertung für ungültig erklären. Vergewissern Sie sich ebenfalls, dass ein späterer Einbau von Konsolen oder anderen Strukturelementen, die nicht ursprünglich mit dem Boot geliefert wurden, entsprechend den Installationsratschlägen des Herstellers und den Empfehlungen von ZODIAC erfolgen.



ZNAUTIC GROUP

2 chemin de la Val Priout
31450 AYGUESVIVES
FRANKREICH

YACHTLINE 360 - 400



Bind 2

***YACHTLINE
360 / 400***

611133 A



LES DENNE EIERHÅNDBOKEN NØYE FØR DU TAR I BRUK OG SETTER ZODIAC I DRIFT

BIND 2



BESKRIVELSE - TUBE FREMDRIFTSSYSTEM INSTALLASJON OG KRETSER

INNHold



	SIDE
⇒ I - GENERELLE BESKRIVELSER	
I-1-Tekniske karakteristikk-----	2 - 3
I-2-Inventar-----	4 - 5
I-3-Elementenes plassering-----	6 - 7
I-4-Håndtering-----	8 - 10
⇒ II - TUBE	
II-1-Montering av idriftsetting av tuben trinn for trinn-----	11
II-2-Montasje av tuben på skroget-----	12 - 13
II-3-Oppblåsingssystem-----	14
II-4-Trykk-----	14 - 16
⇒ III - FREMDRIFTSSYSTEM	17
⇒ IV - INSTALLASJONER OG KRETSER	
IV-1-Installasjon av drivstoff-----	18 - 20
IV-2-Elektrisk diagram-----	21
IV-3-Batteri-----	22
IV-4-Oppbevaring av laternemast-----	23
IV-5-Tilkobling av tilbehør-----	24 - 26
IV-6-Drift av lensepumpe-----	27

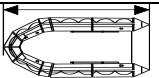

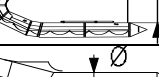
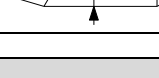
BESKRIVELSE - TEKNISKE KARAKTERISTIKKER

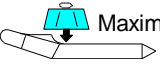
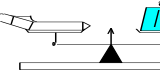

I-1-TEKNISKE KARAKTERISTIKKER

Dimensjoner			
		YL 360	YL 400
	(m)	3.60	4,00
	(fot)	11' 8"	13' 1"
	(m)	2	2,40
	(fot)	6' 7"	7' 10"
	(m)	1.77	1.77
	(fot)	5' 10"	5' 10"
	(m)	0.86	0.86
	(fot)	2' 10"	2' 10"
	(m)	0.455	0.455
	(fot)	1' 6"	1' 6"

Sertifisering	
 (direktiv 94/25/CE)	C

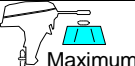
Kapasitet			
		YL 360	YL 400
 (ISO)		4	5
 Maximum	kg ⁽¹⁾	605	735
	pund (1)	1 334	1 621
	kg ⁽²⁾	200	218
	pund (2)	441	481
 Kammer		3	3

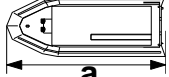
Motorisering				
		YL 360	YL 400	
	Anbefalt MIN. effekt	HK ⁽³⁾	15	20
		kW ⁽³⁾	12	15
	Anbefalt MAKS. effekt	HK	40	50
		kW	30	23
	Tillatt MAKS. effekt	HK ⁽³⁾	40	50
		kW ⁽³⁾	30	37
 Maximum	MAKS. motorvekt	kg	119	119
		pund	262	262

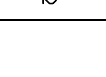
Dimensjoner			
		YL 360	YL 400
	a ⁽⁴⁾	3.18 m	3.58 m
		10' 5"	11' 9"
	b ⁽⁴⁾	1.40 m	1.40 m
		4' 6"	4' 6"
	c ⁽⁴⁾	0.98 m	0.98 m
		3' 2"	3' 2"

BESKRIVELSE - TEKNISKE KARAKTERISTIKKER

MERK	Toleranser på dimensjonene: +/- 4%
------	------------------------------------

MERK	<p>⁽¹⁾ Den maksimale tillatte lasten er beregnet i samsvar med normen ISO 6185. Når båten er lastet maksimalt, anbefales det å navigere forsiktig,</p> <p>⁽²⁾ Angitt vekt utenom tilbehør</p> <p>⁽³⁾ De anbefalte effektene svarer til optimal bruk av båtens kapasitet ved middels last (4 personer).</p> <p>⁽⁴⁾ Skrogets dimensjoner uten tube.</p> <p>Bruk den maksimale tillatte effekten med ekstrem varsomhet (se bind 1 i håndboken, kapitlet "Navigasjonsråd").</p>
------	--

 OBS	<p>Lasten som er angitt på produsentens merkeplate, må ikke overskrides. Maksimumslasten omfatter samlet vekt av motor, drivstoff, tilbehør, passasjerer og deres utstyr samt enhver type annen last.</p>
--	---

 OBS	<p>Du må ikke oppbevare antennelige produkter i akterrommet. Det er formelt forbudt å lagre en ekstra tank.</p>
--	---

BARE PÅ 400DL:

 ADVARSEL	<p>Styrbarhet begrenset ved maksimum 25 knop.</p> <p>Fare for tap av kontroll ved skarpe svinger.</p> <p>Reduser hastigheten* før du svinger uansett retning.</p> <p>* du kan også gripe inn på power trim og trekke motoren mot hekken.</p>
---	--

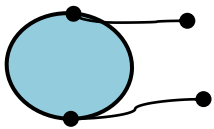
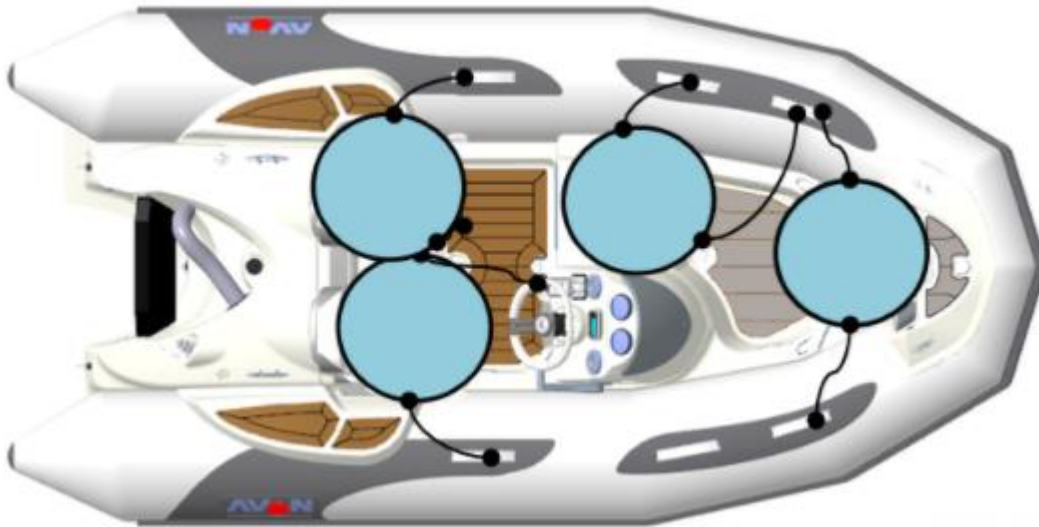

Sete med gripehåndtak til Yachtline 360

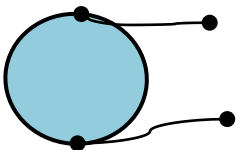
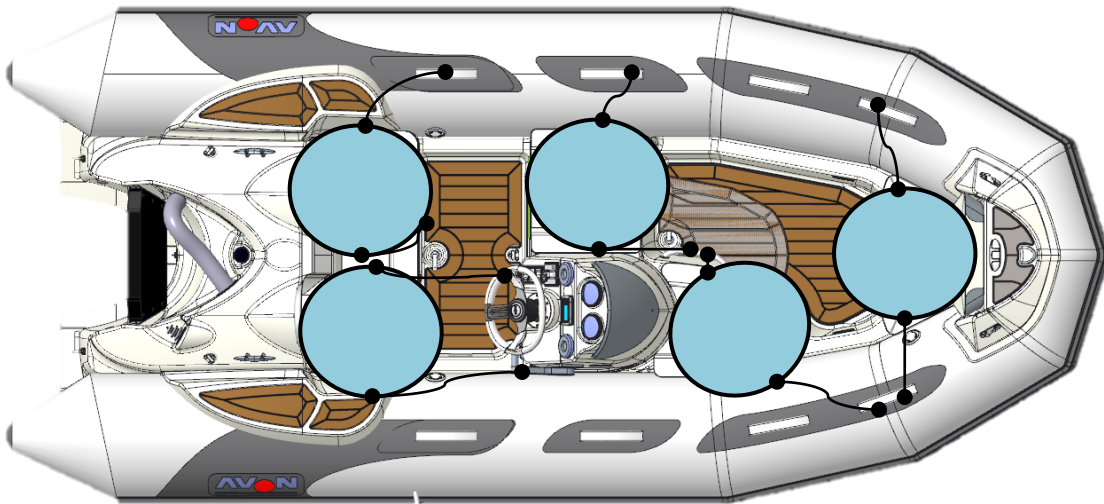

Sete med gripehåndtak til Yachtline 400

BESKRIVELSE - Inventar**I -2-INVENTAR**

SKROG
• Polyesterskrog
• formstøpt, sklisikkert dekk
• Speilhekk og kjøl med "flaps"
• Konsoll med rydderom
• 1 Fortøyningsring i forstavn
• 1 Ankringsrom + rom foran konsoll (bare på 400 YL)
• 1 akterrom
• 4 seter med polstring på YL 360 (5 seter på 400 YL)
• 2 bakre fortøyningsklamper
• 1 fremre stigbrett av polyester med fortøyningsklamp, lanterner og LEDs
• 1 inntrekkbar og avtakbar hvit lanterne-mast
• 1 dekklys
• 3 leddede røstjern for løfting
• 2 røstjern for trekking
• 2 lenseventiler + 1 skroglensepropp

TUBE
• Avtakbar tube
• Stoff av typen Hypalon-Neopren 1100 decitex
• Easy push-ventiler
• Fenderlist med bred profil
• 6 håndtak
• Kjegleforsterkninger

KONSOLL
• Ratt og ekstern styring
• 3 brytere
• Hanskerom

BESKRIVELSE - Inventar

STANDARD UTSTYR
<ul style="list-style-type: none">• 1 fast tank (35 liter + måletransmitter drivstoff + vann/bensinskiller) med åpning og anordning mot overløp
<ul style="list-style-type: none">• Navigasjonslanterner og dekklys
<ul style="list-style-type: none">• 1 batterihus
<ul style="list-style-type: none">• 1 batteribryter
<ul style="list-style-type: none">• Elektrisk forutstyr for tilføyelse av ekstra tilbehør
<ul style="list-style-type: none">• 1 lensepumpe
<ul style="list-style-type: none">• 2 padleårer
<ul style="list-style-type: none">• 1 fotpumpe
<ul style="list-style-type: none">• 1 reparasjonskoffert
<ul style="list-style-type: none">• 1 eierhåndbok (2 bind)
<ul style="list-style-type: none">• 1 propp trykkmåler

VALGFRI TTILBEHØR
<ul style="list-style-type: none">• Løftesett
<ul style="list-style-type: none">• Badestige
<ul style="list-style-type: none">• Ryggstø bak
<ul style="list-style-type: none">• Dekk av syntetisk teak
<ul style="list-style-type: none">• Vindskjerm

BESKRIVELSE – Plassering av elementene

I- 3-PLASSERING AV ELEMENTENE

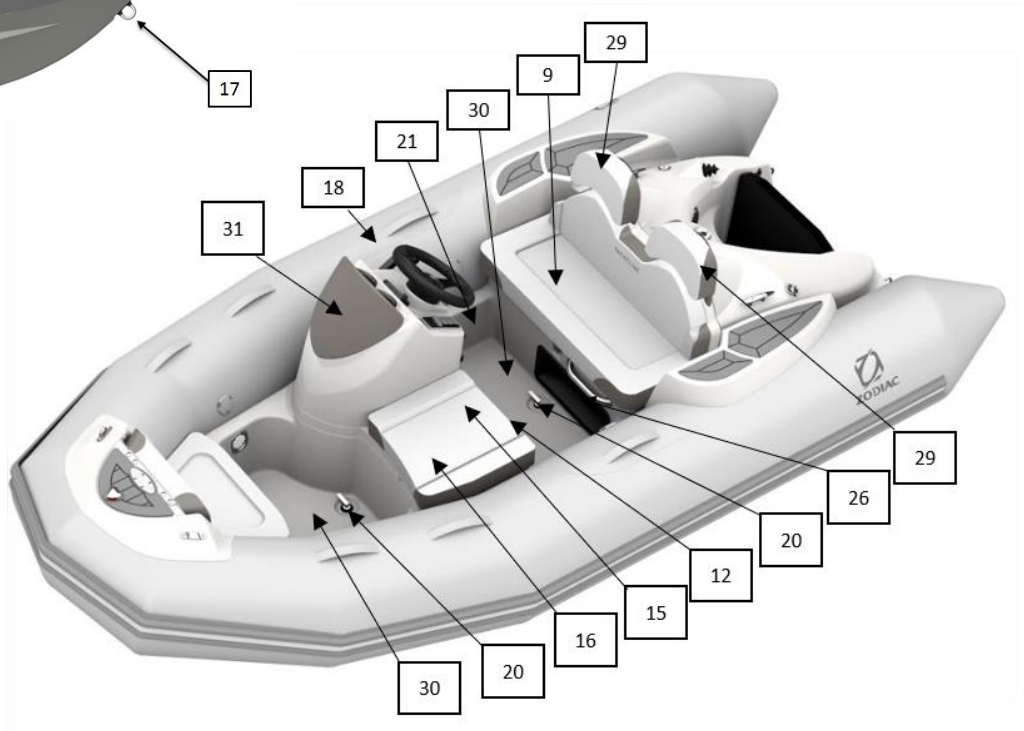
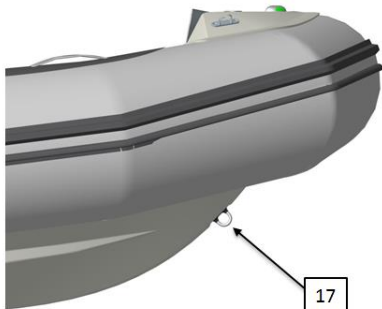
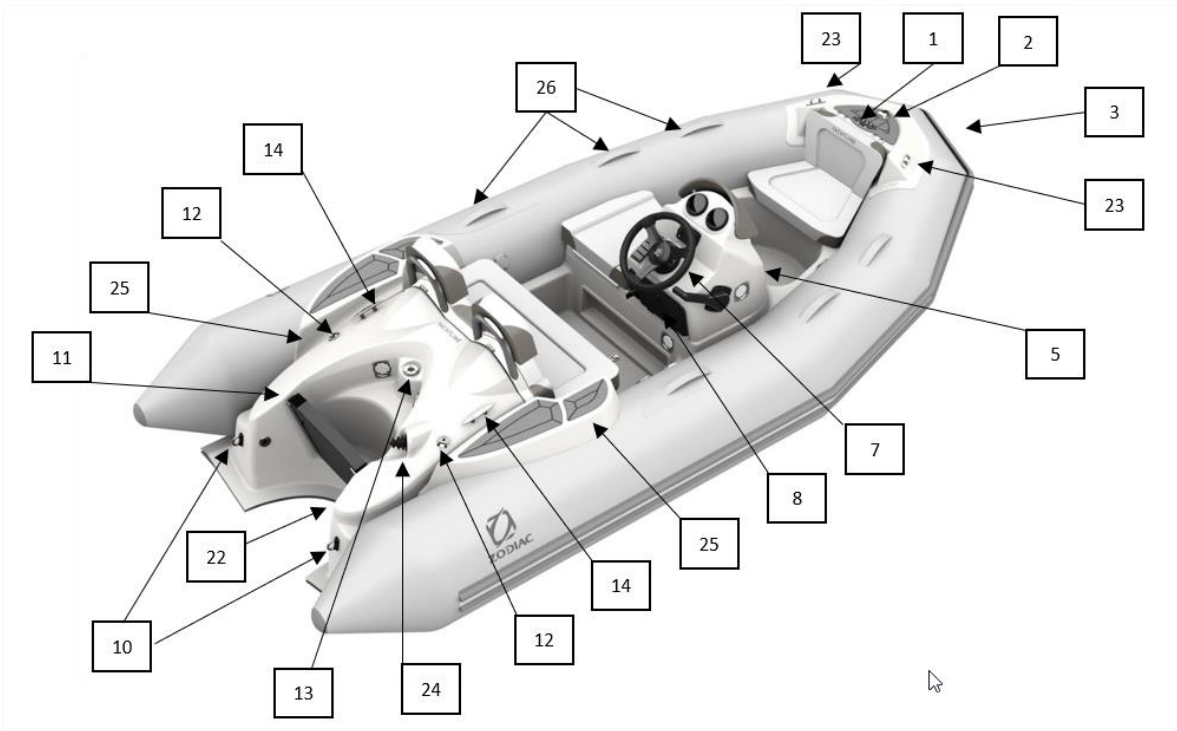

BESKRIVELSE – Plassering av elementene

MERKE	BETEGNELSE
1	Fremre fortøyningsklamp
2	Navigasjonslanterner
3	Trinn i polyester i baug
4	Ankringsrom
5	Konsoll
6	Brytere
7	Ratt
8	Hanskerom
9	Baksete som kan slås bakover
10	Trekk-/fortøyningsringer
11	Speilhekk
12	Løfteringer
13	Sokkel til mast for hvit lanterne
14	Bakre fortøyningsklamper
15	Påfyllingssystem tank
16	Adgangsluke for vedlikehold tank
17	Fortøyningsring i forstavn
18	Tube
19	Stativ brannsløkkingsapparat
20	Lenseventil
21	Dekkllys
22	Lensepropp
23	Klyss
24	Kabelmuffe
25	Trinn i polyester
26	Håndtak
27	Easy push-ventil
28	12V kontakt til sigarettenner
29	Ryggstø bak
30	Dekk av syntetisk teak
31	Vindskjerm

BESKRIVELSE - Håndtering

I-4-HÅNDTERING

I-4-1-Transport:

- Rådene for plassert på tilhenger er angitt i eierhåndbokens BIND I.

I-4-2-Lagring:

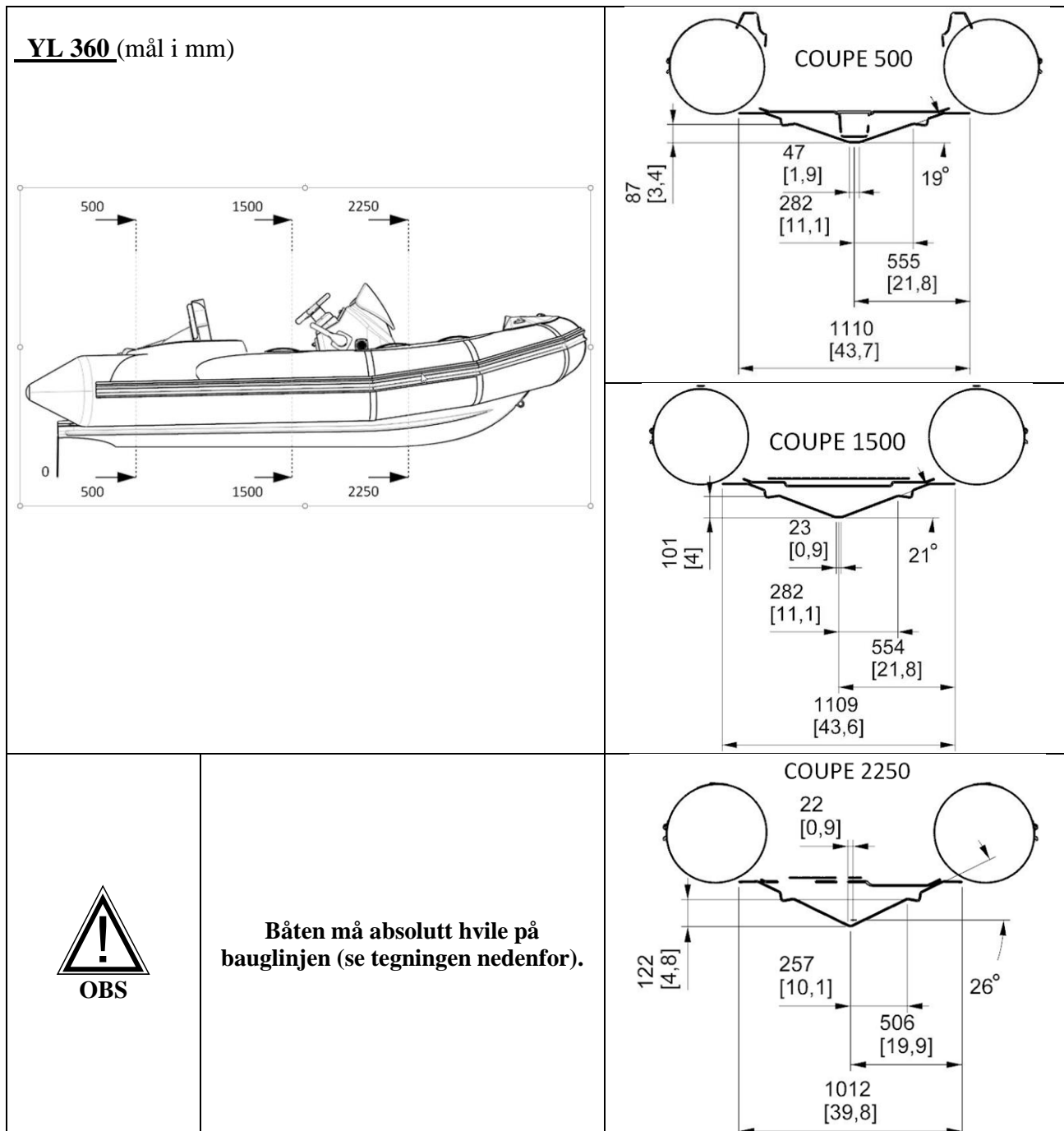

YL 400 (mål i mm)

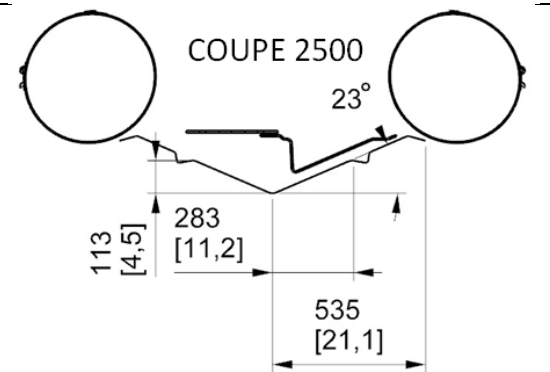
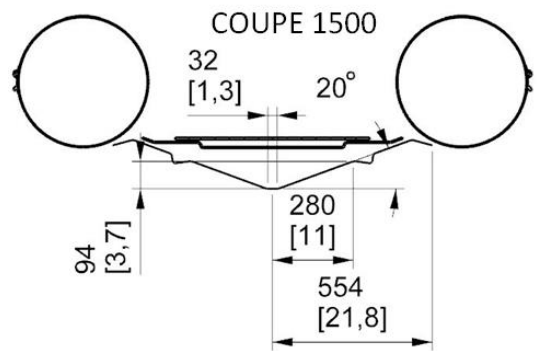
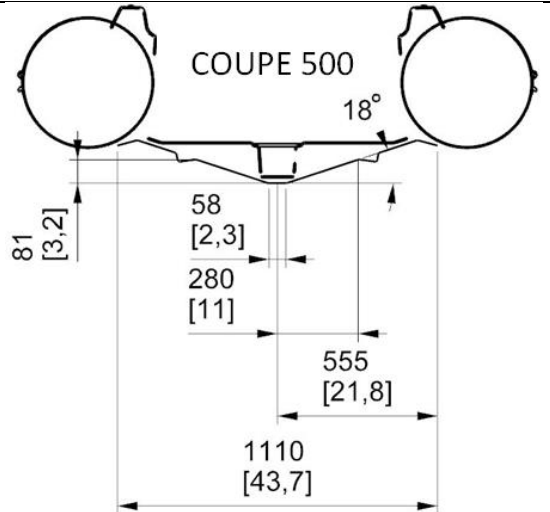
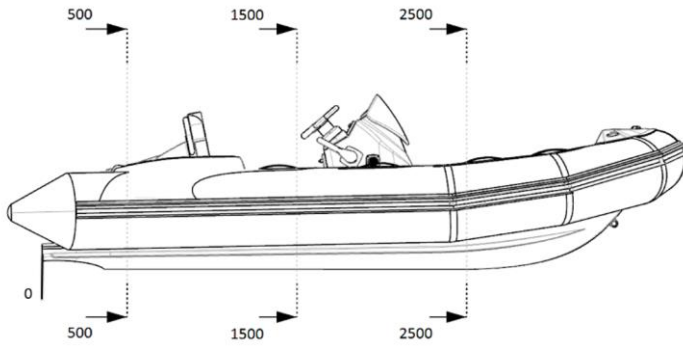

OBS

**Båten må absolutt hvile på
bauglinjen (se tegningen nedenfor).**

BESKRIVELSE - Håndtering

I -4-3-Løfting:

 ADVARSEL	<p>Løftestropp tilbys som tilbehør. Det må kun brukes Avon-stropp til løfting.</p>
--	--

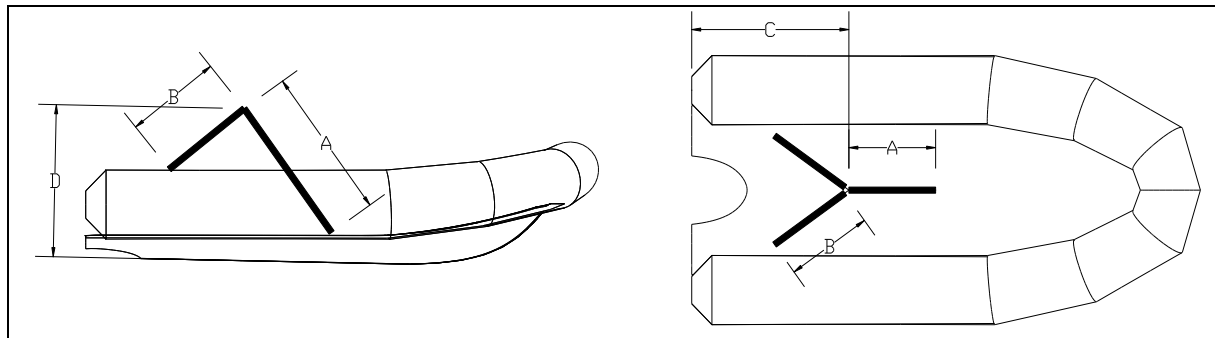

Disse verdiene er rent veiledende.		A	B	C	D
360 YL	(m)	1,25	1	1,45	1,4
	(fot)	4'1''	3'3''	4'8''	4'6''
400 YL	(m)	1,25	1	1,45	1,4
	(fot)	4'1''	3'3''	4'8''	4'6''

 ADVARSEL	<p>Ingen passasjerer ombord under løftingen.</p>
--	--

 OBS	<ul style="list-style-type: none"> Båten må være tømt for alt utstyr når den løftes eller plasseres på davit. Lenseventil for tømning av dekk (nr. 20*) og lensepropp må være åpne for å sørge for eventuell tømning av regnvann i cockpiten. <p>* Se kapittel I-3, "Plassering av elementene"</p>
---	--

TUBE – Idriftsetting

II-1-HOVEDTRINN FOR IDRIFTSETTING AV TUBEN

Prosedyren for montering av tuben følger en rekkefølge som du forplikter deg til å respektere. Gå frem trinn for trinn. Se sidene som er angitt som forklaring på fremgangsmåten.

PROSEDYRE	SIDE	AVSNITT
1. Få oversikt over delene som utgjør båten og bli fortrolig med dem	4-5	Inventar ved åpning av pakken
	6-7	Identifikasjon av plasseringen av elementene
2. Monter tuben på skroget	11	Montering av tuben
3. Fest den innvendige flap-en	12	FESTE AV FLAP-EN
4. Plasser den utvendige flap-en		
5. Aktiver ventilene i oppblåsingsposisjon	14	Oppblåsingsystem
6. Blås opp båten med driftstrykkene	15	Oppblåsing av båten
	16-17	Trykk
7. Fest den utvendige flap-en	12	FESTE AV FLAP-EN

TUBE – Idriftsetting

II-2-MONTERING AV TUBEN PÅ SKROGET

	<p>HVIS TUBEN ER LAGRET VED EN TEMPERATUR UNDER 0 °C, MÅ DU LA DEN VÆRE I 12 TIMER PÅ ET TEMPERERT STED (20 °C) FØR DU FOLDER DEN UT.</p>
---	---

<p>MERK</p>	<p>Tubens montering på skroget utføres med ikke-oppblåst tube.</p>
--------------------	---

1.

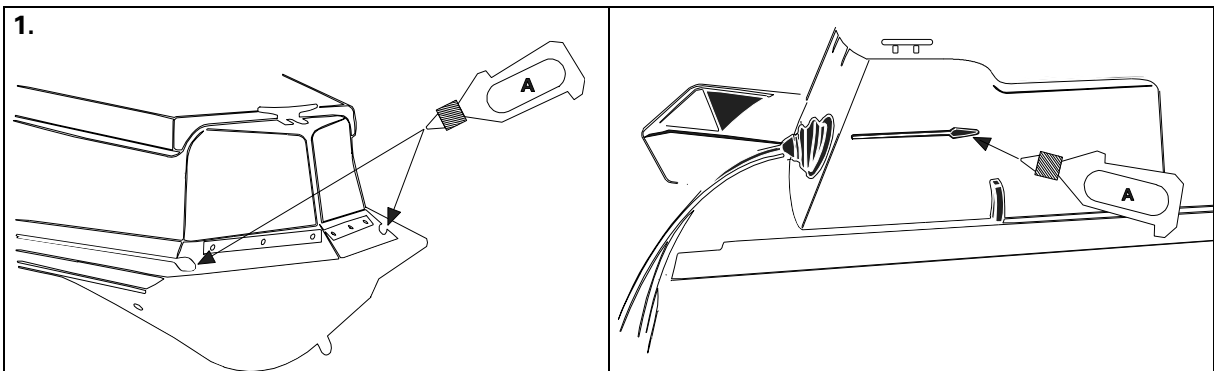

For å lette installasjon av tuben bør du bruke flytende såpe (A) i sporene på skroget.

2

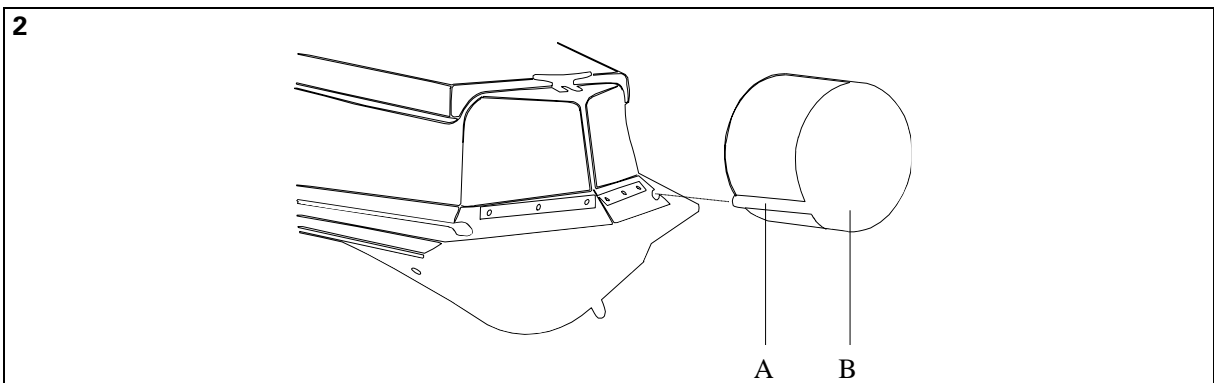

Plasser tubens (b) reling (a) i sporet på skroget.

3

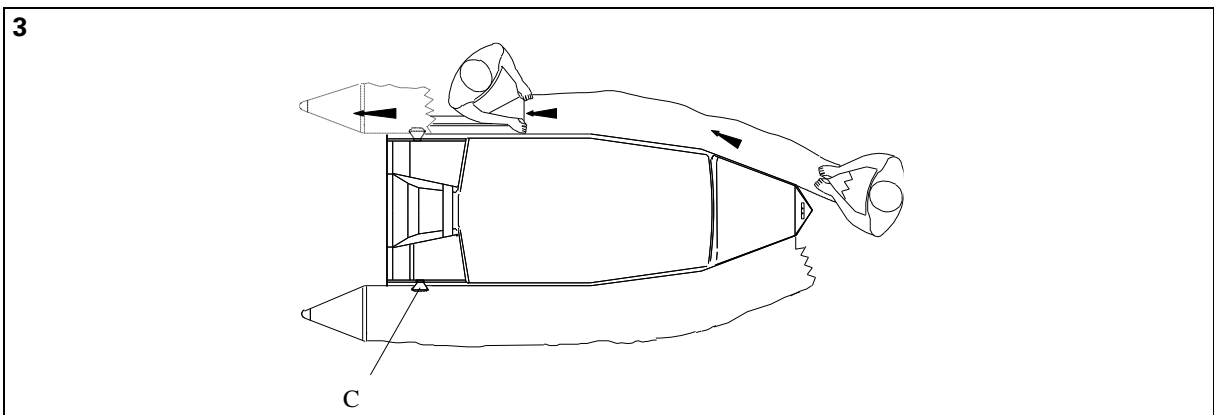

- Trekk tuben mot den bakre delen av båten (Ikke glem å styre den øvre relingen C).
- Gå frem på samme måte for den andre siden av tuben.

TUBE – Idriftsetting

4

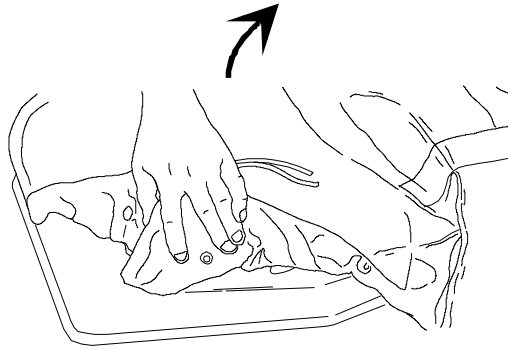

Sett på plass den innvendige flap-en

5

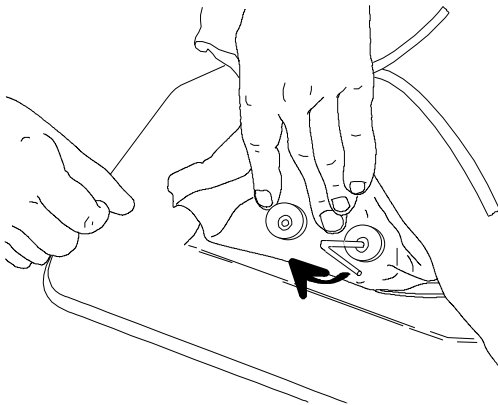

Fest den innvendige flap-en

6

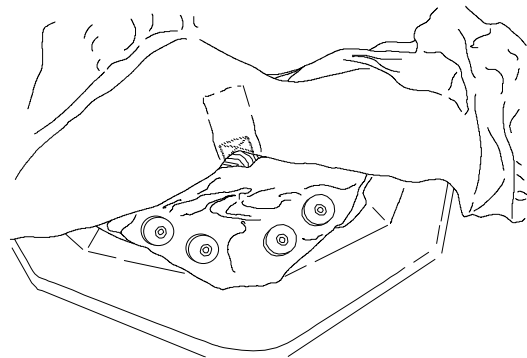

7

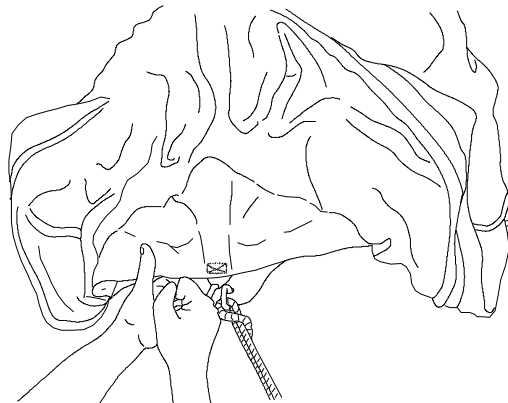

Når den innvendige flap-en er festet på skroget, trekker du tuben noe forover for å føre den utvendige flap-en over den fremre spissen (ikke fest den ennå). Trekk så tuben bakover.

MERK

Det avsluttende festet av den **utvendige** flap-en skal utføres **etter at tuben er blåst opp**

FORETA DERETTER OPPBLÅSING

TUBE - Oppblåsingsssystem

II -3-OPPBLÅSINGSSYSTEM

PUMPEN

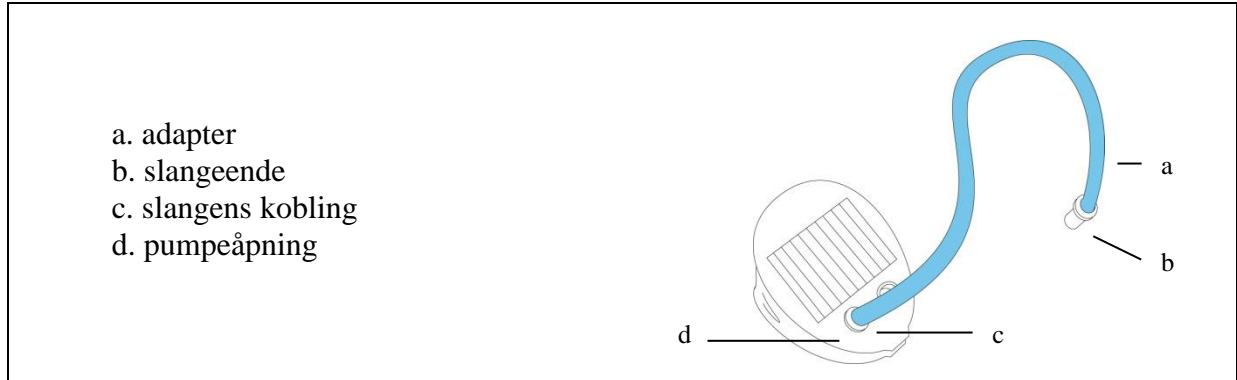

"EASY-PUSH"-VENTILER

For å endre posisjon	i oppblåsingsposisjon	i luftutslippsposisjon
<p>Trykk</p>	<p>Membranen er lukket, bryteren i øvre posisjon</p>	<p>Membranen er åpen, bryteren i nedre posisjon</p>

TUBE - Trykk

OPPBLÅSING AV MOTOREN

Aktiver alle ventiler i oppblåsingsposisjon.

Fest slangekoblingen til pumpens oppblåsingsåpning.
 For å blåse opp båten må pumpen ligge godt på bakken.
 Båten blåses opp raskt hvis pumpen brukes på en myk måte og uten hastverk.



Ikke bruk kompressor eller trykkluftflaske.

TUBE - Trykk

OPPBLÅSING AV TUBEN

- Tilføy adapteren som svarer til diameteren til ventilen som er satt inn halvveis i enden av pumpens slange.
- Blås opp tuben ved å sørge for balanse mellom de forskjellige kamrene, til veggene (a) ikke lenger er synlige (trykk = 240 mb)

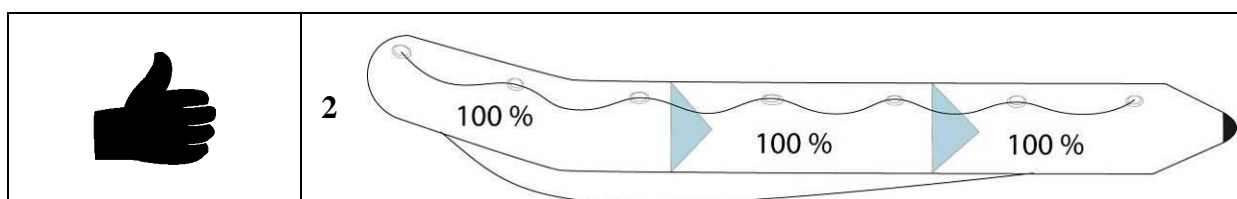
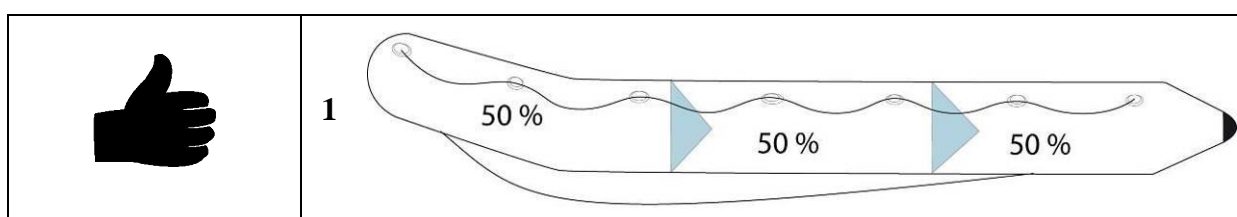
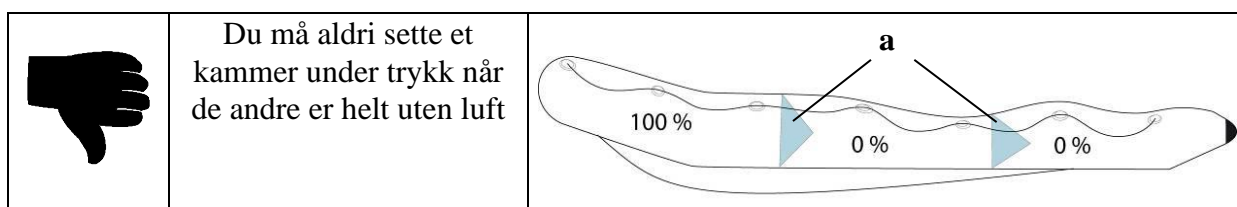

Oppblåsing er avsluttet: Skru til pumpeventilproppene.

MERK:	Det er normalt at det forekommer en lett lekkasje før ventilproppen skrues til. Bare propper gir avsluttende tetthet.
--------------	--

TUBE - Trykk

DRIFTSTRYKK

Driftstrykket i tuben er 240 mb/ 3,4 PSI.

Temperaturen i luft eller vann virker proporsjonalt inn på nivå innvendig trykk i tuben:	Omgivelsestemperatur	Innvendig trykk i tuben
	+ 1° C	+ 4 mb / + 0,06 PSI
	- 1° C	- 4 mb / - 0,06 PSI

Det er derfor viktig å foregripe:
Kontroller og juster trykket i de oppblåsbare kamrene (ved å blåse opp eller slippe ut luft alt etter hva som gjelder) ut fra temperaturvariasjonene (særlig når temperaturvariasjonene er store mellom morgen og kveld i spesielt varme regioner), og

kontroller at trykket ikke avviker fra det anbefalte området (fra 220 til 270 mb / grønt område).

RISIKO FOR UNDERTRYKK:

Eksempel: Båten ligger i sterk sol på strand (temperatur = 50°C) og har anbefalt trykk (240 mb/3,4 PSI). Når du setter den på vann (temperatur = 20°C), vil temperaturen og det innvendige trykket i de oppblåsbare kamrene synke samtidig (ned til 120 mb), og du må da **BLÅSE OPP IGJEN** helt til du har fått dekket millibarene som ble tapt grunnet temperaturforskjellen mellom luften og vannet. Det er også normalt at det forekommer en trykksenkning på slutten av dagen når utendørstemperaturen synker.

FARE FOR OVERTRYKK:

Eksempel: Båten er oppblåst til anbefalt trykk (240 mb / 3,4 PSI) ved dagens begynnelse eller slutt (utendørs temperatur = 10°C). Senere på dagen ligger båten på stranden i sterk sol eller på dekket til en yacht (temperatur = 50°C). Den innvendige temperaturen til de oppblåsbare kamrene kan da stige opptil 70 °C (særlig hvis tubene er mørkfarget), noe som medfører at startrykket dobles (480 mb). Du må da **SLIPPE UT LUFT** for å gå tilbake til anbefalt trykk.



OBS

Hvis båten er for sterkt oppblåst, belaster trykket den oppblåsbare strukturen unormalt mye og dette kan medføre brudd på enheten.

TUBE - Trykk

VED OVERTRYKK

EASY PUSH-ventil:
Frigjør luft ved å trykke på ventilbryteren.

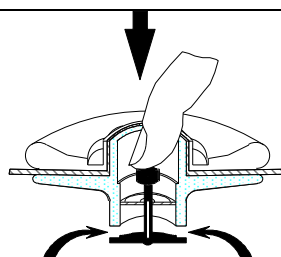

FREMDRIFTSSYSTEM

III - Fremdriftssystem

Følg anbefalingene fra ZODIAC og motorprodusenten.

For optimal bruk av båten bør du kontakte forhandler.

INSTALLASJON OG KRETS - Drivstoff

IV -1-Installasjon av drivstoffsystem

IV -1-1-Tank

Tanken befinner seg under styrekonsollen:

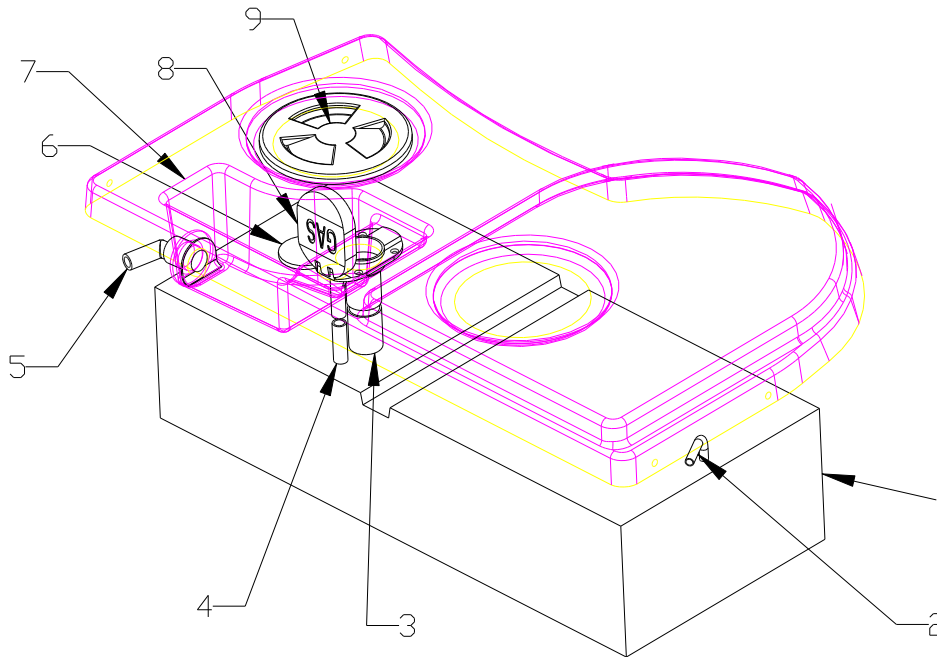

MERKE	BETEGNELSE
1	Tank
2	Utgang for motortilførsel
3	Påfyllingsåpning
4	Ventilasjonsåpning
5	Tømmepropp for "overflyt"-kammeret
6	Måletransmitter
7	"Overflyt"-kammer
8	Påfyllingspropp med innebygd ventilasjonsåpning
9	Vedlikeholdsluke tank

 OBS	<p>Det er obligatorisk med måleskive for bensinmåler. Denne leveres med motoren. Dersom du ikke har denne må du ta kontakt med agenten din.</p>
---	---

Sonden er av standard amerikansk type, dvs.:

Impedans (posisjon tom tank) 30 ohm

Impedans (posisjon full tank) 240 ohm

Bortsett fra enkelte noen sjeldne unntak er alle måleskivene kompatible.

Angående tilkobling, se de elektriske diagrammet side 22.

INSTALLASJON OG KRETS – Tank og tilbehør

IV-1-2- Filter for skille vann/bensin

MERK:	For å beskytte motoren er et vann/bensinskillefilter plassert på motorens bensintilførselskrets.
--------------	--

Filteret for skille vann/bensin finnes i akterrommet, på styrbordveggen:

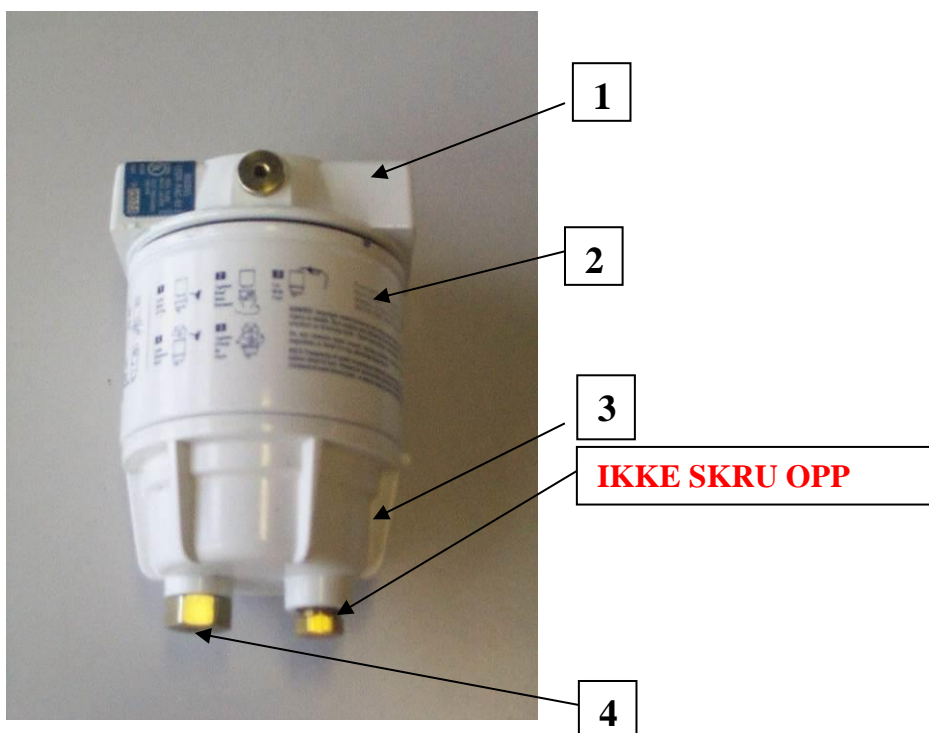

MERKE	BETEGNELSE
1	Filterhode, festet til båten
2	Utskiftbart filtreringselement
3	Metallskål
4	Tømmeskrue

 ADVARSEL	Ikke skru opp den lille skruen: du vil komme til å skade pakningen og forringer bollens tetthet.
--------------	--

MERK	Ved hver bruk må du sjekke at det ikke er vann i metallskålen: Skru noe løs tømmeproppen (ikke fjern den helt); tøm vannet; skru til proppen igjen hvis det bare er bensin i skålen. Gjenta operasjonen oftere hvis motoren ikke fungerer riktig.
-------------	---

INSTALLASJON OG KRETS – Tank og tilbehør

 ADVARSEL	<p>Det er helt nødvendig å tømme og rengjøre filteret regelmessig, og skifte patron minst en gang i året. Metallboken kan gjenbrukes.</p>
--	--

Utskiftning av filteret:

Følg anbefalingene fra ZODIAC og filterprodusenten.

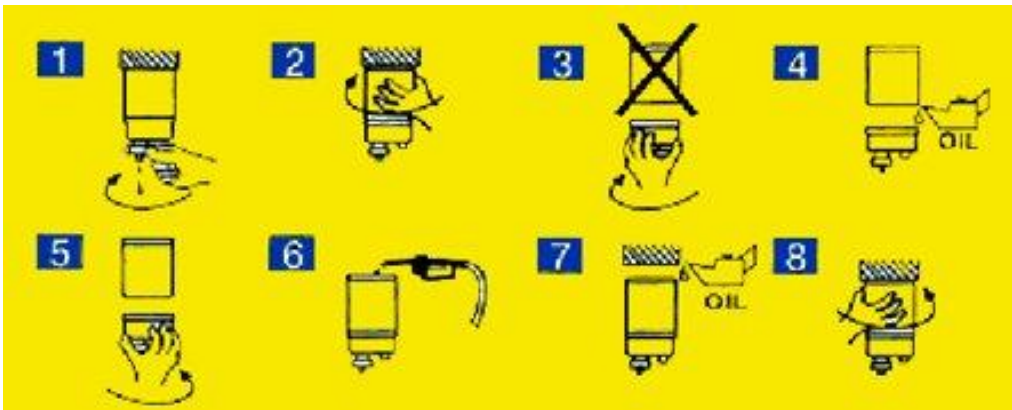

IV-1-3-Anbefalinger:

 ADVARSEL	<ul style="list-style-type: none"> <input checked="" type="checkbox"/> Full tank gjør det mulig å unngå kondensasjon ved hver utfart. <input checked="" type="checkbox"/> Få tanken rengjort hvert 5. år. <input checked="" type="checkbox"/> Kontroller at klemmene er trukket til på alle slangene. <input checked="" type="checkbox"/> Når du tømmer filteret, unngå å tømme vannet i båten. Bruk oppsamlingskaret under filteret. <input checked="" type="checkbox"/> Slå av tenningen før du fjerner filterpatronen. <input checked="" type="checkbox"/> Les nøye instruksjonene i filtrets veiledning.
--	--

 ADVARSEL	<ul style="list-style-type: none"> <input checked="" type="checkbox"/> Bensin er ekstremt antennelig. Pass på at motorene er stanset når du skal gripe inn på drivstoffsystemet. Du må ikke røyke. Fjern alle flammer eller glødende legemer bort fra arbeidssonen.
--	---

INSTALLASJON OG KRETS - Elektrisitet

IV -2-ELEKTRISK SKJEMA

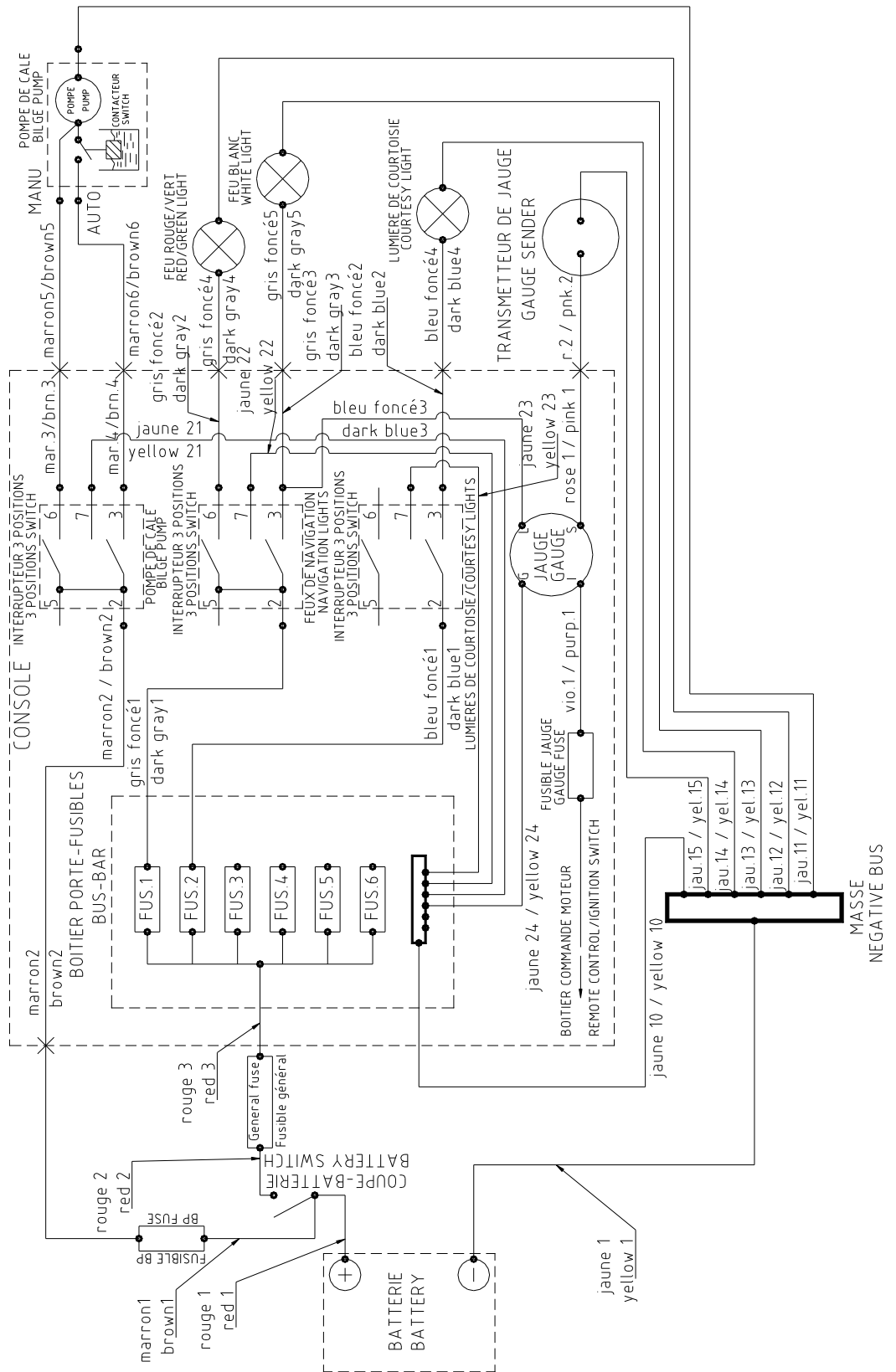



INSTALLASJON OG KRETS - TILKOBLING AV EKSTRAUTSTYR

IV -3-BATTERI (følger ikke med)

Følg anbefalingene fra Zodiac og batteriprodusenten når det gjelder vanlig vedlikehold.

	<p>Hold batteriet vedlike:</p> <ul style="list-style-type: none"> <input checked="" type="checkbox"/> Hold batteriet rent og tørt for å unngå tidlig slitasje. <input checked="" type="checkbox"/> Trekk til og hold vedlike batteriklemmene på terminal ved å smøre regelmessig med fett.
---	---

 OBS	<p>Vannet fra vanntilførselssystemet inneholder mineraler som skader batteriene. Du må derfor alltid fylle på med destillert vann.</p>
 ADVARSEL	<ul style="list-style-type: none"> • Hold batteriene og elektrolytten utilgjengelig for barn • Legg aldri batteriet ned. • Når du tilføyer elektrolytt eller lader batteriet, må du alltid fjerne det fra motorhuset. • Batterielektrolytten er en giftig, farlig væske. Den inneholder svovelsyre som kan medføre alvorlige brannsåre. Unngå all kontakt med huden, øynene og klærne. • Batteriene kan avgi eksplosive gasser. Hold gnistkilder, åpne flammer, sigaretter osv. unna. • Når du lader eller bruker et batteri, må dette skje på et godt luftet sted. Beskytt alltid øynene når du arbeider i nærheten av et batteri.

MERK:	<ul style="list-style-type: none"> <input checked="" type="checkbox"/> Når Zodiac-jollen ikke skal brukes i en måned eller to, må du ta ut batteriet og lagre det på et kjølig, mørkt og tørt sted. Lad batteriet helt opp før du bruker det på nytt. <input checked="" type="checkbox"/> Hvis batteriet har vært satt på lagring i lengre tid, må du kontrollere elektrolyttens tetthet minst én gang i måneden og lade batteriet opp igjen når tettheten er for lav. <p>Elektrolyttens tetthet: 1,28 ved 20 °C</p>
--------------	--

MERK:	<p>Når du ikke lenger bruker båten, må du sette nødstoppen på OFF.</p>
--------------	--

INSTALLASJON OG KRETS - TILKOBLING AV EKSTRAUTSTYR

IV -4-LAGRING AV LANTERNEMASTEN



For å ikke skade lanternemasten når setet lukkes, sørg for å feste den som angitt på bildet.

MERK

For å gjøre det lettere å feste masten i festepunktene, er det mulig å føre på såpevann.

SETT OVENFRA:

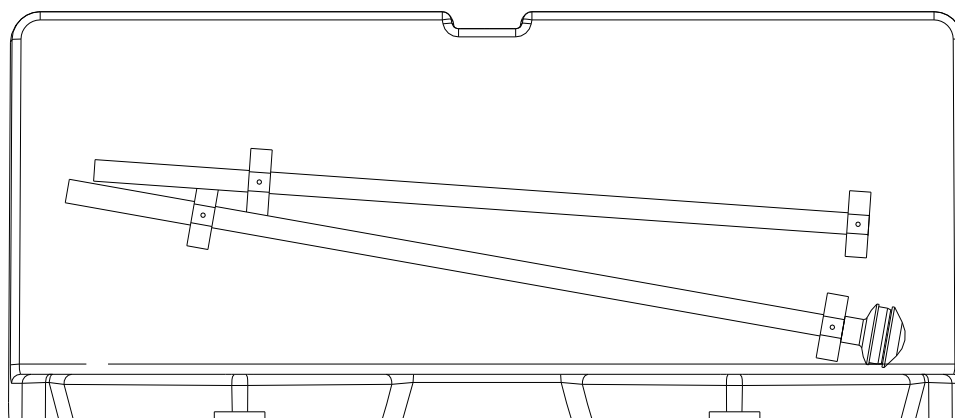

INSTALLASJON OG KRETS - TILKOBLING AV EKSTRAUTSTYR

IV -5-TILKOBLING AV EKSTRAUTSTYR

IV -5-1-Forholdsregler:

Båten er som standard utstyrt med en lensepumpe, og som ekstrautstyr med navigasjonslanterner og et dekklys. Men 4 kamre forblir tilgjengelige på sikringsboksen (under konsollen) for tilkobling av ekstra tilbehør, på visse betingelser:

- ① Tilbehør du tilføyer må kobles til ved konsollen.
- ② Tilbehøret inngår i to kategorier:
 - A → tilbehør som brukes eller kan brukes kontinuerlig ved normal bruk av båten,
 - B → tilbehør som brukes med mellomrom.

A	og	B	
Bunnventilator		Uttak sigarettener	
Radio		Diverse belysning	
Lodd		Horn	
GPS		Diverse elektronisk utstyr	
Lyskaster		Dusjpumpe	
Alarmsystem		Maksimal påkrevd effekt	72 W maks.
Kjøleskap			
VHF			
Σ			180 W maks.

 ADVARSEL	<p>Du må absolutt kontrollere at totaleffekten for tilbehørene i kolonne A som du <u>tilføyer</u>, er under eller lik 180 W (15 A) og at den maksimale effekten til et tilbehør i kolonne B er under eller lik 72 W (6 A).</p> <p>Diameterne til de forskjellige ledningene i ledningsnett er beregnet med disse verdiene. Manglende overholdelse av denne regelen kan medføre elektriske feil og kortslutninger.</p>
--	--

MERK:	<p>Hvis du installerer mange elektriske enheter, kan det totale forbruket eventuelt overstige ladekapasiteten til påhengsmotoren. For eksempel kan det elektriske ledningsnett tåle et øyeblikkelig forbruk på 285 W (medregnet lanterner og lensepumpe), dvs. litt mindre enn 24 A i strømforbruk. De nåværende dynamoene til motorene gir som regel en intensitet på 15 A ved full motorhastighet (Bør sjekkes i det tekniske dokumentet til motoren). Du må derfor unngå forlenget bruk av disse apparatene, ellers risikerer du å tømme batteriet slik at motoren ikke starter.</p>
--------------	---

INSTALLASJON OG KRETS - TILKOBLING AV EKSTRAUTSTYR

Eksempel 1

Du vil tilføye:

En VHF på 72 W,

En GPS på 36 W,

En radio på 60 W,

En sigarettenner på 72 W,

En klokke på 20 W.

A	
Bunnventilator	
Radio	60 W
Lodd	
GPS	36 W
Lyskaster	
Alarmsystem	
Kjøleskap	
VHF	72 W
Σ	168 W (<180 W) ☺

og

B	
Diverse belysning	
Diverse elektronisk utstyr	20 W (klokke)
Dusjpumpe	
Maksimal påkrevd effekt	20 W (< 72 W) ☺

KONKLUSJON



Eksempel 2

Du vil tilføye:

En VHF på 60 W,

En GPS på 36 W,

En radio på 48 W,

En lyskaster på 120 W.

A	
Bunnventilator	
Radio	48 W
Lodd	
GPS	36 W
Lyskaster	120 W
Alarmsystem	
Kjøleskap	
VHF	60 W
Σ	264 W (> 180 W) ☹

og

B	
Diverse belysning	
Diverse elektronisk utstyr	
Dusjpumpe	
Maksimal påkrevd effekt	0 (< 72 W) ☺

KONKLUSJON



INSTALLASJON OG KRETS - TILKOBLING AV EKSTRAUTSTYR

Eksempel 3

Du vil tilføye:

En GPS på 60 W,

En radio på 60 W,

Et horn på 120 W.

A	
Bunnventilator	
Radio	60 W
Lodd	
GPS	60 W
Lyskaster	
Alarmsystem	
Kjøleskap	
VHF	
Σ	120 W (< 180 W) ☺

og

B	
Diverse belysning	
Diverse elektronisk utstyr	120 W
Dusjpumpe	
Maksimal påkrevd effekt	120 W (> 72 W) ☹

KONKLUSJON	
------------	--

MERK	Visse produsenter angir spenning i stedet for absorbert effekt. I likestrøm med et batteri på 12 V (som i dette tilfellet), holder det å gange med 12 for å oppnå effekten.
-------------	--

IV -5-2-Forholdsregler:

- ① Velg en ledig sikringsplass,
- ② Koble tilbehørets tilførselsledning til terminalen som svarer til denne plasseringen med en "tungeklemme" (hunkobling) på 6mm.
- ③ Hvis du skal legge til en ledning for tilkoblingen, skal den ha en minimal diameter på 1,5 mm². Respekter anbefalingene for ledninger til sjøs (UL1426, SAE J378, SAE J1127 eller SAE J1128 eller, generelt, samsvar med ABYC- og/eller EU-anbefalingene).
- ④ Koble tilbehørets jordingsledning til terminalblokken for jording med en "øyeklemme" Ø5 (samme merknad som før for tilførselsledningen).
- ⑤ Sett inn en sikring av type ATO med maksimal strømstyrke på 15A og over apparatets strømstyrke ved bruk.

IV -5-3-Tilkobling bensinmåler:

Koble til i henhold til angivelsene på diagrammet (side 19).

INSTALLASJON OG KRETS - TILKOBLING AV EKSTRAUTSTYR

IV -5-4-Installasjon av tilbehør på konsollen:

Ut fra jollens utstyrsnivå, anbefaler ZODIAC følgende opplegg (se borelærene som fulgte med båten) for å optimalisere tilgjengelig plass.

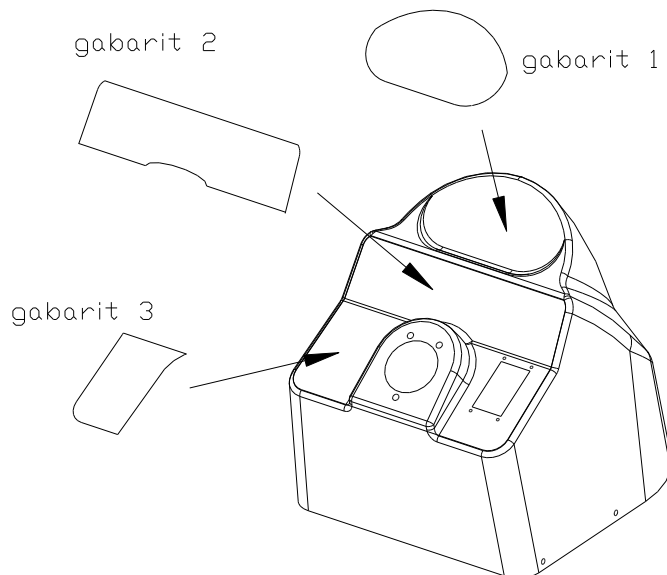

IV -6-FUNKSJONSMÅTE TIL LENSEPUMPEN

Lensepumpen fungerer uavhengig av batteribryterens posisjon; kommandobryteren  er alltid på.

- ①Automatisk modus (fast posisjon): I denne posisjonen fungerer lensepumpen automatisk. Lampen er tent.
- ②Stans: I denne posisjonen (fast posisjon) er lensepumpen stanset. Lampen er slukket.
- ③Forsert modus: Bryteren må holdes nede for å oppnå drift i forsert modus. Når du slipper fingeren, går bryteren tilbake i stopp-posisjon (2).



 ADVARSEL	Ved forankring må du sette lensepumpebryteren på automatisk drift.
--	--

MERK	Zodiac anbefaler bruk av presenning for å unngå regnvann i båten når den er fortoydd.
-------------	---

**ADVARSEL**

Det gjøres oppmerksom på at i avslutningsprosessen blir de strukturelle elementene, som for eksempel styrekonsoll, seter og superstrukturer, installert av andre parter enn båtprodusenten. Disse elementene bør installeres på en slik måte at de er i overensstemmelse med de gjeldende kravene i ISO 6185-3 for å garantere at alle disse installasjonene ikke vil ugyldiggjøre den opprinnelige evalueringen.

Forsikre deg også om at senere installasjon av konsoller og andre strukturelle elementer som opprinnelig ikke ble levert med båten, må utføres i samsvar med installasjonsrådene fra konstruktøren og anbefalingene fra ZODIAC.



ZNAUTIC GROUP

2 chemin de la Val Priout
31450 AYGUESVIVES
FRANKRIKE

YACHTLINE 360 - 400