

ROLL-UP 200AL

SPECIFICATIONS

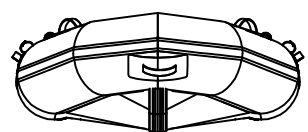
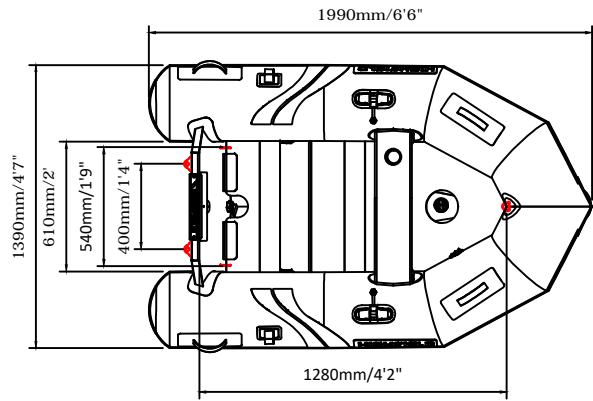
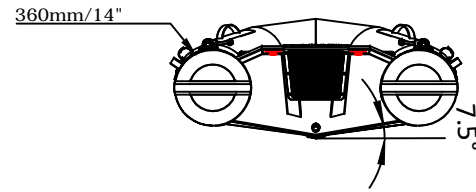
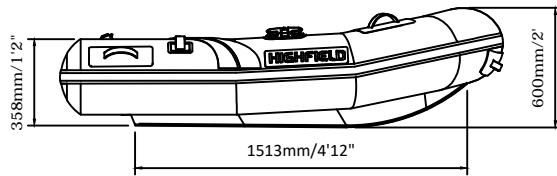

SPECIFICATIONS AND MAXIMUM CAPACITIES (Subject to change without notice.Tolerances:Dimensions ±2.5% Weight ±5%)

MODEL	ISO 6185 PART	ISO 6185	Passengers		Weight		Outboard Engine	Shaft	Max power				Max weight				Fuel tank Capacity		Wet Weight (Approximate)		AIR CHAMBERS	Pressure					
			KG	LB	#	KG			LB	KW		HP		KG		LB		L	GAL	KG		LB	PSI	BAR			
RU200AL	1	C	160	353	2	150	331	S	2.61	3.5	18	40	28	62	/	/	/	/	/	/	/	/	46	101	3	3.63	0.25

Boat weight includes: boat only