

SPORT 900 EPA

SPECIFICATIONS

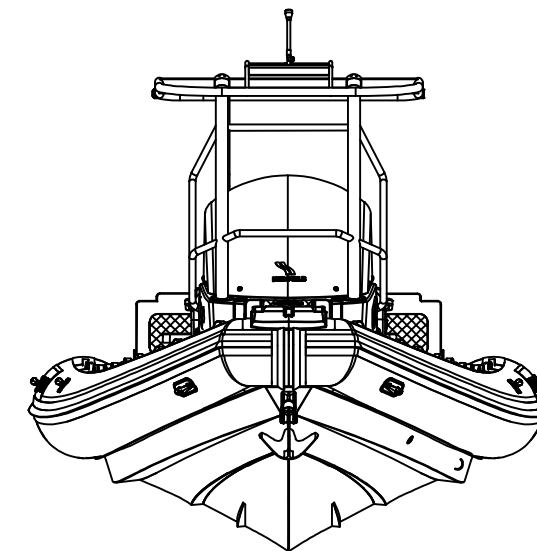
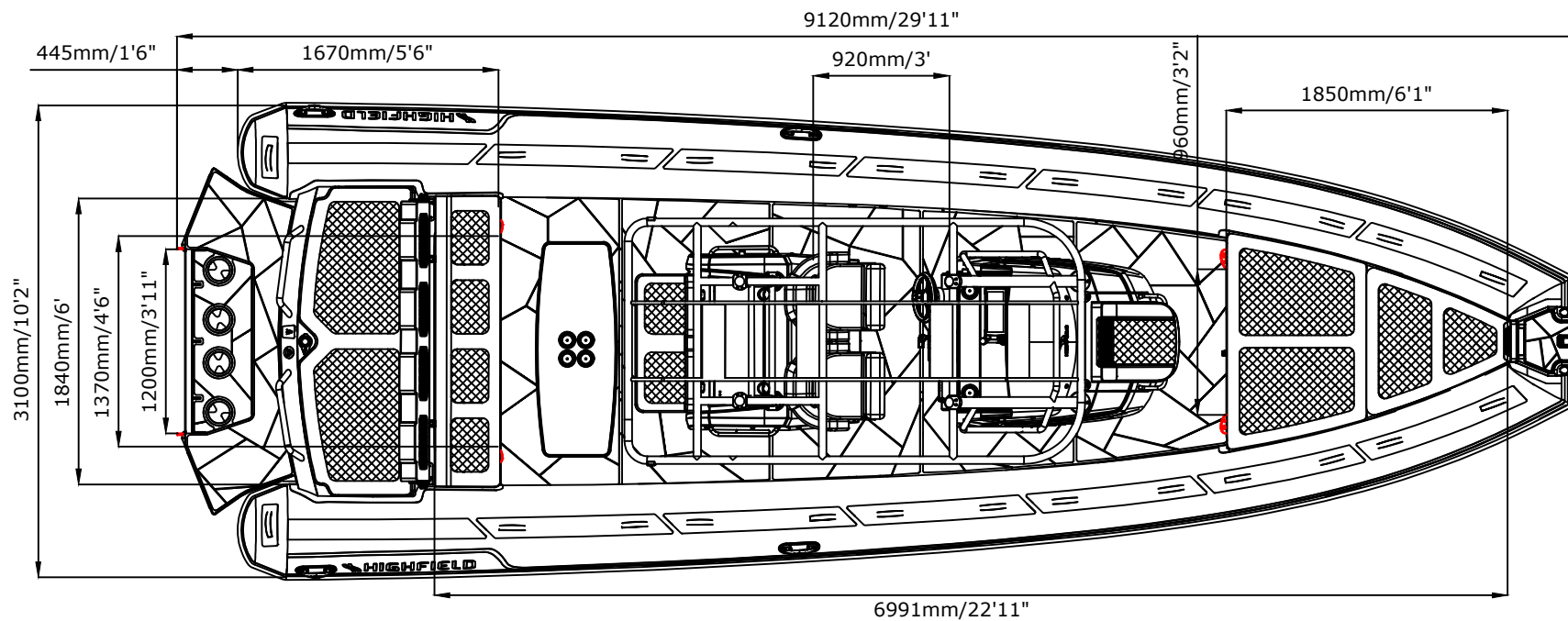
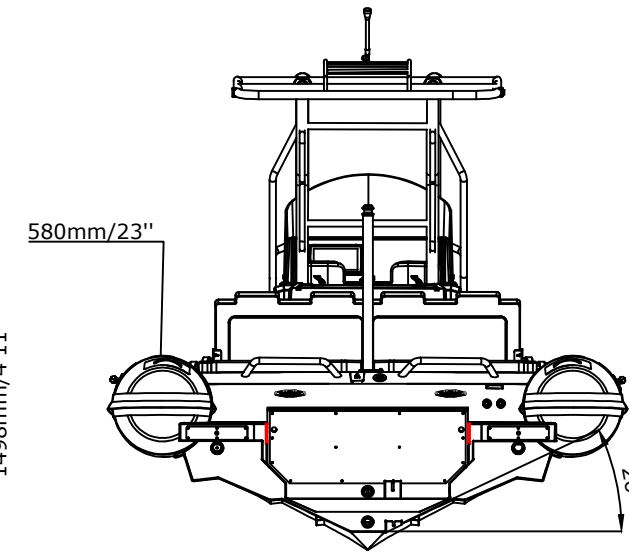
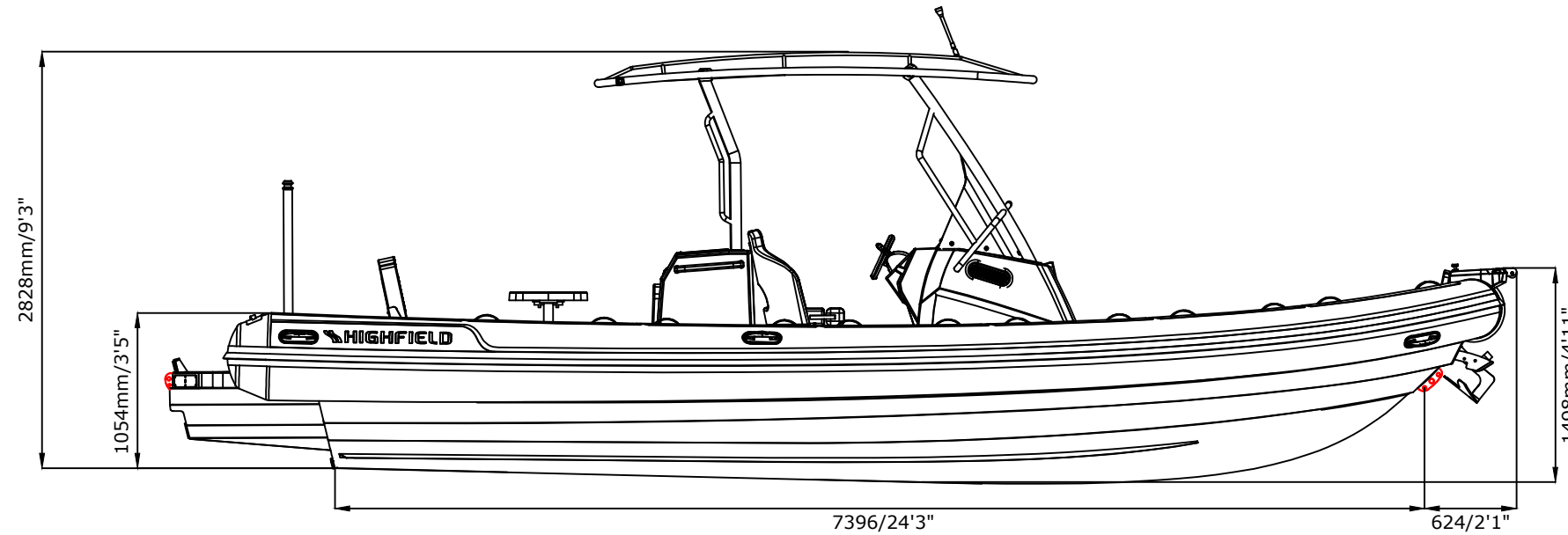

SPECIFICATIONS AND MAXIMUM CAPACITIES (Subject to change without notice. Tolerances: Dimensions ±2.5% Weight ±5%)

MODEL	ISO 6185 PART	ISO 6185			#			Shaft	Outboard Engine		Shower kit		Rollbar		Tow post		Fuel tank Capacity		Wet Weight (Approximate) 2*300HP (2*223.8KW) +Fuel		AIR CHAMBERS						
			KG	LB		KG	LB		KG	LB	KG	LB	KG	LB	KG	LB	L	GAL	KG	LB		PSI	BAR				
SP900	4	C	2405	5302	19	1425	3142	XL	2*223.8	2*300	600	1323	1780	3924	14.4	31.7	/	/	10.7	23.6	352	93	2655.5	5854	6	3.63	0.25

Boat weight includes: console ,seat

2023V2